

8		7		6		5		4		3		2		1	
DWG NO	MODEL	DETAIL DC OR DD	DETAIL BB OR BC	DETAIL CB OR CC	DETAIL CE OR CF	DETAIL CG OR CH									
186159-01	327Q	DC	BB	CB	CE	CG									
186159-02	327QP	DD	BC	CC	CF	CH									

RELEASE	REV DATE	DWG NO	186159
REV ZONE	REVISION RECORD	DATE	DFT-ORIG

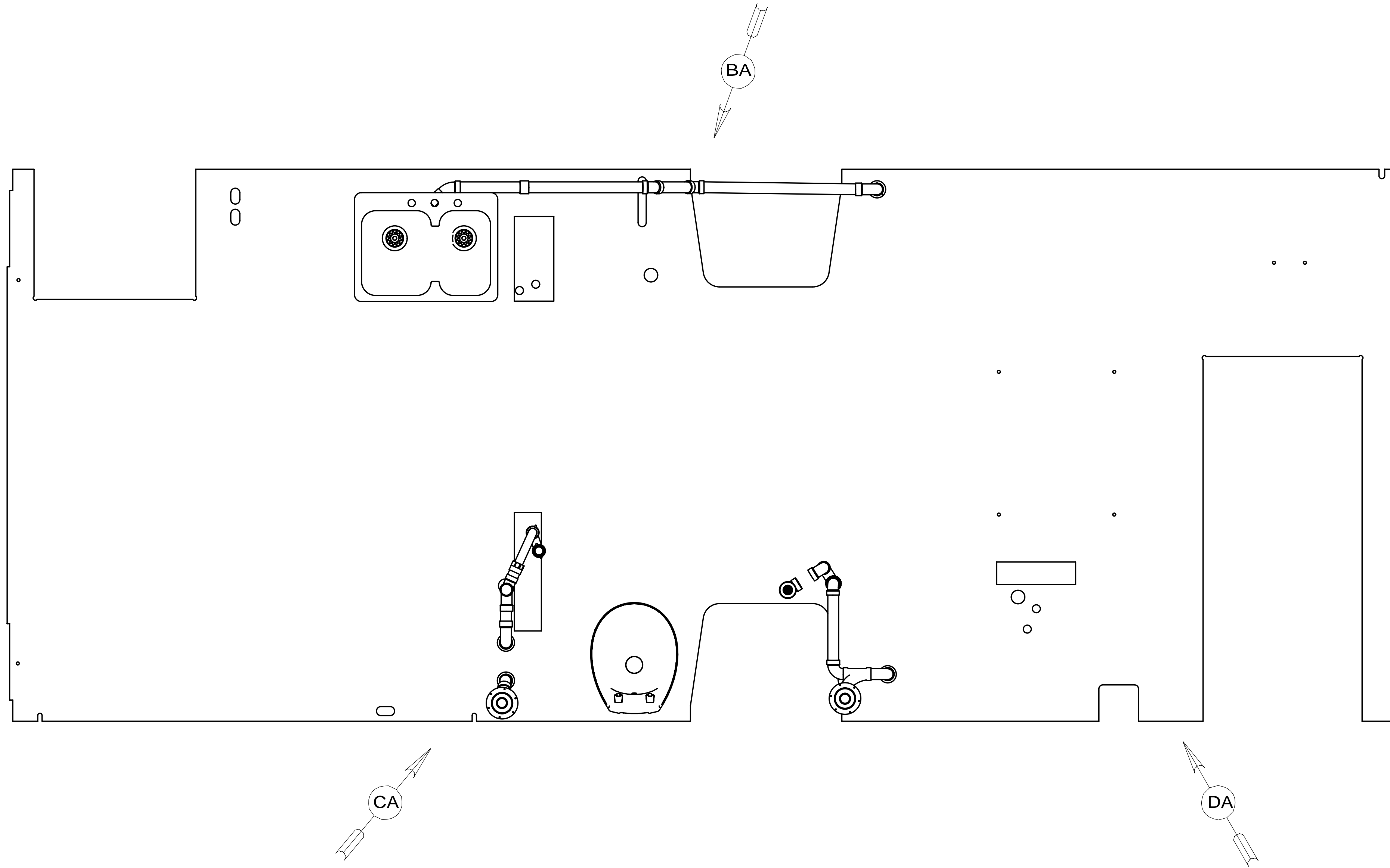

- NOTES:
1. SLOPE OF HORIZONTAL PIPING TO BE MINIMUM OF 3 PER 305 mm.
 2. SLOPE OF TRAP ARM MUST BE 6 PER 305 mm.
 3. ALL PIPE AND FITTINGS TO BE ASSEMBLED WITH SOLVENT 004020-01-000 (USA), 004020-02-000 (CAN)
 4. USE SMOOTH PLUMBERS PUTTY 167459-01-000 TO SEAL STRAINER (0.2 PER STRAINER).
 5. SEAL AROUND SHOWER WITH SILICONE.
 6. VENT PIPE MUST PROJECT 51 MIN AND 64 MAX ABOVE ROOF FOR PROPER FIT AND FUNCTION. ADD S-1 (116666-01-CHT SEAL-VENT PIPE) AROUND PIPE ON ROOF BEFORE VENT CAP IS INSTALLED.
 7. SECURE VENT PIPE TO FLOOR WITH CLAMP 062401-02-000 (2), SCREW 000G67-10-12U (2), BRACKET 136878-01-CHT (2).
 8. SECURE DRAINAGE PIPES TO CABINET USING WIRE TIE 108046-02-000, AND SCREW 000G67-10-12U AT INTERVALS OF NOT MORE THAN 4 FEET APART.
 9. SEE DRAWING 061607 FOR INSTALLATION OF GROMMETS.
 10. SEE WIRING INSTL-BODY FOR ELECTRICAL CONNECTION.
 11. PREP THE SURFACE PER MANUFACTURERS INSTRUCTIONS BEFORE APPLYING THE HEATING PAD.
 12. CUT PART TO 90mm.

- (265) CODES/STANDARDS-CSA/CMVSS
- (23T) DRAINAGE SYSTEM-HEATED
- (1B1) CODES/STANDARDS USA

WINNEBAGO		COPYRIGHT 2014 WINNEBAGO INDUSTRIES, INC.	
DFT-ORIG	ORIG. DATE	ALL DIMENSIONS ARE IN MILLIMETERS	
CHKR		FIRST USED	
P.E.		14 327Q / QP	
M.E.		UNSPECIFIED TOLERANCES ARE:	
DSNR		WHOLE DIM (X)	: 3
		ONE-PLACE (X.X)	: 1.5
		TWO-PLACE (X.XX)	: 0.50
		ANGLE	: 1°
THIRD ANGLE PROJECTION		MATERIAL:	
DO NOT SCALE DRAWING		REFER TO ES0018 FOR FASTENER TIGHTENING GUIDELINES	
TITLE: DRAINAGE SYSTEM INSTL			
SHEET 1 OF 5	PART NO	186159	REV
REF:	1	26-Mar-2014	

FOR
DRAINAGE
CALLOUTS
SEE DWG NO
116229-01-000

* 186159 *

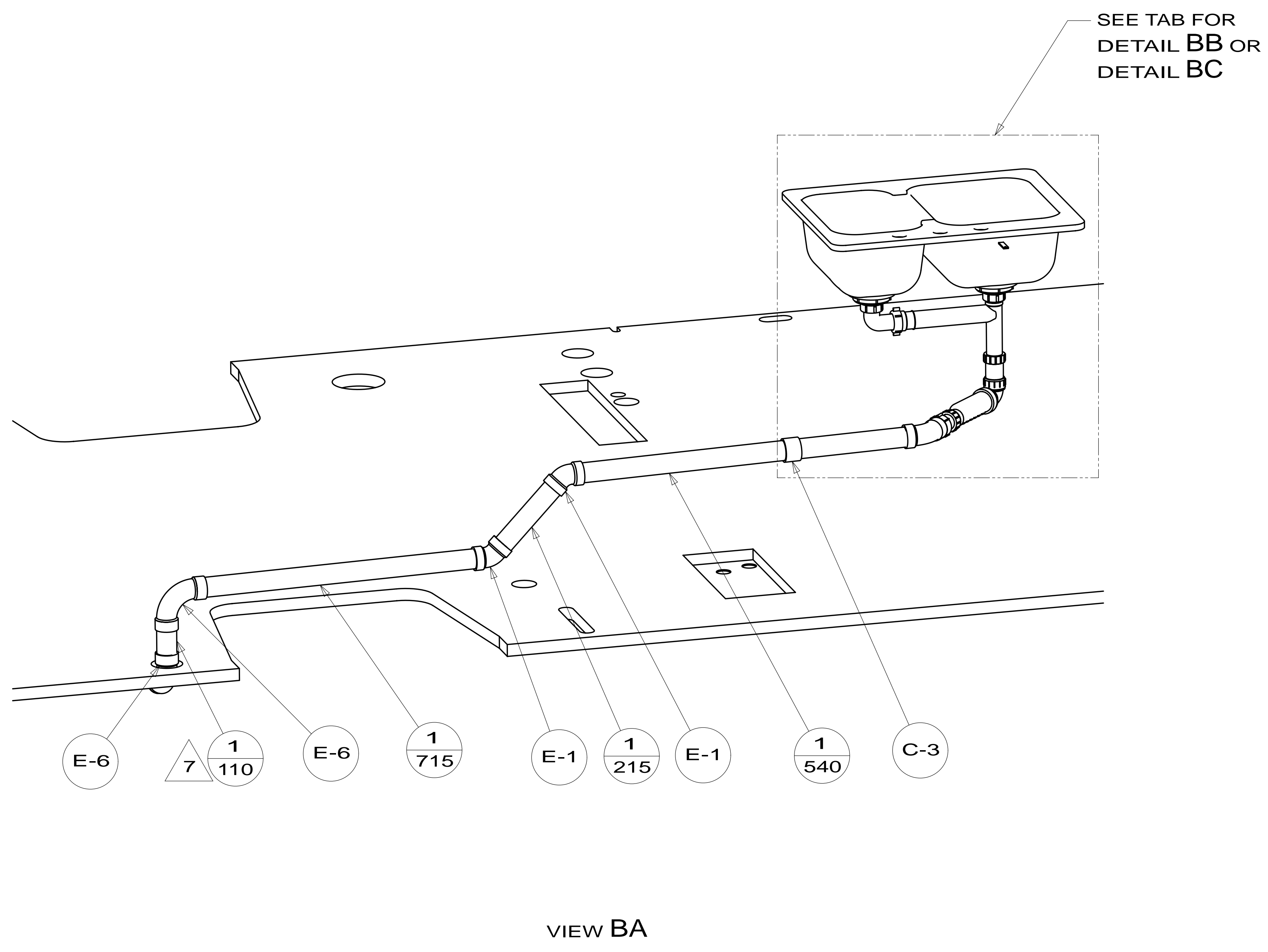
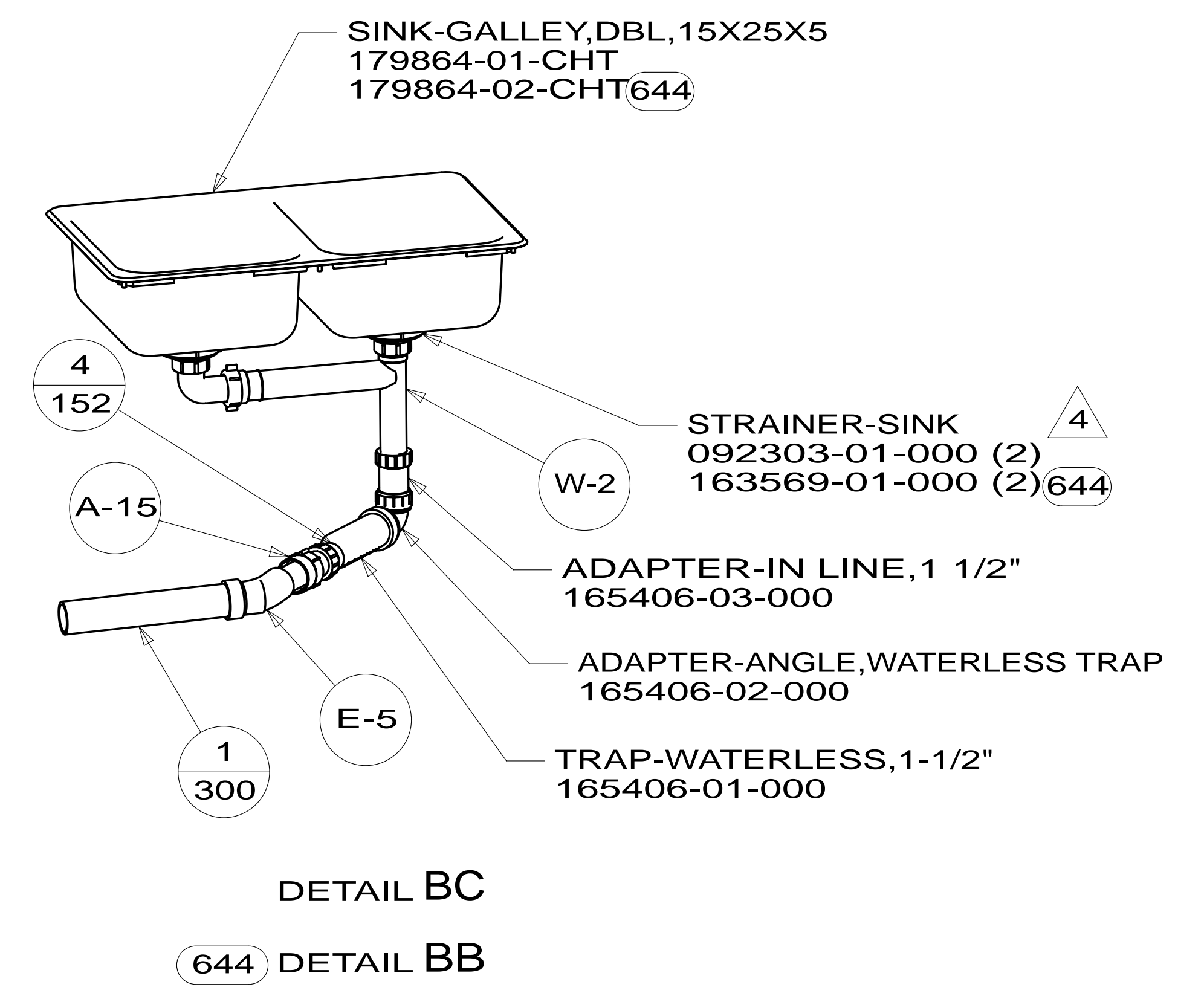
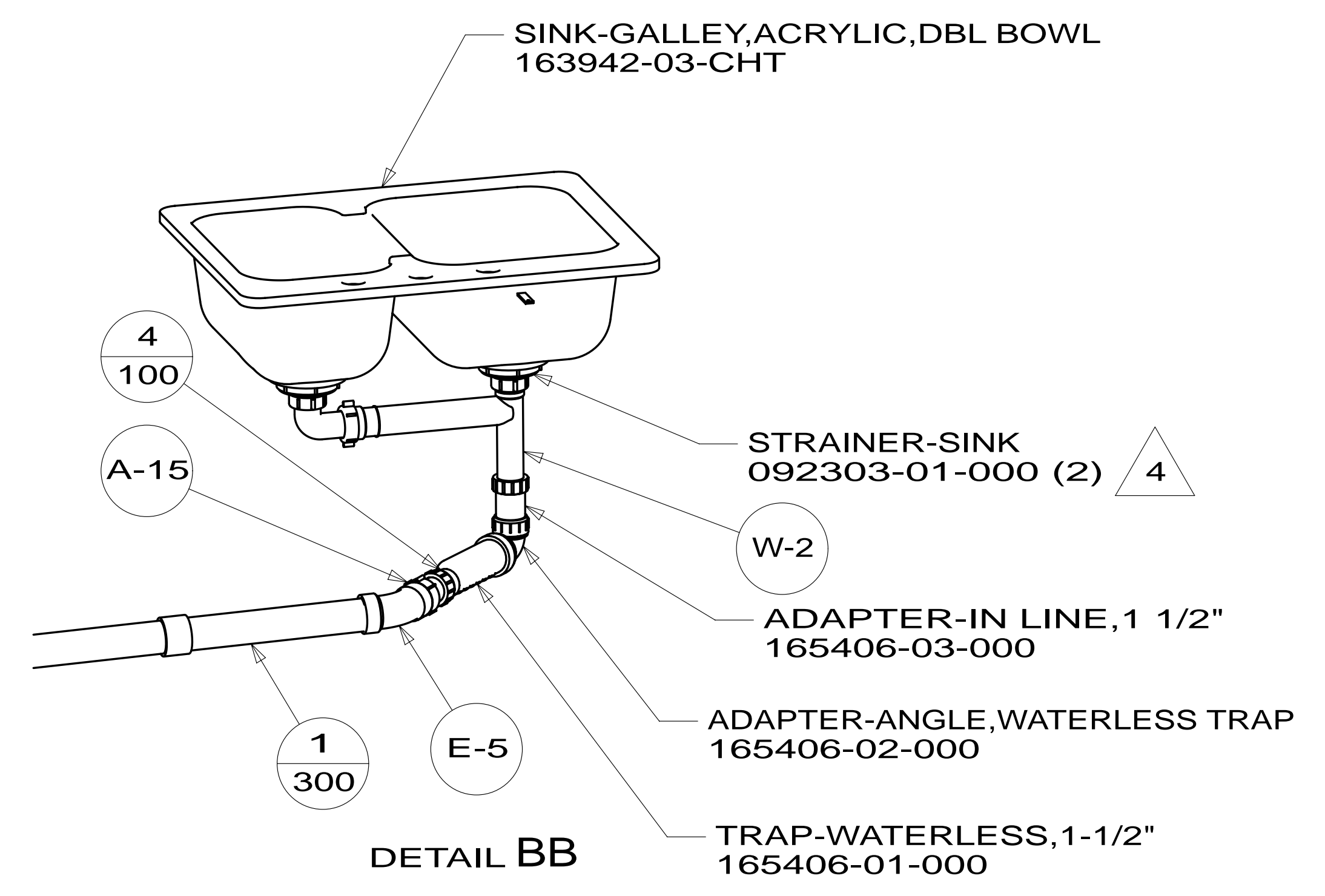

FIRST USED	14 327Q / QP		
TITLE:	DO NOT SCALE DRAWING		
TITLE:	DRAINAGE SYSTEM INSTL		
SHEET 2	PART NO	186159	REV
			26-Mar-2014

* 186159 * A

TOILET-RESIDENCE, HI, W/O SPR
184093-02-CHT
160815-03-CHT (644)

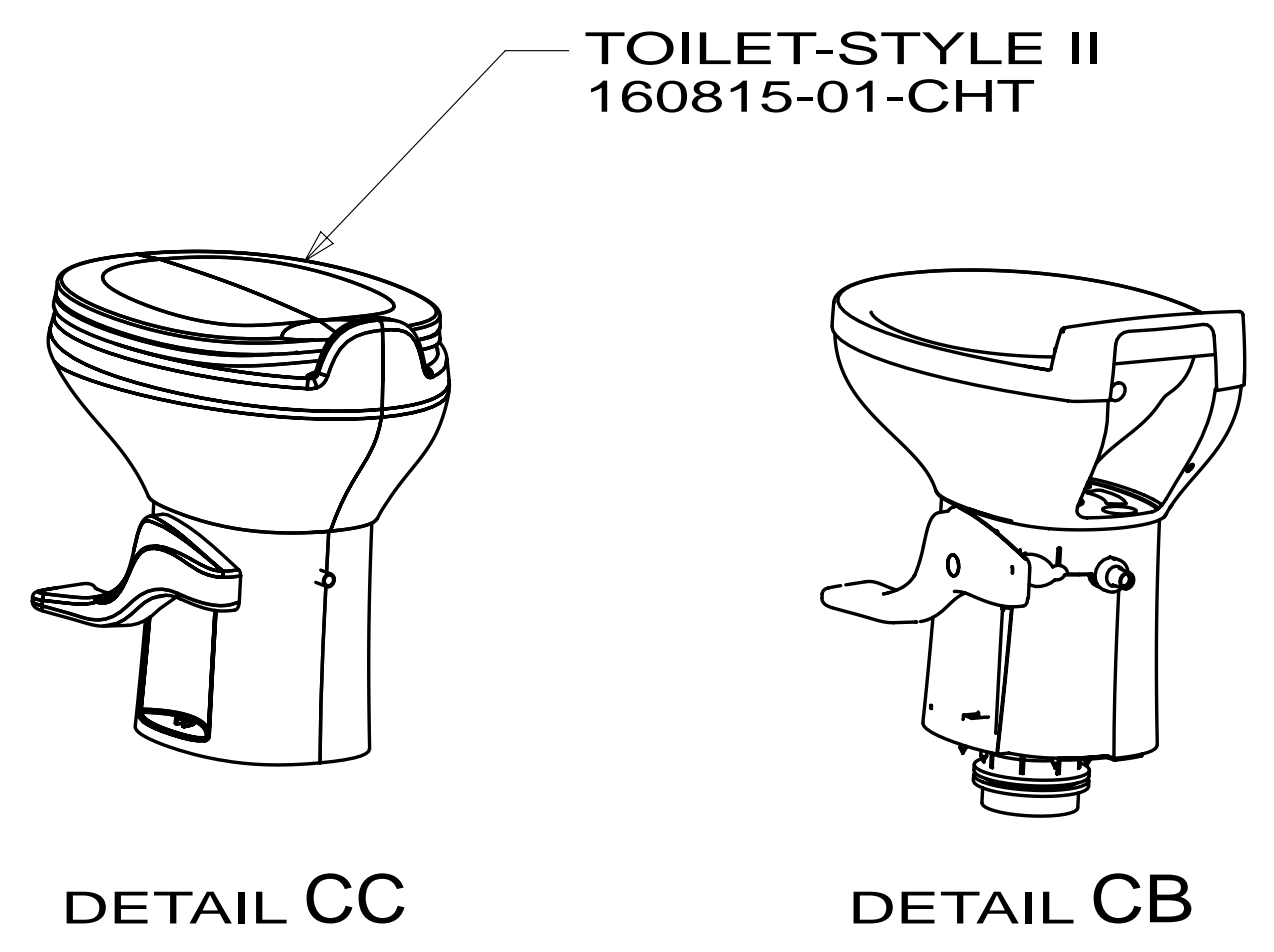

SHOWER INSTL
147883-05-000
STRAINER W/RUBBER WASHER
066440-01-000

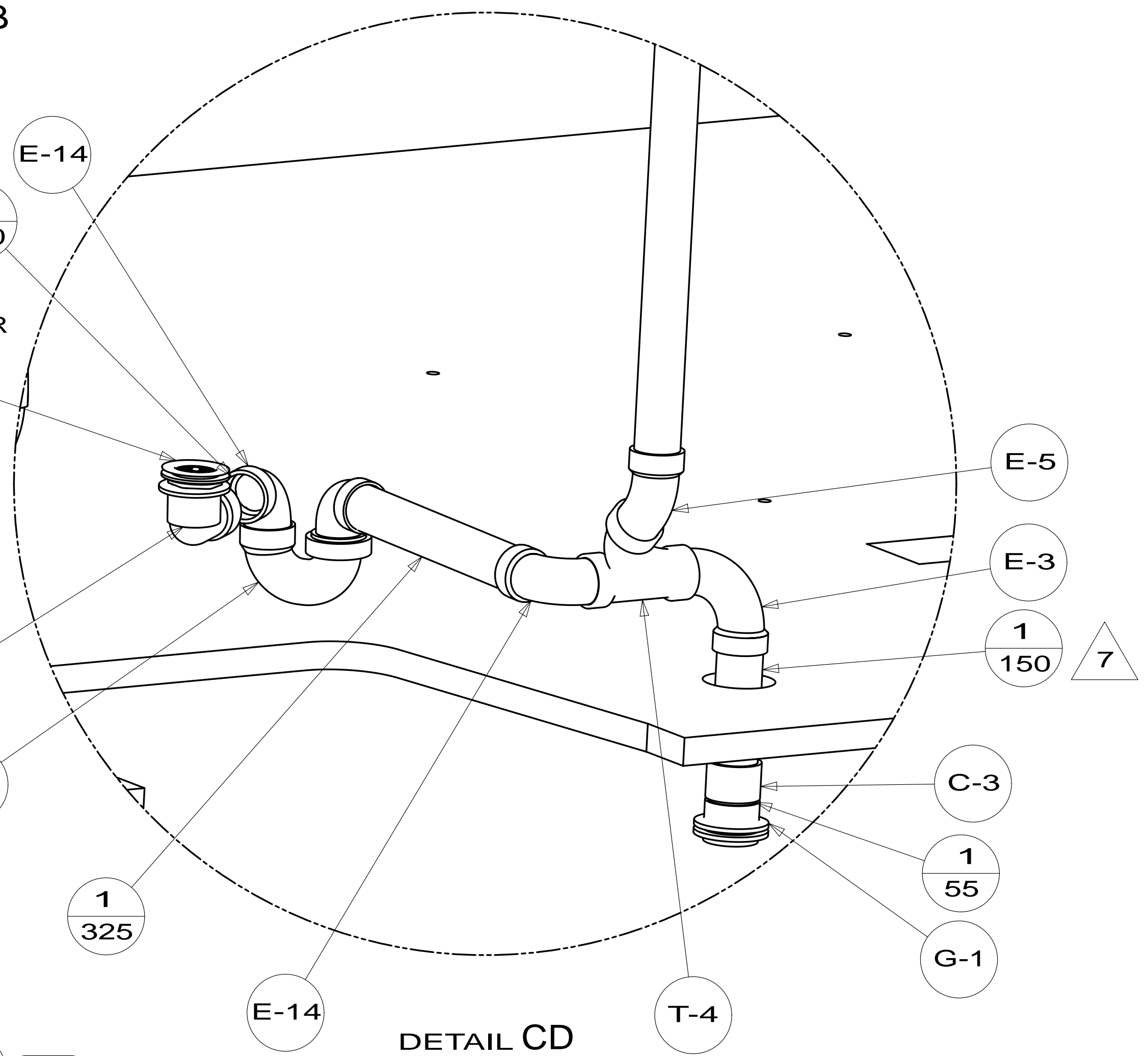

SEE TAB FOR
DETAIL CE OR
DETAIL CF

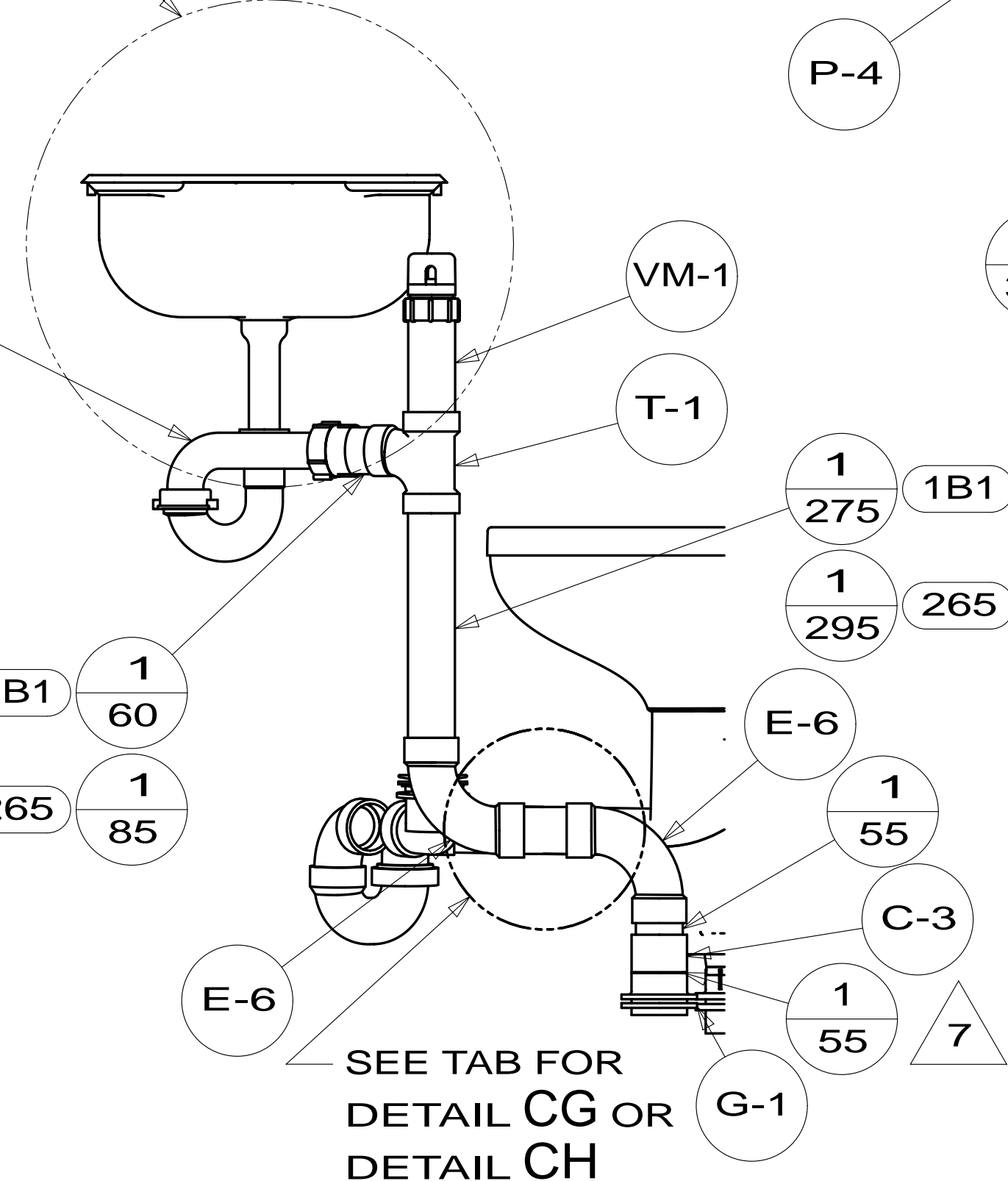

SEE TAB FOR
DETAIL CC
OR DETAIL CB

SCREW
087721-01-000 (8)

NIPPLE
010129-02-000 (12)

VIEW CA

SINK-LAVATORY
096927-01-CHT

SINK-LAVATORY, OVAL
184546-01-CHT
STRAINER ASM
106116-01-CHT

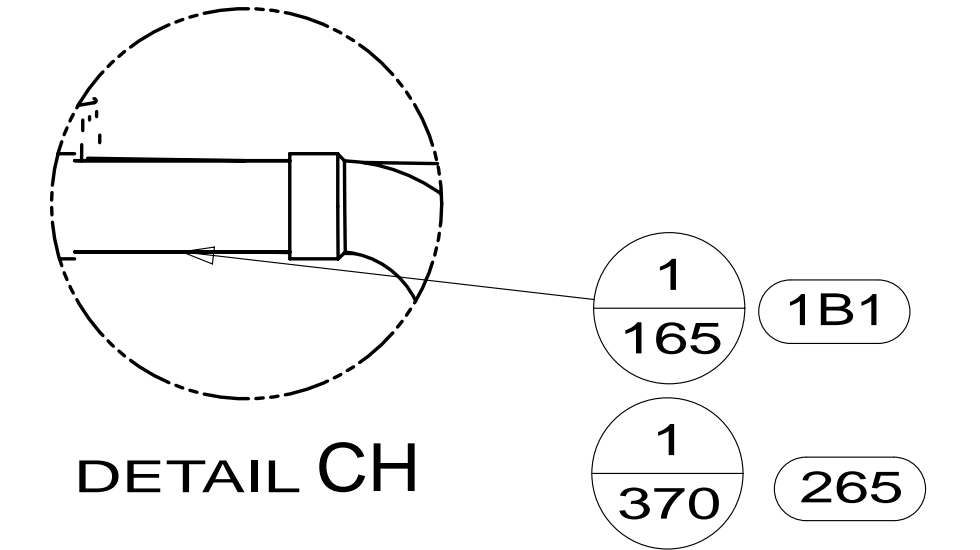

FIRST USED	14 327Q / QP	
TITLE:	DO NOT SCALE DRAWING	
TITLE:	DRAINAGE SYSTEM INSTL	
SHEET 3	PART NO	186159
	REV	
		26-Mar-2014

A * 186159

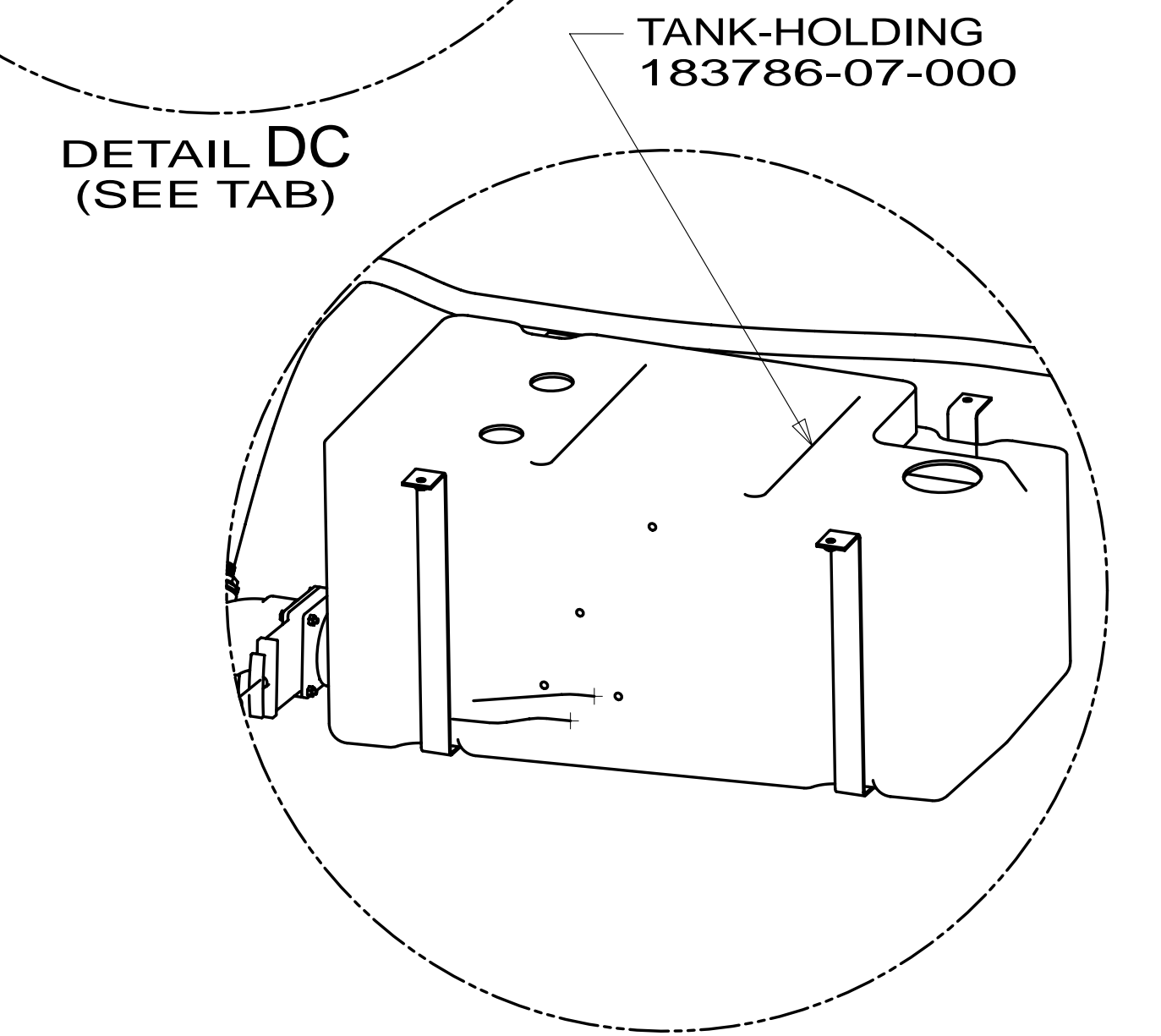
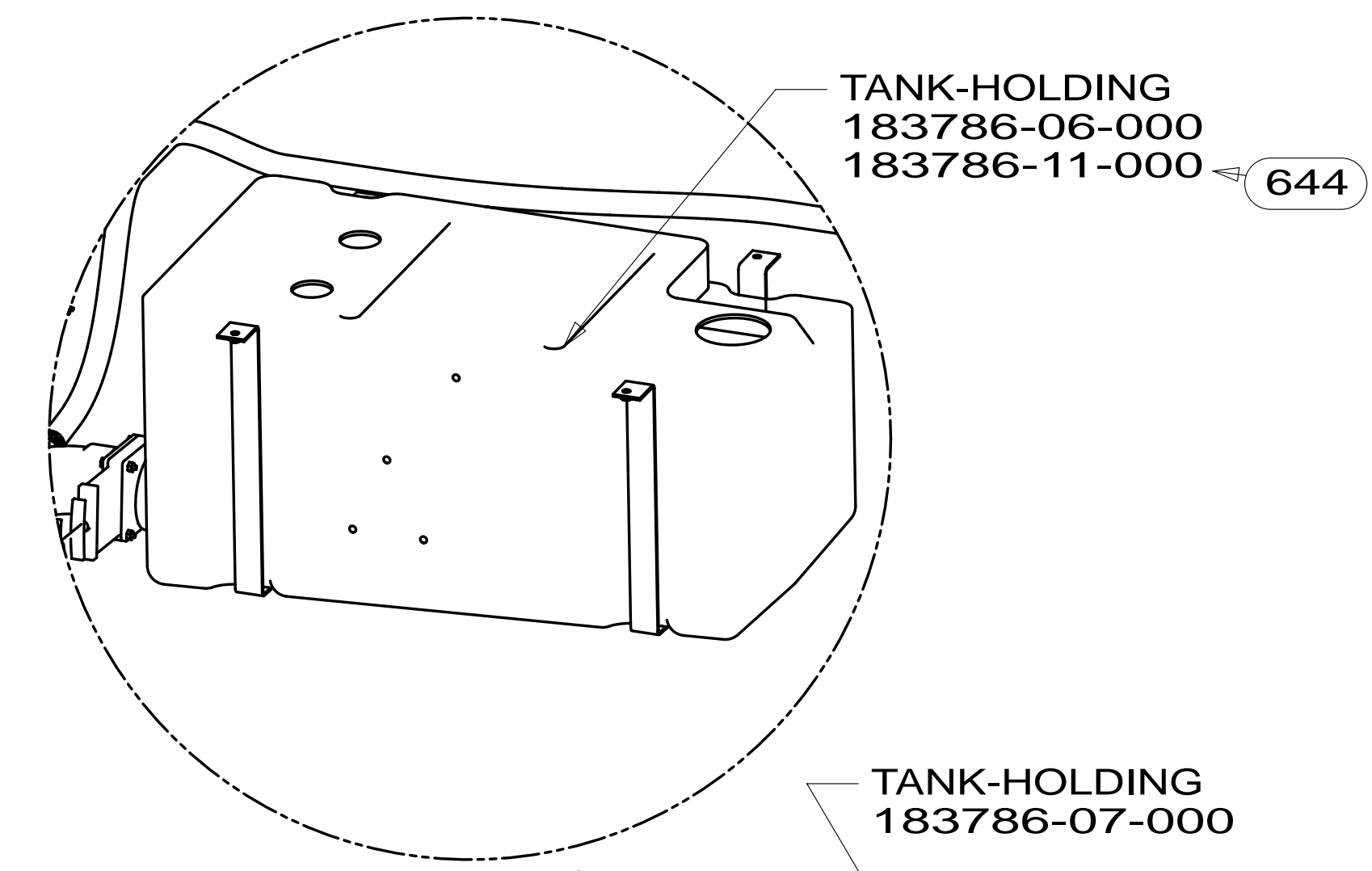
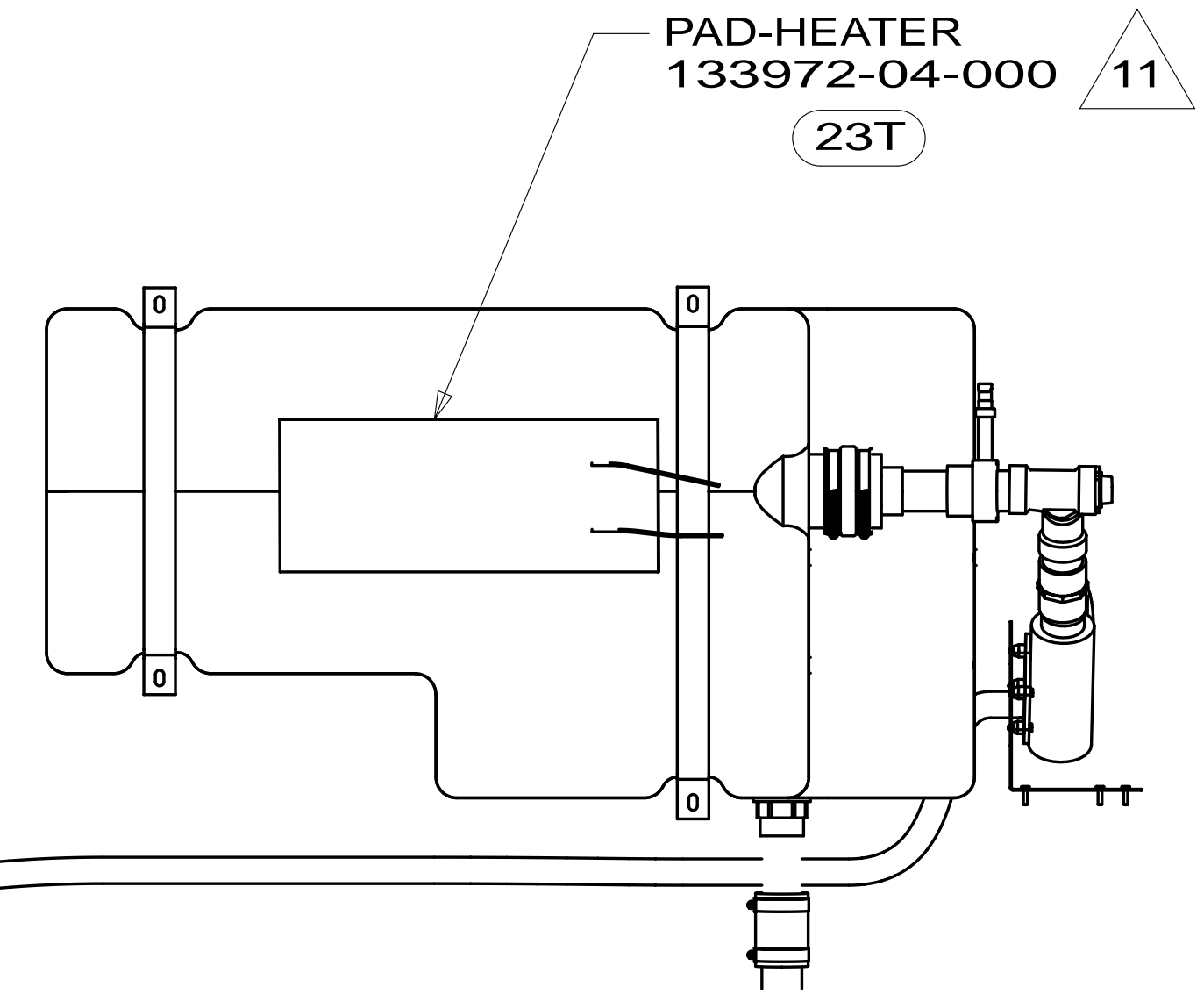
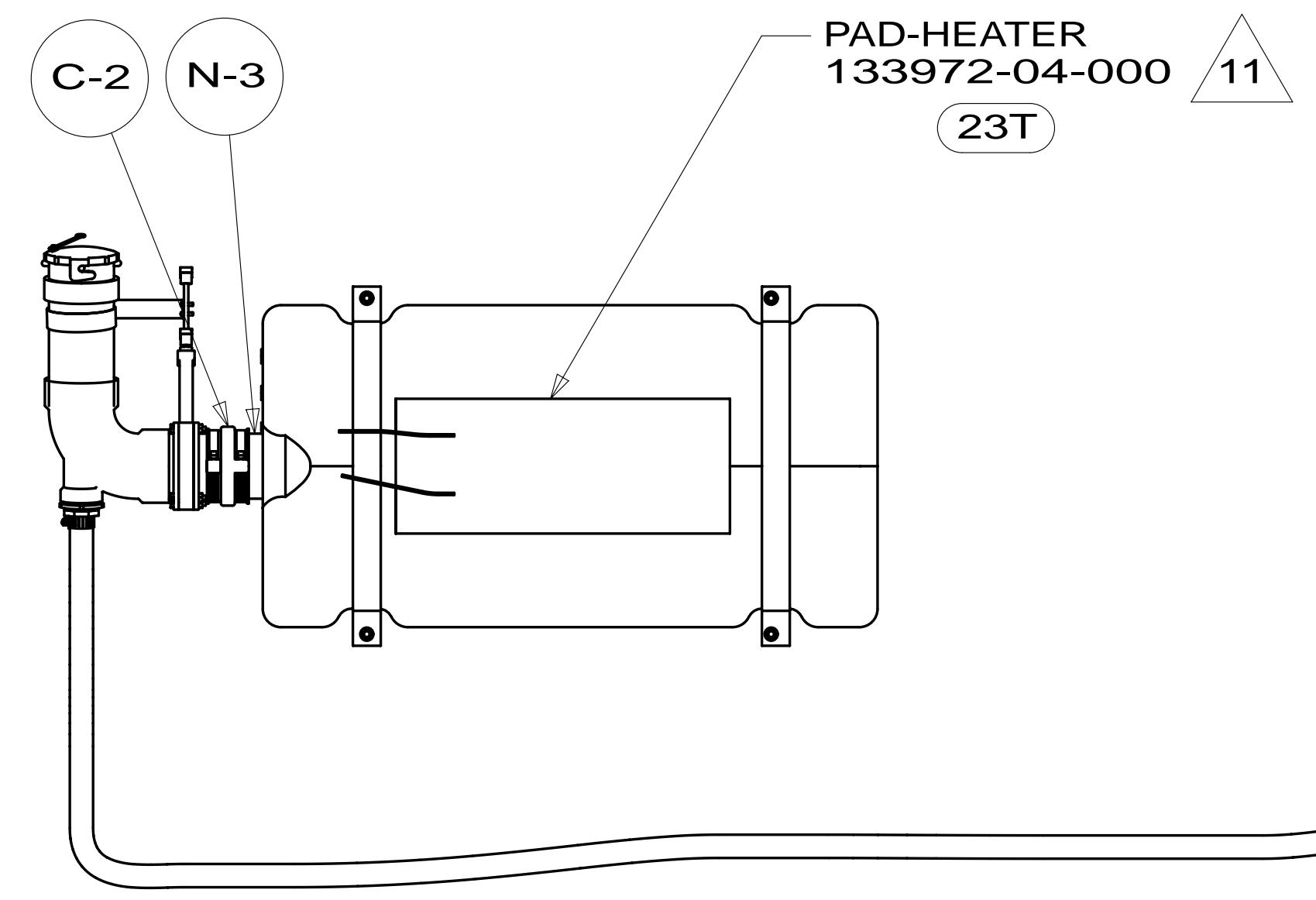

DETAIL DC OR DD
STRAP-W/HOLES
133939-06-CHT
HOLDER-RING
141443-05-CHT
SCREW
000G39-08-12U (2)
BOLT
000C26-05-16U
NUT
000D39-05-00U

DETAIL DB

CLAMP-HOSE WORMGEAR
062401-01-000

FITTING-ADAPTER
170876-01-000

HOSE
177021-01-000
(4270)
(WIRE TIE MACERATOR PUMP
HOSE UP TO THE CHASSIS
FRAME ASM)

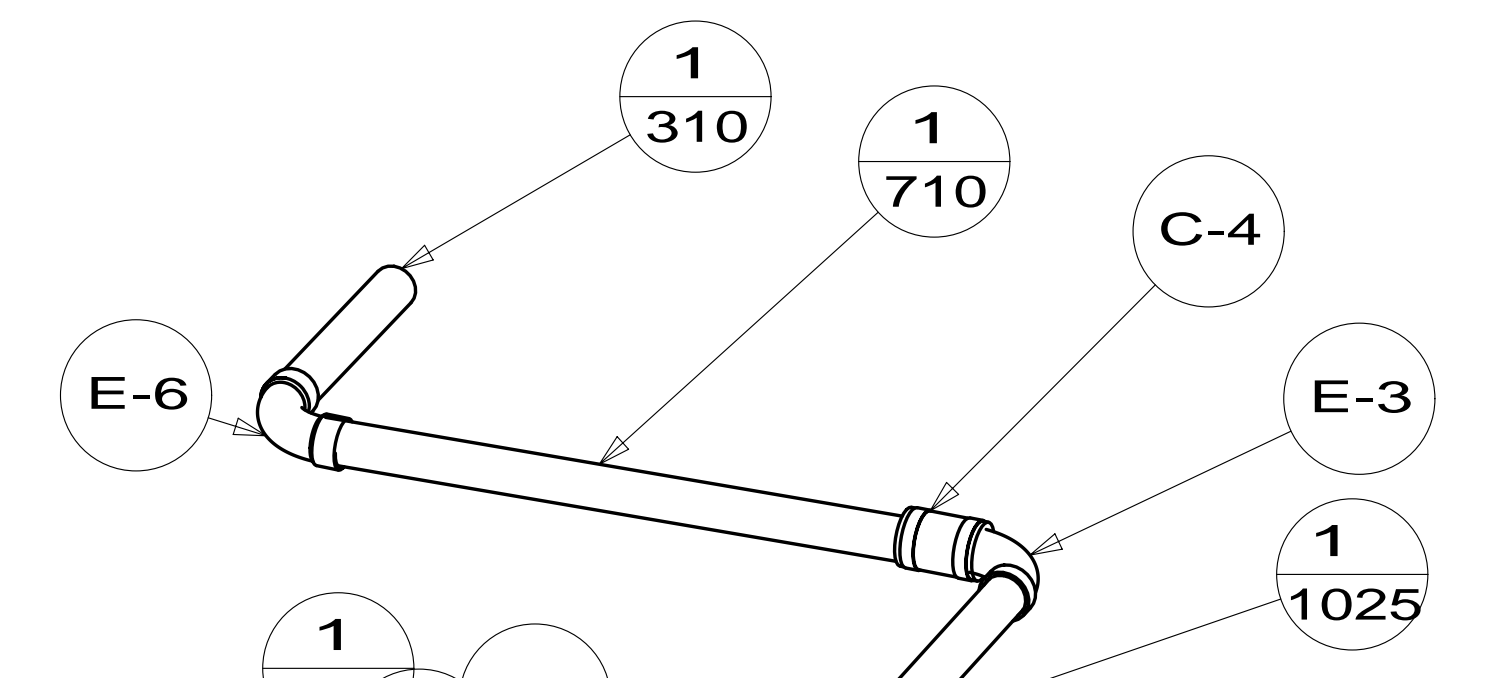

PLATE-MOUNTING
174790-02-CHT
SCREW
000G39-10-12U (4)

PUMP-MACERATOR
165762-02-000 10
SCREW
000G39-10-16U (4)

STRAP-HLDG TANK MTG
153148-22-CHT
NUT
000D39-05-00U (2)

644 TANK ASM-HOLDING
186663-02-000
186663-03-000

STRAP-HLDG TANK MTG
153148-23-CHT
NUT
000D39-05-00U (2)

STRAP-HLDG TANK MTG
153148-13-CHT
NUT
000D39-05-00U (2)

STRAP-HLDG TANK MTG
153148-12-CHT
NUT
000D39-05-00U (2)

DETAIL DA

644 GREAT ALASKAN RENTAL PACKAGE

FIRST USED	14 327Q / QP	
DO NOT SCALE DRAWING		
TITLE: DRAINAGE SYSTEM INSTL		
SHEET 4	PART NO 186159	REV
		26-Mar-2014

A * 186159

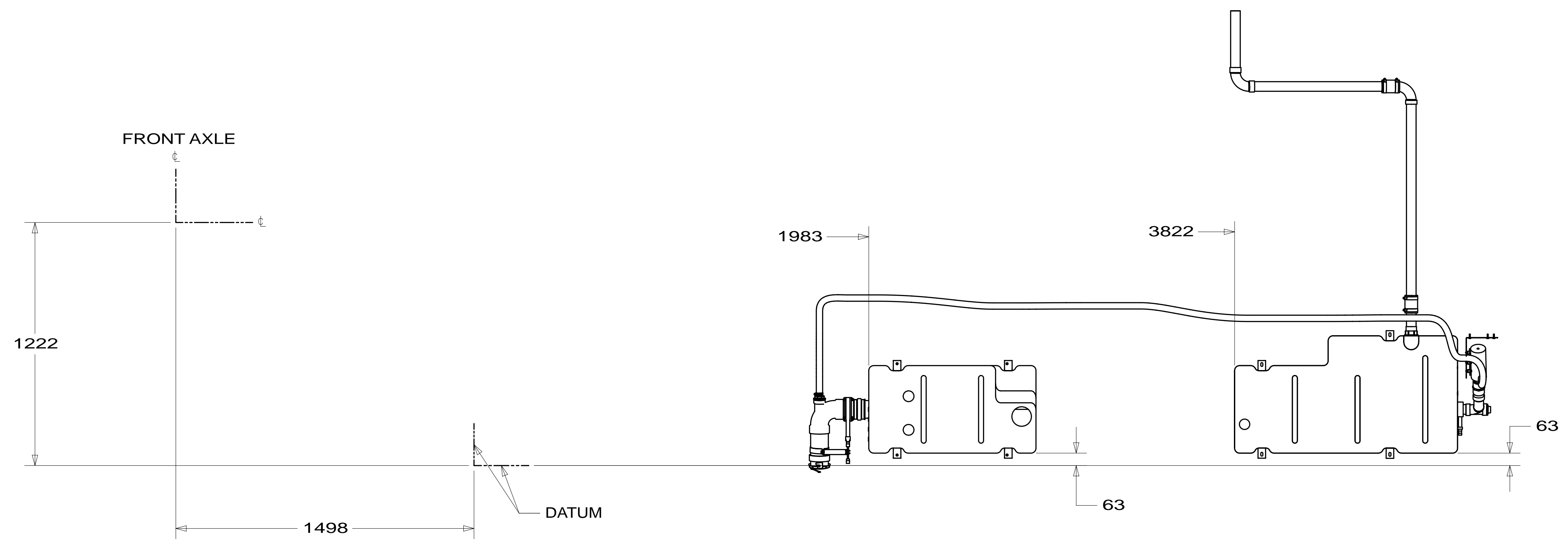

FIRST USED	14 327Q / QP	
DO NOT SCALE DRAWING		
TITLE: DRAINAGE SYSTEM INSTL		
SHEET 5	PART NO 186159	REV
		1 26-Mar-2014

* 186159 * A

DWG NO	MODEL	DETAIL BB OR BC	DETAIL CB OR CC
186162-01	327Q	BB	CC
186162-02	327QP	BC	CB

RELEASE	REV DATE	DWG NO	186162
REV ZONE	REVISION RECORD	DATE	DTR-ORIG

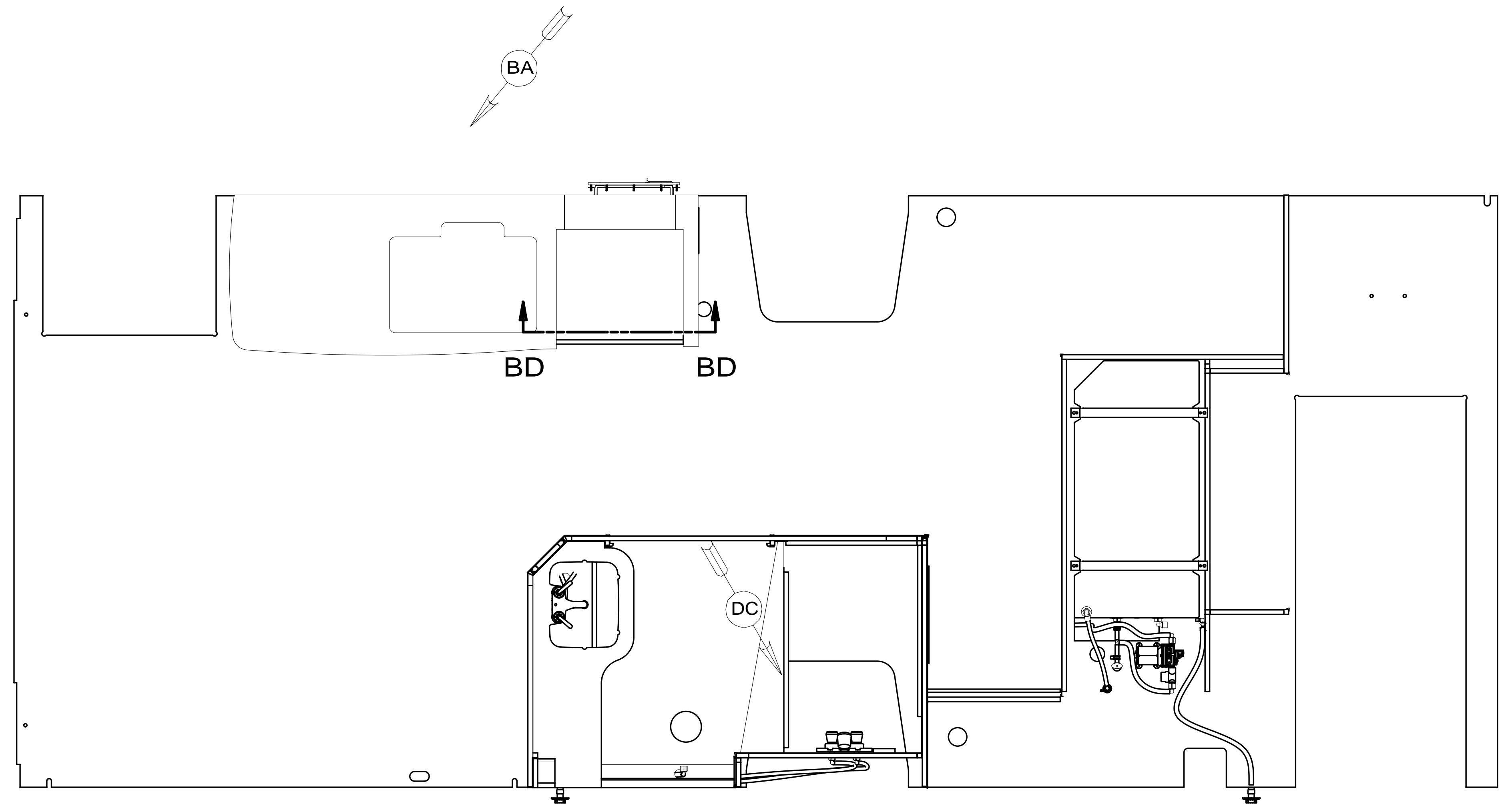

- 10 NOT USED WITH 644 .
- 9 FASTEN PLATFORM TO FLOOR AFTER SIDEWALL IS SET AND HEATER IS ATTACHED TO WALL.
- 8. ALL CRIMP FITTINGS TO 1/2" PEX TUBING REQUIRE 1/2" CLAMP 140171-03-000.
- 7. ALL CRIMP FITTINGS TO 5/8" PEX TUBING REQUIRE 5/8" CLAMP 140171-04-000.
- 6 LABEL HOT AND COLD SUPPLY TUBES AND TAPE FITTING TO TUBE BEFORE CABINET SET TO PREVENT MOVEMENT.
- 5 ADD PIPE WRAP (LADDER SCRAP 110157-02-000) INSULATION.
- 4 ADD TEFLON TAPE 010405-02-000.
- 3. ALL TUBING TO BE SECURED AT 1200 INTERVALS MAXIMUM WITH CLAMP 010495-01-000 AND SCREW 000G67-10-12U OR EQUIVALENT.
- 2. TUBING TO BE INSTALLED WITH SUFFICIENT SLOPE TO PROVIDE DRAINAGE TO NEAREST VALVE.
- 1. PLASTIC FITTINGS TO BE SEALED WITH SEALANT 084456-01-000.

644 GREAT ALASKAN RENTAL PACKAGE

		COPYRIGHT 2014 WINNEBAGO INDUSTRIES, INC.
DTR	ORIG. DATE	
CHKR	ALL DIMENSIONS ARE IN MILLIMETERS	
P.E.		
M.E.	FIRST USED	
DSNR	14 327Q / QP	
UNSPECIFIED TOLERANCES ARE:		MATERIAL:
WHOLE DIM (X)	: 3	
ONE-PLACE (X.X)	: 1.5	
TWO-PLACE (X.XX)	: 0.50	
ANGLE	: 1°	
THIRD ANGLE PROJECTION		
DO NOT SCALE DRAWING		REFER TO ES0018 FOR FASTENER TIGHTENING GUIDELINES
TITLE: WATER SYSTEM INSTL		
SHEET 1 OF 4	PART NO	186162
REF:	1	17-Apr-2014

FOR WATER CALLOUTS SEE DWG NO 116230-01-000

NOTES:

* 186162 * A

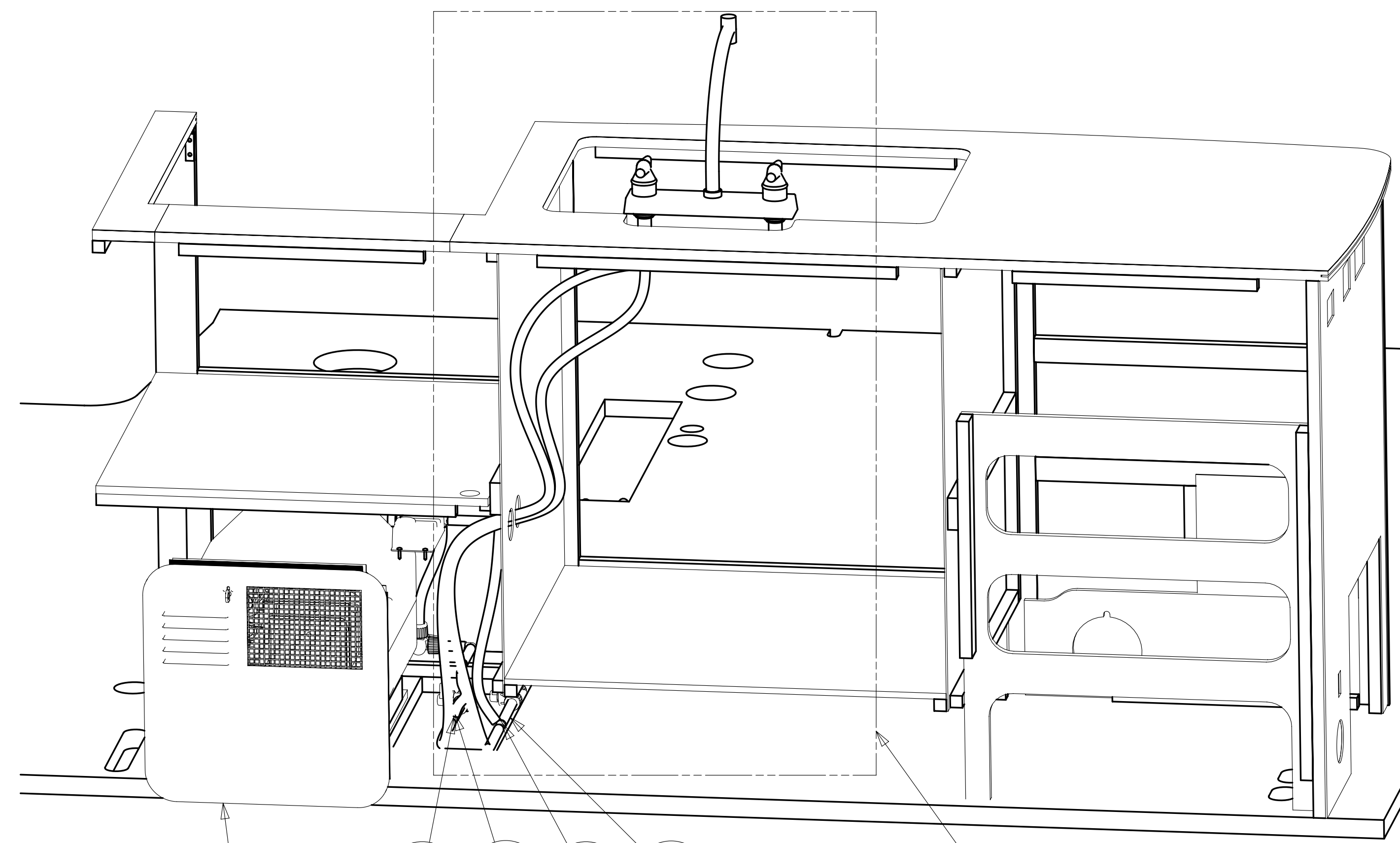

T-28
TU-9 70
T-28
TU10 125

VIEW BA

SEE TAB FOR
VIEW BB OR
VIEW BC

WATER HEATER INSTL-6 GAL
186899-04-000
PLATFORM
184166-01-000
SCREW
000G67-10-16U (2)

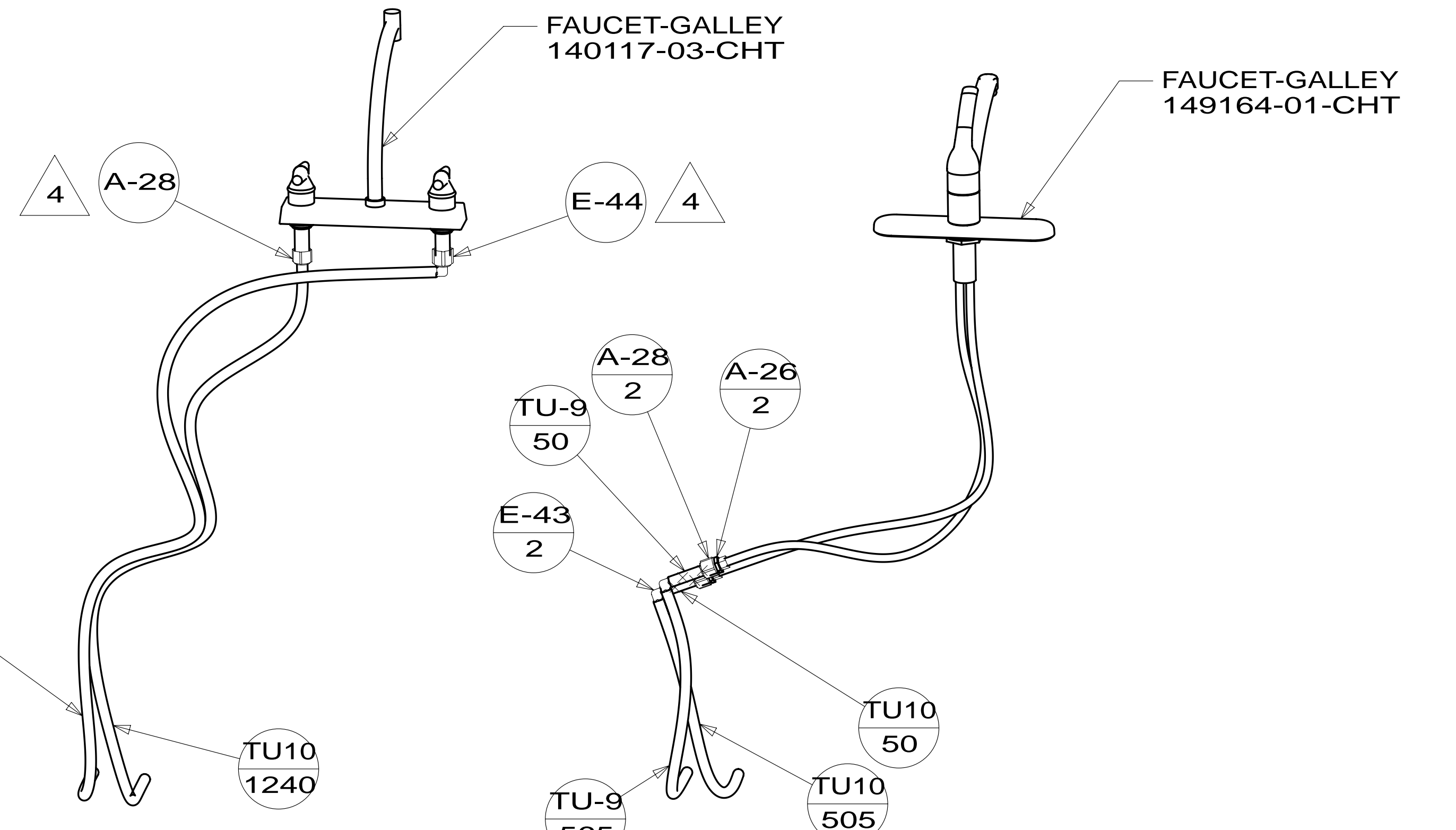

DETAIL BB

DETAIL BC

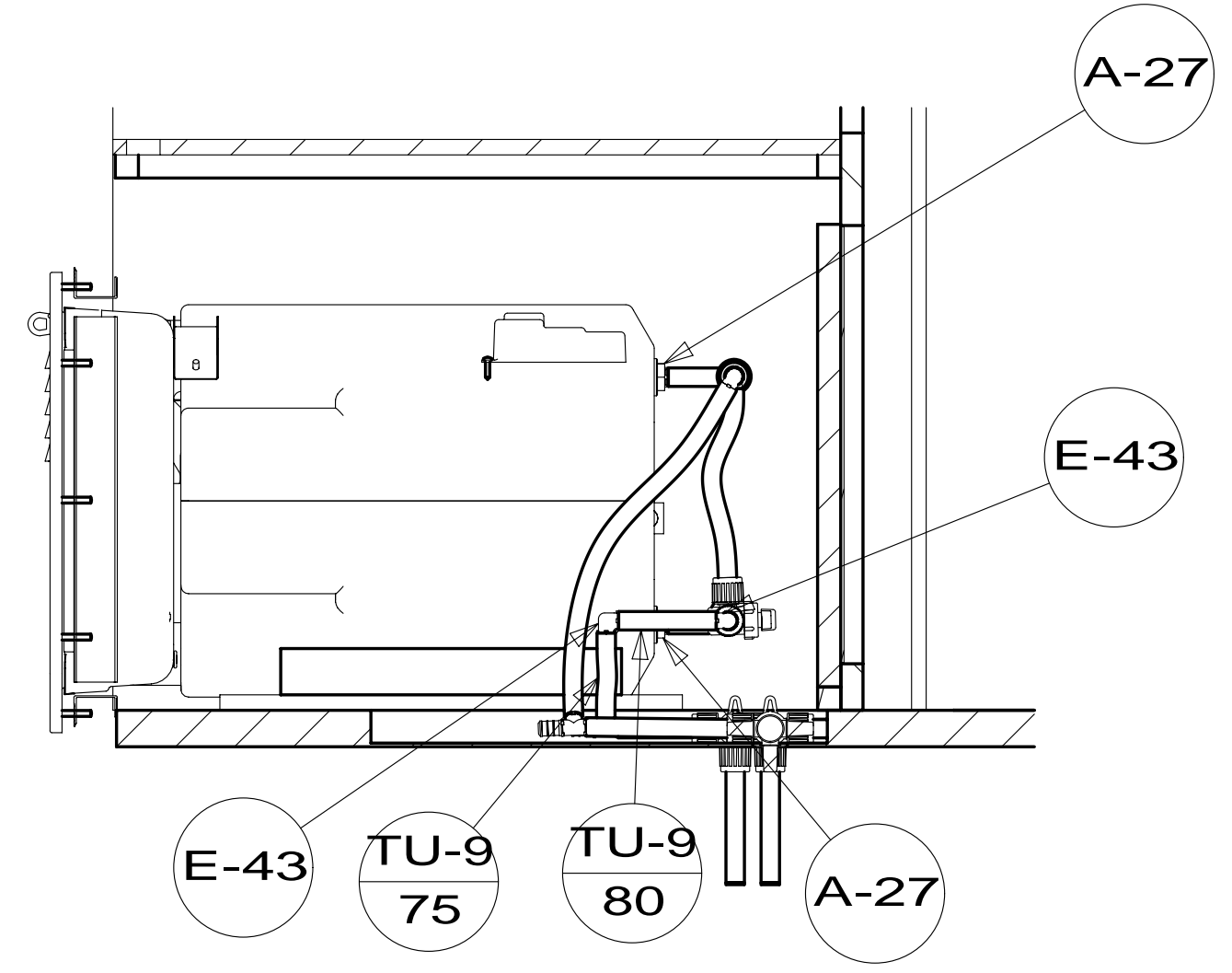

SECTION BE-BE

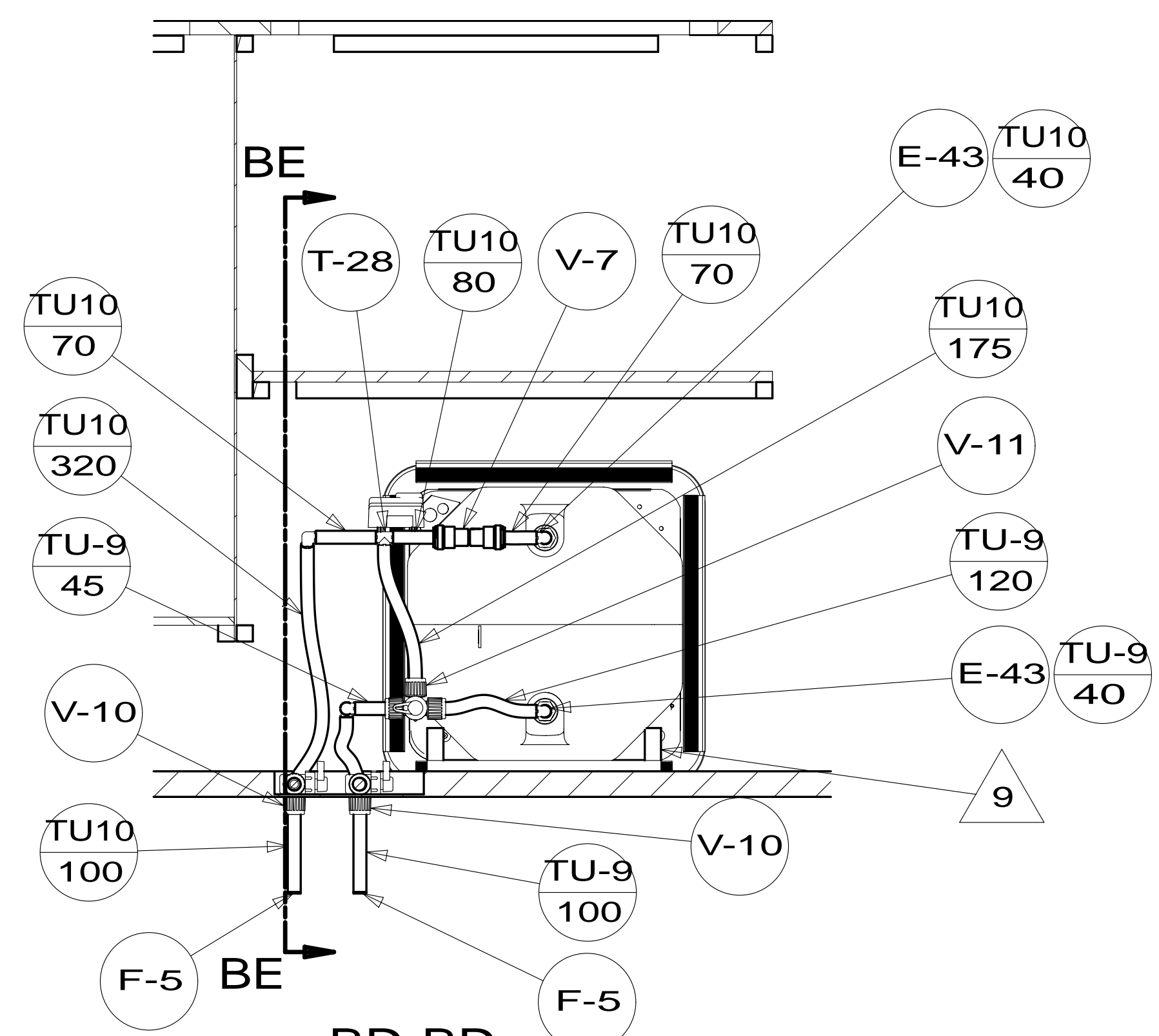

SECTION BD-BD

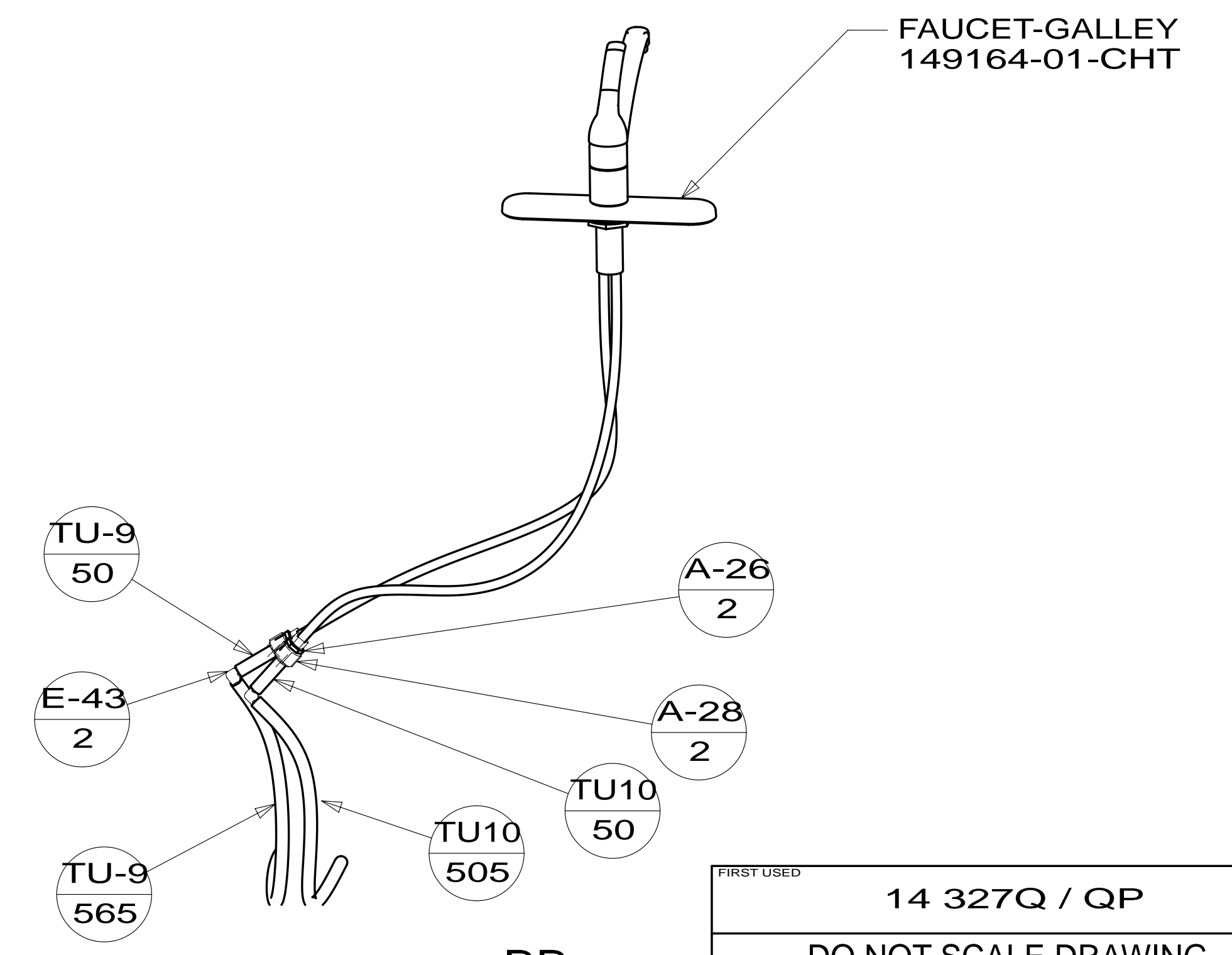

DETAIL BB
644

FIRST USED	14 327Q / QP	
TITLE:	DO NOT SCALE DRAWING	
SHEET 2	PART NO 186162	REV
		17-Apr-2014

A * 186162

FAUCET-LAV,SGL CTRL,NO WASTE
165730-01-CHT

CLAMP
010497-01-000
SCREW
000G67-10-12U (2)
FLUSHING SYSTEM
125697-03-000

BREAKER-VACUUM,FLUSHING SYS
125697-04-000

DETAIL CB
(CABINETS NOT SHOWN
FOR CLARITY)

FAUCET-LAV,DUAL LEVER CTRL
186417-01-CHT
FAUCET-LAV,SGL CTRL,NO WASTE
165730-01-CHT 644

DETAIL CC
(CABINETS NOT SHOWN
FOR CLARITY)

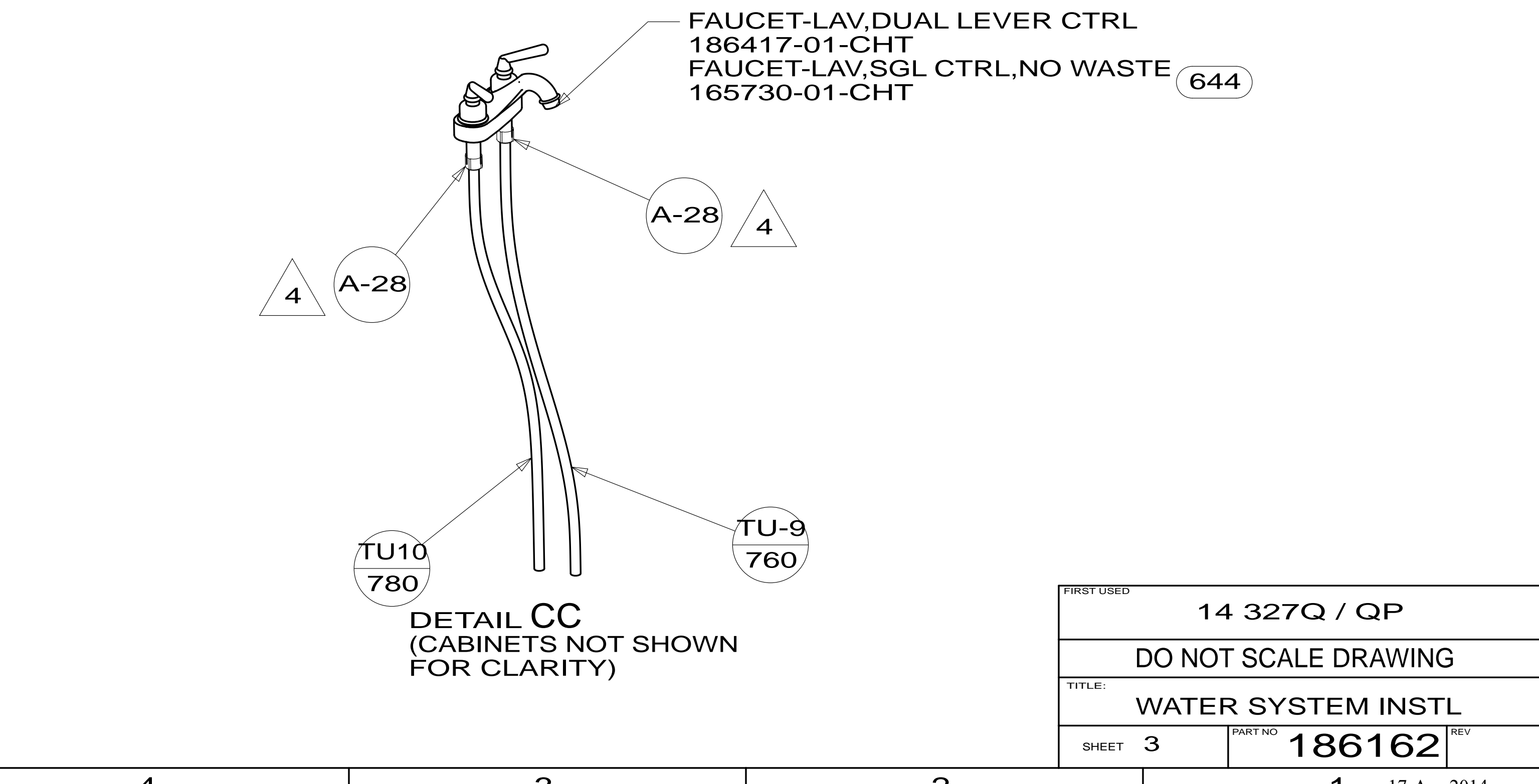
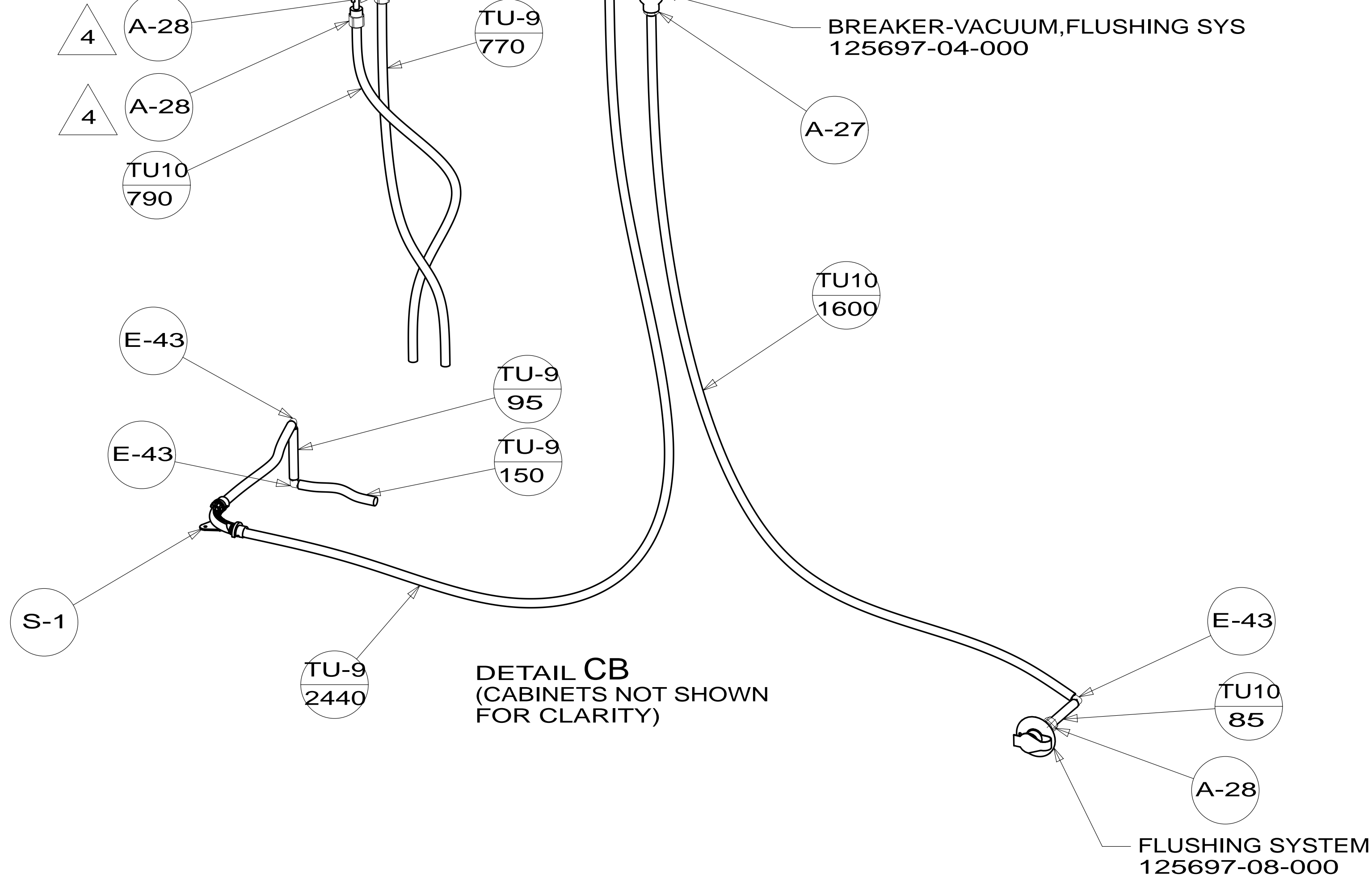
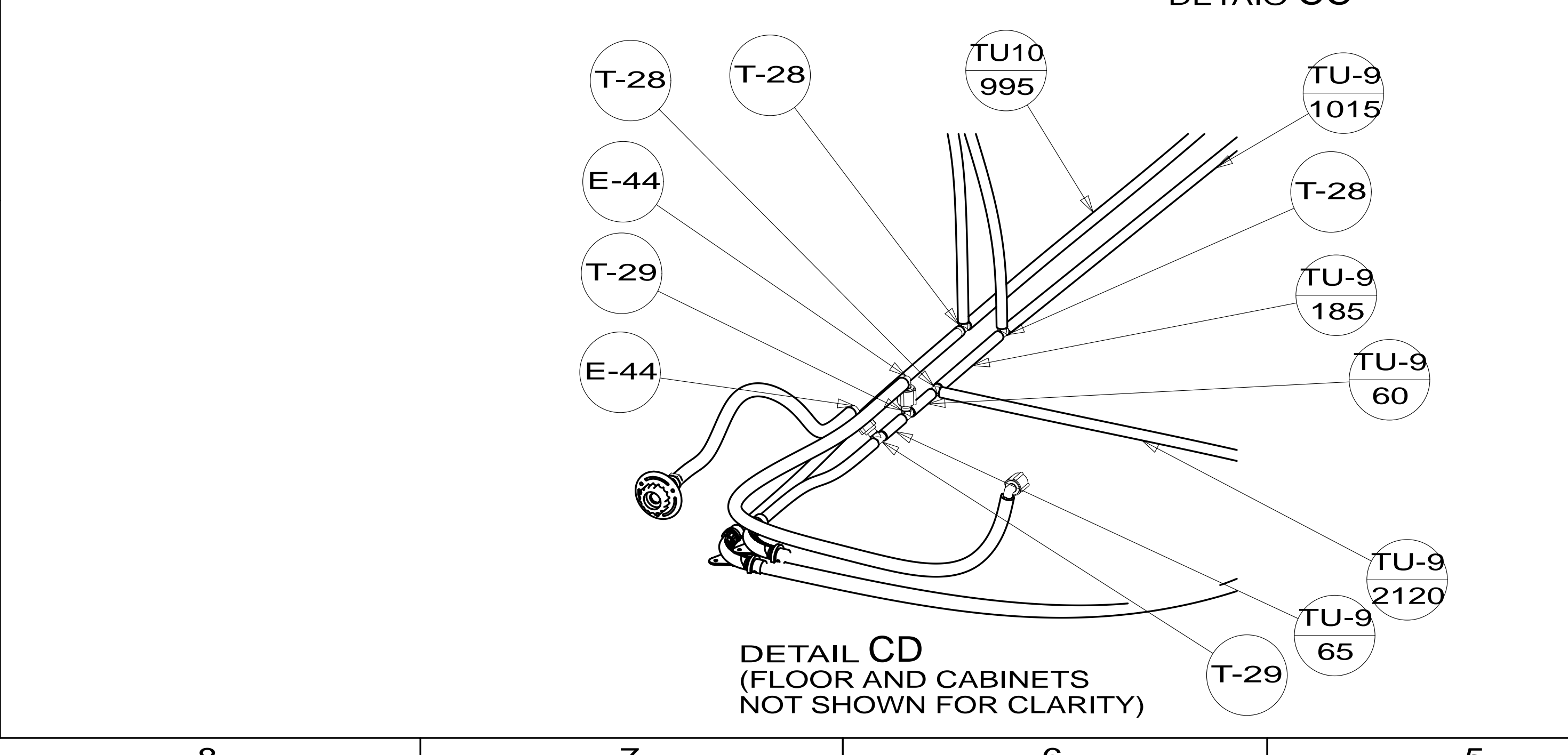
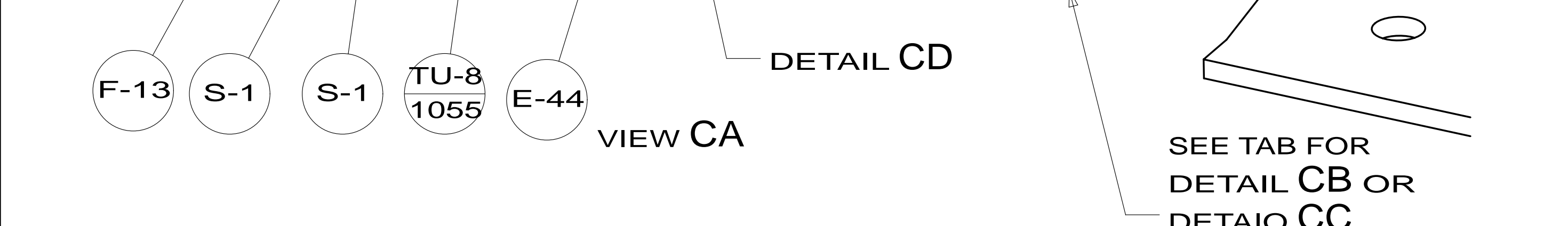
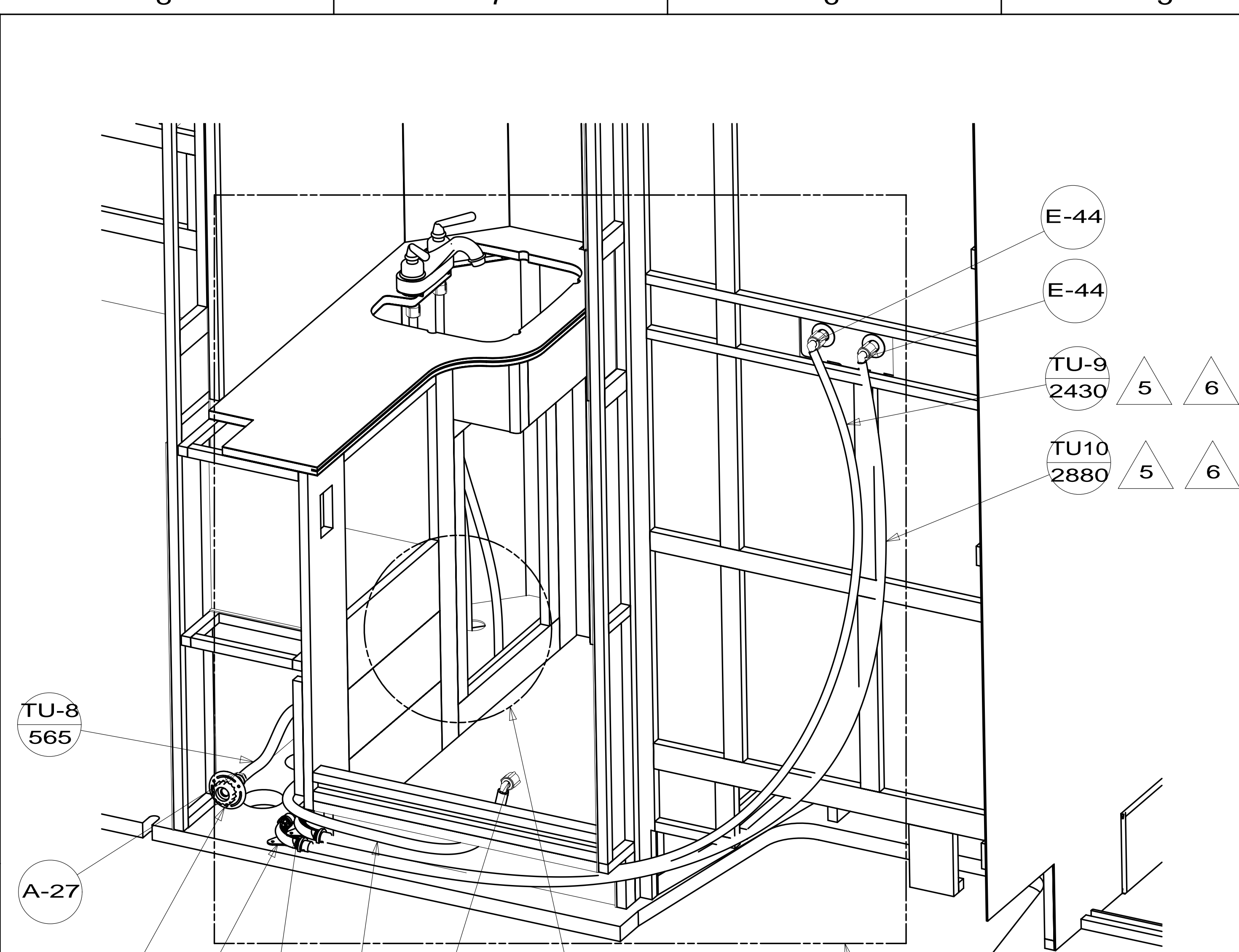

SEE TAB FOR
DETAIL CB OR
DETAIL CC

FIRST USED	14 327Q / QP	
TITLE:	DO NOT SCALE DRAWING	
SHEET 3	PART NO 186162	REV
		17-Apr-2014

* 186162 * A

TANK ASM-WATER,44 GAL
183814-02-000
644 183814-03-000

STRAP-TANK,WATER
118994-10-CHT (2)
NUT
000D39-05-00U (4)

SCREW
000G67-10-12U

CLAMP
010497-01-000

CLAMP
010497-01-000
SCREW
000G67-10-12U

PANEL-SHOWER FAUCET
167738-02-CHT

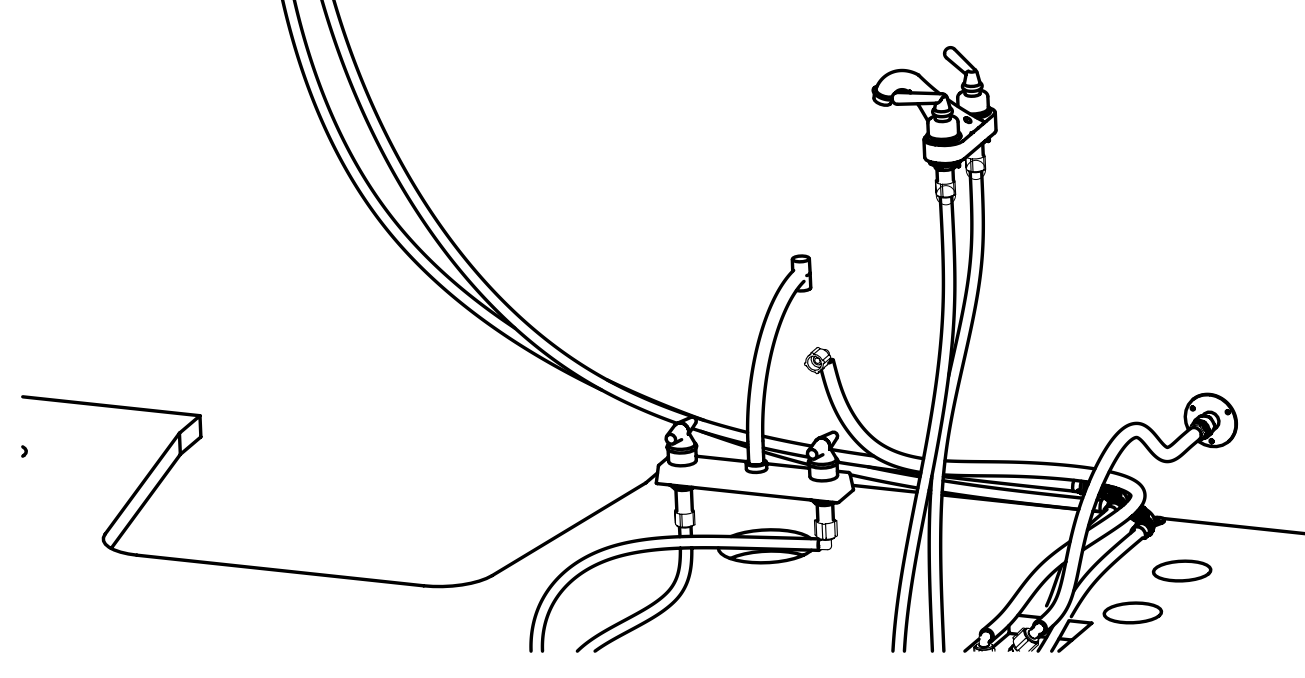
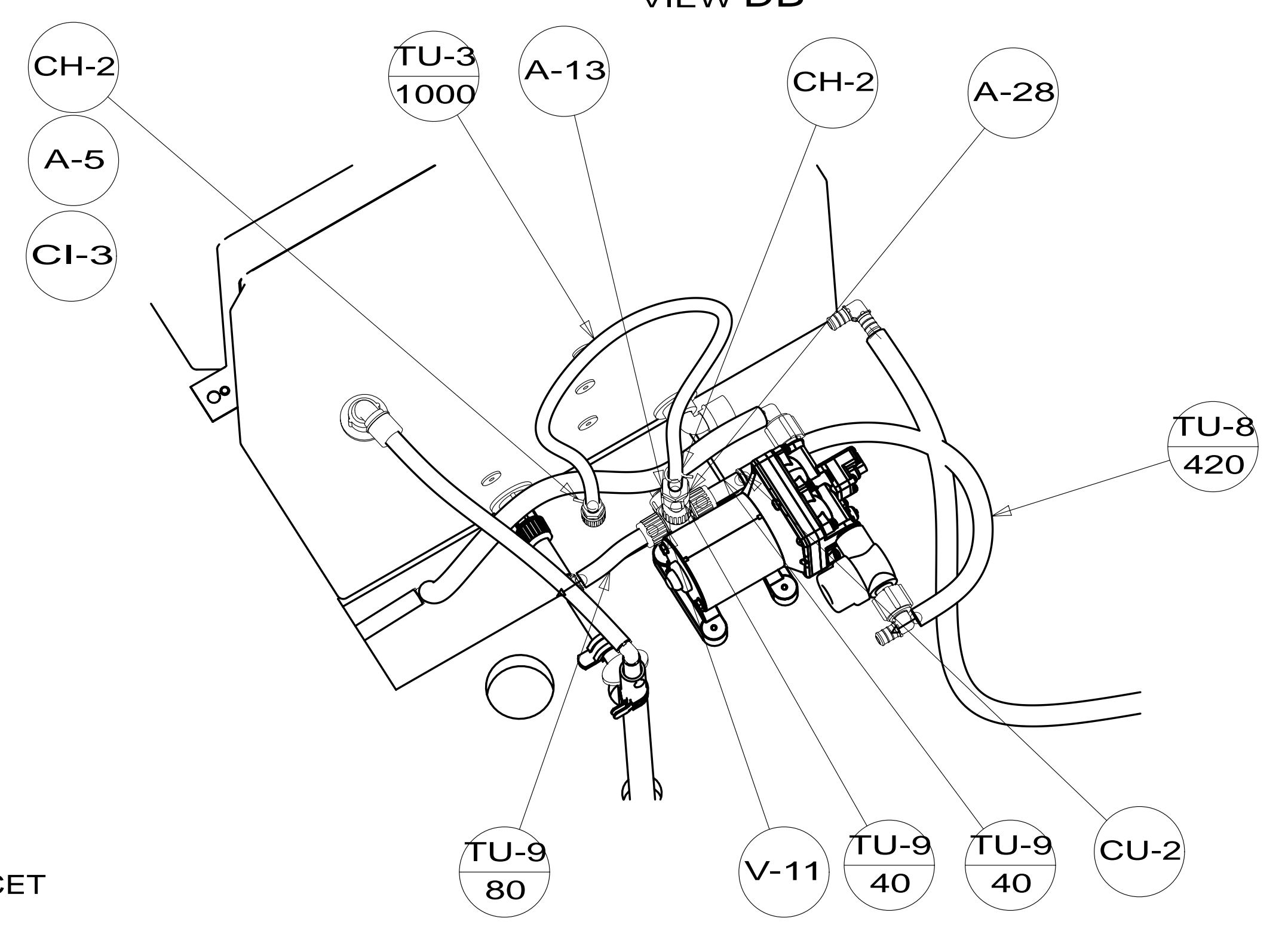
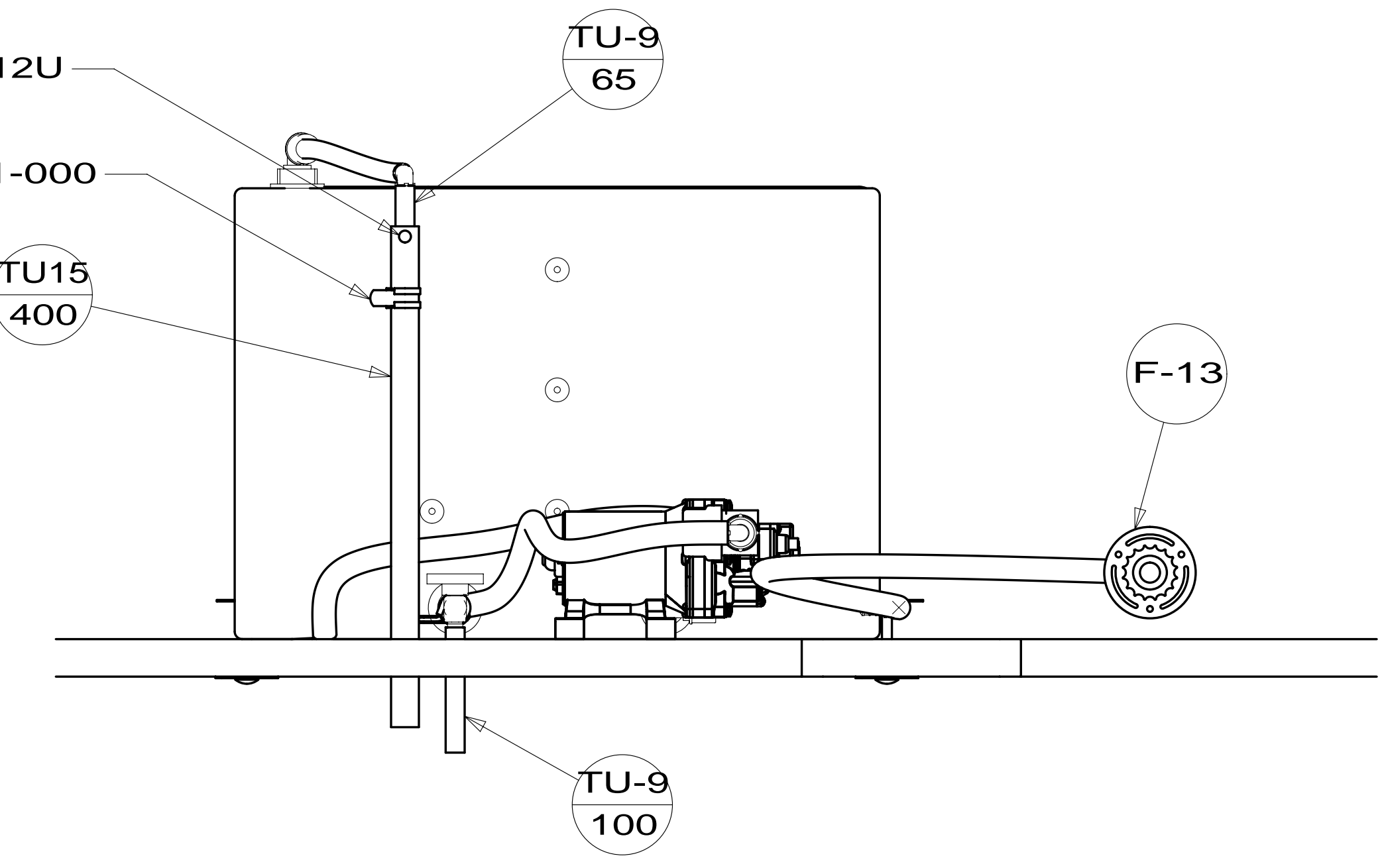
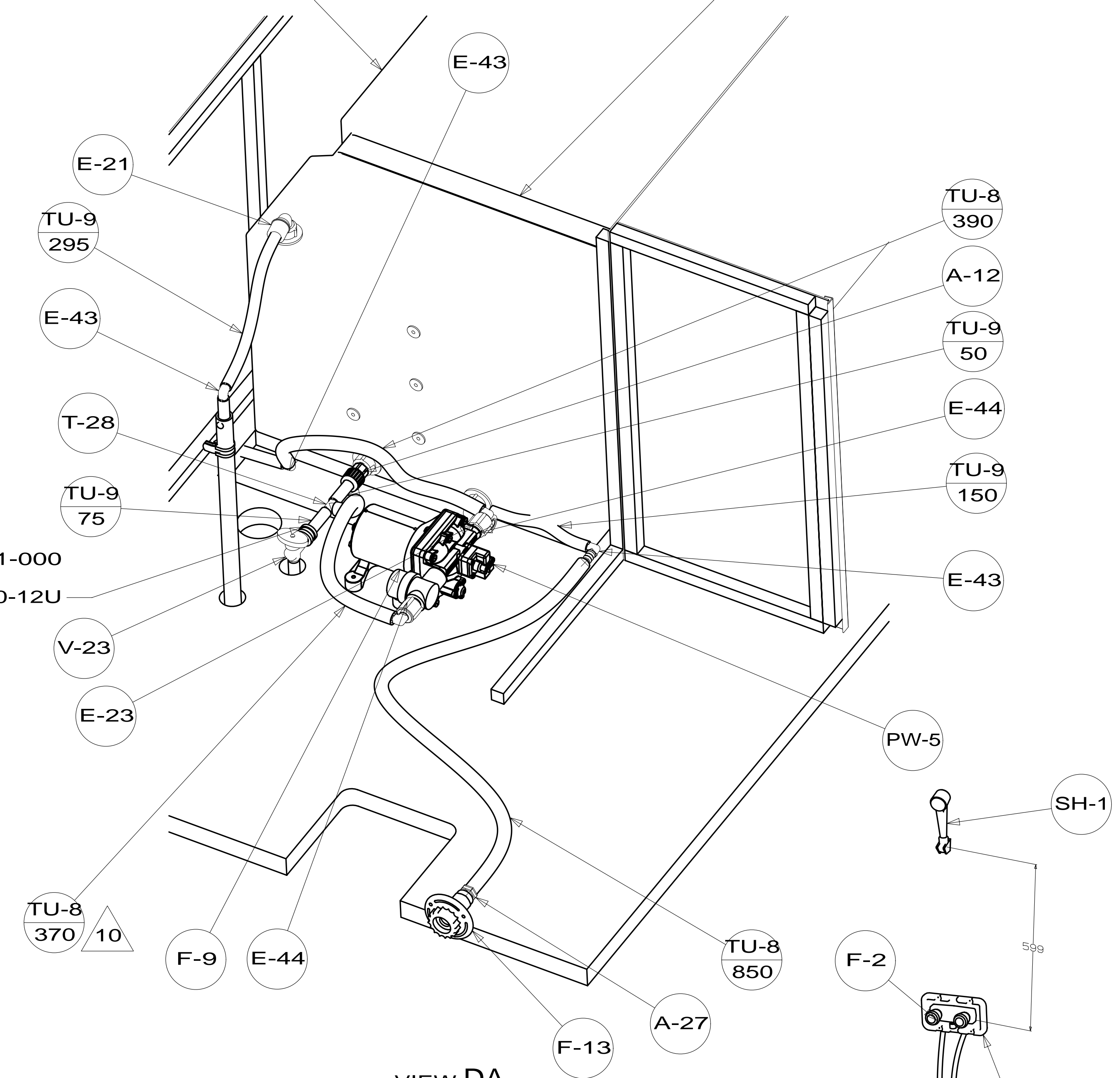

FIRST USED	14 327Q / QP	
TITLE:	DO NOT SCALE DRAWING	
SHEET	4	PART NO 186162 REV
		17-Apr-2014

* 186162 * A