

12. REMOVE CAP FROM CONNECTOR 114974-01-000, INSTALL SCREEN 191399-01-000 OVER HOLE, RE-INSTALL CAP.
11. USE CLEAR SILICONE TO SEAL THE SINK TO THE SHOWER SURROUND.
10. TRIM TO FIT.
9. ALL CRIMP FITTINGS TO 1/2" PEX TUBING REQUIRE 1/2" CLAMP 140171-03-000.
8. NIPPLE TO BE TRIMMED TO LENGTH ON INSTALL.
7. SECURE VENT PIPE WITH CLAMP 062401-02-000.
6. VENT PIPE MUST PROJECT 51 MIN AND 64 MAX ABOVE ROOF FOR PROPER FIT AND FUNCTION.
5. SEAL AROUND SHOWER WITH SILICONE.
4. SECURE DRAINAGE PIPES TO CABINET USING WIRE TIE 108046-02-000, AND SCREW 000G67-10-12U AT INTERVALS OF NOT MORE THAN 4 FEET APART.
3. ALL PIPE AND FITTINGS TO BE ASSEMBLED WITH SOLVENT 004020-01-000 (USA), 004020-02-000 (CAN)
2. SLOPE OF TRAP ARM MUST BE 6 PER 305 mm.
1. SLOPE OF HORIZONTAL PIPING TO BE MINIMUM OF 3 PER 305 mm.

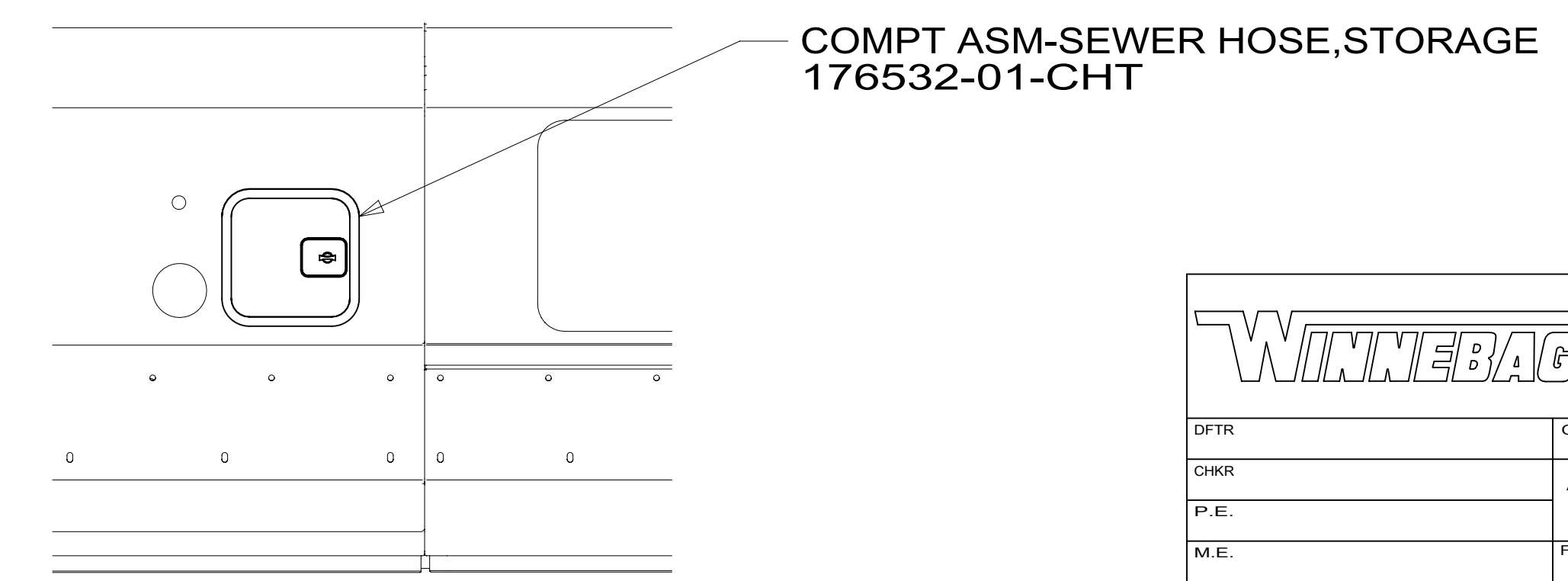
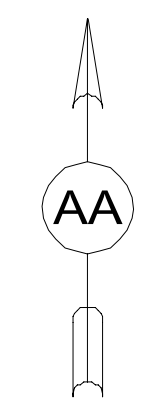

VIEW AA

FOR DRAINAGE CALLOUTS SEE DWG NO 116229-01-000

WINNEBAGO		COPYRIGHT 2014 WINNEBAGO INDUSTRIES, INC.	
DFT-ORIG	ORIG. DATE	ALL DIMENSIONS ARE IN MILLIMETERS	
CHKR		FIRST USED	
P.E.		14 259G	
M.E.		MATERIAL:	
DSNR		UNSPECIFIED TOLERANCES ARE:	
		WHOLE DIM (X) : 3	
		ONE-PLACE (X.X) : 1.5	
		TWO-PLACE (X.XX) : 0.50	
		ANGLE : 1°	
THIRD ANGLE PROJECTION		DO NOT SCALE DRAWING REFER TO ES0018 FOR FASTENER TIGHTENING GUIDELINES	
TITLE: DRAINAGE SYSTEM INSTL			
SHEET 1 OF 4	PART NO 184420	REV	
REF:	1	08-Dec-2014	

*184420 *A

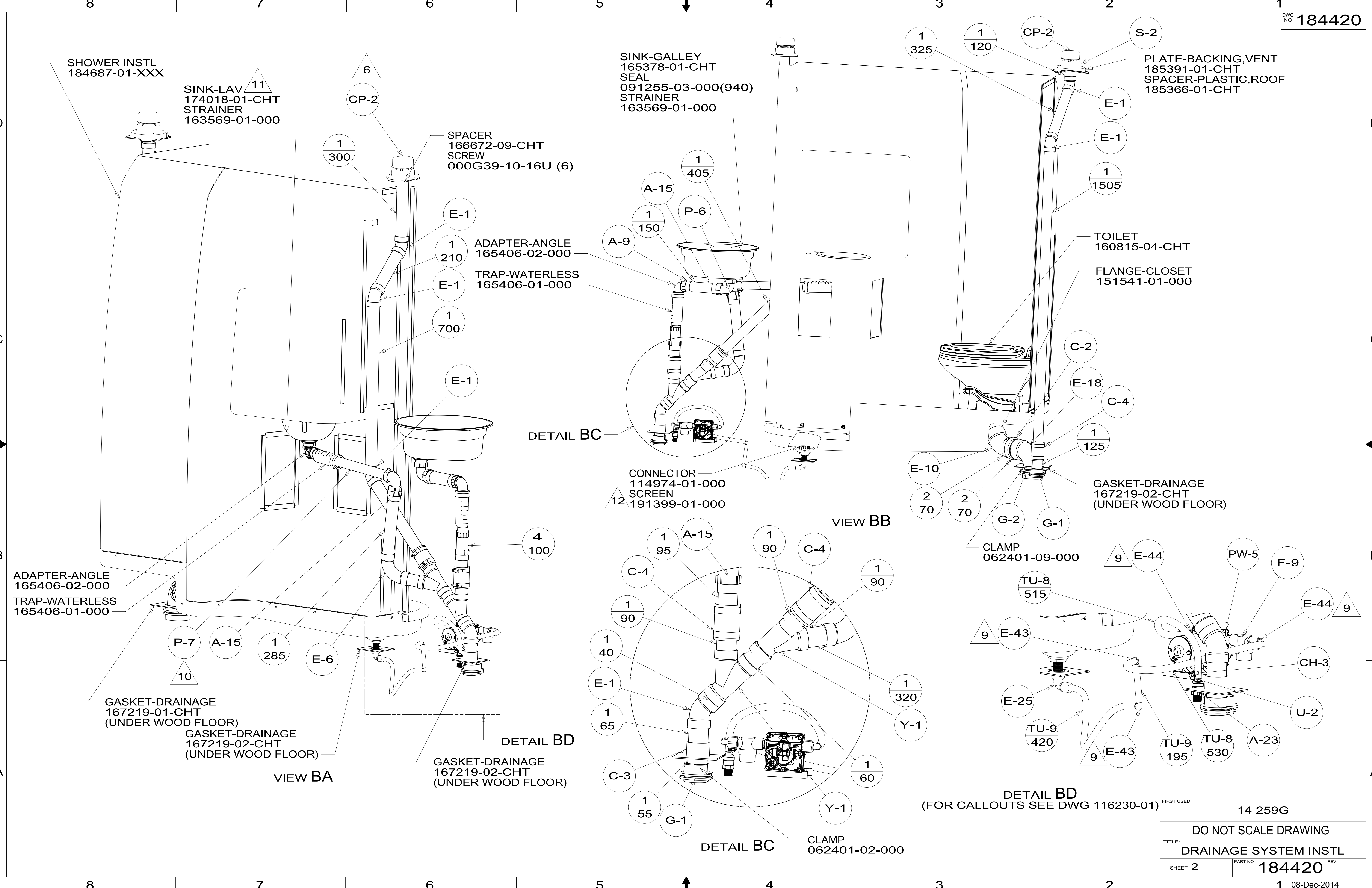

SHOWER INSTL
184687-01-XXX

SINK-LAV 11
174018-01-CHT
STRAINER
163569-01-000

SINK-GALLEY
165378-01-CHT
SEAL
091255-03-000(940)
STRAINER
163569-01-000

PLATE-BACKING, VENT
185391-01-CHT
SPACER-PLASTIC, ROOF
185366-01-CHT

ADAPTER-ANGLE
165406-02-000
TRAP-WATERLESS
165406-01-000

SPACER
166672-09-CHT
SCREW
000G39-10-16U (6)

ADAPTER-ANGLE
165406-02-000

TRAP-WATERLESS
165406-01-000

DETAIL BC

CONNECTOR
114974-01-000
SCREEN
12 191399-01-000

VIEW BB

GASKET-DRAINAGE
167219-02-CHT
(UNDER WOOD FLOOR)

GASKET-DRAINAGE
167219-01-CHT
(UNDER WOOD FLOOR)

GASKET-DRAINAGE
167219-02-CHT
(UNDER WOOD FLOOR)

VIEW BA

GASKET-DRAINAGE
167219-02-CHT
(UNDER WOOD FLOOR)

DETAIL BD

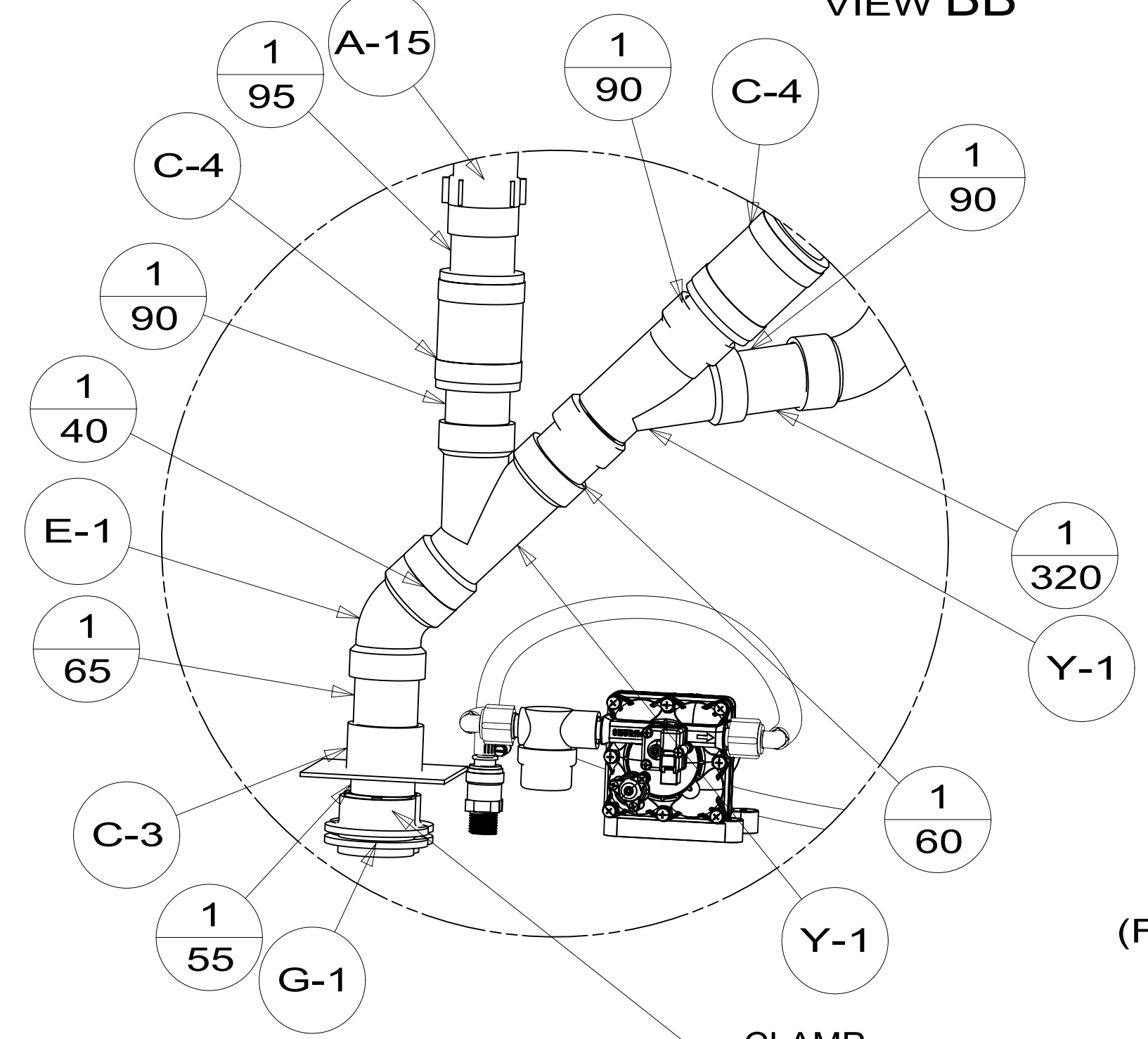

DETAIL BD
(FOR CALLOUTS SEE DWG 116230-01)

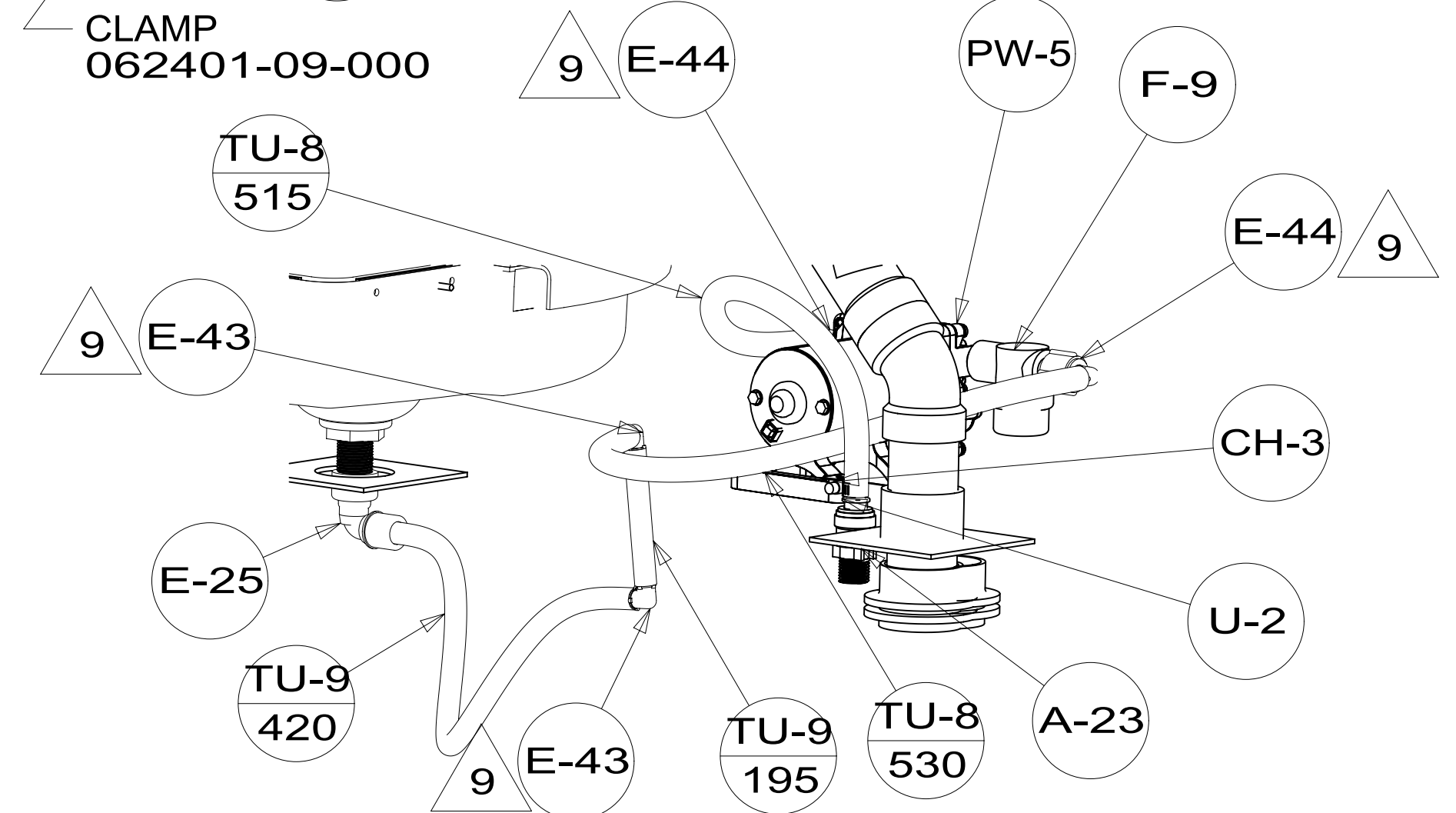

FIRST USED	14 259G
DO NOT SCALE DRAWING	
TITLE: DRAINAGE SYSTEM INSTL	
SHEET 2	PART NO 184420 REV
1 08-Dec-2014	

184420

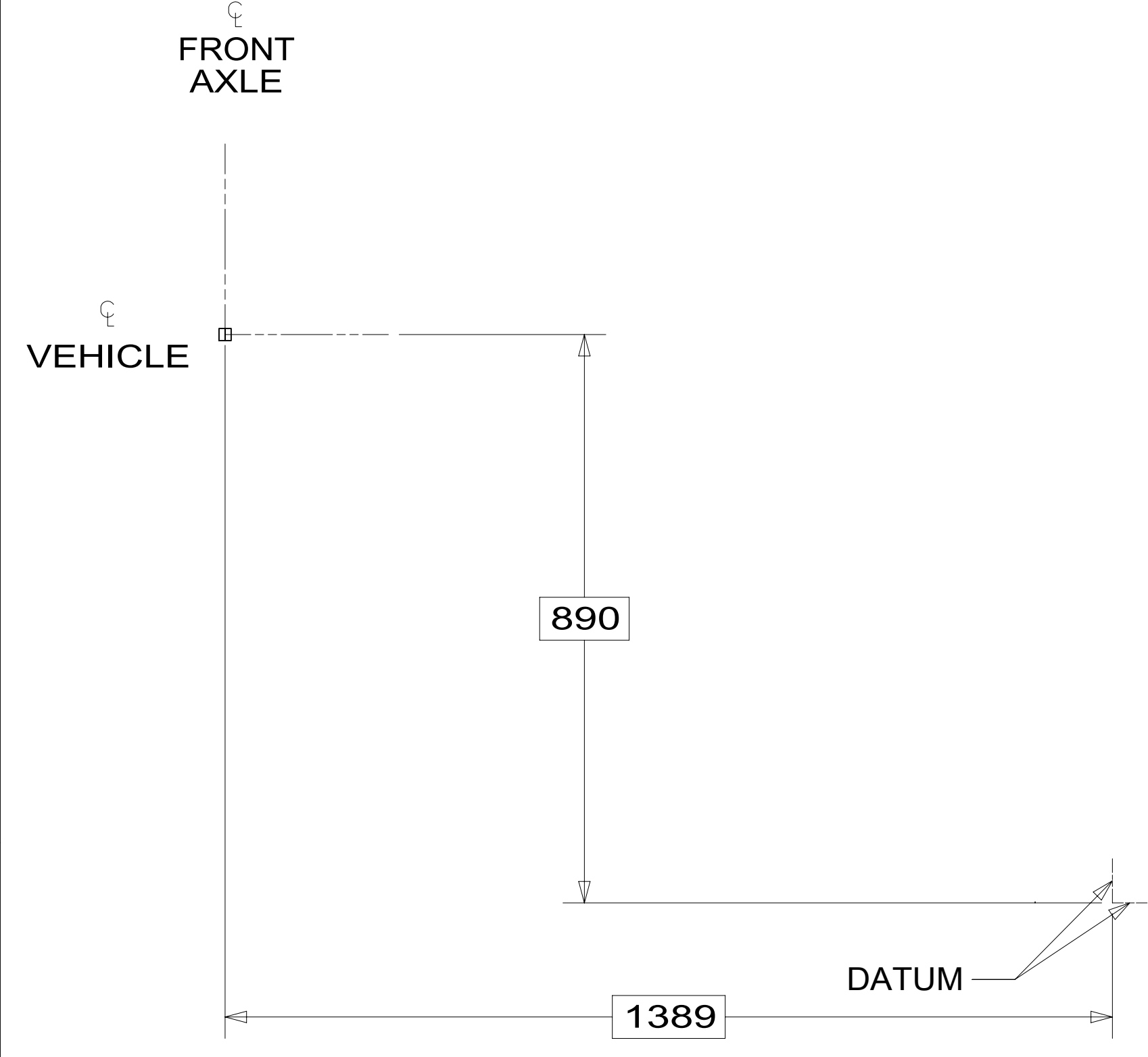
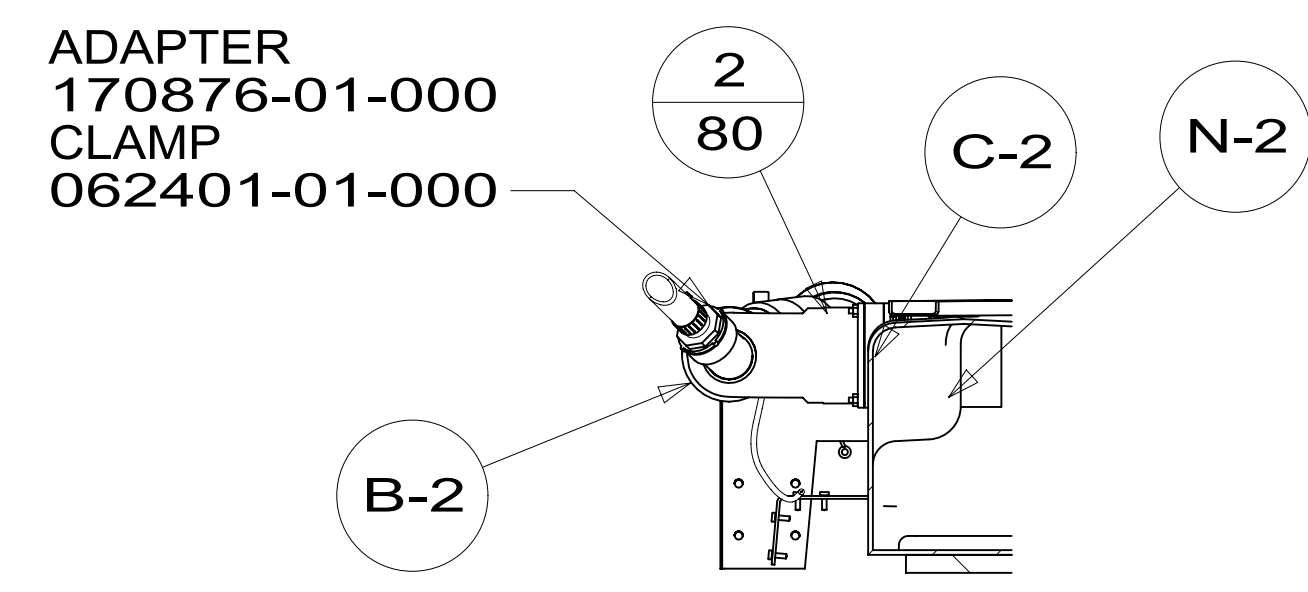

TANK ASM-HOLDING, 15 GAL
185148-02-000

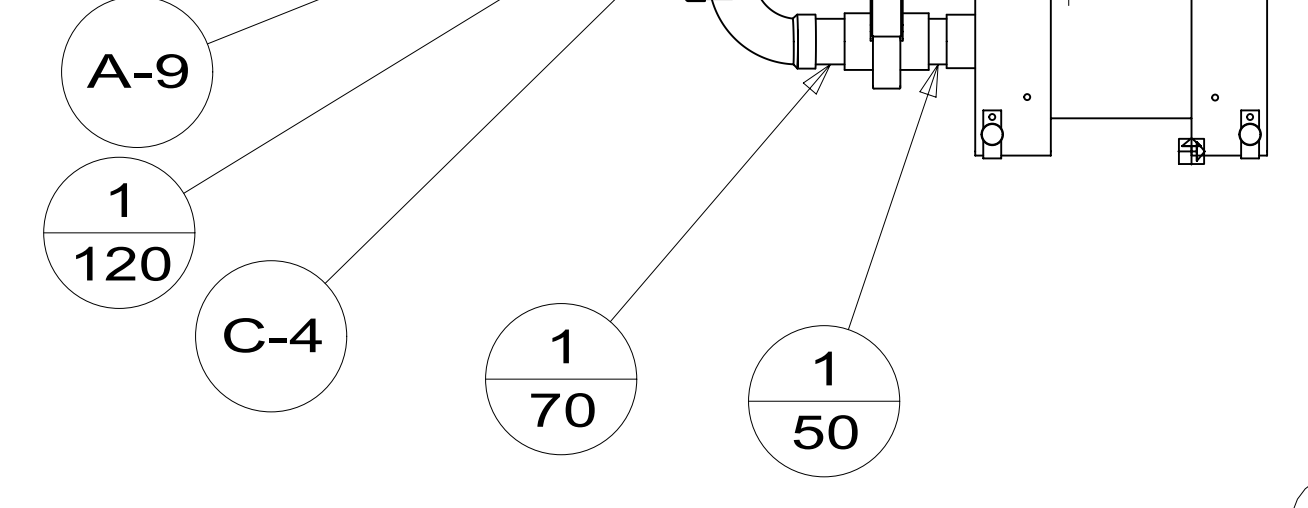

BOLT-J
091274-06-000 (3)
NUT
000D29-06-00U (3)
WASHER
000E13-18-00U (3)

U-CHANNEL
165872-09-CHT

BRACKET-HOLDING TANK
185220-03-CHT
SCREW
000G39-10-10U(8)

BRACKET-HOLDING TANK
185220-02-CHT
SCREW
000G39-10-10U(12)

FOAM
100619-16-040

TANK ASM-HOLDING, 11 GAL
185149-02-000

U-CHANNEL
165872-10-CHT

BOLT-J
091274-06-000
NUT
000D29-06-00U
WASHER
000E13-18-00U

INSULATION-DRAINAGE COMPT
181740-01-000

U-CHANNEL
165872-11-CHT

BOLT-J
091274-07-000 (3)
NUT
000D29-06-00U (3)
WASHER
000E13-18-00U (3)

ELBOW
170414-01-000

E-5

E-10

E-9

2/330

CP-1

H-1

HANDLE-EXTENSION
062419-14-000
BRACKET ASM
180888-01-CHT
GROMMET
071015-30-000

ANGLE-W/HOLE
156309-06-CHT (3)
SCREW
000G39-10-10U (12)

BRACKET-HOLDING TANK
185220-01-CHT
SCREW
000G39-10-10U(12)

PANEL-SERVICE CENTER
185342-01-CHT
SCREW
000G39-10-10U(12)

BOLT-J
091274-07-000 (3)
NUT
000D29-06-00U (3)
WASHER
000E13-18-00U (3)

ANGLE-W/HOLE
156309-06-CHT (3)
SCREW
000G39-10-10U(12)

ANGLE-SUPPORT
168448-03-CHT

VALVE
062421-03-000

SUPPORT ASM-PUMP,MACERATOR
185382-01-CHT
PLATE-W/HOLES
165825-02-CHT (4)
NUT
000D39-06-00U (4)

BRACKET-PUMP,MACERATOR
185379-01-CHT
PUMP-MACERATOR
165762-02-000
PLUG-PLASTIC
061420-03-000
SCREW
000G19-10-20U(4)
WASHER
000E14-10-00U(4)
NUT
000D28-10-00U(4)

HOSE
191977-01-000
(2400)
CONDUIT
173083-02-900
(WIRE TIE MACERATOR PUMP
HOSE UP TO THE CHASSIS
FRAME ASM)

VALVE
062421-13-000

2/75

A-4

U-CHANNEL
165872-12-CHT

U-CHANNEL
165872-09-CHT

CLAMP
083610-02-000

E-3

A-12

VIEW CA

FIRST USED	14 259G
DO NOT SCALE DRAWING	
TITLE: DRAINAGE SYSTEM INSTL	
SHEET 3	PART NO 184420 REV
1 08-Dec-2014	

184420

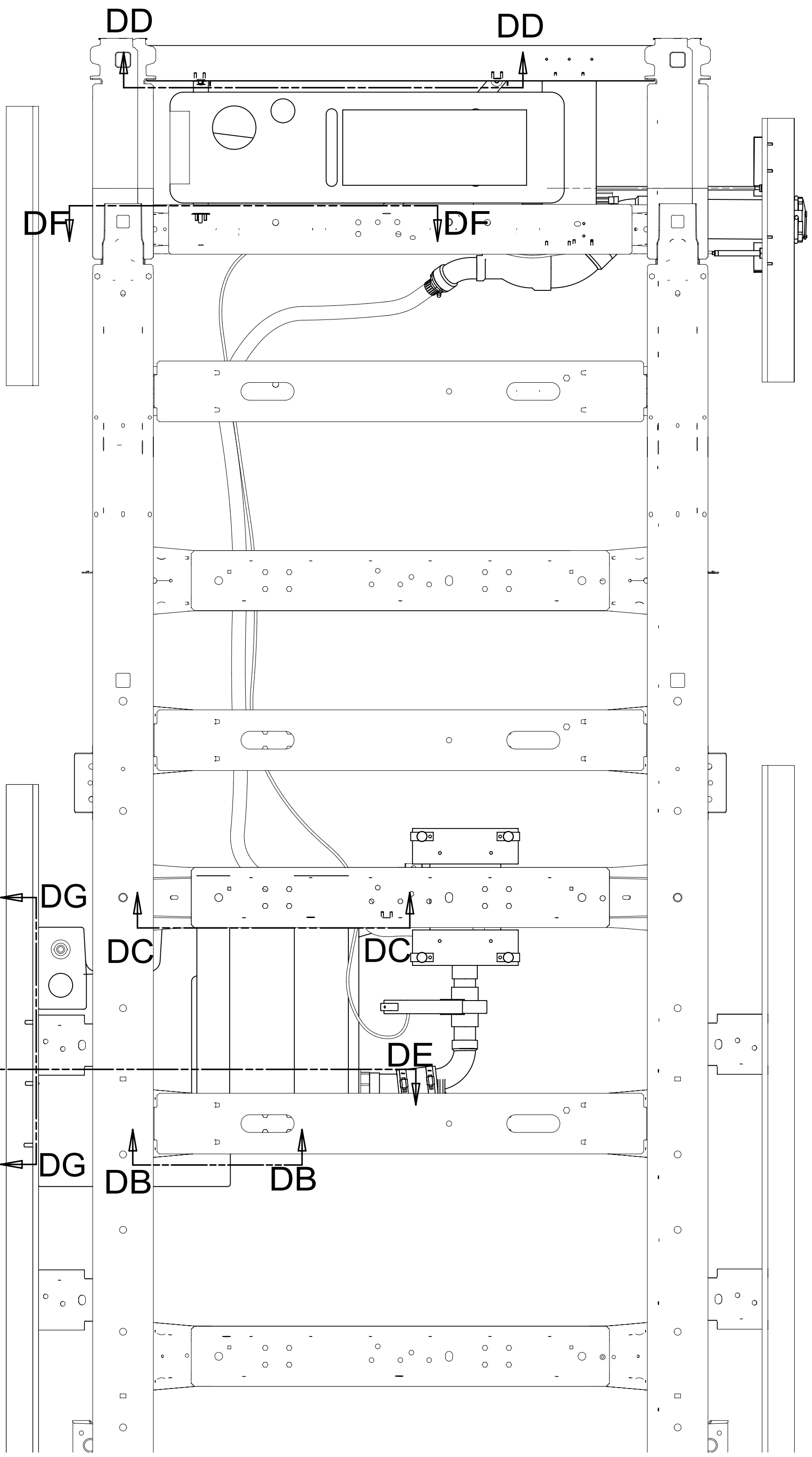

VIEW DA

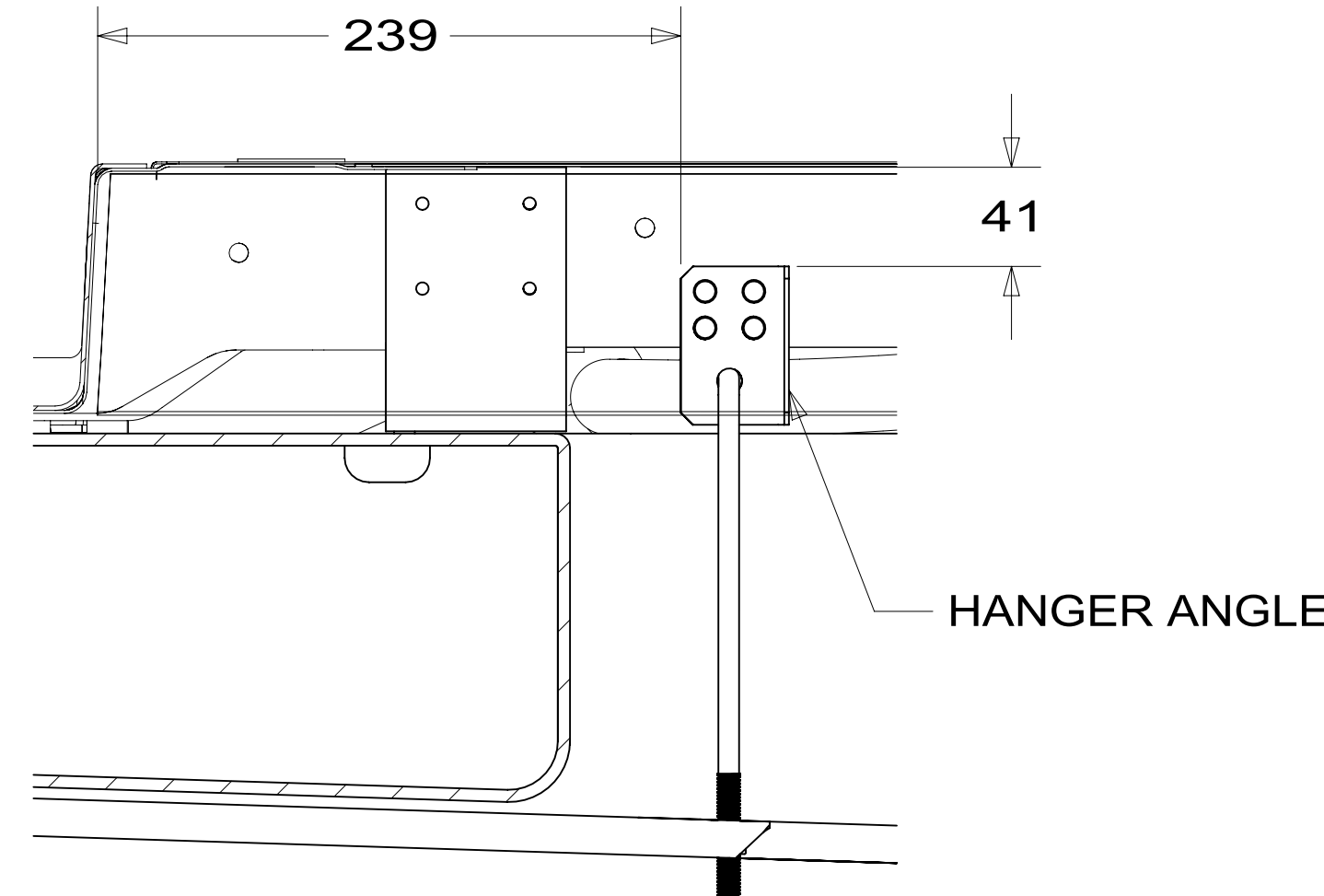

SECTION DB-DB

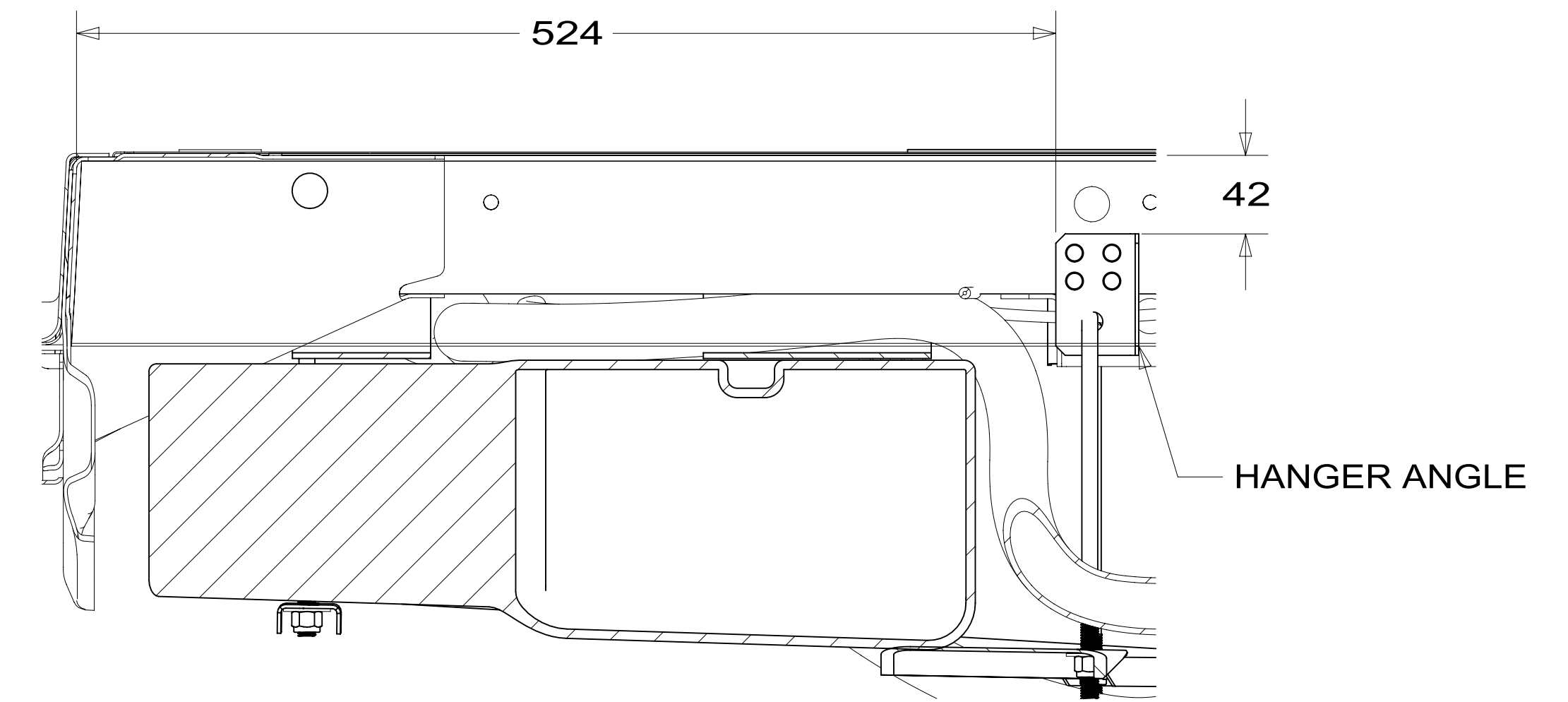

SECTION DC-DC

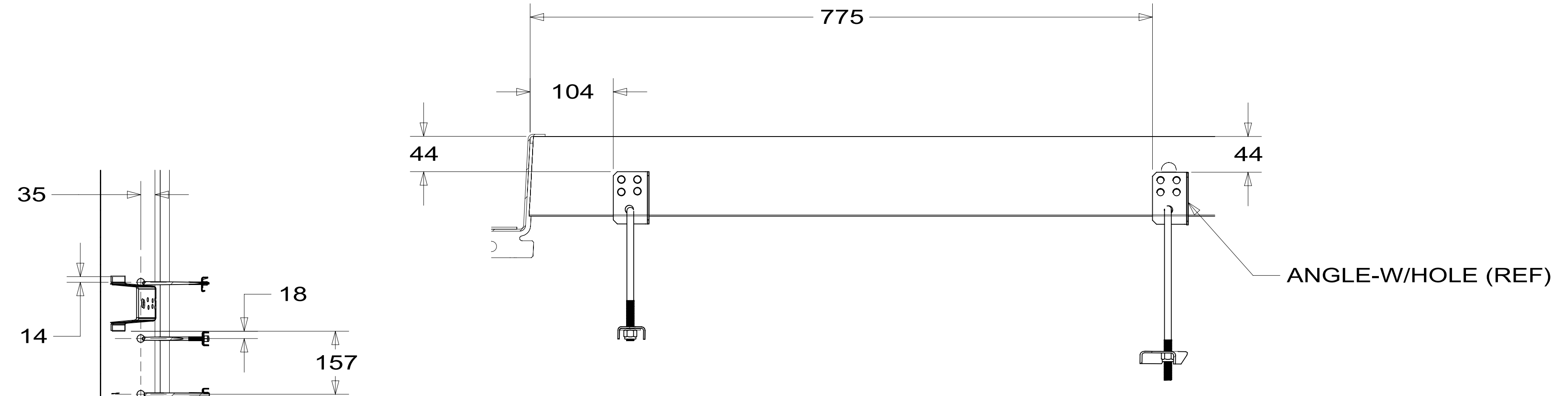

SECTION DD-DD

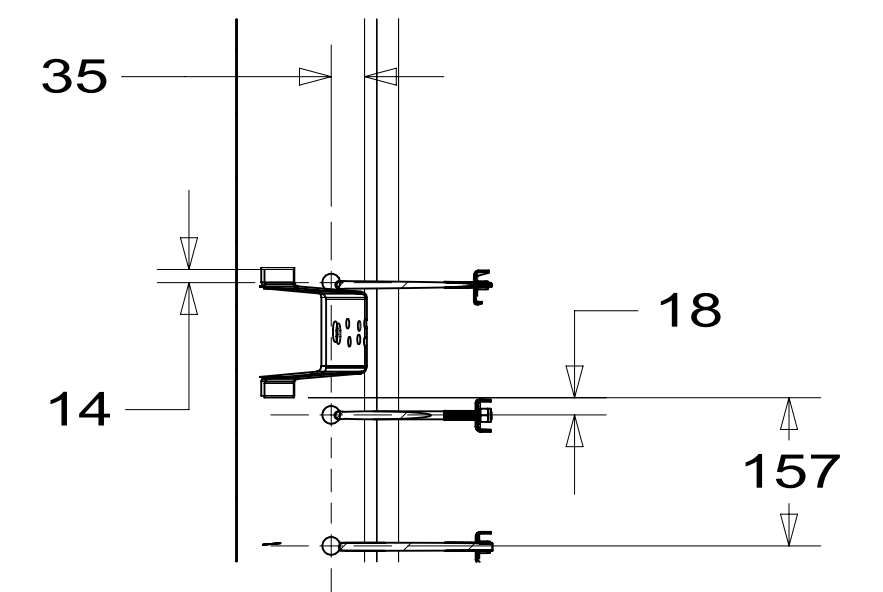

SECTION DG-DG

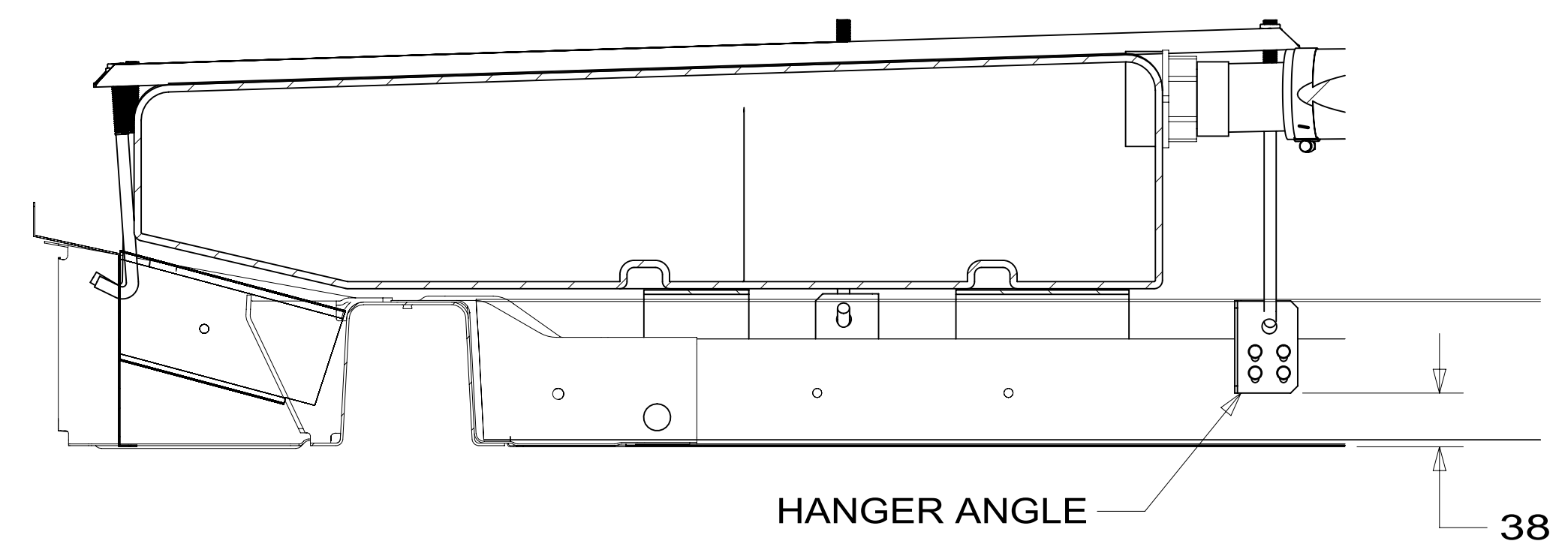

SECTION DE-DE

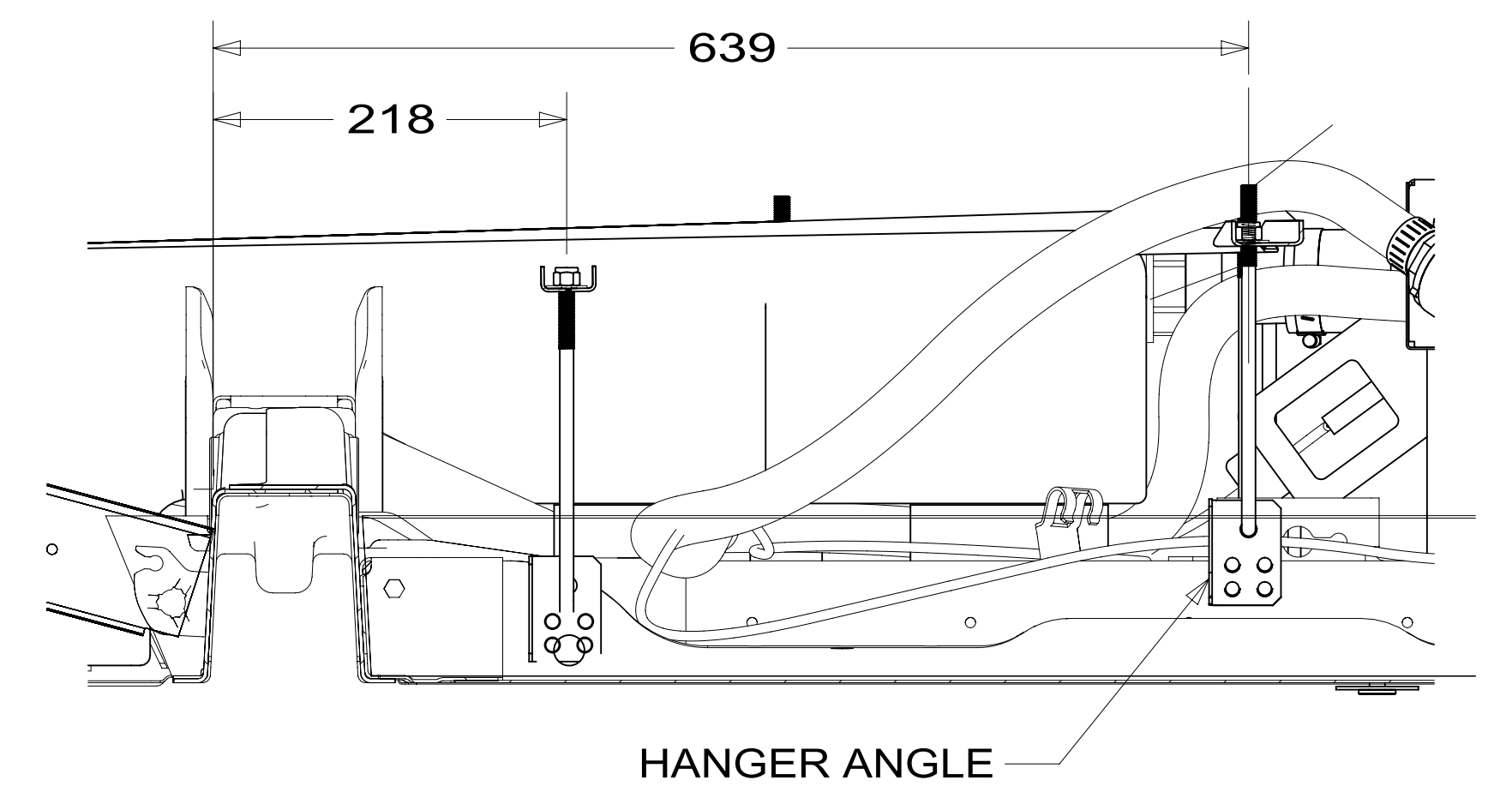

SECTION DF-DF

FIRST USED	14 259G	
TITLE:	DO NOT SCALE DRAWING	
SHEET	4	PART NO 184420 REV
1 08-Dec-2014		

*184420 *A

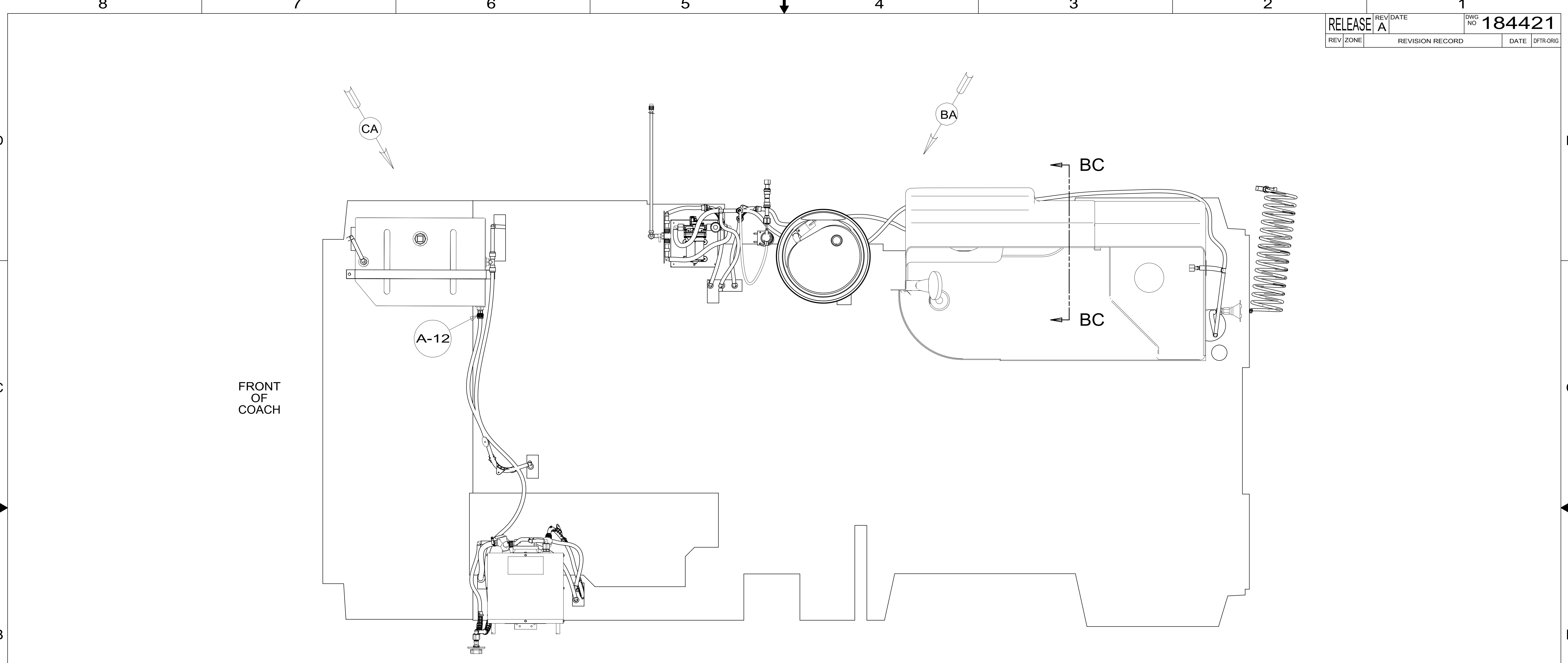

29B WATER PURIFIER

- NOTES:
9. PARTS TO BE ASSEMBLED AND ABLE TO BE REMOVED AND STORED AS A SINGLE ASM.
 8. ALL CRIMP FITTINGS TO 1/2" PEX TUBING REQUIRE 1/2" CLAMP 140171-03-000.
 7. ALL CRIMP FITTINGS TO 5/8" PEX TUBING REQUIRE 5/8" CLAMP 140171-04-000.
 6. LABEL HOT AND COLD SUPPLY TUBES AND TAPE FITTING TO TUBE BEFORE CABINET SET TO PREVENT MOVEMENT.
 5. ADD PIPE WRAP (LADDER SCRAP 110157-02-000) INSULATION.
 4. ADD TEFLON TAPE 010405-02-000.
 3. ALL TUBING TO BE SECURED AT 1200 INTERVALS MAXIMUM WITH CLAMP 010495-01-000 AND SCREW 000G67-10-12B OR EQUIVALENT.
 2. TUBING TO BE INSTALLED WITH SUFFICIENT SLOPE TO PROVIDE DRAINAGE TO NEAREST VALVE.
 1. PLASTIC FITTINGS TO BE SEALED WITH SEALANT 084456-01-000.

FOR WATER CALLOUTS SEE DWG NO 116230-01-000

WINNEBAGO		COPYRIGHT 2014 WINNEBAGO INDUSTRIES, INC.	
DFTR	ORIG. DATE	ALL DIMENSIONS ARE IN MILLIMETERS	
CHKR			
P.E.			
M.E.	FIRST USED		
DSNR		14 259G	
UNSPECIFIED TOLERANCES ARE:		MATERIAL:	
WHOLE DIM (X)	: 3		
ONE-PLACE (X.X)	: 1.5		
TWO-PLACE (X.XX)	: 0.50		
ANGLE	: 1°		
THIRD ANGLE PROJECTION			
DO NOT SCALE DRAWING		REFER TO ES0018 FOR FASTENER TIGHTENING GUIDELINES	
TITLE: WATER SYSTEM INSTL			
SHEET 1 OF 3	PART NO 184421	REV	
REF:	1	26-Feb-2015	

*184421 *A

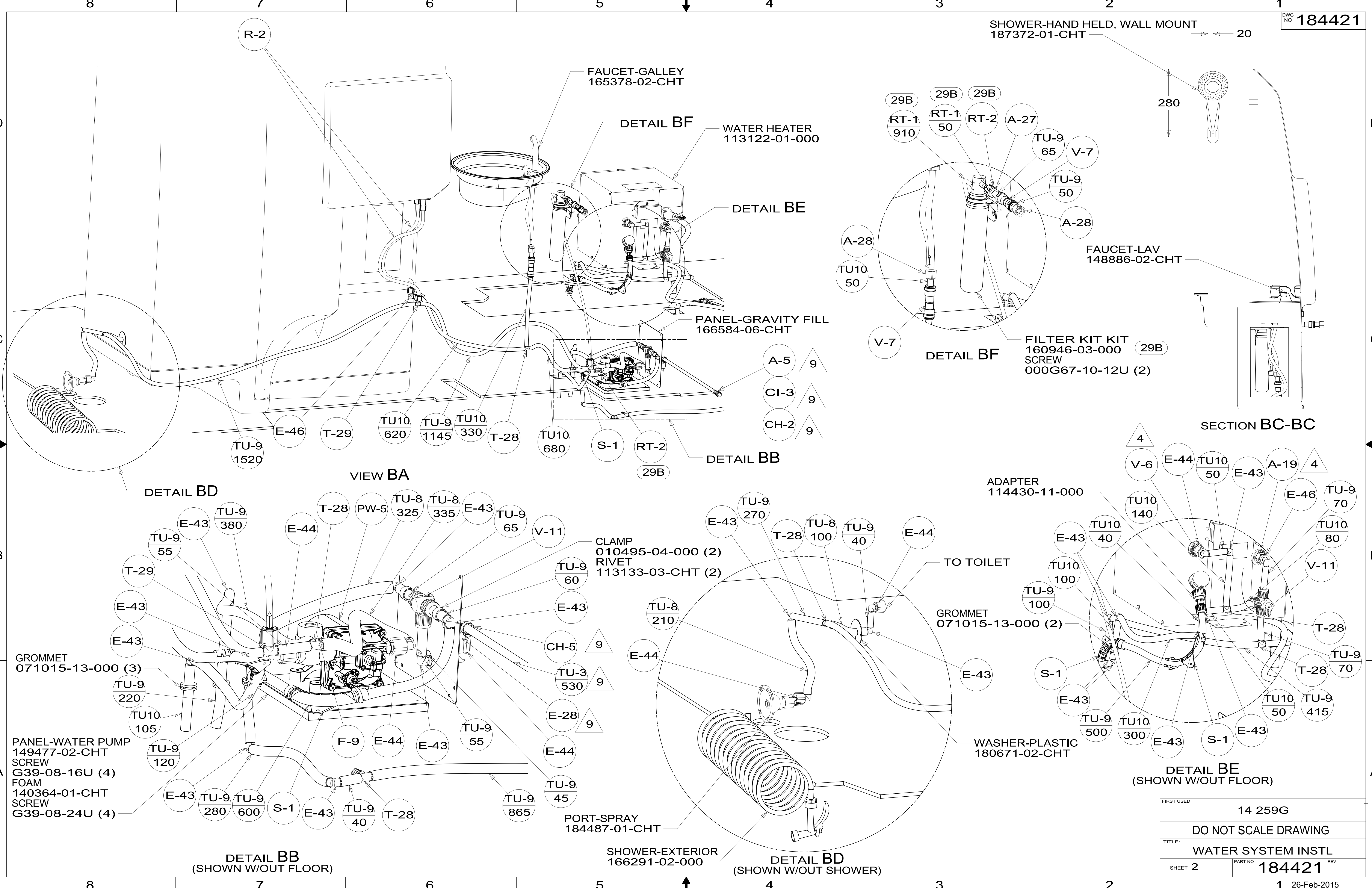

D
C
B
A

D
C
B
A

8 7 6 5 4 3 2 1

8
7
6
5
4
3
2
1

FIRST USED	14 259G
DO NOT SCALE DRAWING	
TITLE: WATER SYSTEM INSTL	
SHEET 2	PART NO 184421 REV
1 26-Feb-2015	

184421

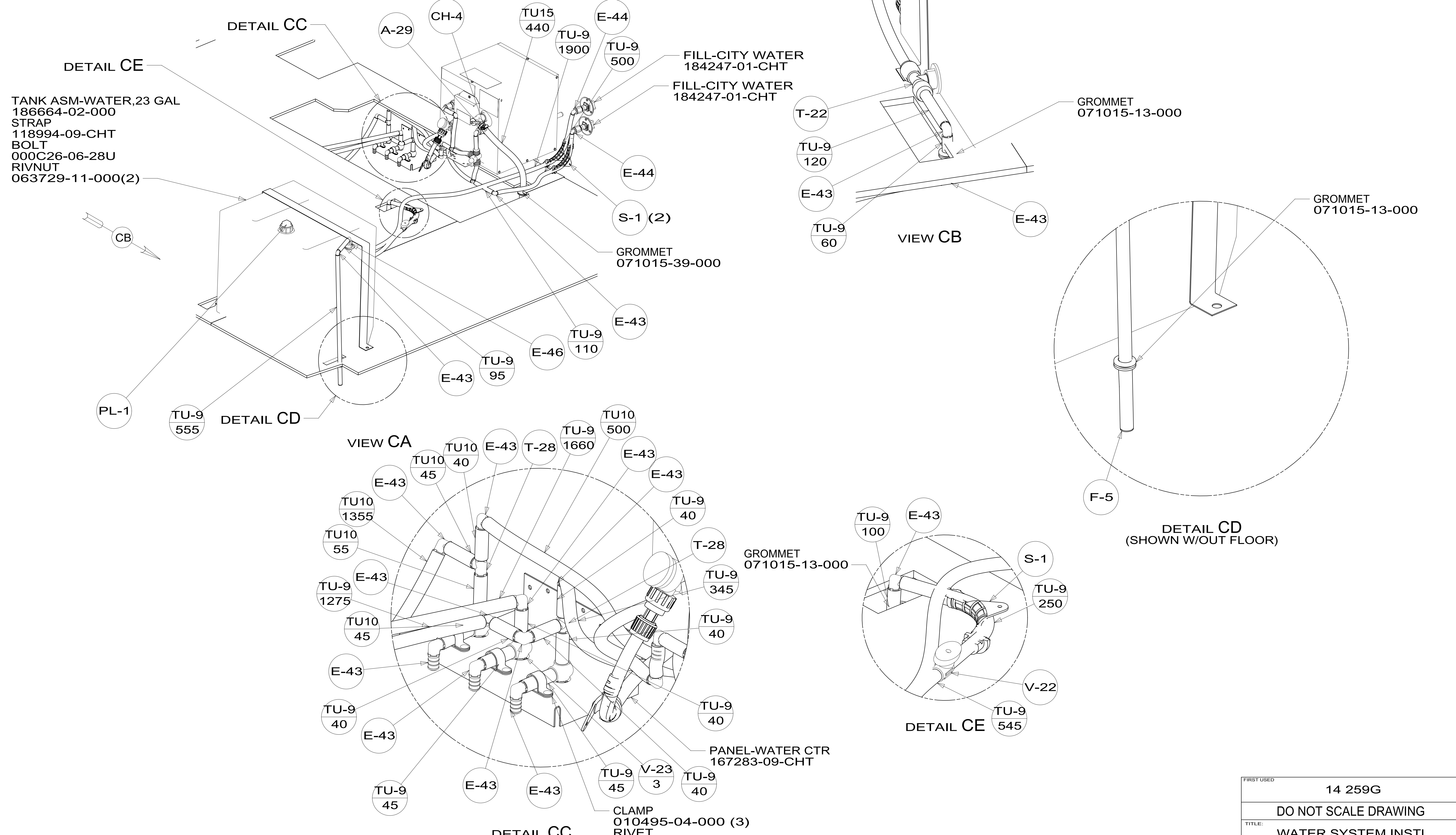

FIRST USED	14 259G	
TITLE:	DO NOT SCALE DRAWING	
SHEET 3	PART NO	184421
	REV	1
26-Feb-2015		

184421