



DANGER

Danger of electrical shock, burns or death. Always remove all power sources before attempting any repair, service or diagnostic work. Power can be present from shore power, generator, inverter or battery. All power sources must be disabled and secured before performing any service.



CAUTION

If you lack the skills, tools or equipment to perform diagnostic or repair work leave such work to an authorized Winnebago Industries dealer or other qualified shop.

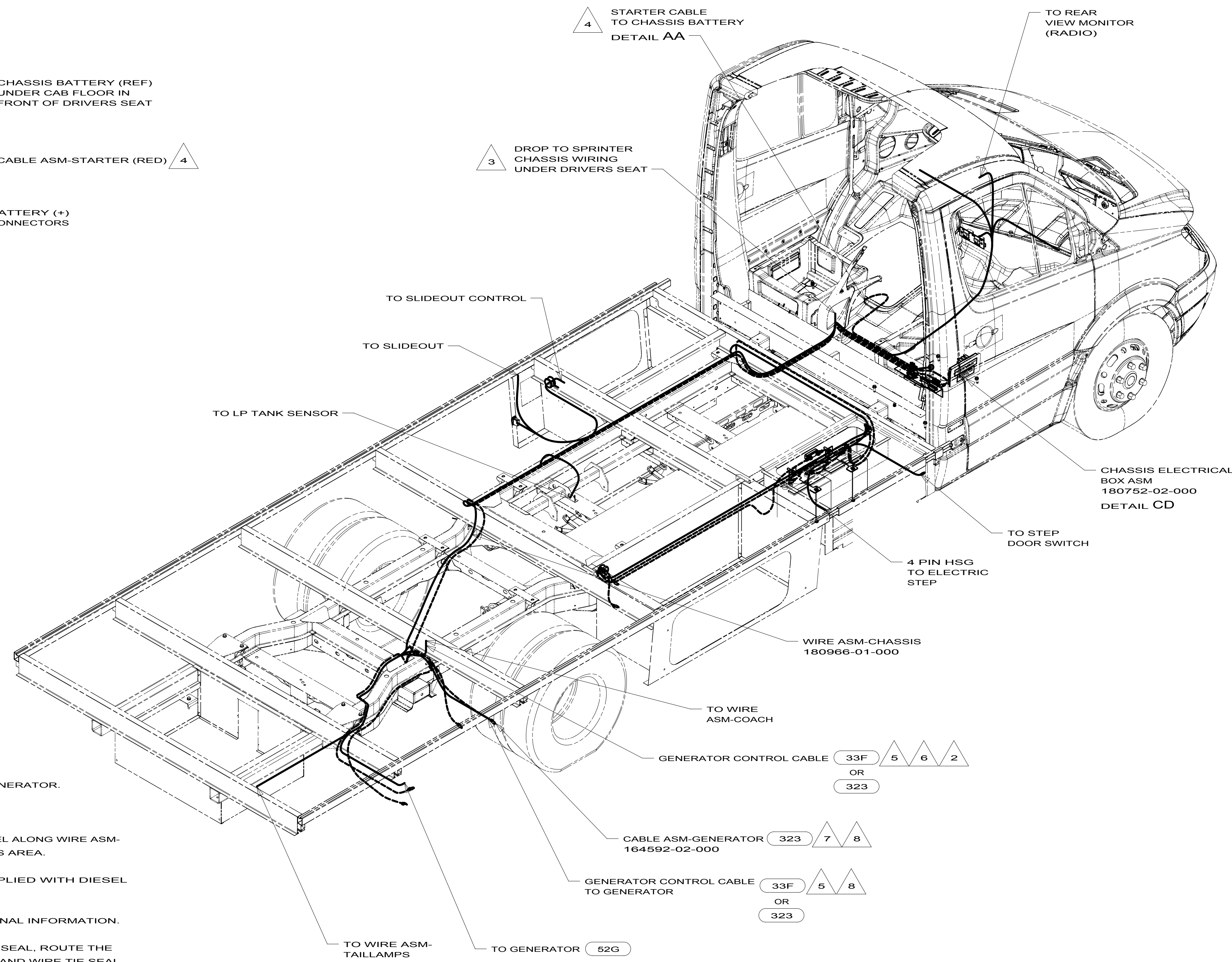
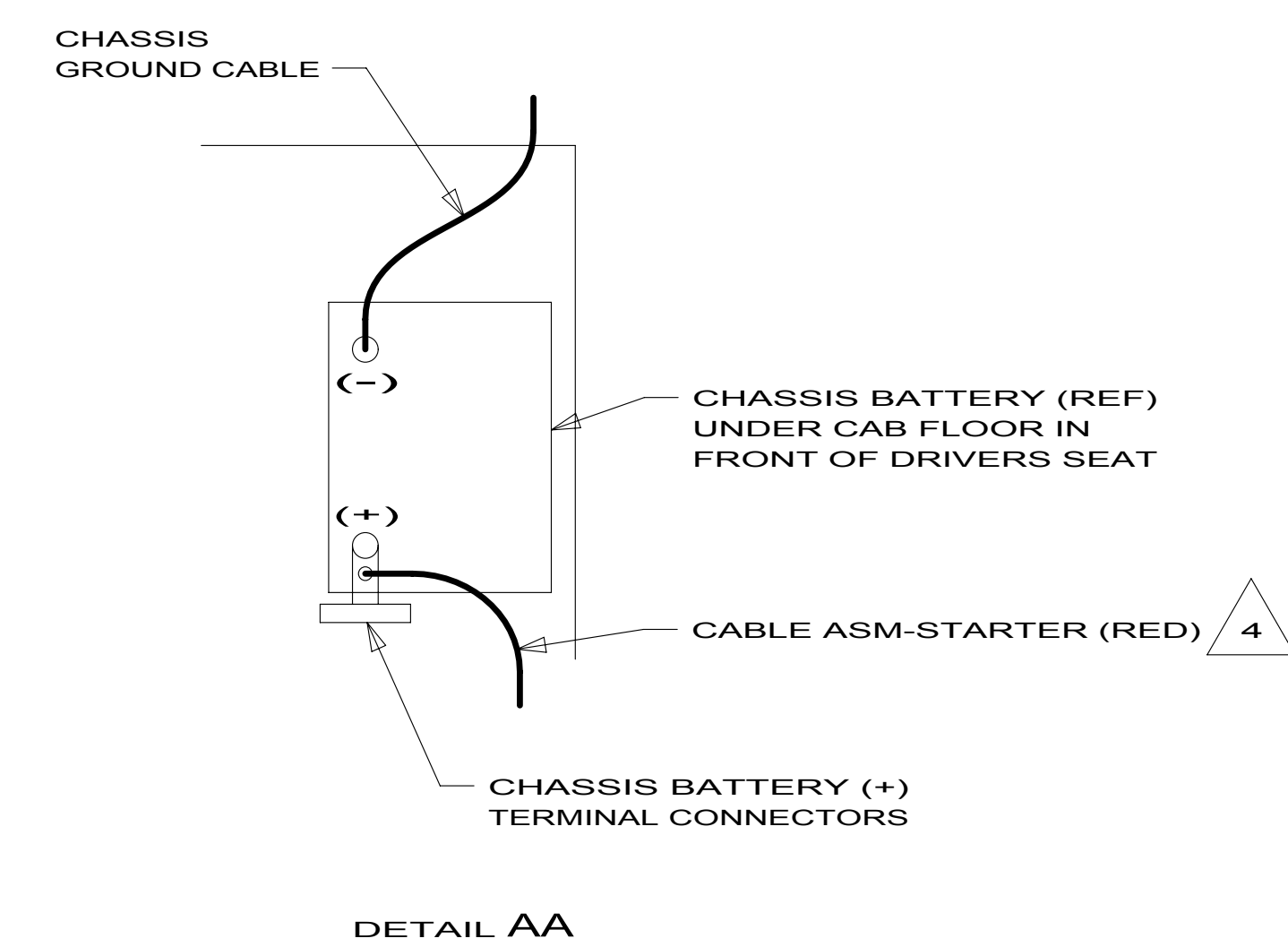

- 8 10-PIN HOUSING CONNECTS TO GENERATOR.
- 7 NOT USED WITH 33F
- 6 ROUTE GENERATOR CONTROL CABEL ALONG WIRE ASM-CHASSIS THROUGH FLOOR IN THIS AREA.
- 5 WITH FEATURE 33F CABLE SUPPLIED WITH DIESEL GENERATOR.
- 4 SEE BATTERY INSTL FOR ADDITIONAL INFORMATION.
- 3 CUT WIRE TIE AROUND SPRINTER SEAL, ROUTE THE CHASSIS WIRING THROUGH HOLE AND WIRE TIE SEAL WITH WIRE TIE 8343-04-000.
- 2 12-PIN HOUSING TO BE ROUTED ABOVE FLOOR TO CONTROL PANEL.

NOTES:

1. SECURE CONDUIT 41953, TAB AS REQUIRED, OVER ALL WIRES IN CONTACT WITH SHARP EDGES.

- 52G GEN-3.6KW ONAN LP MICROQUIET
- 33F GEN-3.5 KW ONAN DIESEL
- 323 GENERATOR PREP KIT - DIESEL
- 1MD MERCEDES-11,030# GVWR,DIESEL
- 265 CODES/STANDARDS-CSA/CMVSS
- 1B1 CODES/STANDARDS USA

WINNEBAGO INDUSTRIES		COPYRIGHT 2011 WINNEBAGO INDUSTRIES, INC.	
DTR	ORIG. DATE	13 524V	
CHKR			
P.E.	ALL DIMENSIONS ARE IN MILLIMETERS		
M.E.	FIRST USED		
DSNR			
UNSPECIFIED TOLERANCES ARE:		MATERIAL:	
WHOLE DIM (X)	: 3		
ONE-PLACE (X.X)	: 1.5		
TWO-PLACE (X.XX)	: 0.50		
ANGLE	: 1°		
THIRD ANGLE PROJECTION			
DO NOT SCALE DRAWING		REFER TO ES0018 FOR FASTENER TIGHTENING GUIDELINES	
TITLE: WIRING INSTL-CHASSIS			
SHEET 1 OF 3	PART NO	180586	REV
REF:	1		1/19/2012

FOR ELECTRICAL TORQUE SPECIFICATIONS SEE DWG NO. 128783-01-000

FOR ELECTRICAL CALLOUTS SEE DWG NO. 121339-01-000

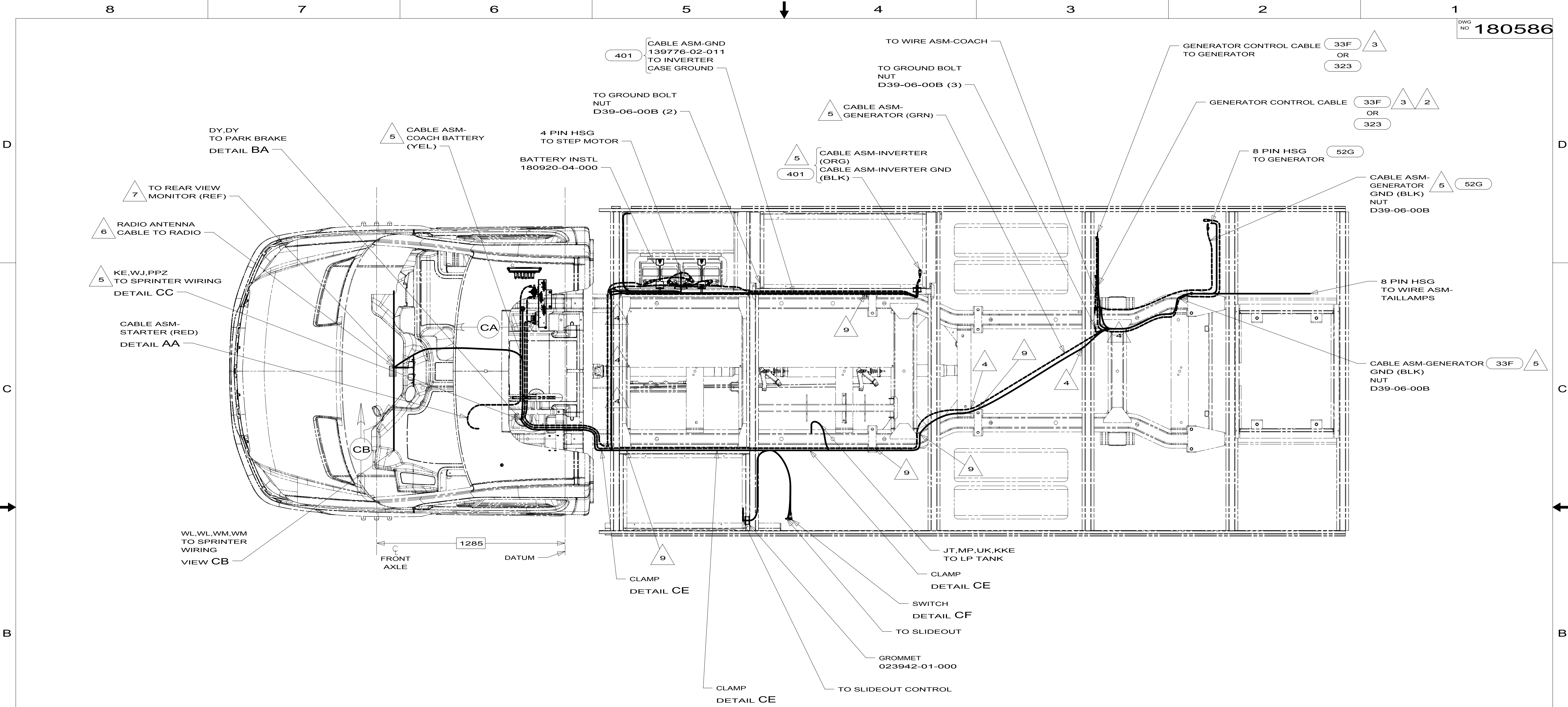

- 9 TIE-WIRE MOUNT 116673-01-000. USE HOLES IN BODY MOUNTS.
- 8 CUT BROWN/BLACK WIRE FROM PARK BRAKE SWITCH AND RECONNECT TO CIRCUIT DY OF WIRE ASM-CHASSIS AS SHOWN.
- 7 SEE RADIO/MONITOR INSTL FOR ADDITIONAL INFORMATION.
- 6 ROUTE WIRES THROUGH CAB FLOOR UNDER DRIVERS SEAT PEDESTAL.
- 5 SEE BATTERY INSTL FOR ADDITIONAL INFORMATION.
- 4 CLAMP 83610-02-000, SCREW G39-08-12B. DO NOT DRILL OR SCREW INTO SPRINTER FRAME. USE ALUMINUM RISERS.
- 3 WITH FEATURE 33FCABLE SUPPLIED WITH DIESEL GENERATOR.
- 2 ROUTE GENERATOR CONTROL CABLE ALONG WIRE ASM-CHASSIS THROUGH FLOOR IN THIS AREA.

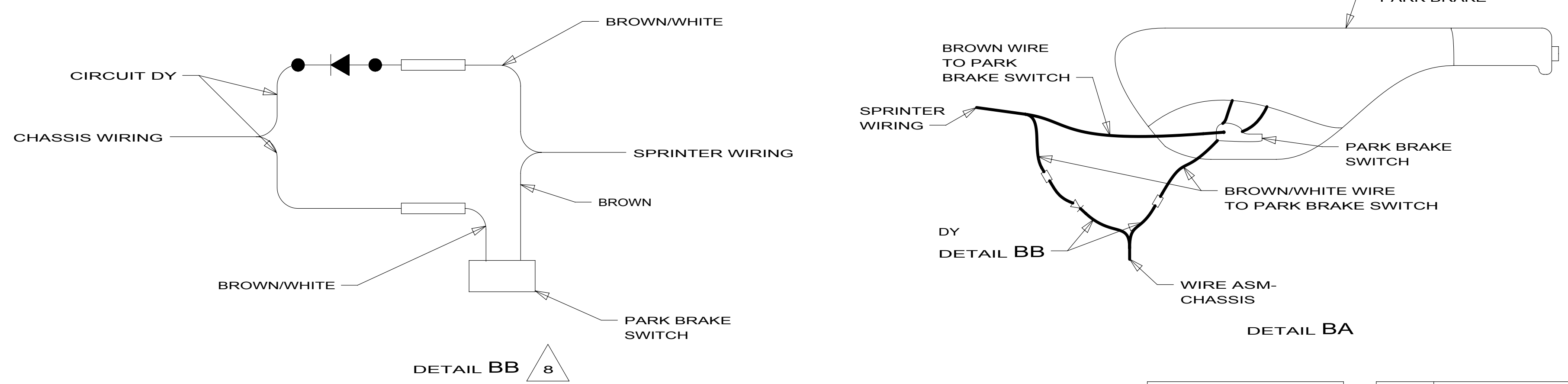

- 401 INVERTER-DC/AC, 1000 WATT
- 52G GEN-3.6KW ONAN LP MICROQUIET
- 33F GEN-3.5 KW ONAN DIESEL
- 323 GENERATOR PREP KIT - DIESEL
- 1MD MERCEDES-11,030# GVWR,DIESEL
- 265 CODES/STANDARDS-CSA/CMVSS
- 1B1 CODES/STANDARDS USA

NOTES:
 1. SECURE CONDUIT 41953, TAB AS REQUIRED, OVER ALL WIRES IN CONTACT WITH SHARP EDGES.

FOR ELECTRICAL TORQUE SPECIFICATIONS SEE DWG NO. 128783-01-000

X-X FOR ELECTRICAL CALLOUTS SEE DWG NO. 121339-01-000

FIRST USED

13 524V

DO NOT SCALE DRAWING

TITLE: **WIRING INSTL-CHASSIS**

SHEET 2 PART NO. **180586** REV

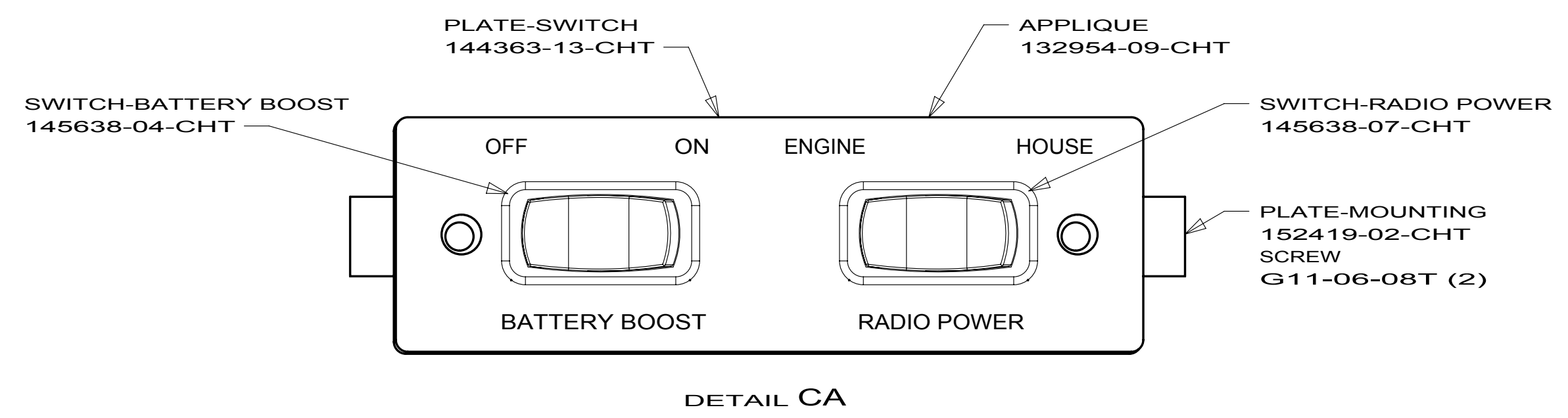

DETAIL CA

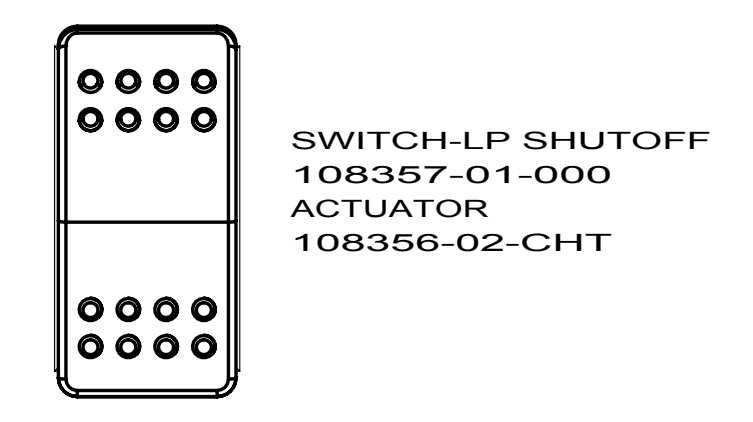

DETAIL CF

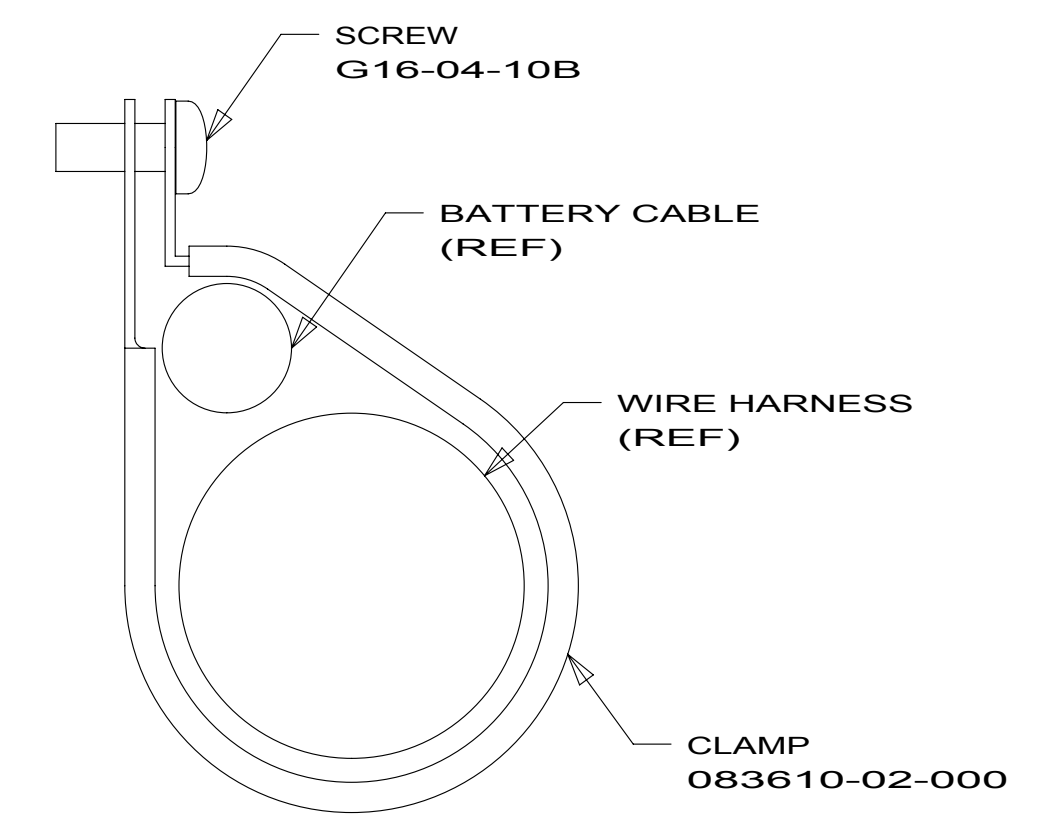

DETAIL CE (4 PLACES)

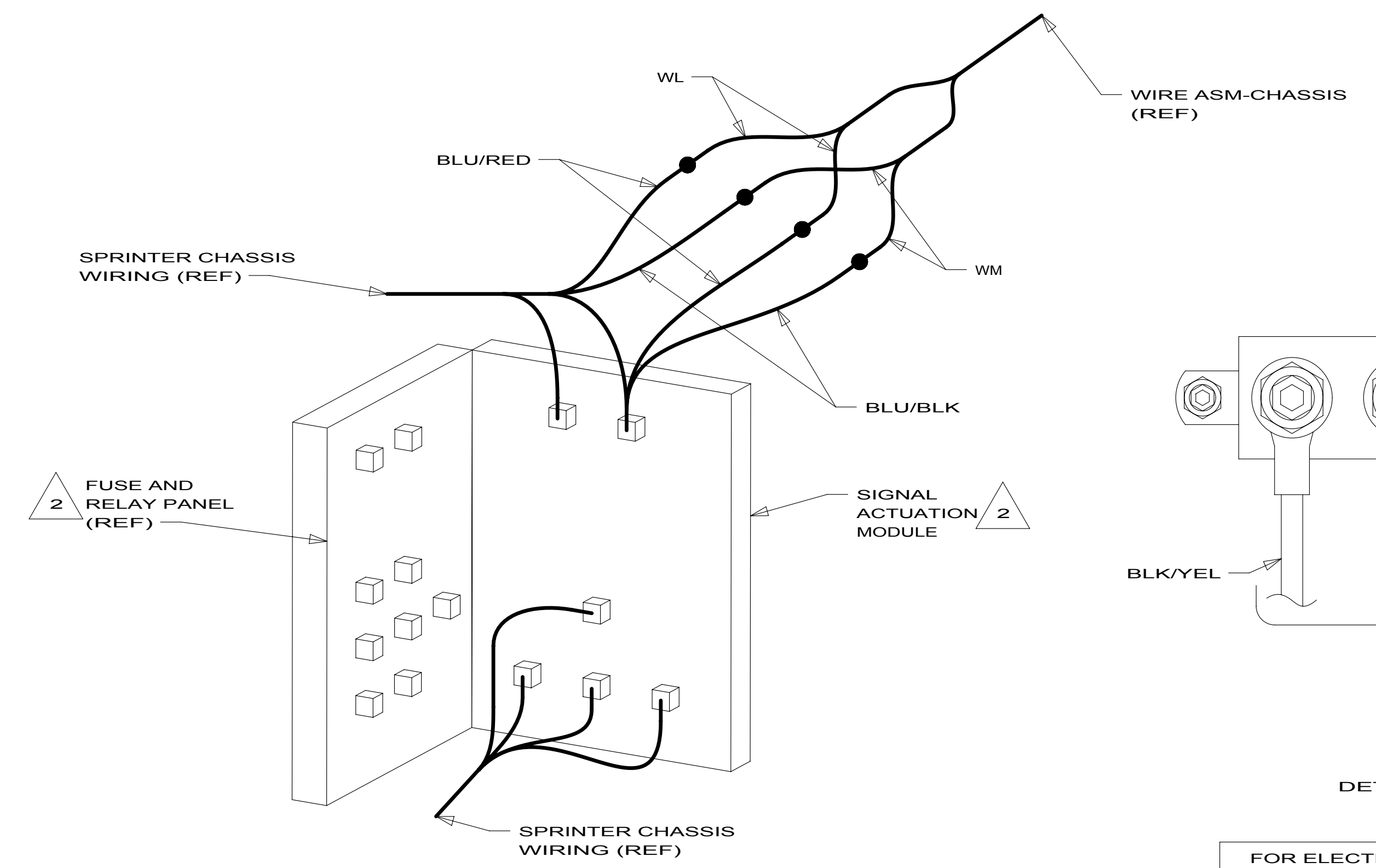

VIEW CB

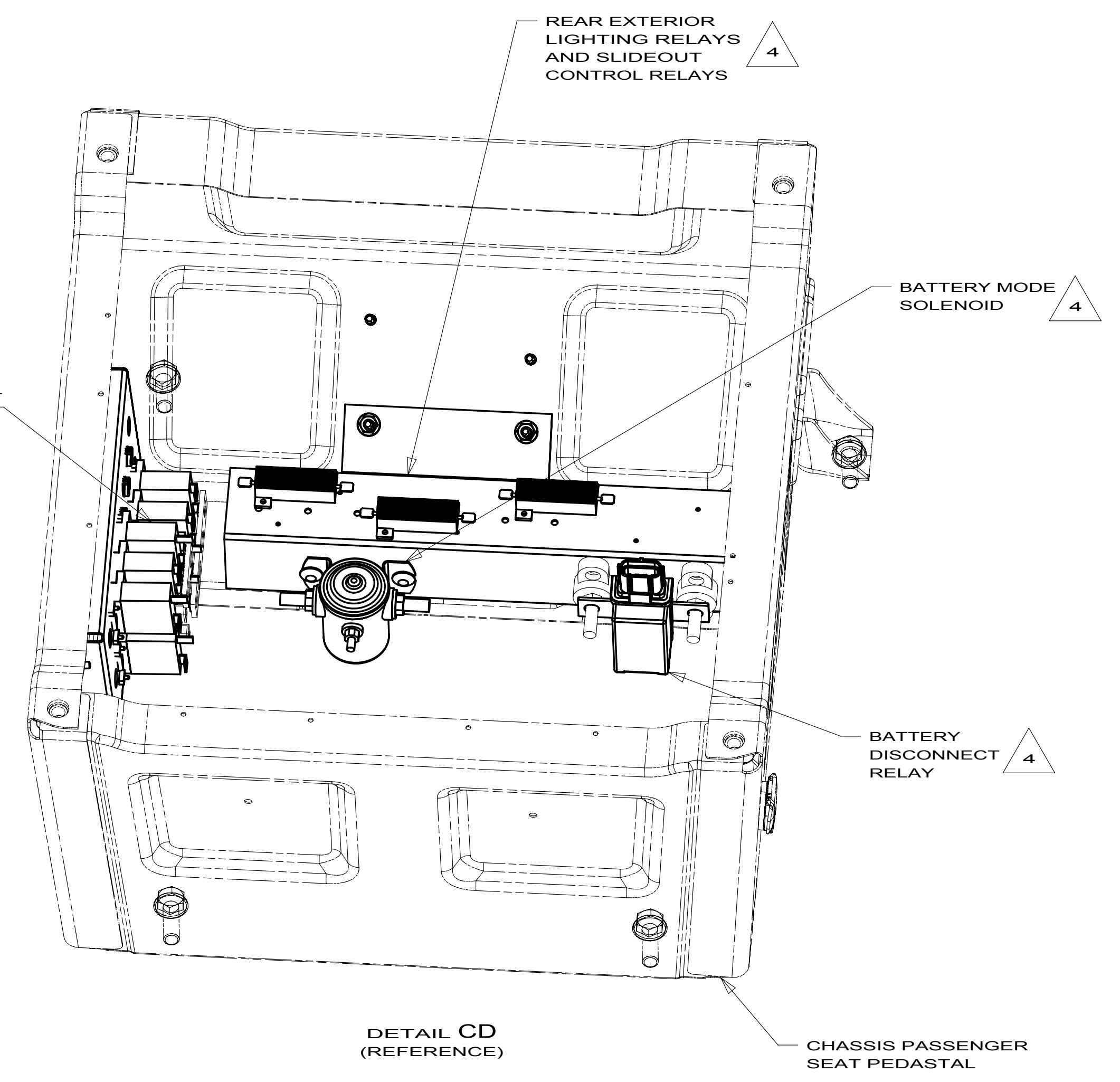

DETAIL CD (REFERENCE)

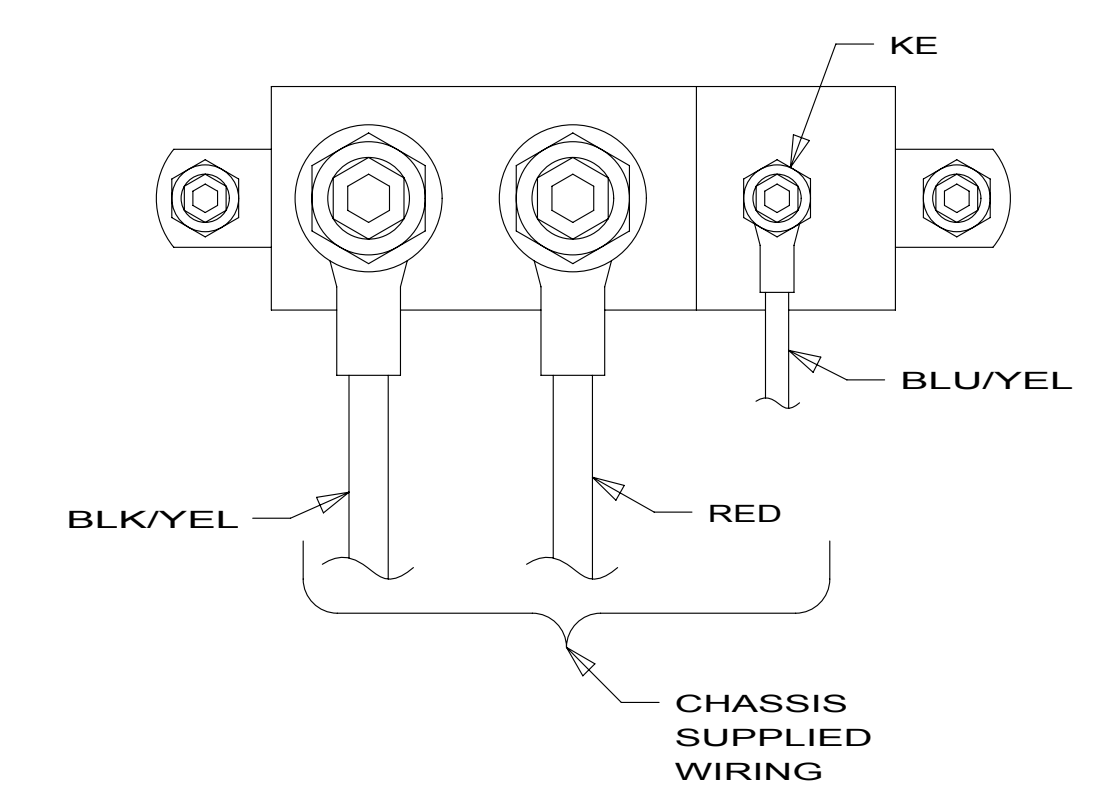

DETAIL CC (3)

- NOTES:
- 4 SEE CHASSIS ELECTRICAL BOX ASM FOR ADDITIONAL INFORMATION.
 - 3 CONNECTION POINT IS LOCATED UNDER DRIVERS SEAT.
 - 2 LOCATED IN DRIVERS SIDE KICKER PANEL.
 - 1. SECURE CONDUIT 41953, TAB AS REQUIRED, OVER ALL WIRES IN CONTACT WITH SHARP EDGES.

FOR ELECTRICAL TORQUE SPECIFICATIONS SEE DWG NO. 128783-01-000

FOR ELECTRICAL CALLOUTS SEE DWG NO. 121339-01-000

- 1MD MERCEDES-11.030# GVWR,DIESEL
- 265 CODES/STANDARDS-CSA/CMVSS
- 1B1 CODES/STANDARDS USA

FIRST USED	13 524V	
DO NOT SCALE DRAWING		
TITLE: WIRING INSTL-CHASSIS		
SHEET 3	PART NO. 180586	REV