



DANGER

Danger of electrical shock, burns or death. Always remove all power sources before attempting any repair, service or diagnostic work. Power can be present from shore power, generator, inverter or battery. All power sources must be disabled and secured before performing any service.



CAUTION

If you lack the skills, tools or equipment to perform diagnostic or repair work leave such work to an authorized Winnebago Industries dealer or other qualified shop.

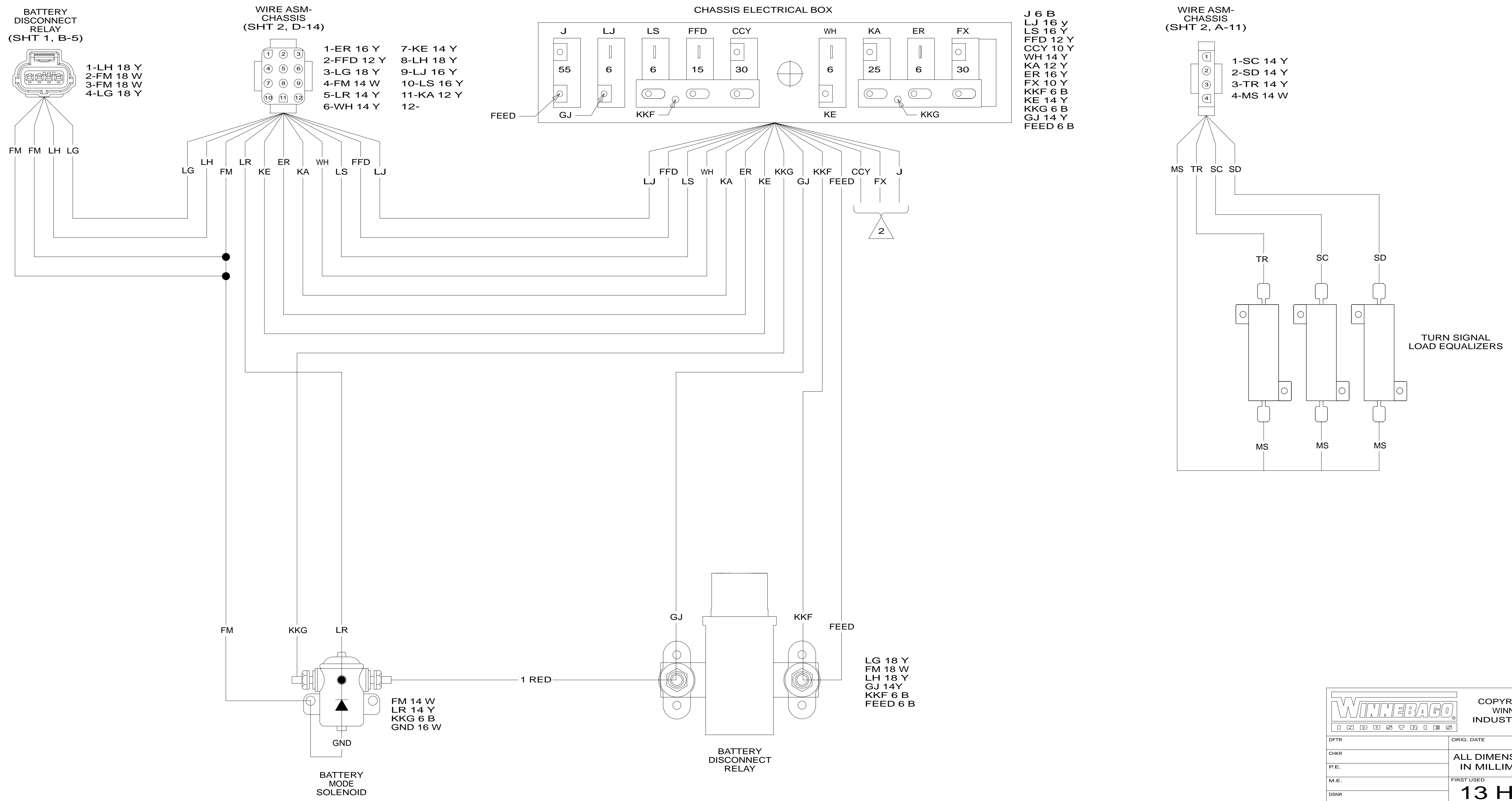

2 CIRCUT IS FROM WIRE ASM-CHASSIS.

1. SPLICES ARE THEORETICAL AND MAY DIFFER IN THE HARNESS.

NOTES:
 1- 7-
 2- 8-
 3- 9-

WIRING DIAGRAM-ELECTRICAL BOX
 (WIRE ASM 124125-15 REV-BS)

WINNEBAGO COPYRIGHT 2011 WINNEBAGO INDUSTRIES, INC.

DFTR	ORIG. DATE
CHKR	ALL DIMENSIONS ARE IN MILLIMETERS
P.E.	
M.E.	FIRST USED
DSNR	13 H25T
UNSPECIFIED TOLERANCES ARE:	MATERIAL:
WHOLE DIM (X) :	
ONE-PLACE (X.X) :	
TWO-PLACE (X.XX) :	
ANGLE :	
THIRD ANGLE PROJECTION	
DO NOT SCALE DRAWING	REFER TO ES0018 FOR FASTENER TIGHTENING GUIDELINES
TITLE: WIRING DIAGRAM-BODY,12V	
SHEET 1 OF 8	PART NO 180429 REV
REF: 1	22-Aug-2012

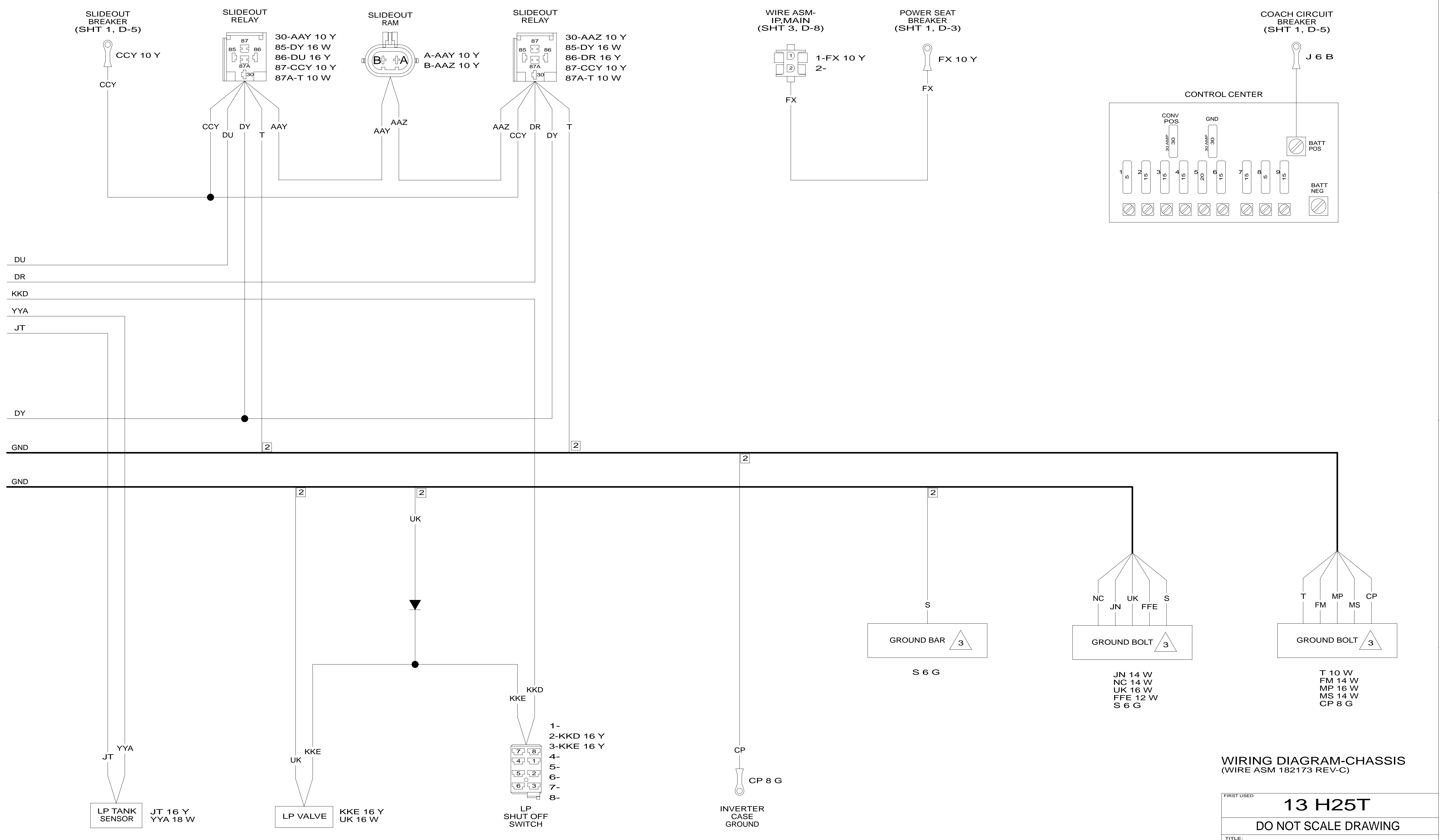

WIRING DIAGRAM-CHASSIS (WIRE ASM 182173 REV-C)

FIRST USED	13 H25T		
TITLE:	DO NOT SCALE DRAWING		
TITLE:	WIRING DIAGRAM-BODY,12V		
SHEET 2	PART NO	180429	REV

D

C

B

A

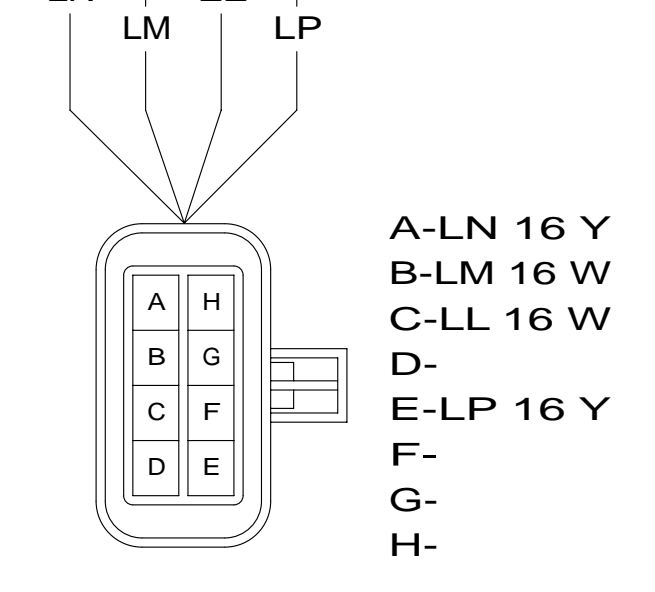
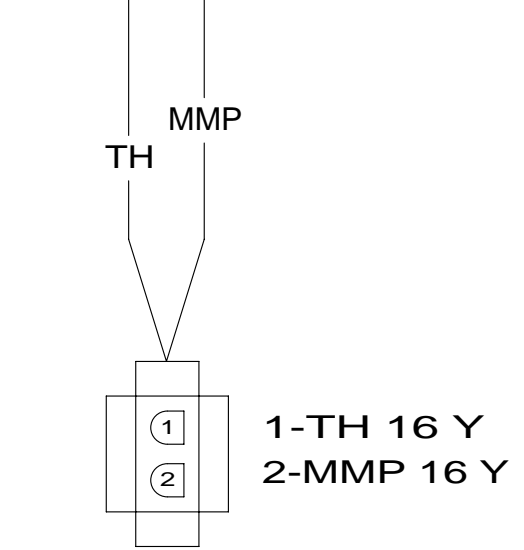
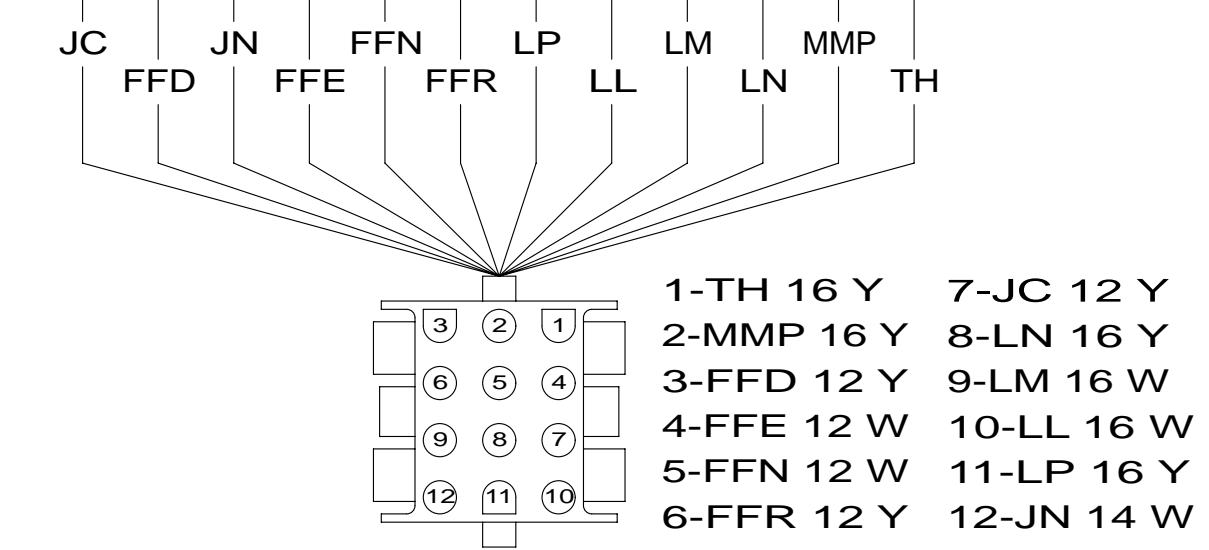
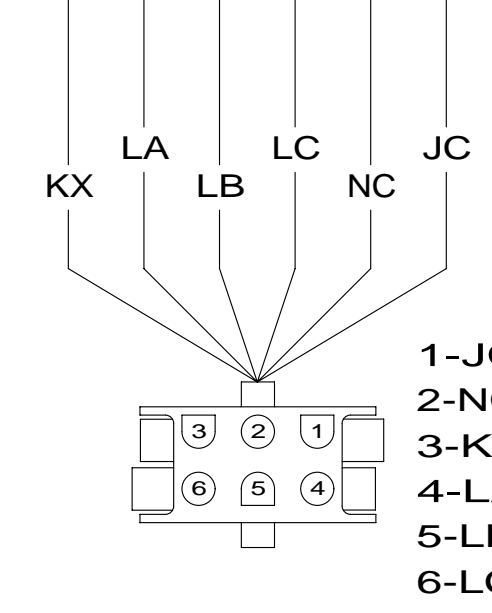
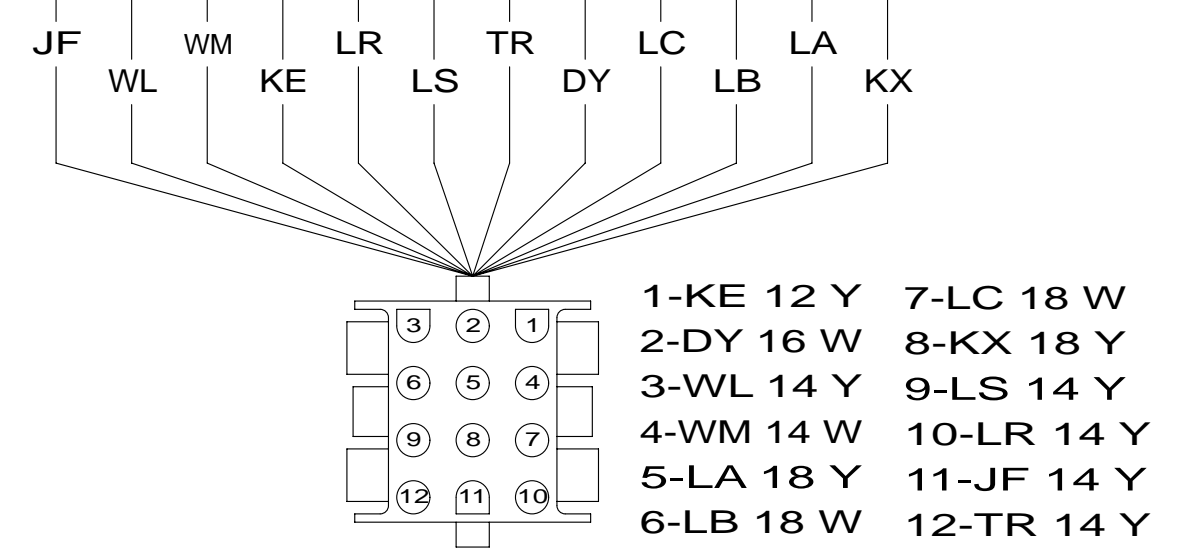
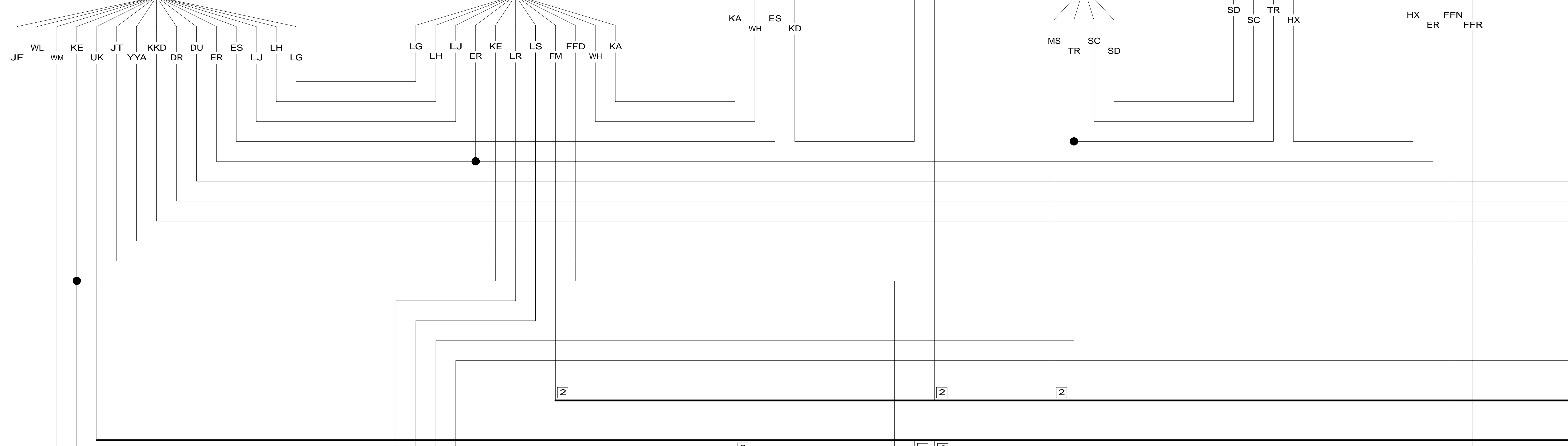
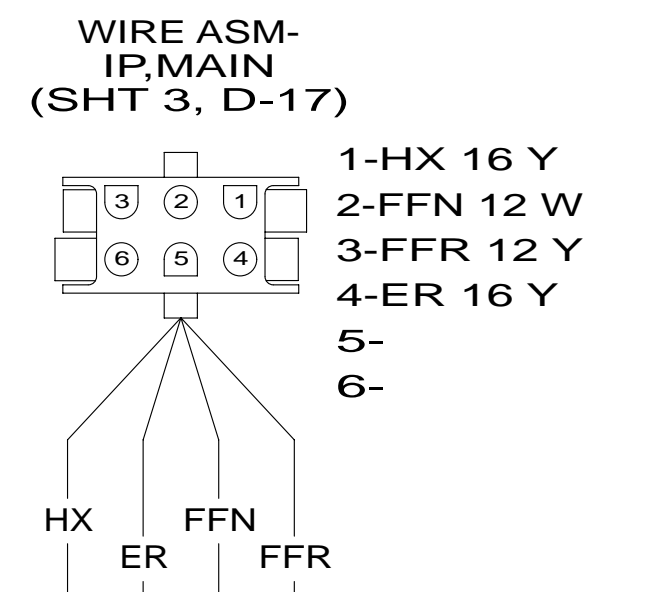
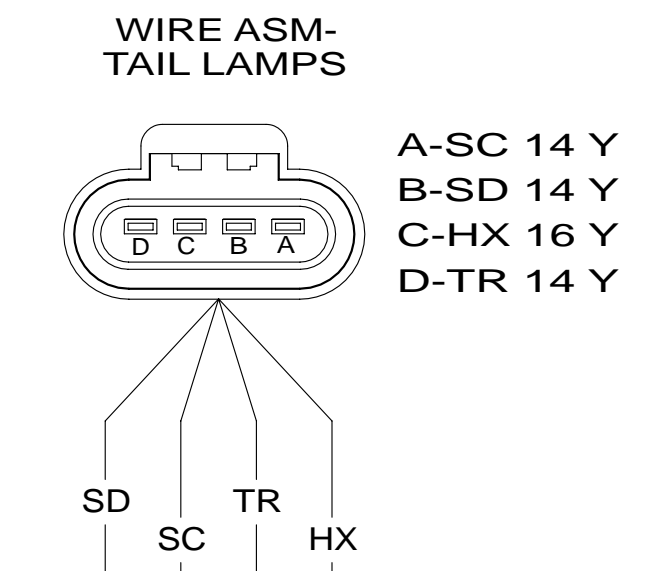
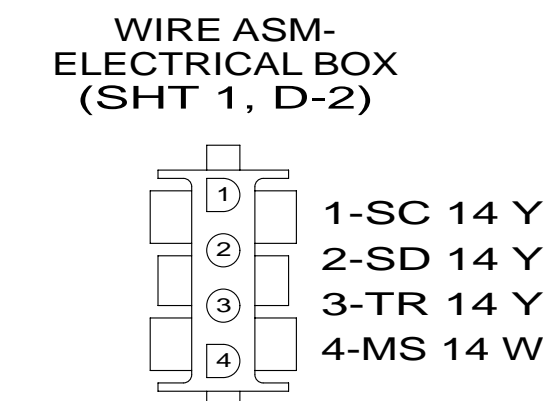
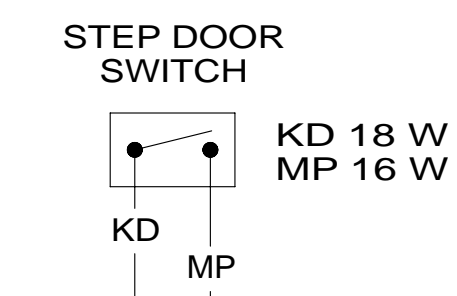
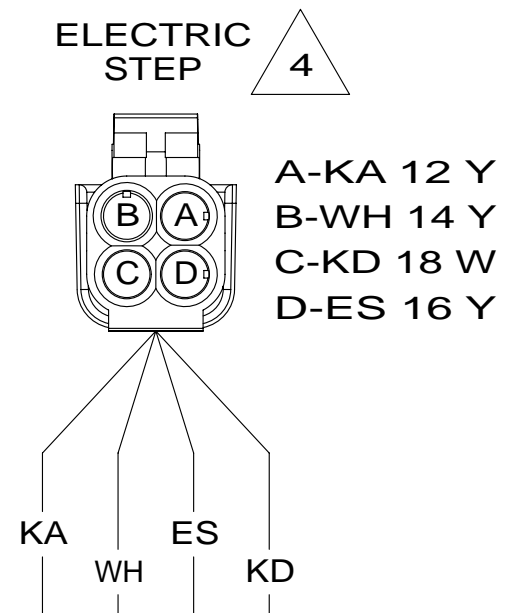
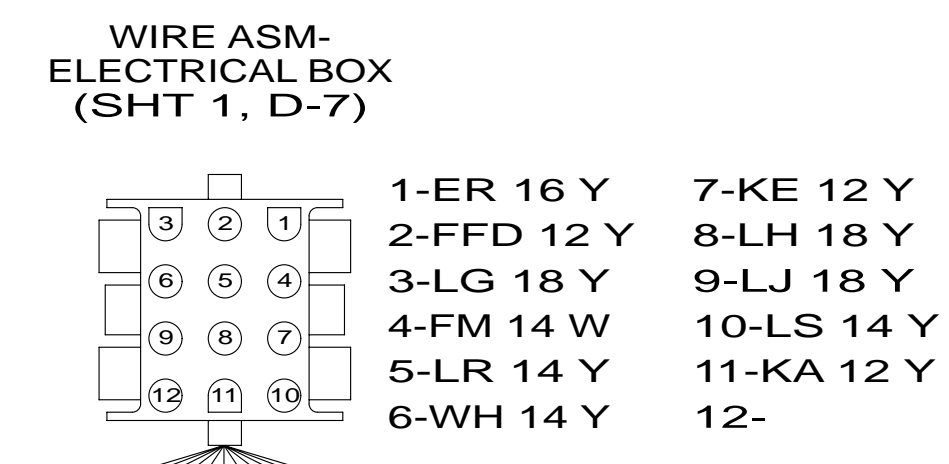
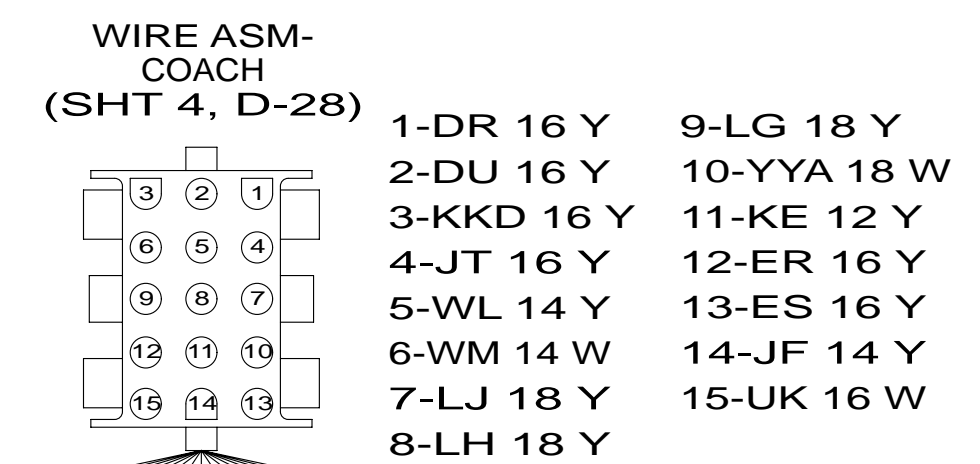

- 4 SEE MANUFACTURERS DIAGRAM FOR ADDITIONAL INFORMATION.
- 3 GROUNDS ARE SHOWN AS A SINGLE LINE FOR EASE IN TRACING. EACH GROUND CIRCUIT IS SEPERATE IN THE HARNESS.
- 2 NOT A SPLICE POINT. INDICATES ENTRY INTO WIRING HARNESS.
1. SPLICES ARE THEORETICAL AND MAY DIFFER IN THE HARNESS.

NOTES:

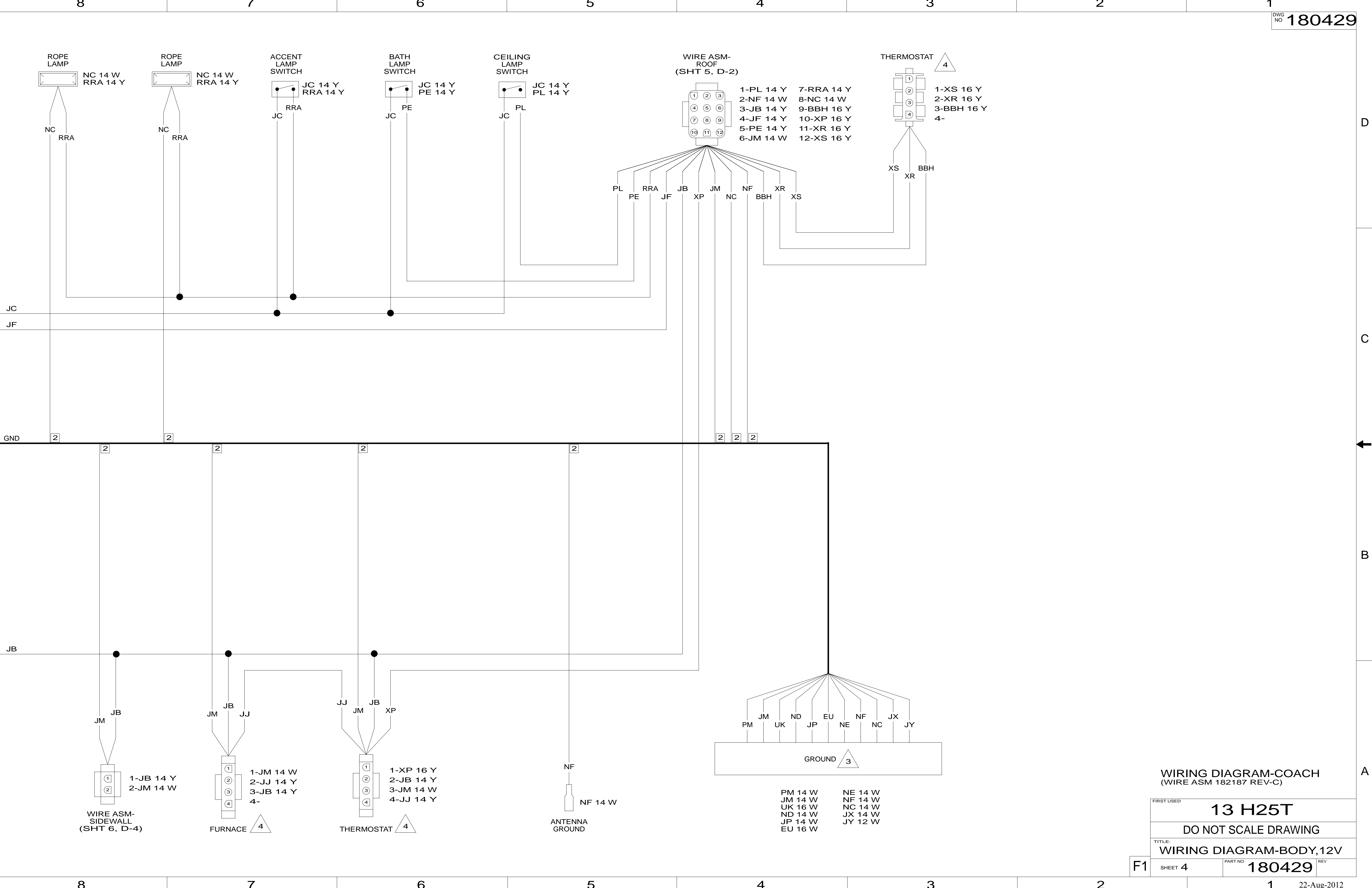

WIRING DIAGRAM-COACH
(WIRE ASM 182187 REV-C)

FIRST USED
13 H25T

DO NOT SCALE DRAWING

TITLE:
WIRING DIAGRAM-BODY, 12V

F1 SHEET 4 PART NO 180429 REV

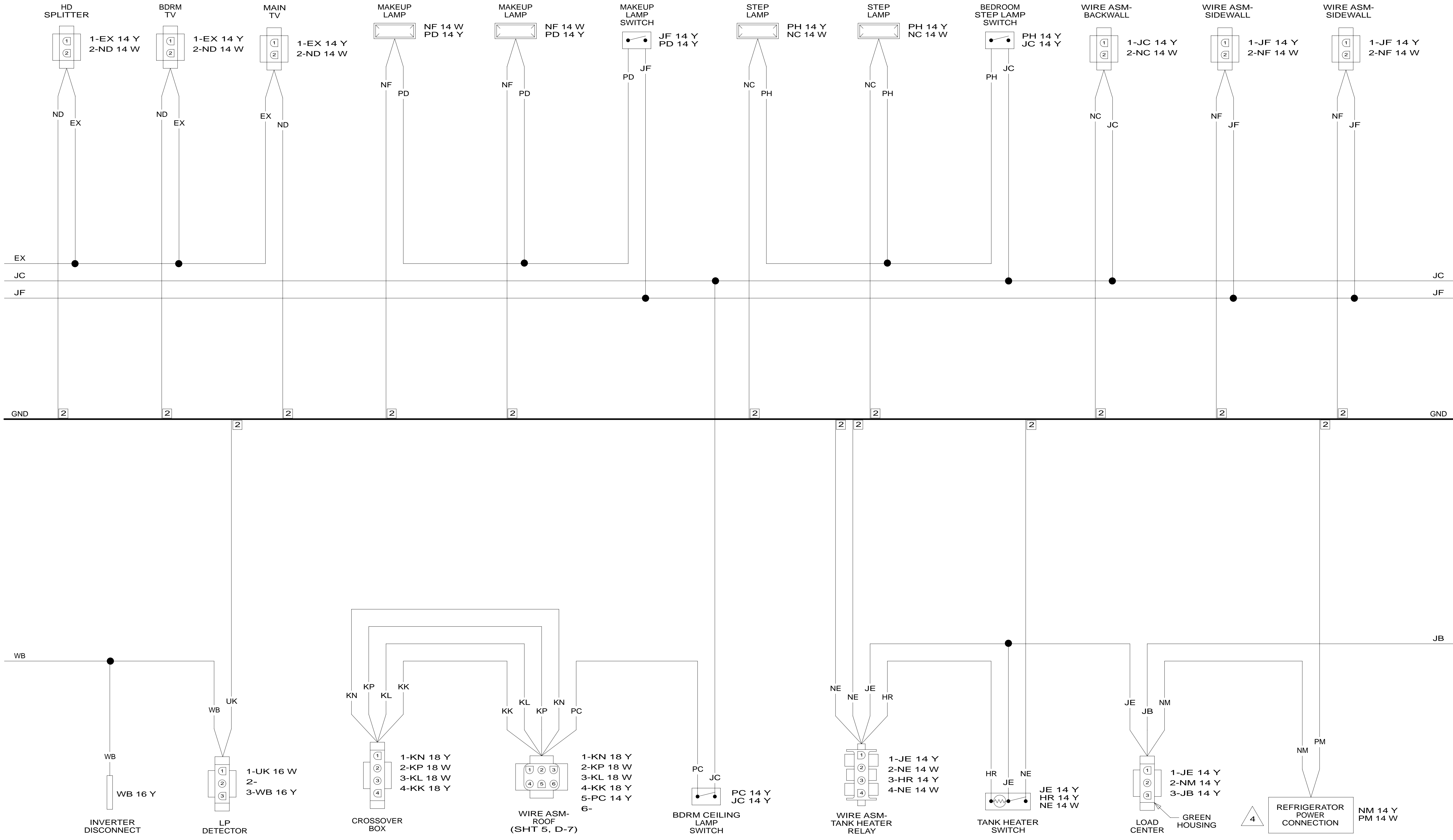

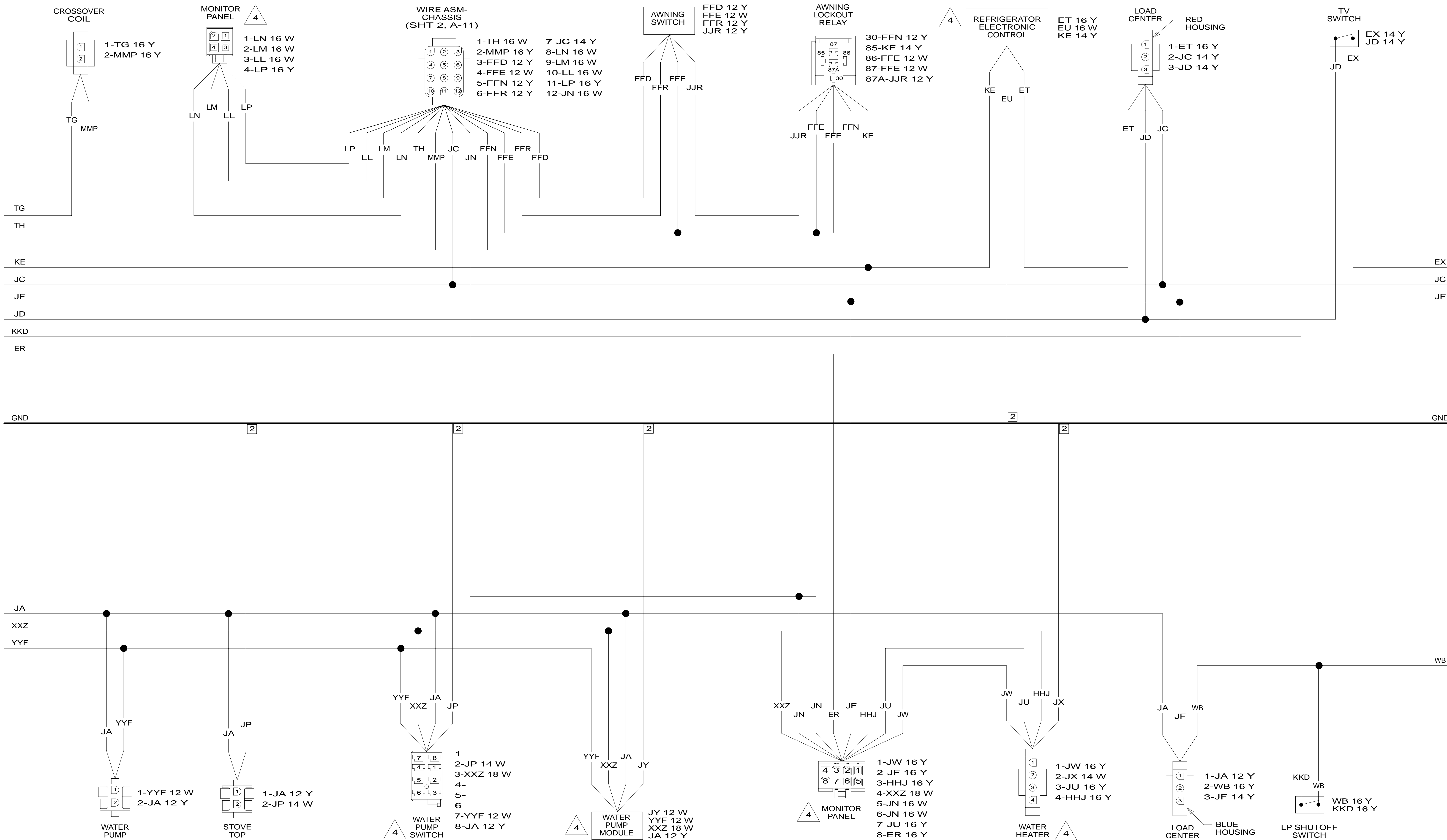

D

C

B

A

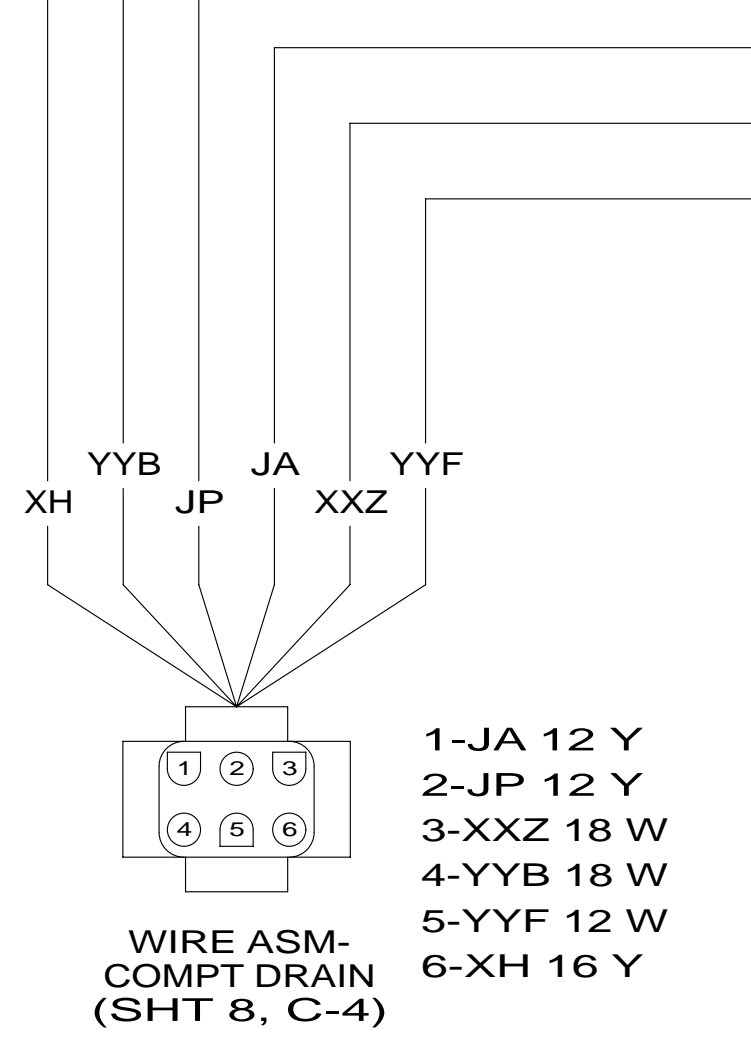
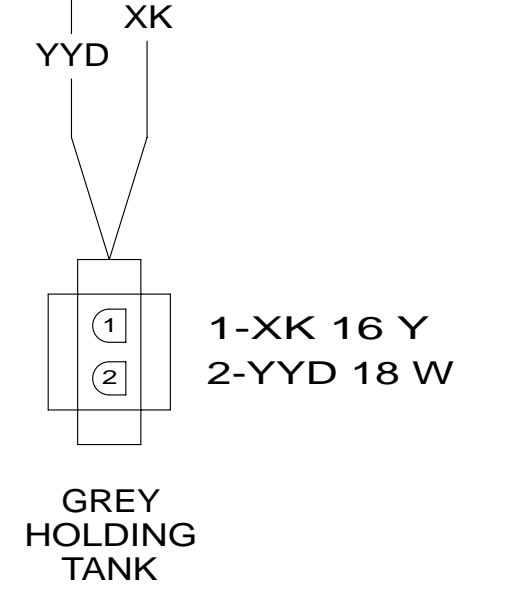
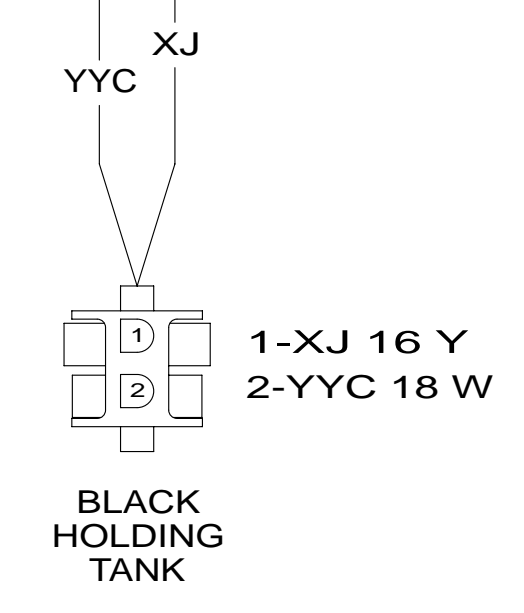
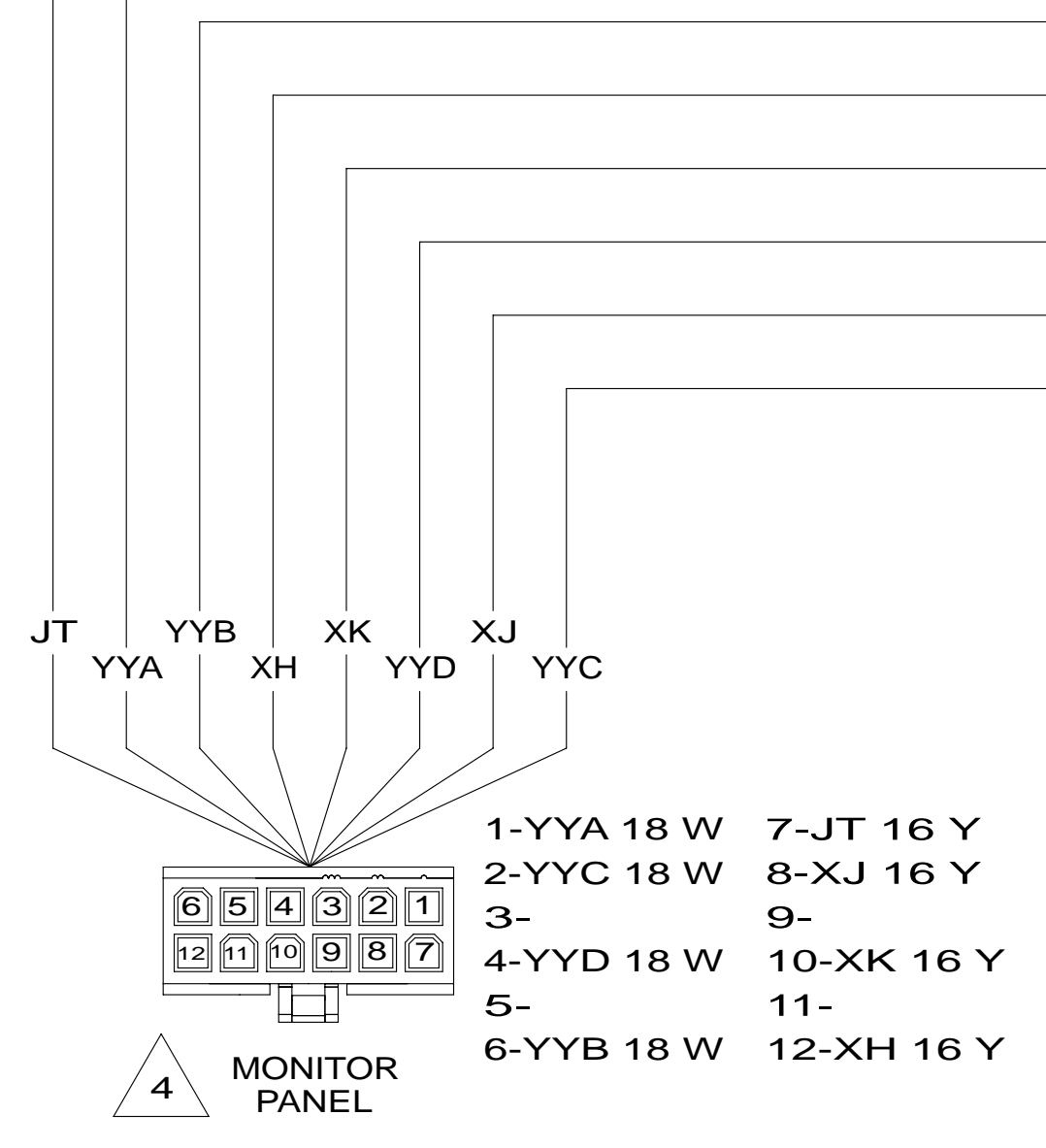
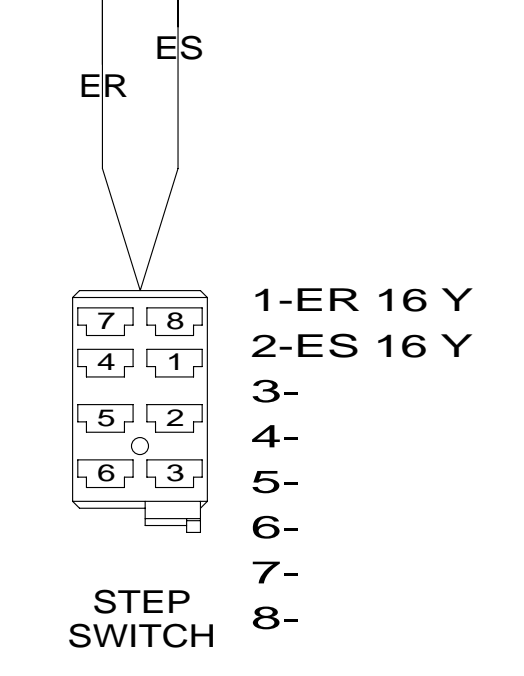
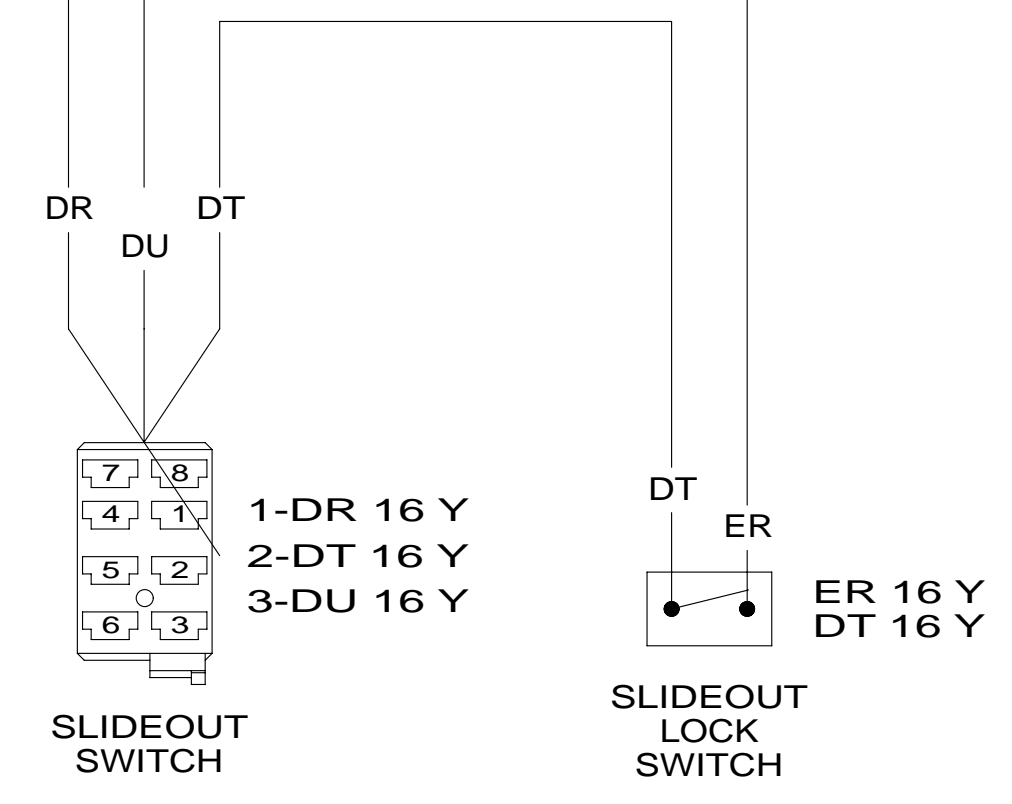
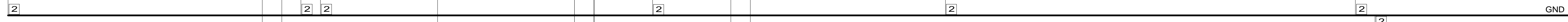
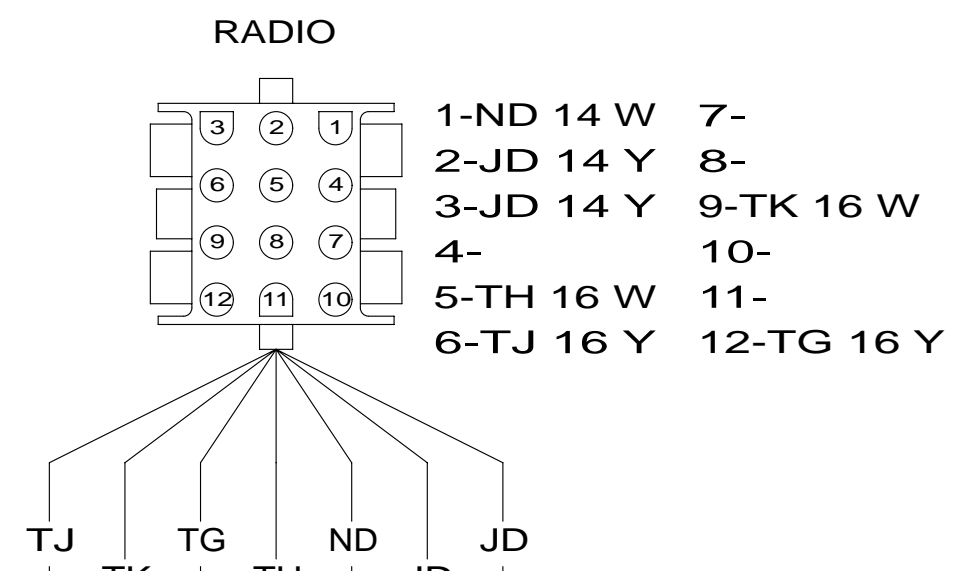
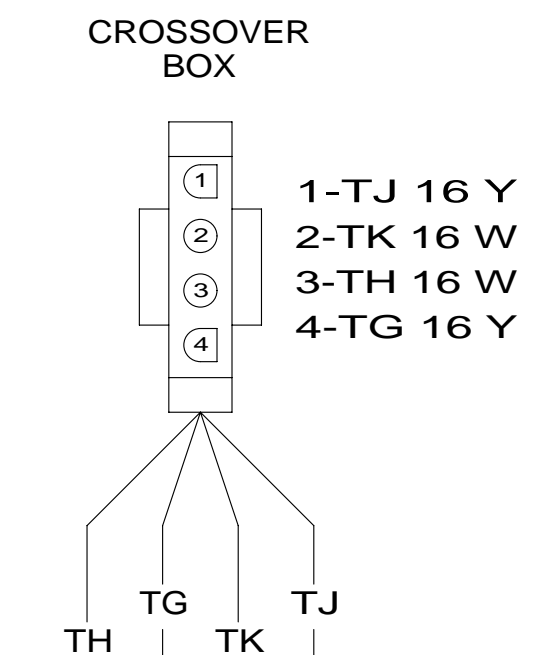
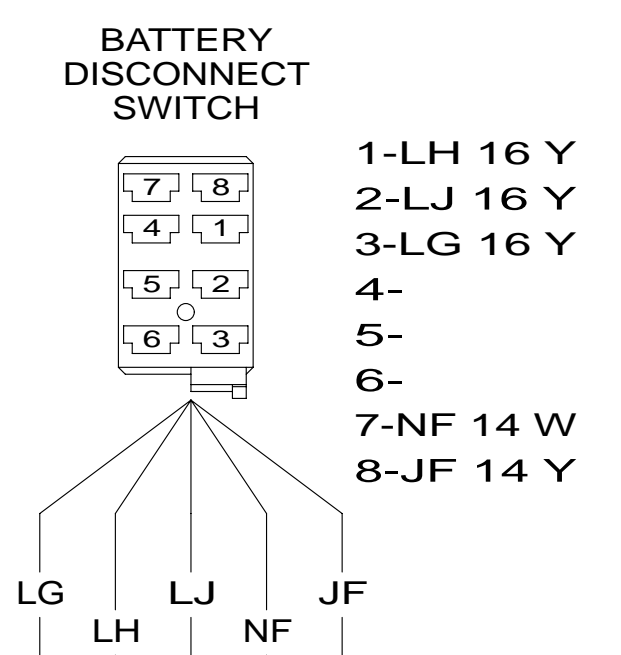
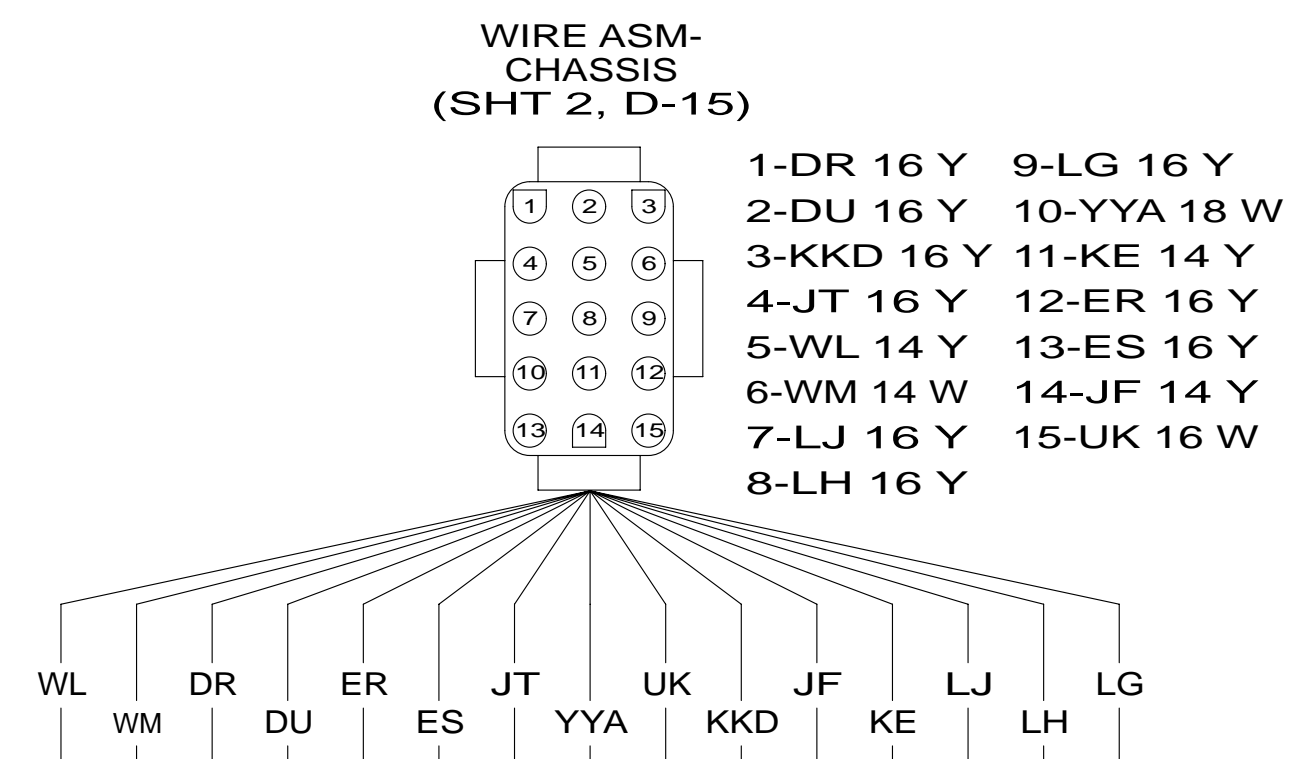
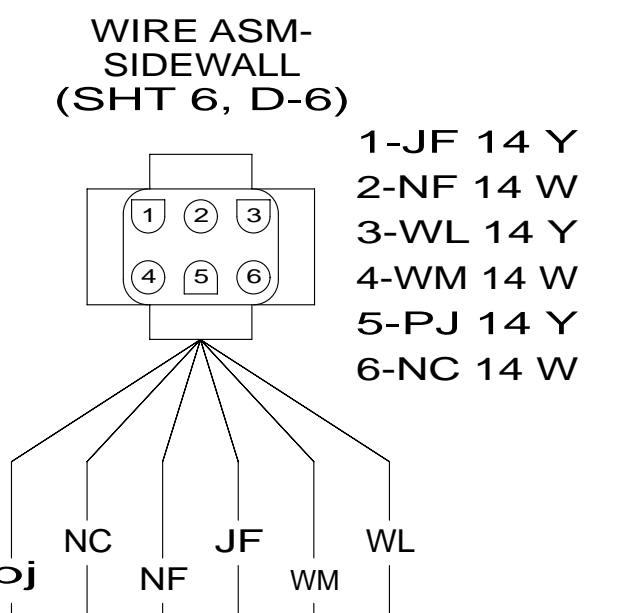
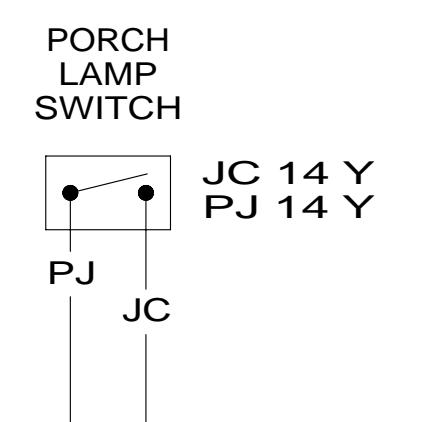
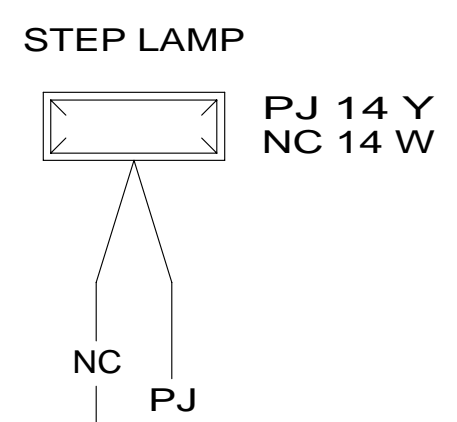

- 4 SEE MANUFACTURERS DIAGRAM FOR ADDITIONAL INFORMATION.
- 3 GROUNDS ARE SHOWN AS A SINGLE LINE FOR EASE IN TRACING. EACH GROUND CIRCUIT IS SEPERATE IN THE HARNESS.
- 2 NOT A SPLICE POINT. INDICATES ENTRY INTO WIRING HARNESS.

NOTES:
1. SPLICES ARE THEORETICAL AND MAY DIFFER IN THE HARNESS.

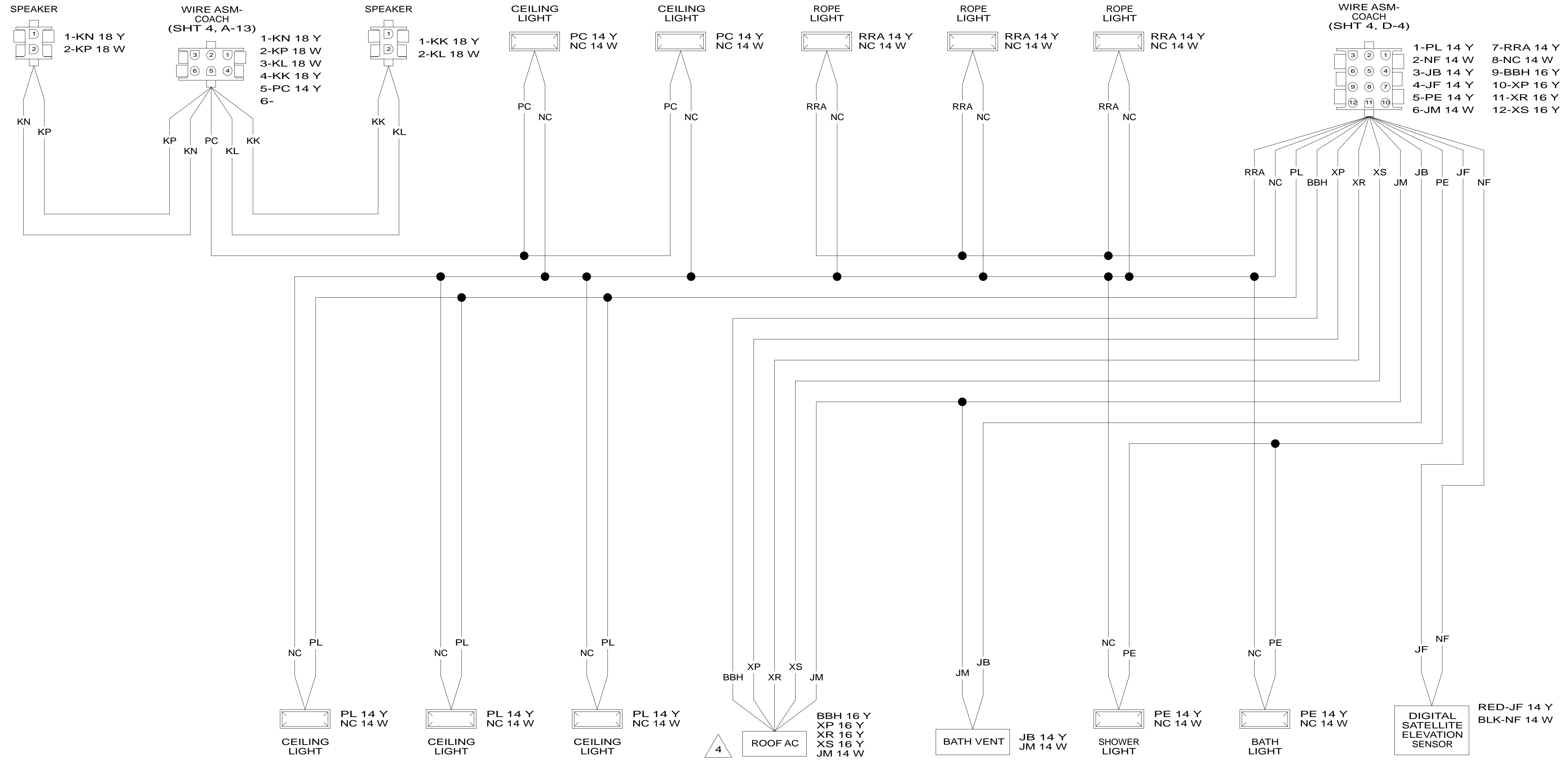

- 4 SEE MANUFACTURERS DIAGRAM FOR ADDITIONAL INFORMATION.
- 3 GROUNDS ARE SHOWN AS A SINGLE LINE FOR EASE IN TRACING. EACH GROUND CIRCUIT IS SEPERATE IN THE HARNESS.
- 2 NOT A SPLICE POINT. INDICATES ENTRY INTO WIRING HARNESS.
1. SPLICES ARE THEORETICAL AND MAY DIFFER IN THE HARNESS.

NOTES:

FIRST USED		13 H25T	
DO NOT SCALE DRAWING			
TITLE: WIRING DIAGRAM-BODY,12V			
SHEET 5	PART NO	180429	REV
		1	22-Aug-2012

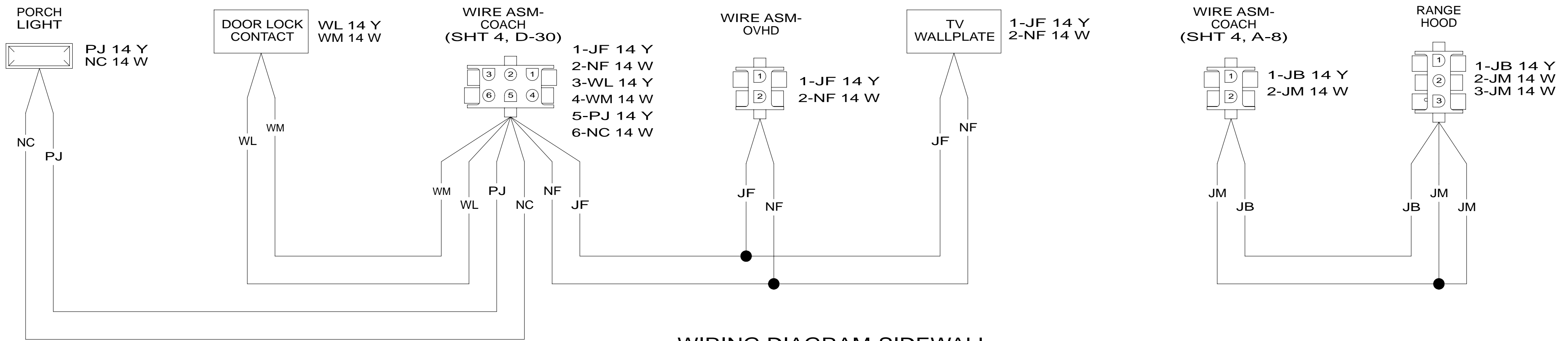

WIRING DIAGRAM-SIDEWALL
(WIRE ASM 182190 REV-A)

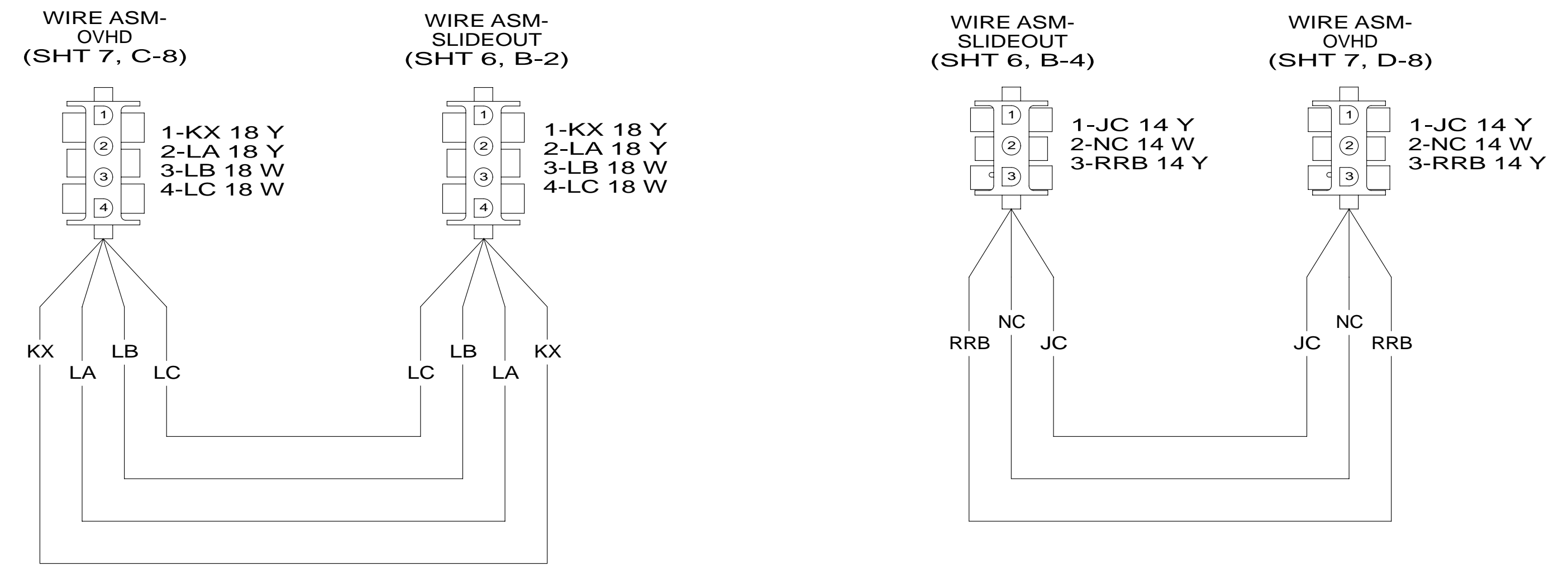

WIRING DIAGRAM-SIDEWALL
(WIRE ASM 178855 REV-A)

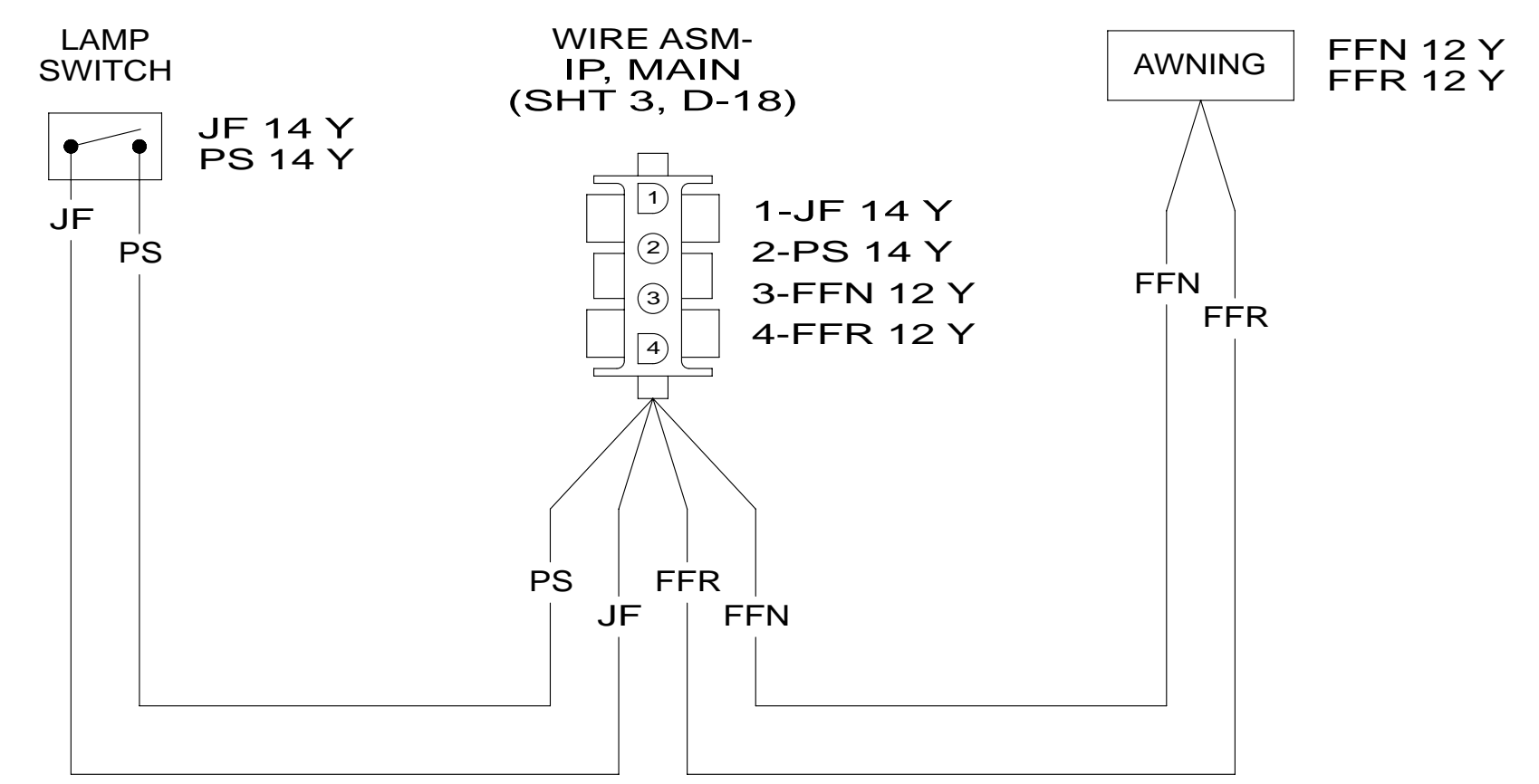

WIRING DIAGRAM-SIDEWALL,FRONT
(WIRE ASM 182541 REV-A)

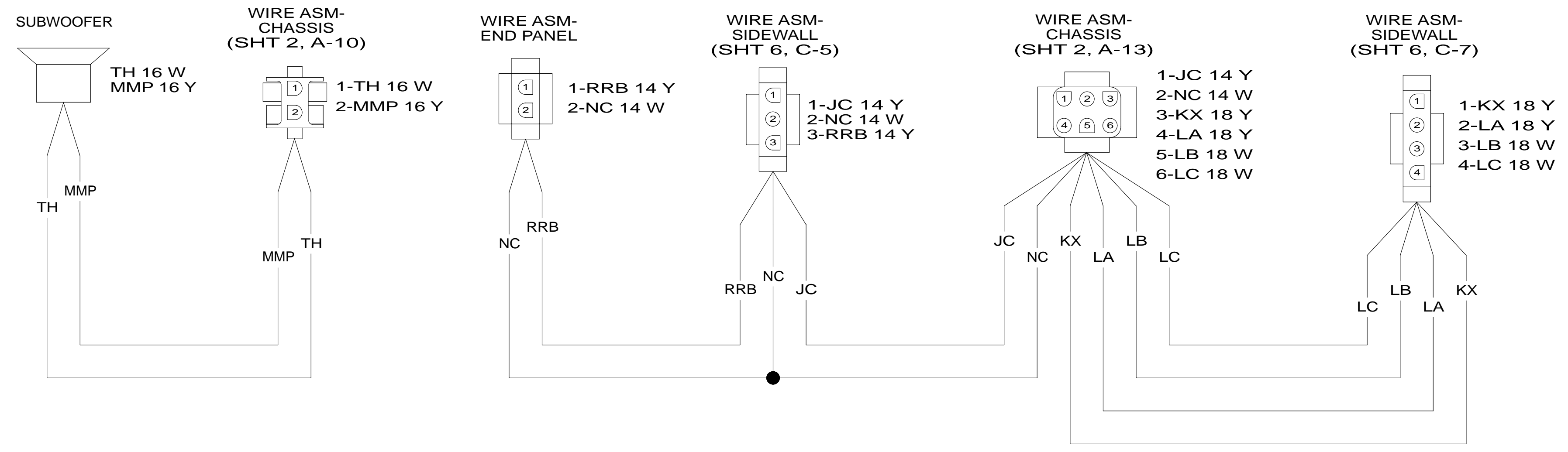

WIRING DIAGRAM-SLIDEOUT
(WIRE ASM 178888 REV-B)

- NOTES:
- 3 GROUND ARE SHOWN AS A SINGLE LINE FOR EASE IN TRACING. EACH GROUND CIRCUIT IS SEPERATE IN THE HARNESS.
 - 2 NOT A SPLICE POINT. INDICATES ENTRY INTO WIRING HARNESS.
 - 1. SPLICES ARE THEORETICAL AND MAY DIFFER IN THE HARNESS.

FIRST USED	13 H25T	
DO NOT SCALE DRAWING		
TITLE: WIRING DIAGRAM-BODY,12V		
SHEET 6	PART NO 180429	REV

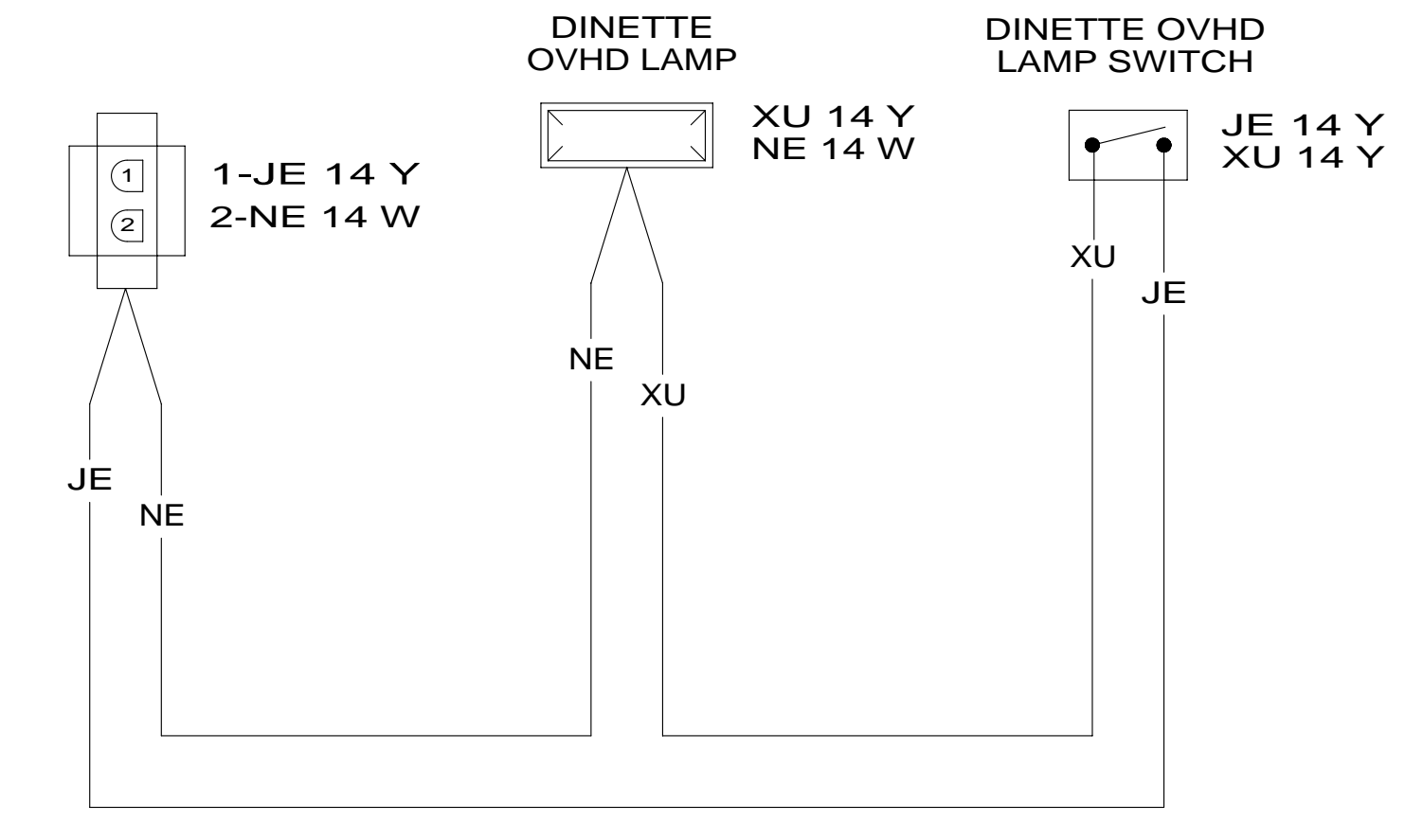
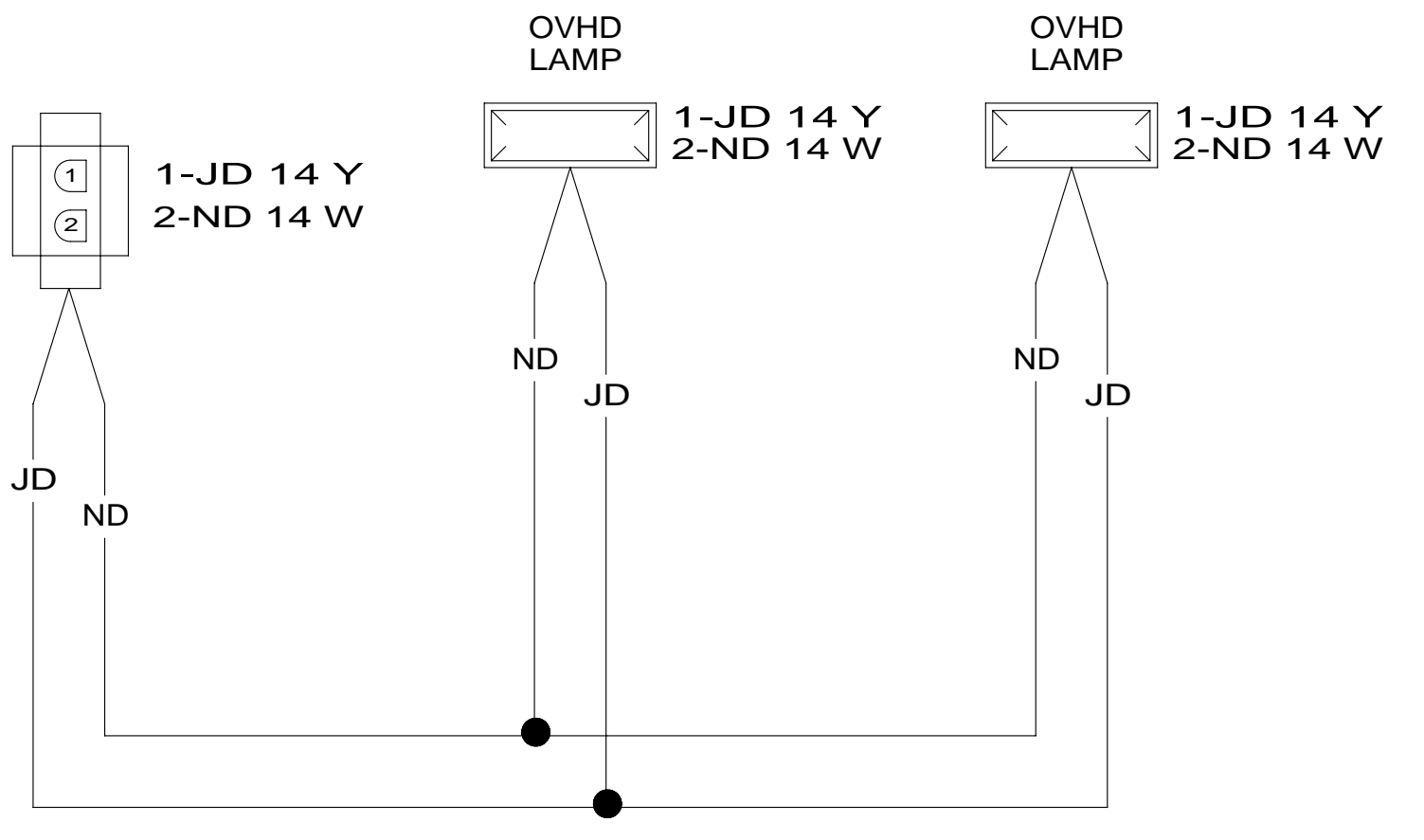
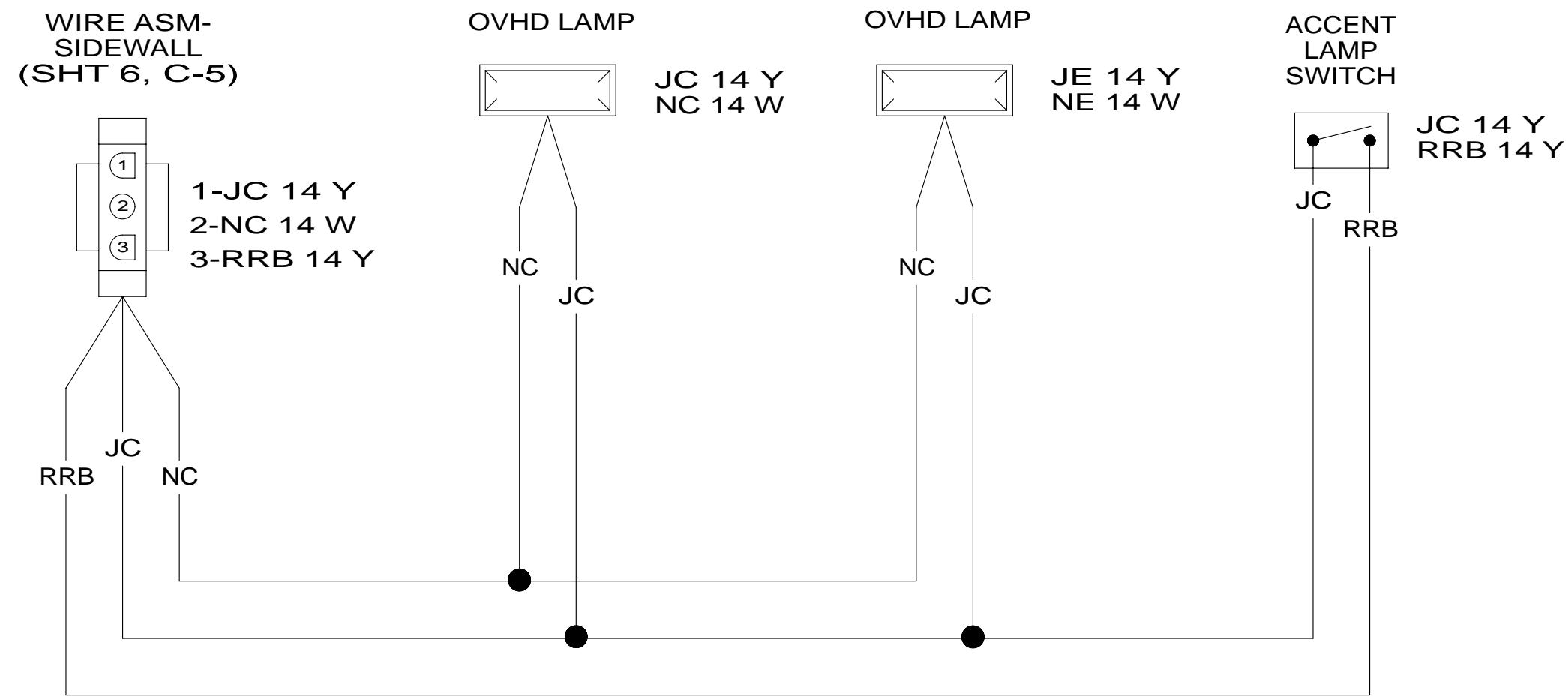

WIRING DIAGRAM-OVHD
(WIRE ASM 171279 REV-B)

WIRING DIAGRAM-OVHD
(WIRE ASM 149917 REV-B)

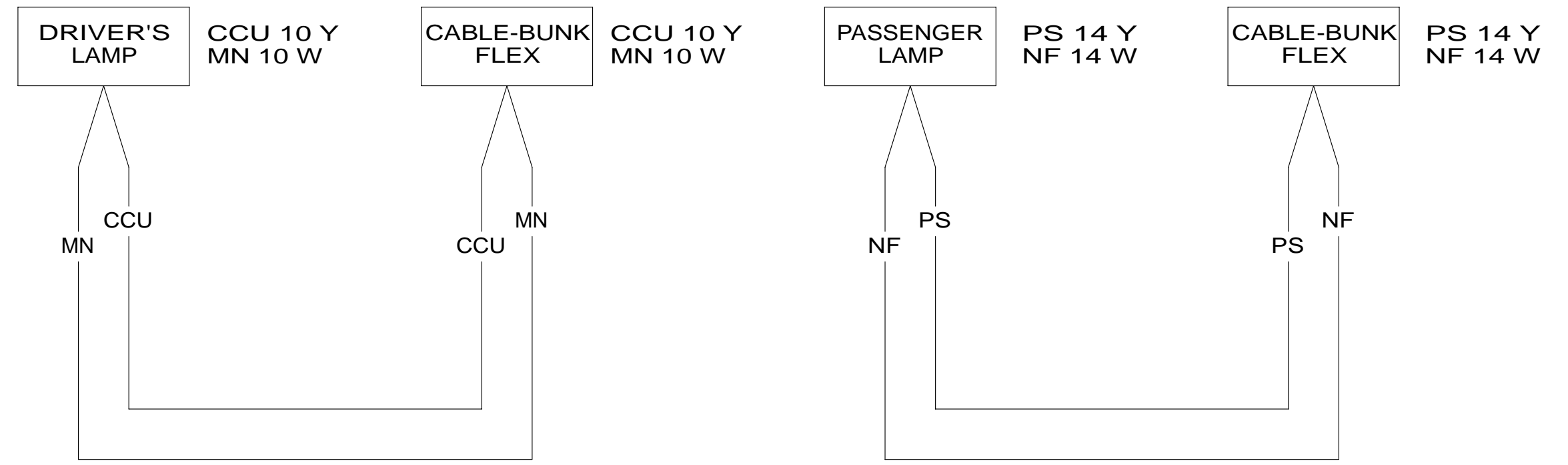
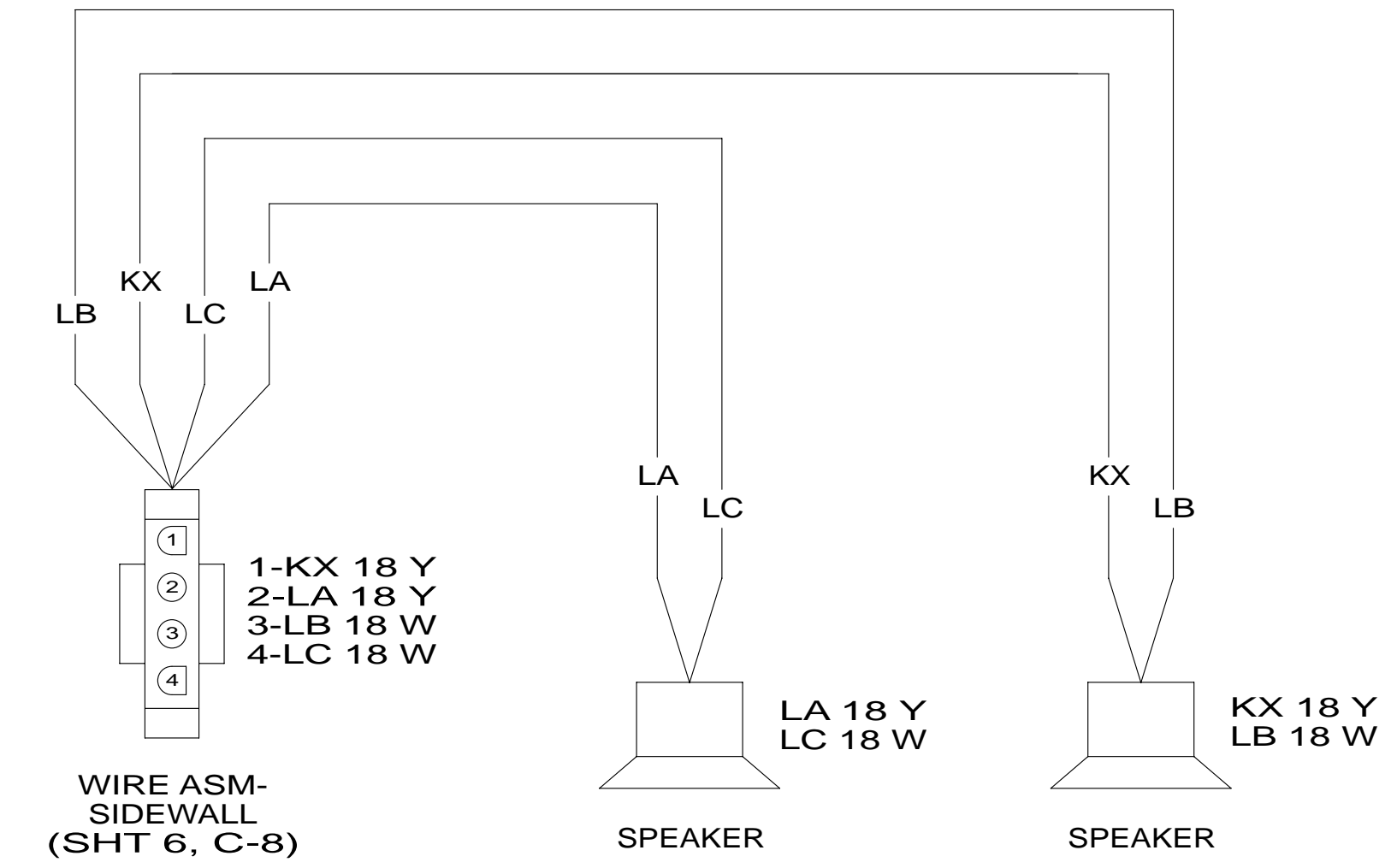

WIRING DIAGRAM-OVHD
(WIRE ASM 178891 REV-A)

WIRING DIAGRAM-BUNK
(WIRE ASM 171484 REV-C)

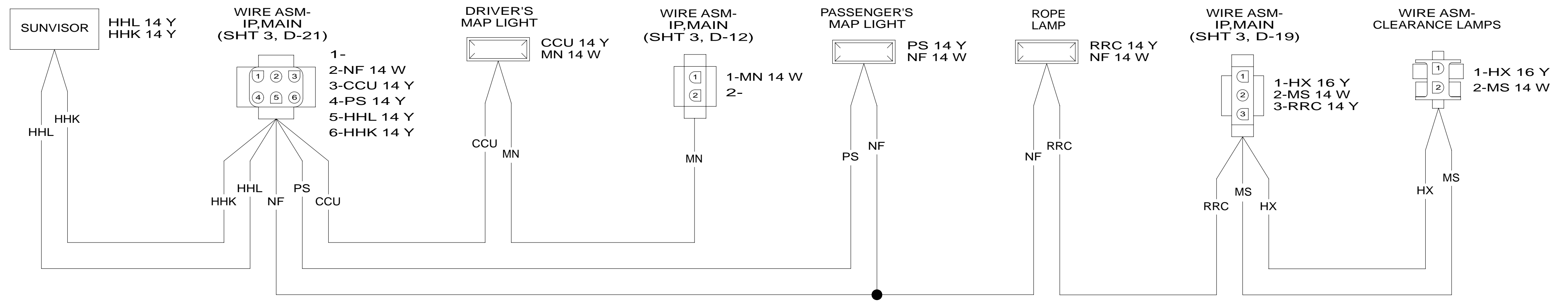

WIRING DIAGRAM-OVHD,FRT
(WIRE ASM 179785 REV-A)

- 3 GROUND ARE SHOWN AS A SINGLE LINE FOR EASE IN TRACING. EACH GROUND CIRCUIT IS SEPERATE IN THE HARNESS.
- 2 NOT A SPLICE POINT. INDICATES ENTRY INTO WIRING HARNESS.
1. SPLICES ARE THEORETICAL AND MAY DIFFER IN THE HARNESS.

FIRST USED	13 H25T	
DO NOT SCALE DRAWING		
TITLE: WIRING DIAGRAM-BODY,12V		
SHEET 7	PART NO 180429	REV

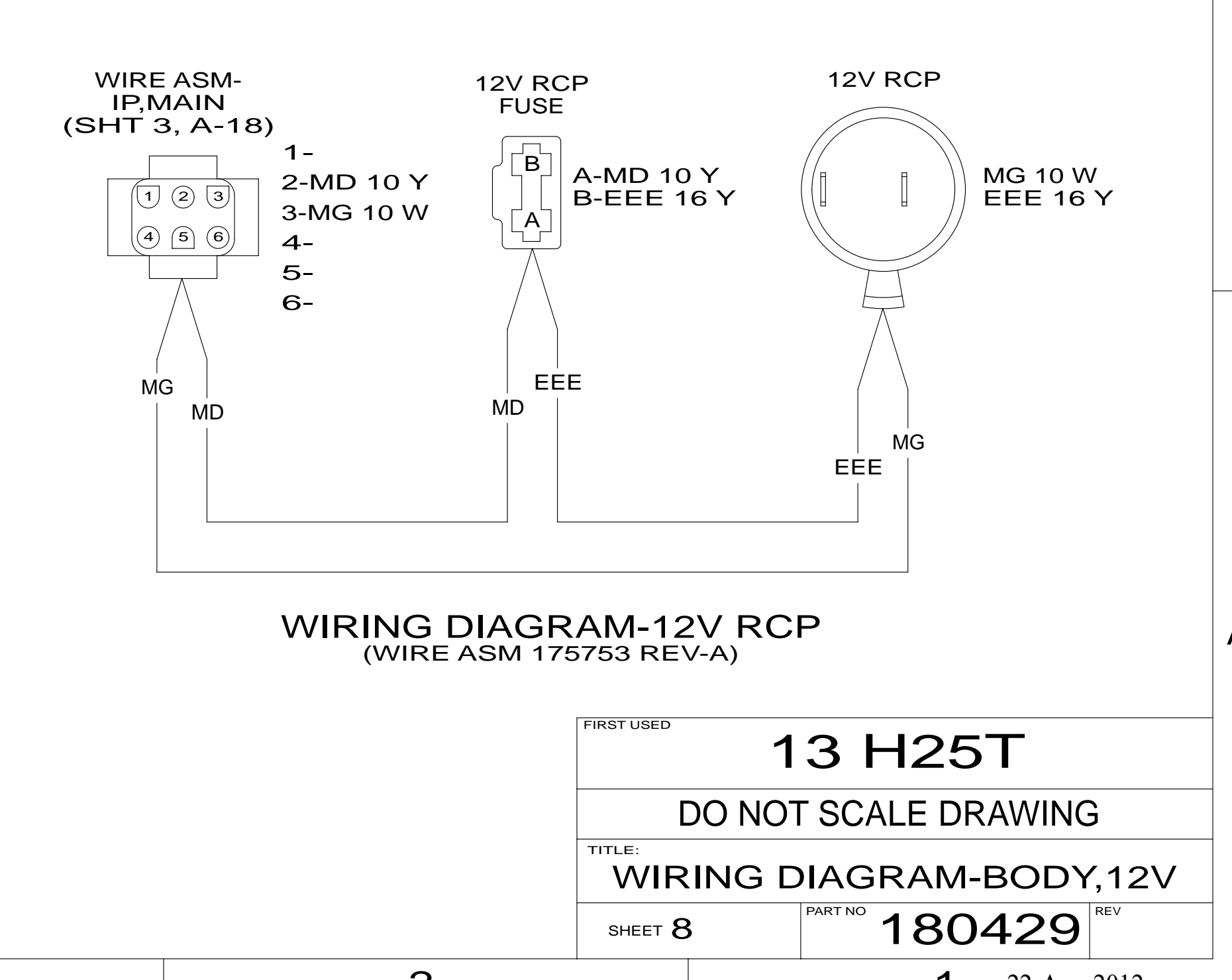
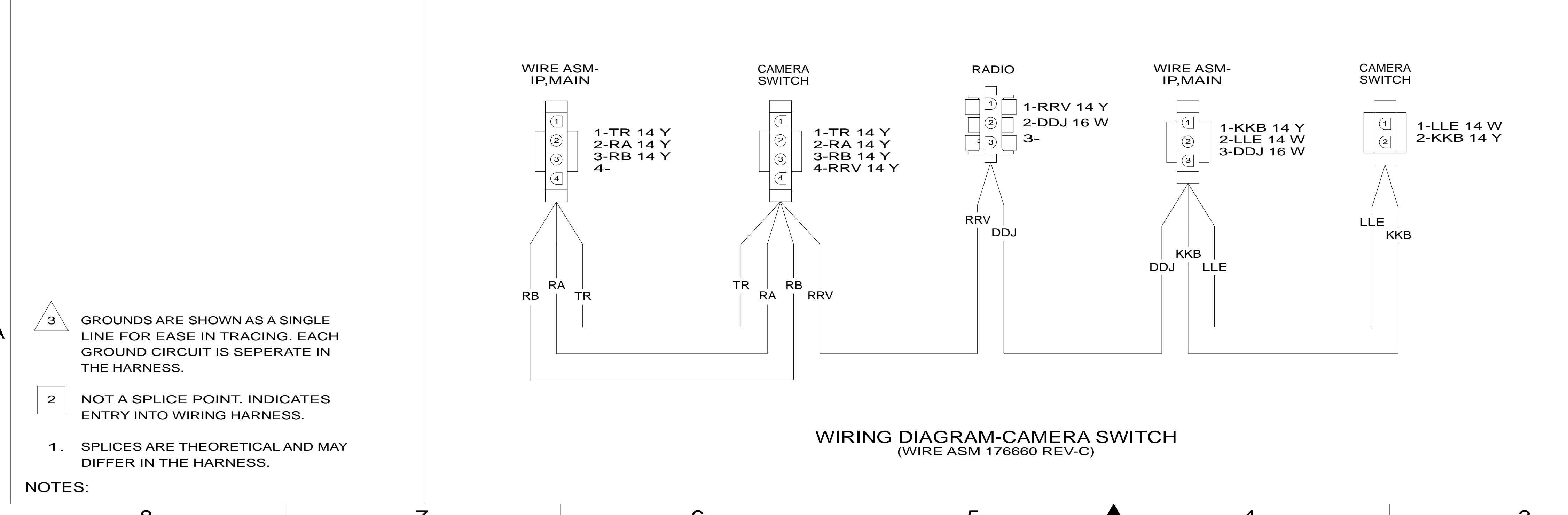
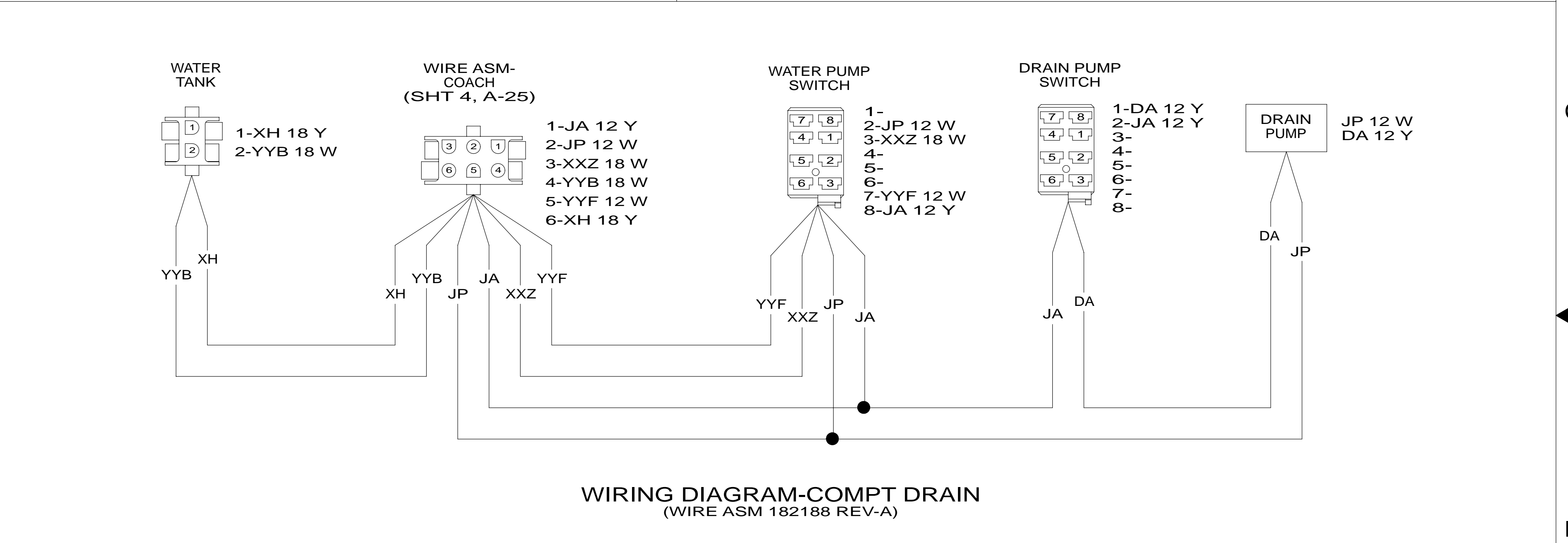
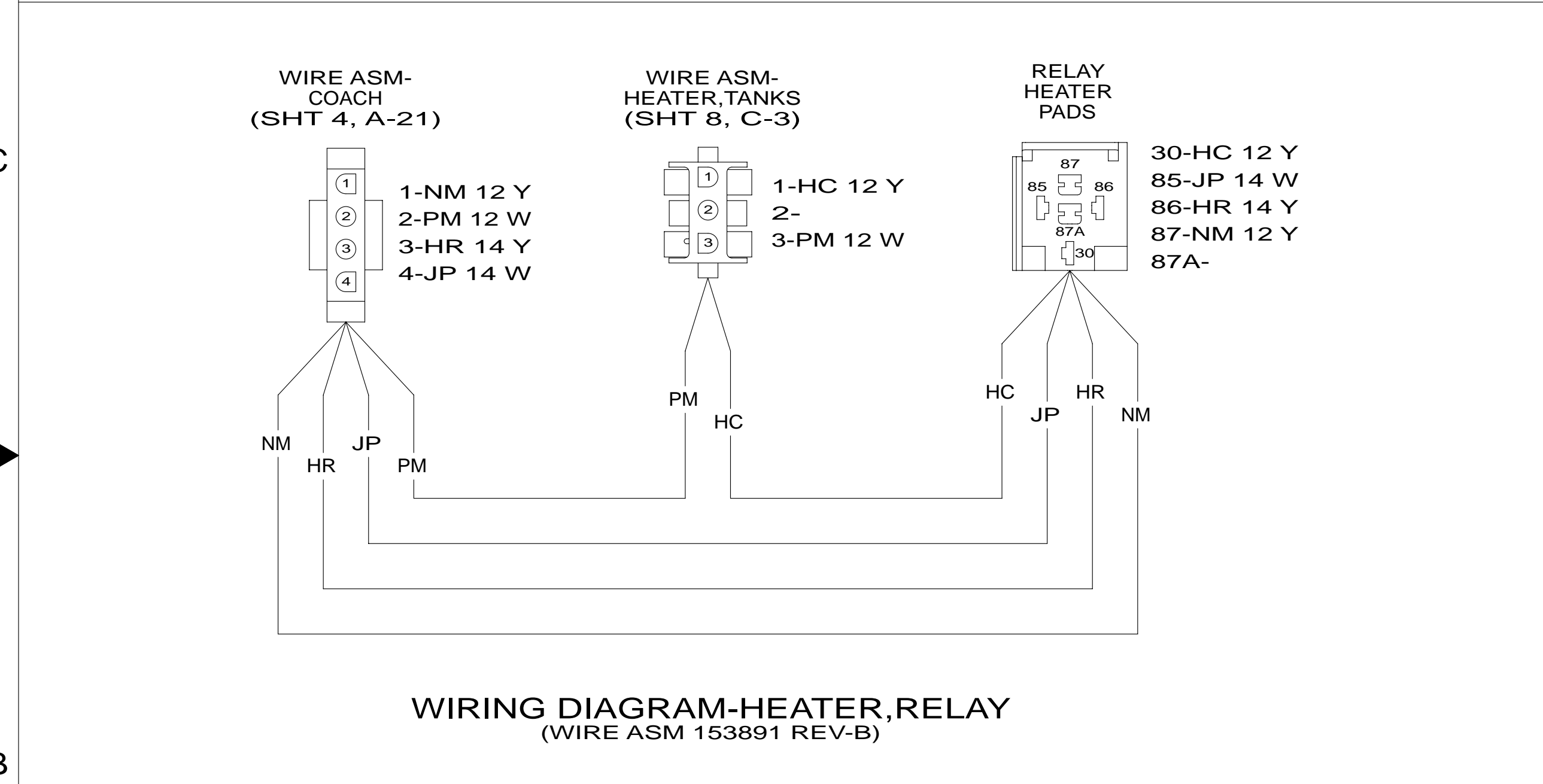
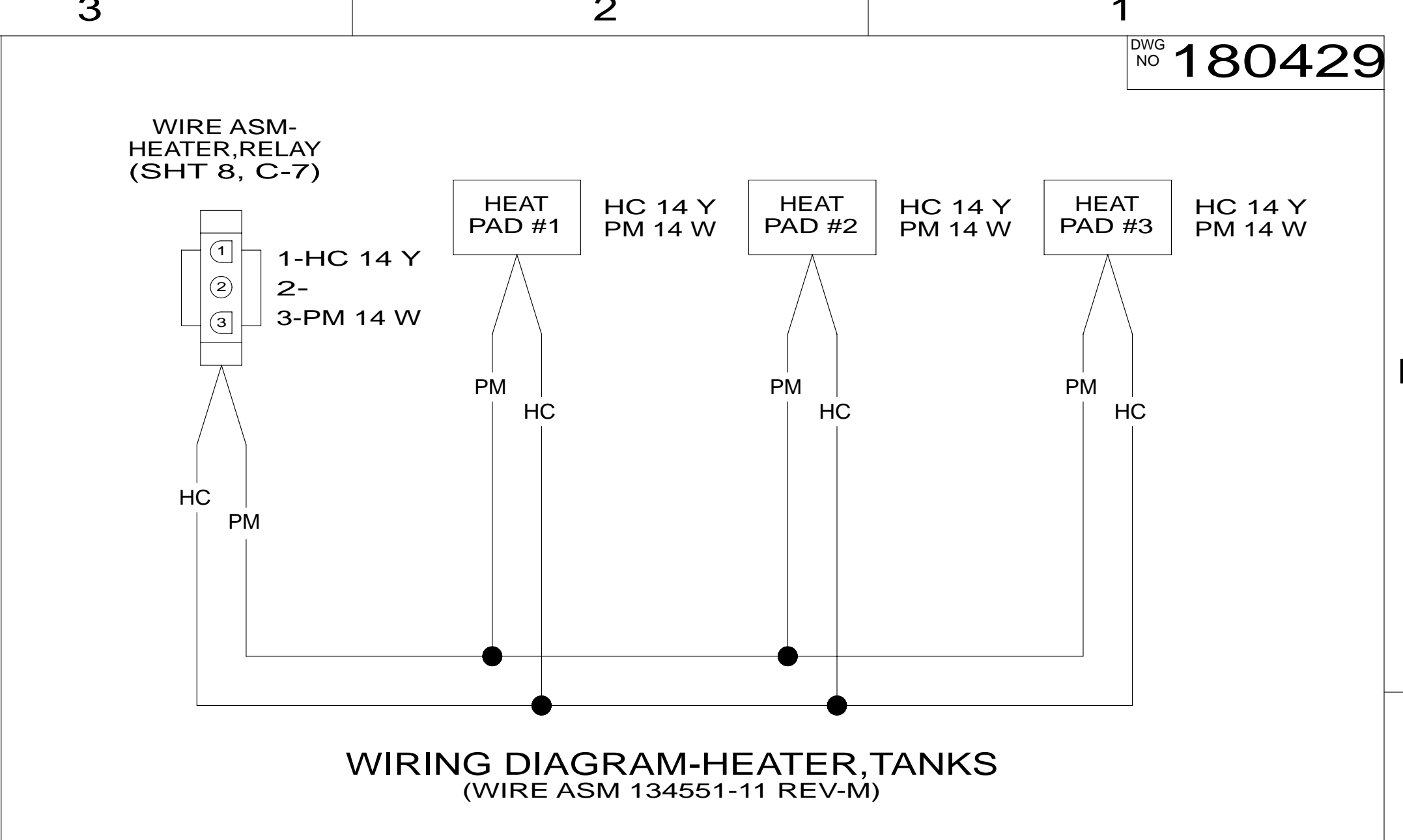
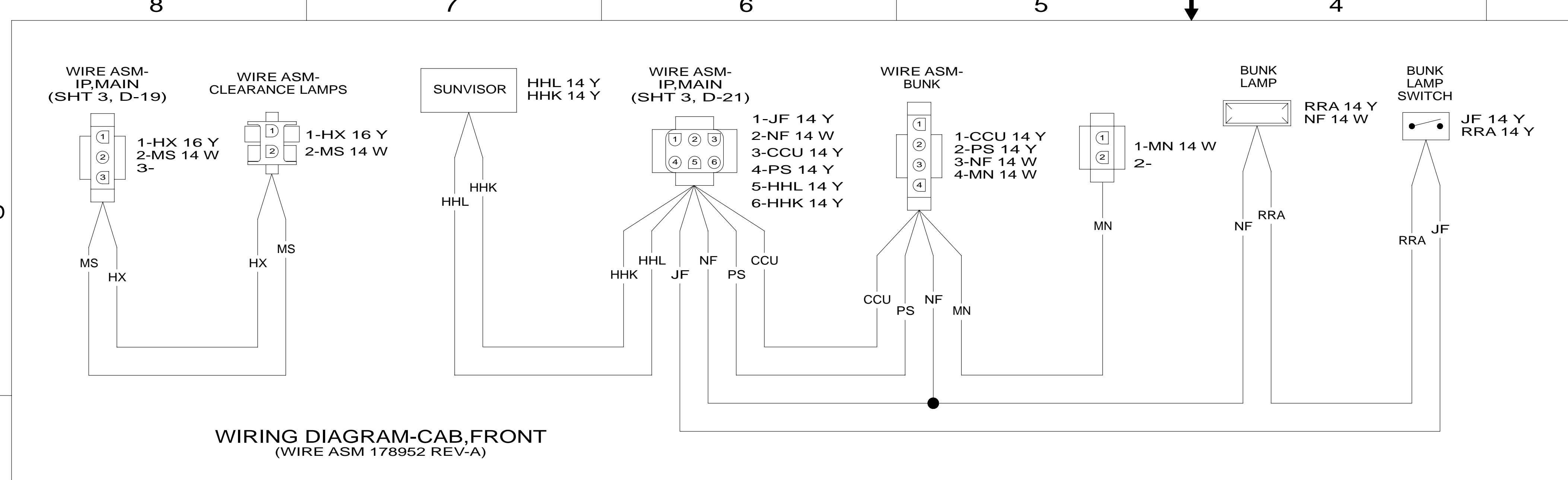

3 GROUND SYMBOL: GROUND ARE SHOWN AS A SINGLE LINE FOR EASE IN TRACING. EACH GROUND CIRCUIT IS SEPERATE IN THE HARNESS.

2 NOT A SPLICE POINT. INDICATES ENTRY INTO WIRING HARNESS.

1 SPLICES ARE THEORETICAL AND MAY DIFFER IN THE HARNESS.

NOTES:

FIRST USED		13 H25T	
DO NOT SCALE DRAWING			
TITLE: WIRING DIAGRAM-BODY,12V			
SHEET 8	PART NO	180429	REV
		1	22-Aug-2012