



DANGER

Danger of electrical shock, burns or death. Always remove all power sources before attempting any repair, service or diagnostic work. Power can be present from shore power, generator, inverter or battery. All power sources must be disabled and secured before performing any service.



CAUTION

If you lack the skills, tools or equipment to perform diagnostic or repair work leave such work to an authorized Winnebago Industries dealer or other qualified shop.

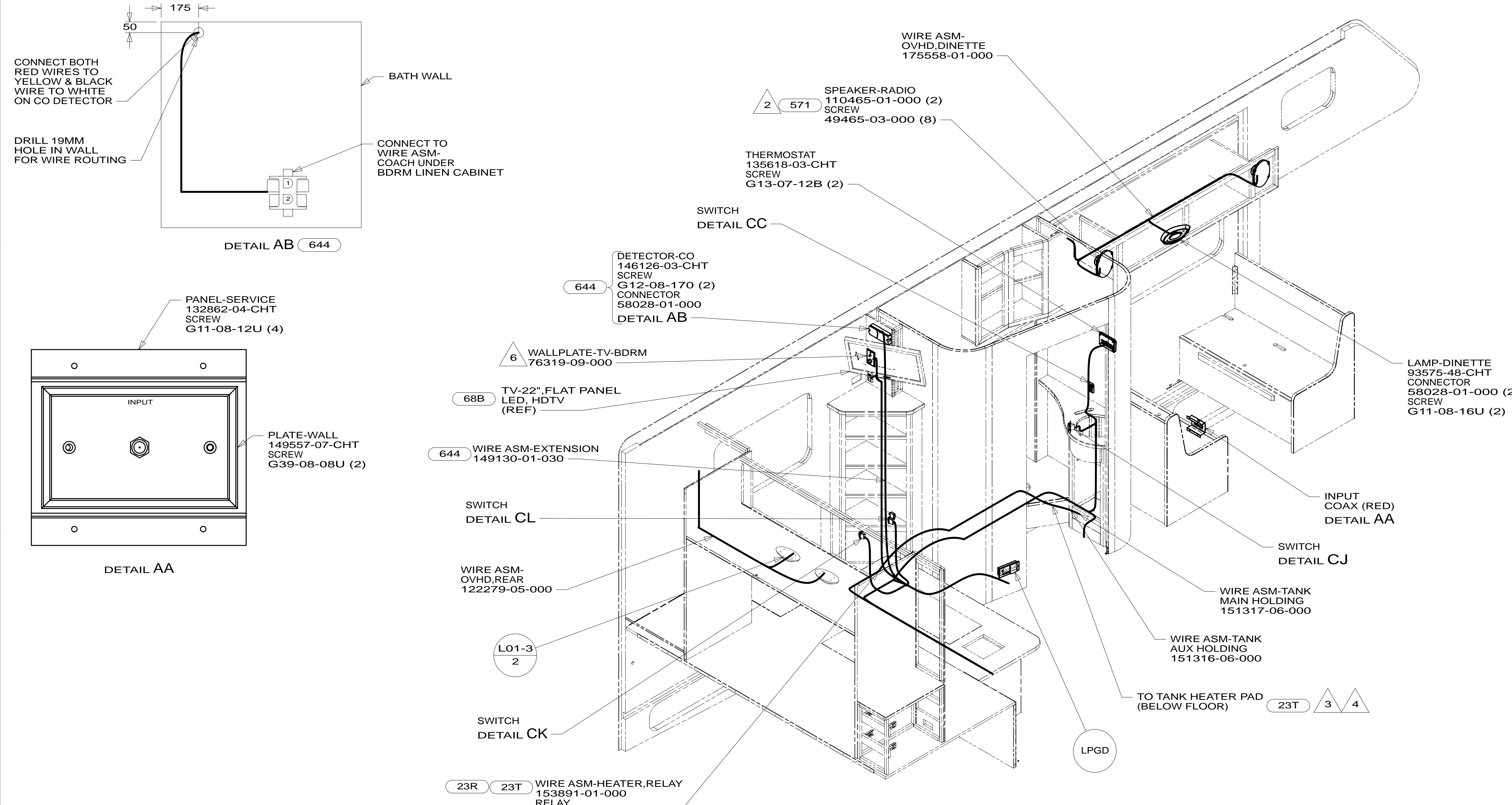

- 6 NOT USED WITH 1MQ
- 5 WIRE ROUTED ALONG DRAINAGE PIPE.
- 4 SEE DRAINAGE SYSTEM INSTALLATION FOR ADDITIONAL INFORMATION.
- 3 WIRE ROUTED ALONG DRAINAGE PIPE AND CONNECTED TO PIPE WITH TIE-WIRE 8343-04-000.
- 2 USE ONE OF THE 4 SPEAKER ASM'S PROVIDED IN KIT. SEND SCREW IN THE KIT TO THE SURPLUS STORE TO BE SOLD. SEND THE WIRE ASM W/HSG TO WIRE PREP TO BE INCORPORATED INTO THE NECESSARY WIRE LOOM.

1. ROUTE TANK SENSOR WIRES SO THEY DO NOT PASS OVER SENSORS. USE WIRE TIE MOUNT 155366-01-000 AND WIRE TIE 8343-01-000 AS NEEDED. TANK SURFACE MUST BE CLEANED USING ISOPROPYL ALCOHOL AND PRIME WITH PRIMER 94.

NOTES:

- 68B TV (REAR) DC 22" LCD W/REMOTE
- 644 GREAT ALASKAN RENTAL PACKAGE
- 571 RADIO SPEAKERS
- 23R DRAINAGE SYSTEM/HEAT-PREWIRE
- 23T DRAINAGE SYSTEM-HEATED
- 265 CODES/STANDARDS-CSA/CMVSS
- 1B1 CODES/STANDARDS USA

		COPYRIGHT 2013 WINNEBAGO INDUSTRIES, INC.
DFTR	ORIG. DATE	
CHKR	ALL DIMENSIONS ARE IN MILLIMETERS	
P.E.		
M.E.	FIRST USED	
DSNR	13 226Q	
UNSPECIFIED TOLERANCES ARE:		MATERIAL:
WHOLE DIM (X)	: 3	
ONE-PLACE (X.X)	: 1.5	
TWO-PLACE (X.XX)	: 0.50	
ANGLE	: 1'	
THIRD ANGLE PROJECTION		
DO NOT SCALE DRAWING	REFER TO ES0018 FOR FASTENER TIGHTENING GUIDELINES	
TITLE: WIRING INSTL-BODY, 12V		
SHEET 1 OF 4	PART NO 180396	REV
REF:	1	17-Apr-2013

FOR ELECTRICAL TORQUE SPECIFICATIONS SEE DWG NO. 128783-01-000

X-X FOR ELECTRICAL CALLOUTS SEE DWG NO. 121339-01-000

* 180396 *

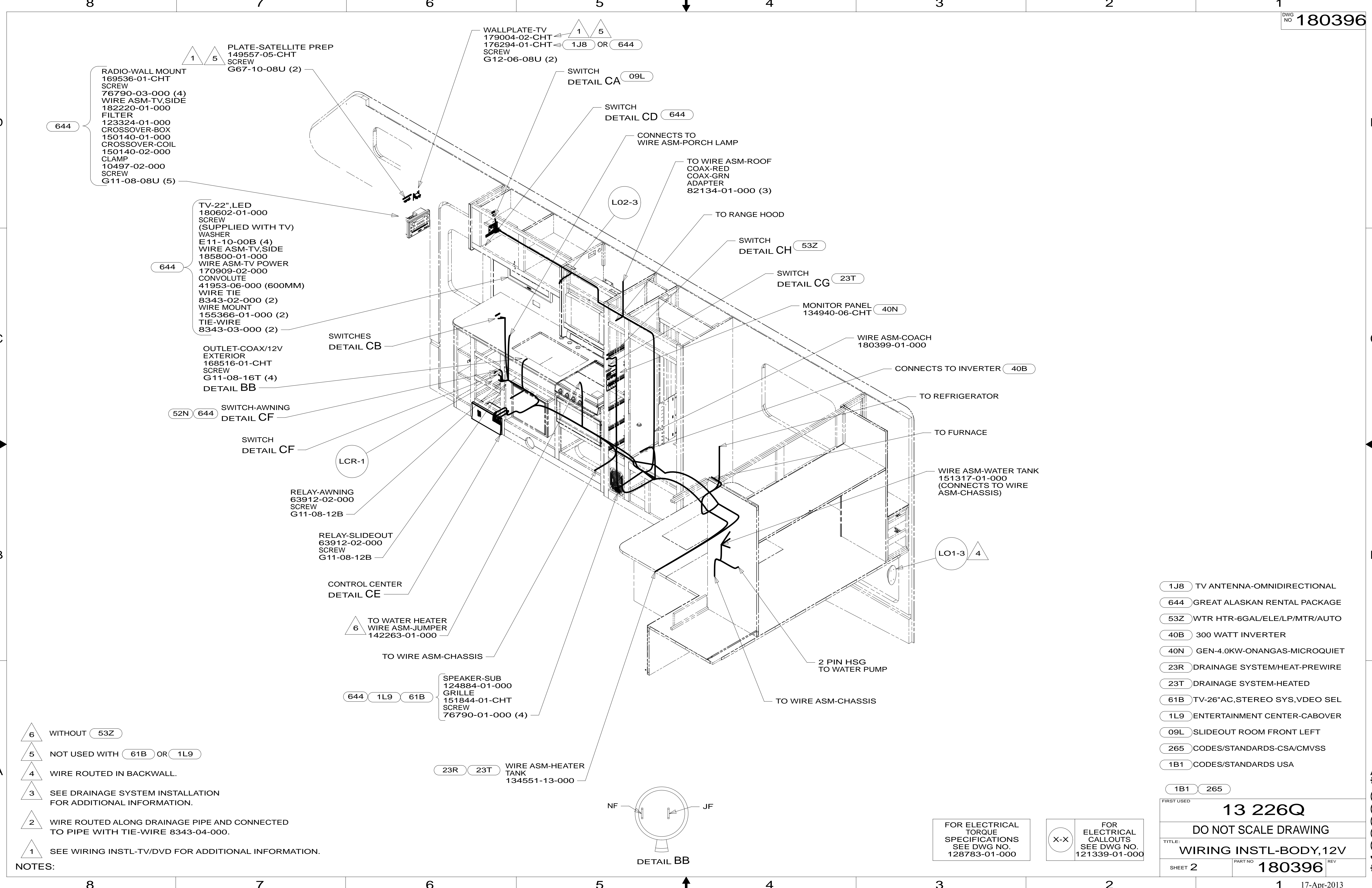

- NOTES:**
- 6 WITHOUT 53Z
 - 5 NOT USED WITH 61B OR 1L9
 - 4 WIRE ROUTED IN BACKWALL.
 - 3 SEE DRAINAGE SYSTEM INSTALLATION FOR ADDITIONAL INFORMATION.
 - 2 WIRE ROUTED ALONG DRAINAGE PIPE AND CONNECTED TO PIPE WITH TIE-WIRE 8343-04-000.
 - 1 SEE WIRING INSTL-TV/DVD FOR ADDITIONAL INFORMATION.

- 1J8 TV ANTENNA-OMNIDIRECTIONAL
- 644 GREAT ALASKAN RENTAL PACKAGE
- 53Z WTR HTR-6GAL/ELE/LP/MTR/AUTO
- 40B 300 WATT INVERTER
- 40N GEN-4.0KW-ONANGAS-MICROQUIET
- 23R DRAINAGE SYSTEM/HEAT-PREWIRE
- 23T DRAINAGE SYSTEM-HEATED
- 61B TV-26"AC,STEREO SYS,VDEO SEL
- 1L9 ENTERTAINMENT CENTER-CABOVER
- 09L SLIDEOUT ROOM FRONT LEFT
- 265 CODES/STANDARDS-CSA/CMVSS
- 1B1 CODES/STANDARDS USA

FIRST USED	13 226Q	
DO NOT SCALE DRAWING		
TITLE: WIRING INSTL-BODY,12V		
SHEET 2	PART NO 180396	REV
		17-Apr-2013

FOR ELECTRICAL TORQUE SPECIFICATIONS SEE DWG NO. 128783-01-000

FOR ELECTRICAL CALLOUTS SEE DWG NO. 121339-01-000

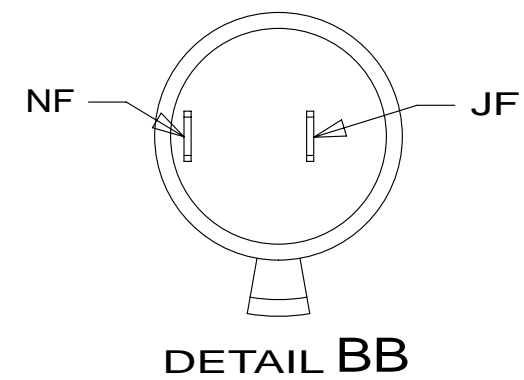

* 180396

DRIVER'S SIDE FRONT
 LABEL-SLIDEOUT, DRIVER, FRONT
 163992-01-CHT

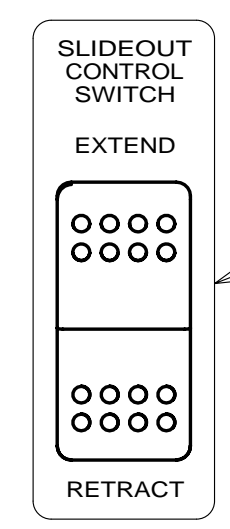
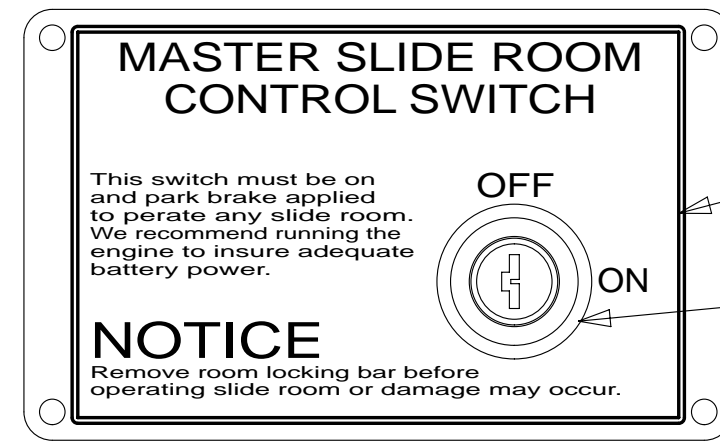

PLATE-SWITCH
 144363-10-CHT
 SWITCH
 108357-06-000
 ACTUATOR
 108356-02-CHT
 NUT
 D65-08-00B (2)
 LABEL
 116220-01-000

PLATE-KEY, SLIDE ROOM
 163987-01-CHT
 SCREW
 76790-05-000 (4)



LABEL-SLIDROOM CONTROL, MAN
 163988-01-CHT

SWITCH-KEY, SPST-ILLINOIS LCK
 163097-01-000
 (CONNECTS TO CIRCUITS DY & DDJ)

WARNING CRUSH HAZARD. Keep people and objects clear of the inside and the outside of the slideout room when operating. Failure to comply could result in death or serious injury.

LABEL-WARNING, SLIDEOUT
 116549-01-000

DETAIL CA

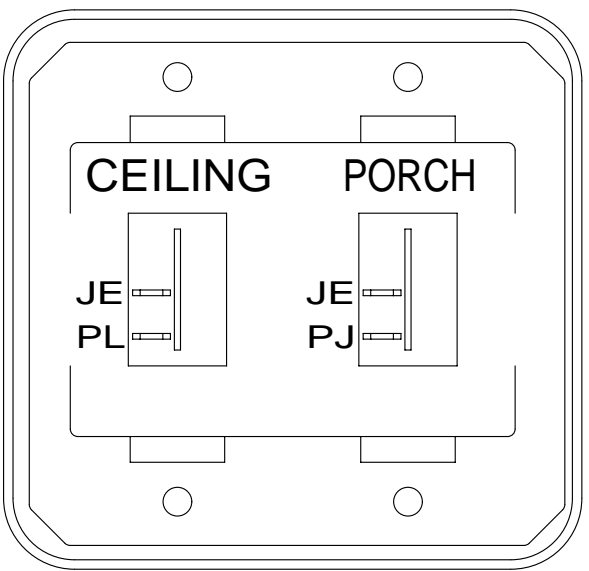

SWITCH-ROCKER
 135740-01-CHT (2)
 SWITCH-BASE
 135741-02-CHT
 SWITCH-BEZEL
 135742-19-CHT
 SCREW
 G11-08-08U (4)

DETAIL CB

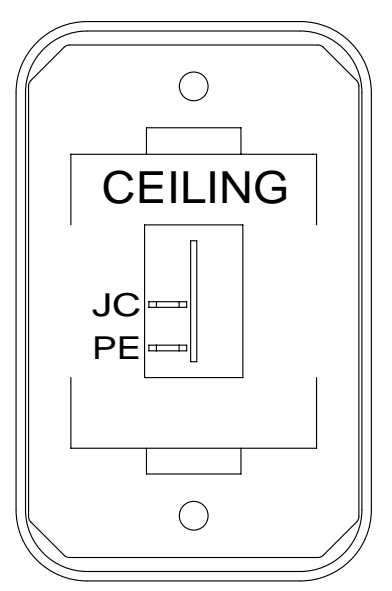

SWITCH-ROCKER
 135740-01-CHT
 SWITCH-BASE
 135741-01-CHT
 SWITCH-BEZEL
 135742-07-CHT
 SCREW
 G11-08-08U (2)

DETAIL CC

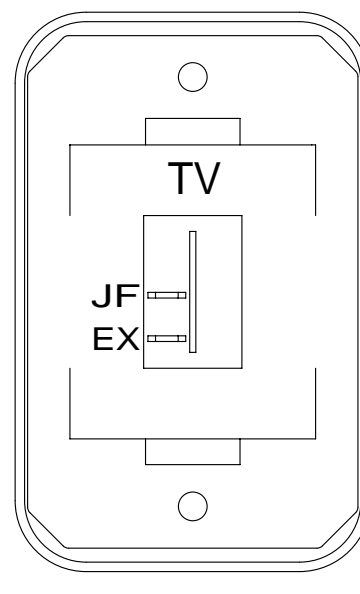

SWITCH-ROCKER
 135740-01-CHT
 SWITCH-BASE
 135741-01-CHT
 SWITCH-BEZEL
 135742-45-CHT
 SCREW
 G11-08-08U (2)

DETAIL CD 644

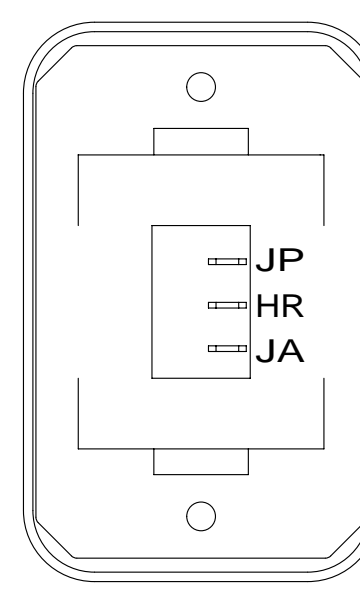

SWITCH-ROCKER
 135740-06-CHT
 SWITCH-BASE
 135741-01-CHT
 SWITCH-BEZEL
 135742-01-CHT
 SCREW
 G11-08-08U (2)
 LABEL-SWITCH
 134563-01-CHT

HOLDING TANK HEATER
 TURN OFF When Not In Use
 SEE OPERATORS MANUAL

DETAIL CG 23T 23R

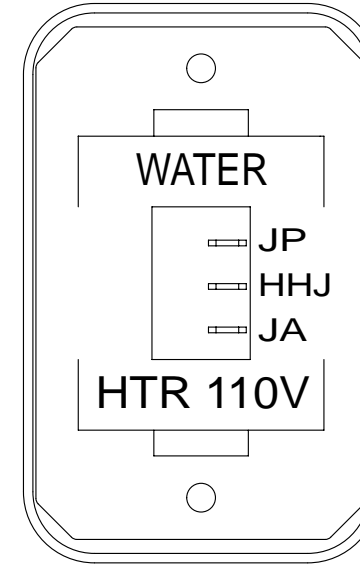

SWITCH-ROCKER
 135740-06-CHT
 SWITCH-BASE
 135741-01-CHT
 SWITCH-BEZEL
 135742-35-CHT
 SCREW
 G11-08-08U (2)

DETAIL CH 53Z

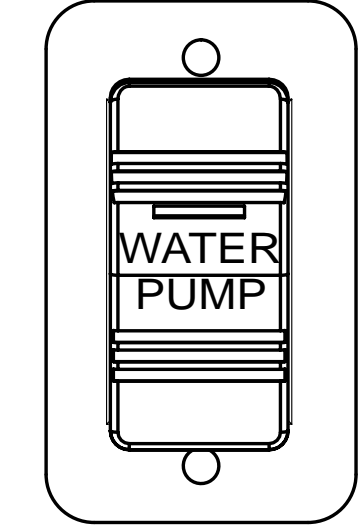

SWITCH-PUMP
 108357-15-000
 ACTUATOR
 108356-23-CHT
 PLATE
 98351-07-CHT
 SCREW
 G11-06-10U (2)

DETAIL CJ

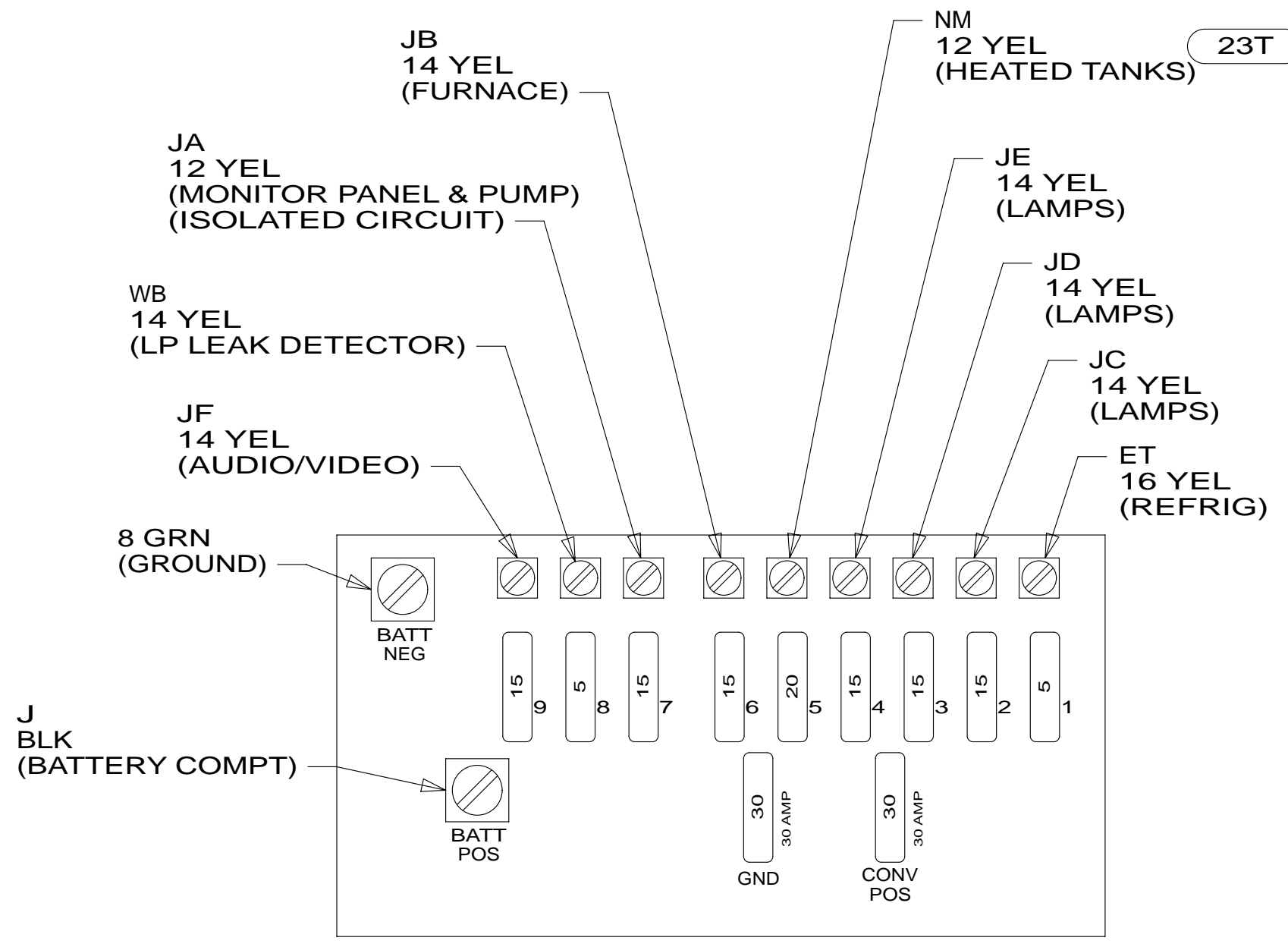

DETAIL CE 1

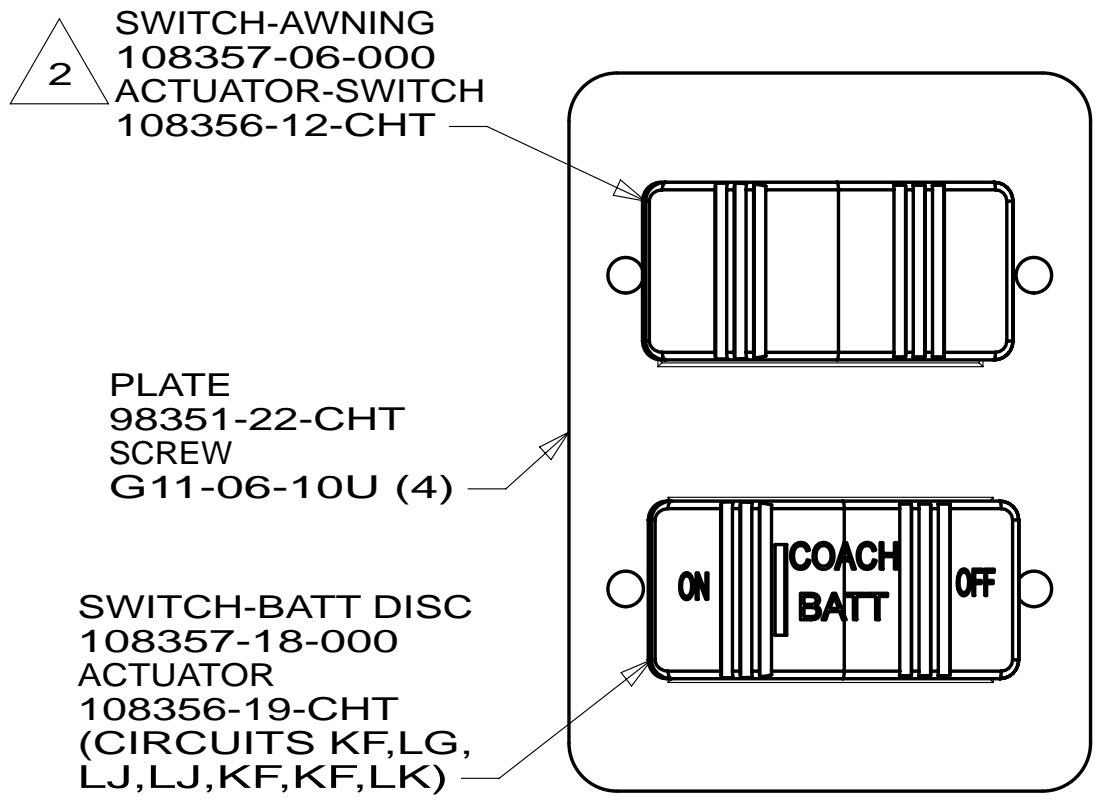

SWITCH-AWNING
 108357-06-000
 ACTUATOR-SWITCH
 108356-12-CHT

PLATE
 98351-22-CHT
 SCREW
 G11-06-10U (4)

SWITCH-BATT DISC
 108357-18-000
 ACTUATOR
 108356-19-CHT
 (CIRCUITS KF, LG, LJ, LJ, KF, KF, LK)

DETAIL CF

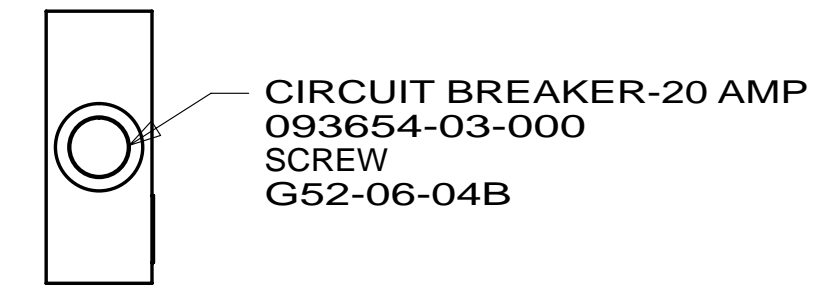

CIRCUIT BREAKER-20 AMP
 093654-03-000
 SCREW
 G52-06-04B

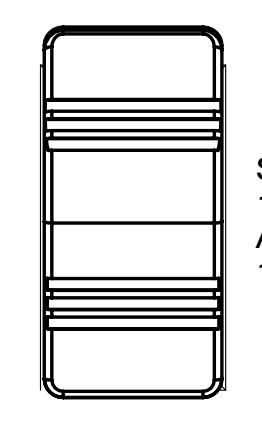

SWITCH-DRAIN PUMP
 108357-09-000
 ACTUATOR
 108356-01-CHT

DETAIL CL

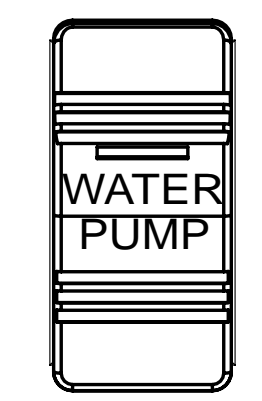

SWITCH-PUMP
 108357-15-000
 ACTUATOR
 108356-23-CHT

DETAIL CK 64R

FOR ELECTRICAL TORQUE SPECIFICATIONS SEE DWG NO. 128783-01-000

FOR ELECTRICAL CALLOUTS SEE DWG NO. 121339-01-000

- 644 GREAT ALASKAN RENTAL PACKAGE
- 64R EXTERIOR WASH STATION
- 52N AWNING - PATIO, ELECTRIC
- 53Z WTR HTR-6GAL/110/LP/MTR/AUTO
- 23R DRAINAGE SYSTEM/HEAT-PREWIRE
- 23T DRAINAGE SYSTEM-HEATED
- 265 CODES/STANDARDS-CSA/CMVSS
- 1B1 CODES/STANDARDS USA

1B1	265
FIRST USED	
13 226Q	
DO NOT SCALE DRAWING	
TITLE: WIRING INSTL-BODY, 12V	
SHEET 3	PART NO 180396 REV

- NOTES:
- 2 INSTALL SWITCH INTO PLATE BUT DO NOT CONNECT THE AWNING WIRES TO THE SWITCH WITH 644
 - 1 FOR REFERENCE ONLY. SEE LOAD CENTER/ATS ASM FOR ADDITIONAL INFORMATION.

SPEAKER-ROUND, CEILING (5) 1L9
 179783-01-CHT
 SCREW
 G1208-12-170 (20)

SPEAKER-ROUND, CEILING (2) 61B 644
 179783-01-CHT
 SCREW
 G1208-12-170 (8)

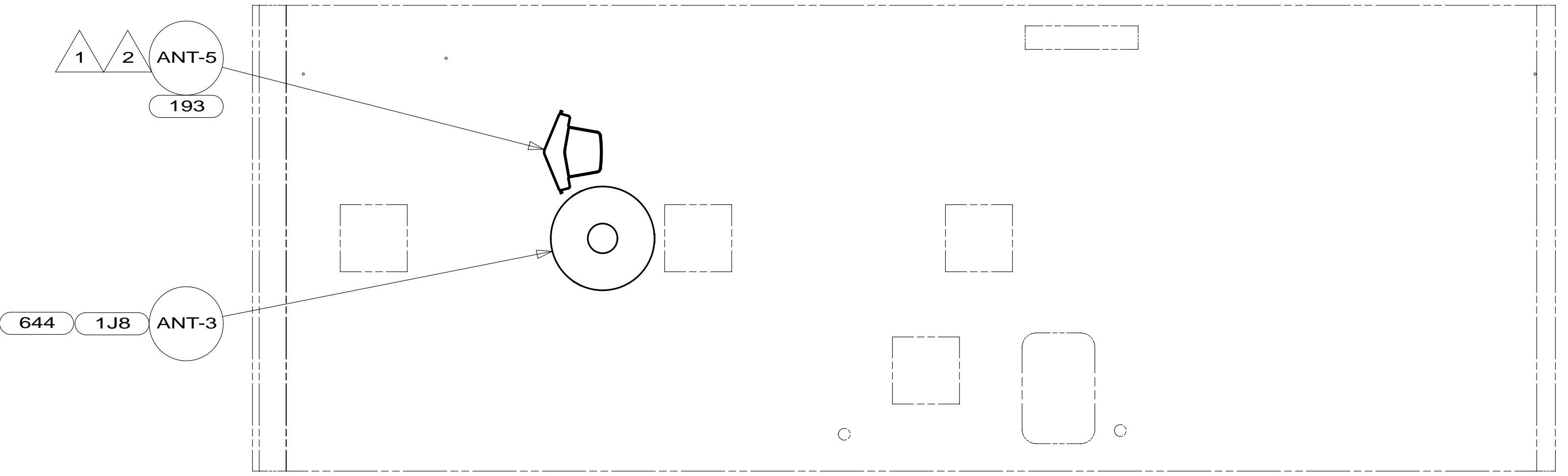
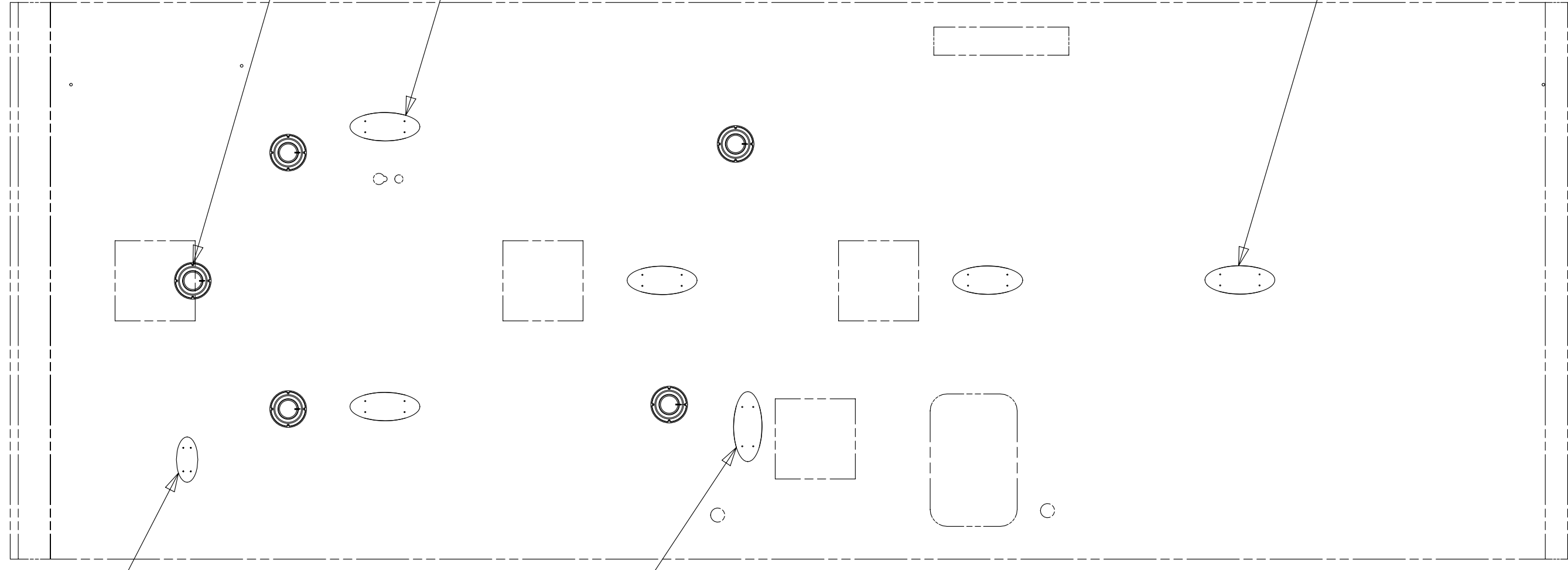
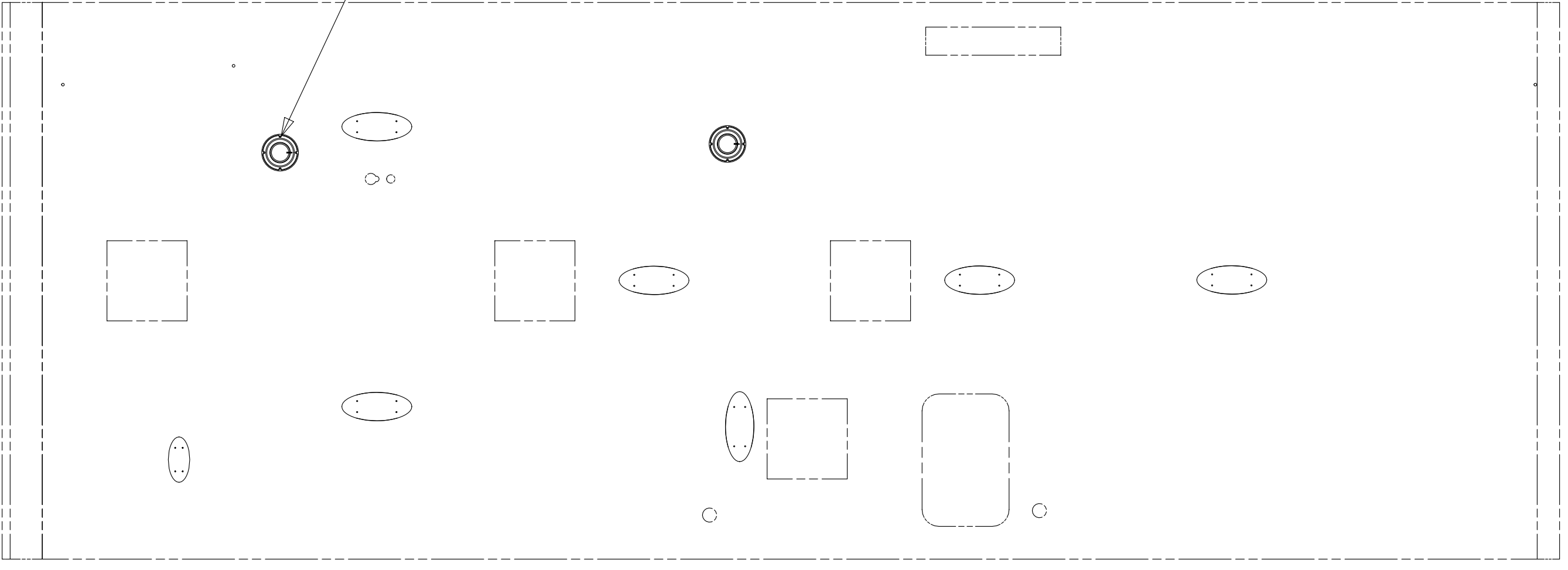

- 644 GREAT ALASKAN RENTAL PACKAGE
- 1L9 ENTERTAINMENT CENTER-CABOVER
- 61B TV-26"AC,STEREO SYS,VDEO SEL
- 193 TV ANTENNA-AMPLIFIED SYSTEM
- 1J8 TV ANTENNA-OMNIDIRECTIONAL
- 265 CODES/STANDARDS-CSA/CMVSS
- 1B1 CODES/STANDARDS USA

- NOTES:
- 3 ADJUST SPEAKER ANGLE TO 0 DEGREES AND TIGHTEN LOCKING SCREW BEFORE MOUNTING TO CEILING
 - 2 SEE DRAWING 76319-01-000 FOR INSTALLATION OF TV ANTENNA.
 - 1 NOT USED WITH 1J8

FOR ELECTRICAL TORQUE SPECIFICATIONS SEE DWG NO. 128783-01-000

FOR ELECTRICAL CALLOUTS SEE DWG NO. 121339-01-000

FIRST USED		13 226Q	
DO NOT SCALE DRAWING			
TITLE: WIRING INSTL-BODY,12V			
SHEET 4	PART NO	180396	REV
		17-Apr-2013	

* 180396 *