



DANGER

Danger of electrical shock, burns or death. Always remove all power sources before attempting any repair, service or diagnostic work. Power can be present from shore power, generator, inverter or battery. All power sources must be disabled and secured before performing any service.



CAUTION

If you lack the skills, tools or equipment to perform diagnostic or repair work leave such work to an authorized Winnebago Industries dealer or other qualified shop.

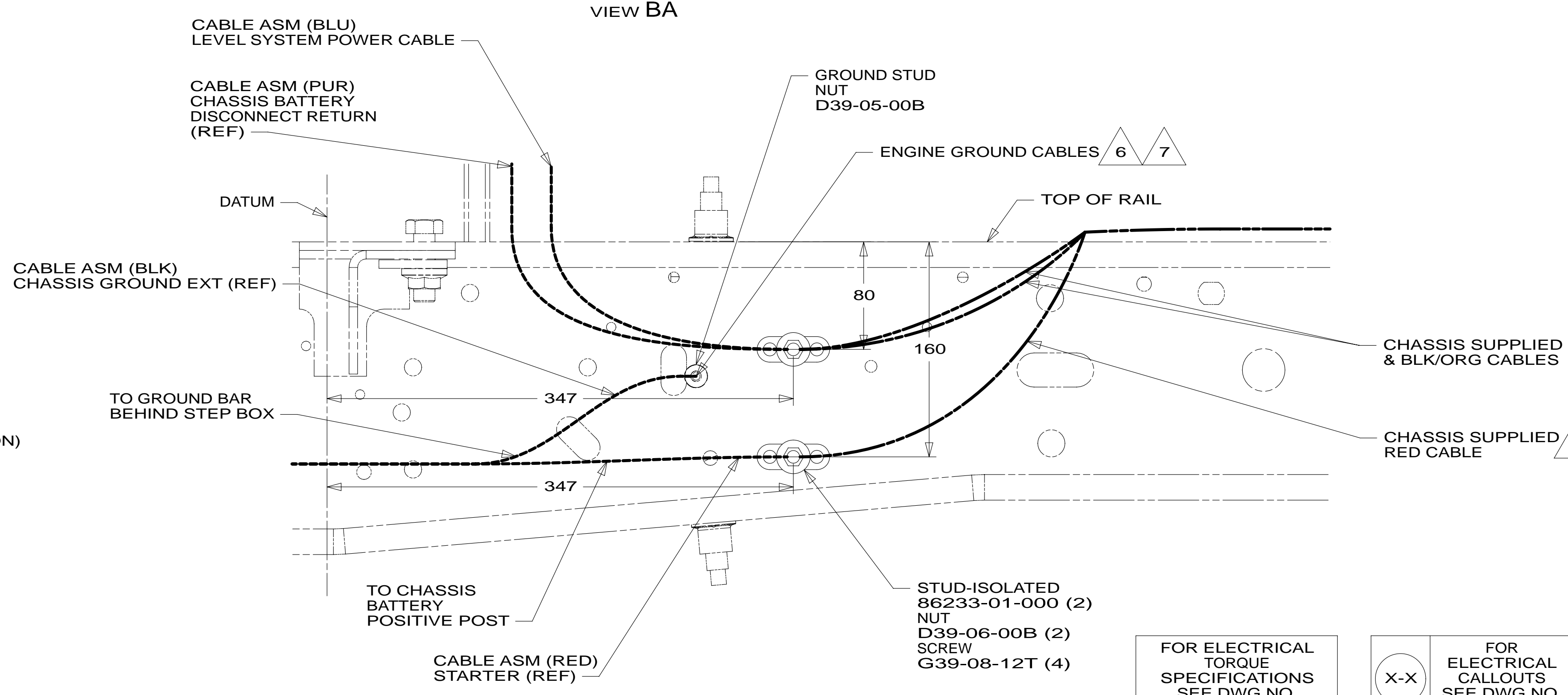
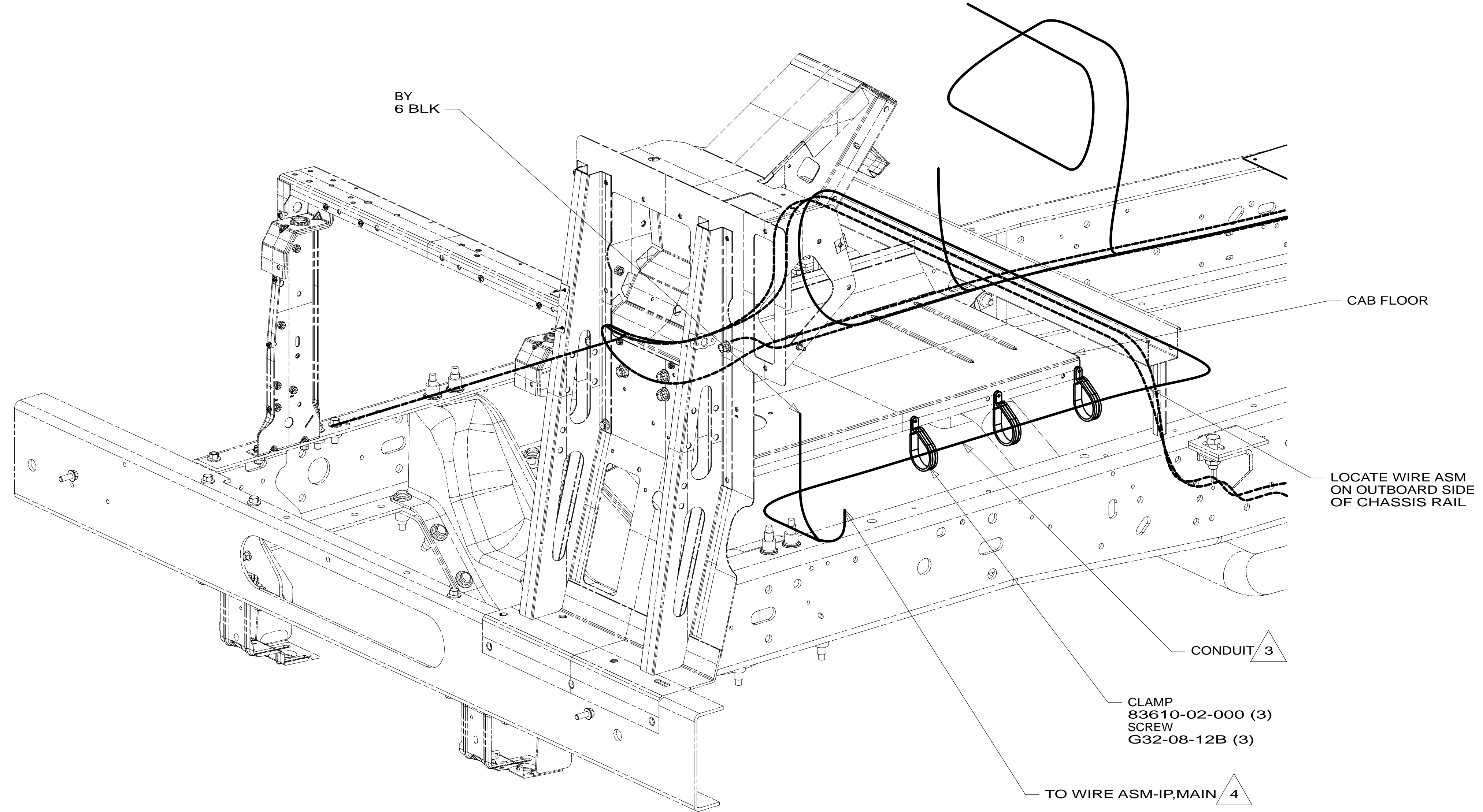

- 8 SEE BATTERY INSTL FOR ADDITIONAL INFORMATION.
- 7 SUPPLIED WITH CHASSIS
- 6 CUT CHASSIS SUPPLIED BATTERY GROUND CABLE 700MM FROM BATTERY TERMINAL AND ADD TERMINAL 8348-01-000 TO CUT END.
- 5 CUT CHASSIS SUPPLIED POSITIVE BATTERY CABLE 150MM FROM BATTERY TERMINAL END, DISCARD TERMINAL END AND SEPARATE WIRES. ADD TERMINAL 8348-01-000 AND HEAT SHRINK 176567-04-000 TO RED CABLE (CHASSIS STARTER) AND COMBINE YELLOW (CHASSIS POWER DISTRIBUTION) AND BLACK/ORANGE (CHASSIS ALTERNATOR) WIRES TOGETHER AND ADD TERMINAL 8348-01-000 AND HEAT SHRINK 176567-02-000. COIL EXCESS CABLE ALONG FRAME RAIL JUST BEHIND RADIATOR AND TIE UP WITH TIE-WIRE 8343-04-000.
- 4 ROUTE WIRE THRU HOLE IN CAB FLOOR.
- 3 COVER WITH CONDUIT 41953-10-000 AND 41953-11-000 AS REQUIRED.

- 2. CONNECT CABLES TO COACH SIDE OF BATTERY DISCONNECT WHEN BATTERY DISCONNECT IS USED.
- 1. CUT OFF EXCESS END OF WIRE TIE.

NOTES:

FOR ELECTRICAL TORQUE SPECIFICATIONS SEE DWG NO. 128783-01-000

FOR ELECTRICAL CALLOUTS SEE DWG NO. 121339-01-000

265	CODES/STANDARDS-CSA/CMVSS
1B1	CODES/STANDARDS USA
1B1	265

FIRST USED	
13 D33C	
DO NOT SCALE DRAWING	
TITLE: WIRING INSTL-CHASSIS	
SHEET 2	PART NO 180334 REV

* 180334 * A

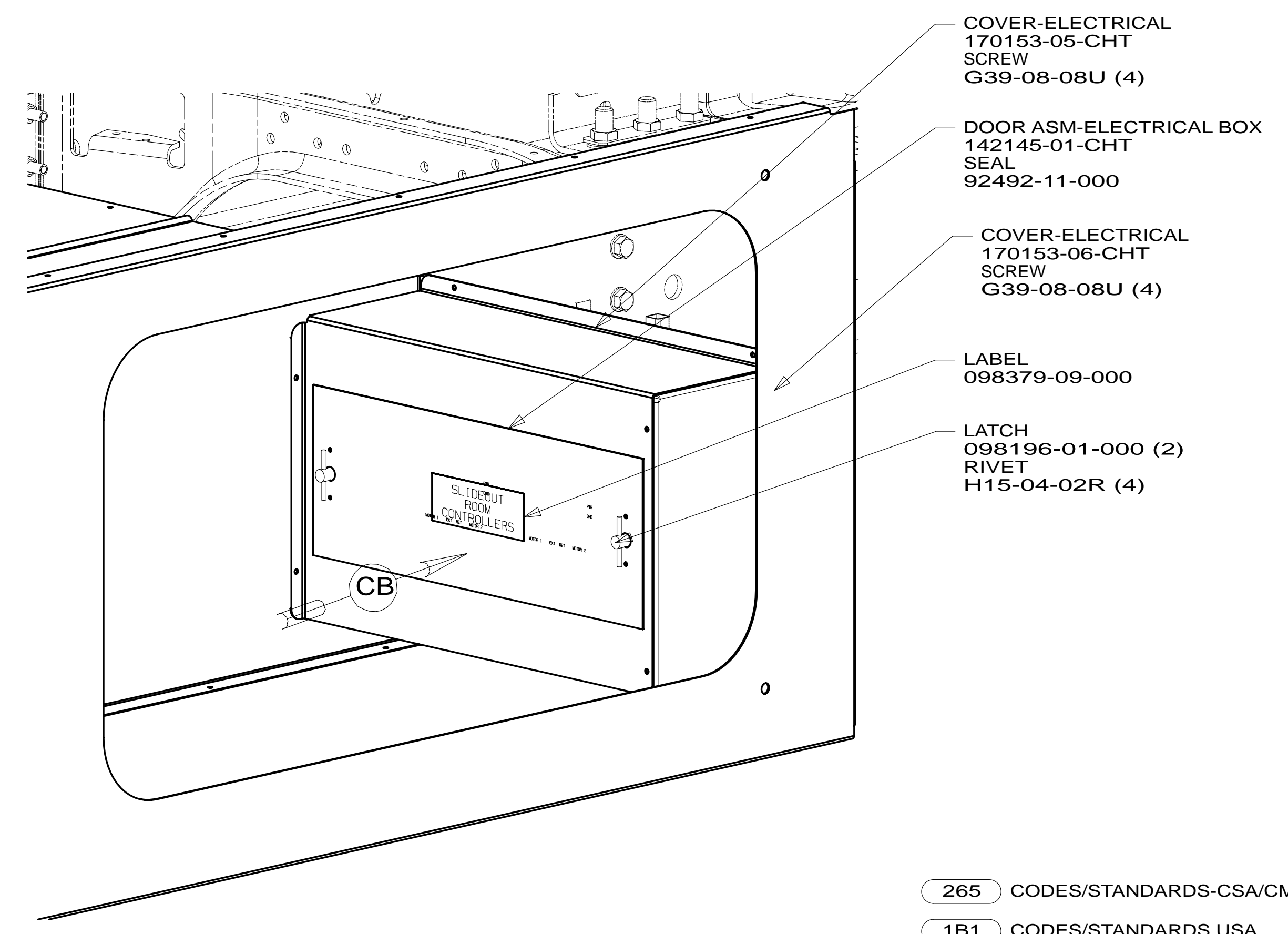
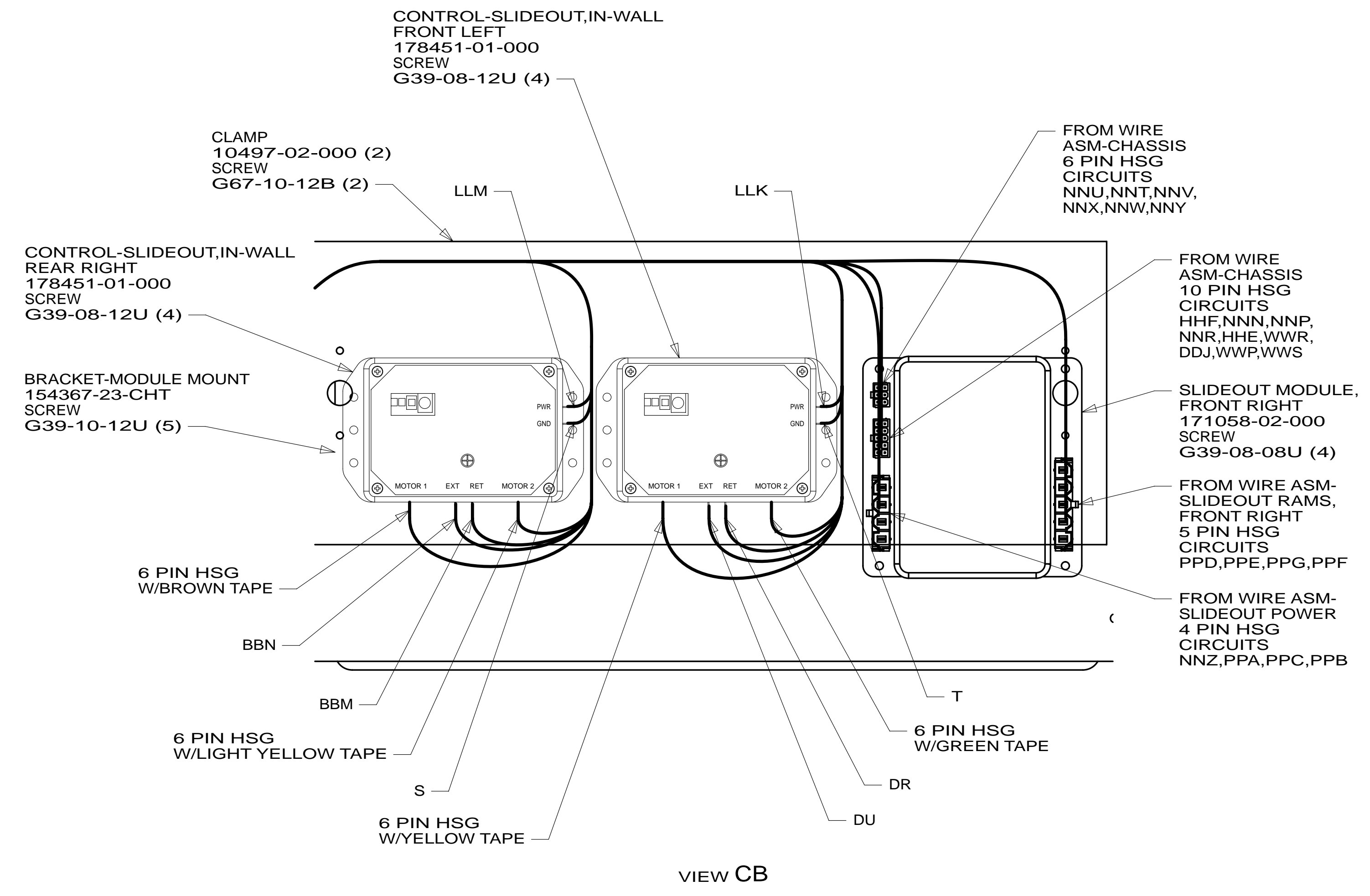
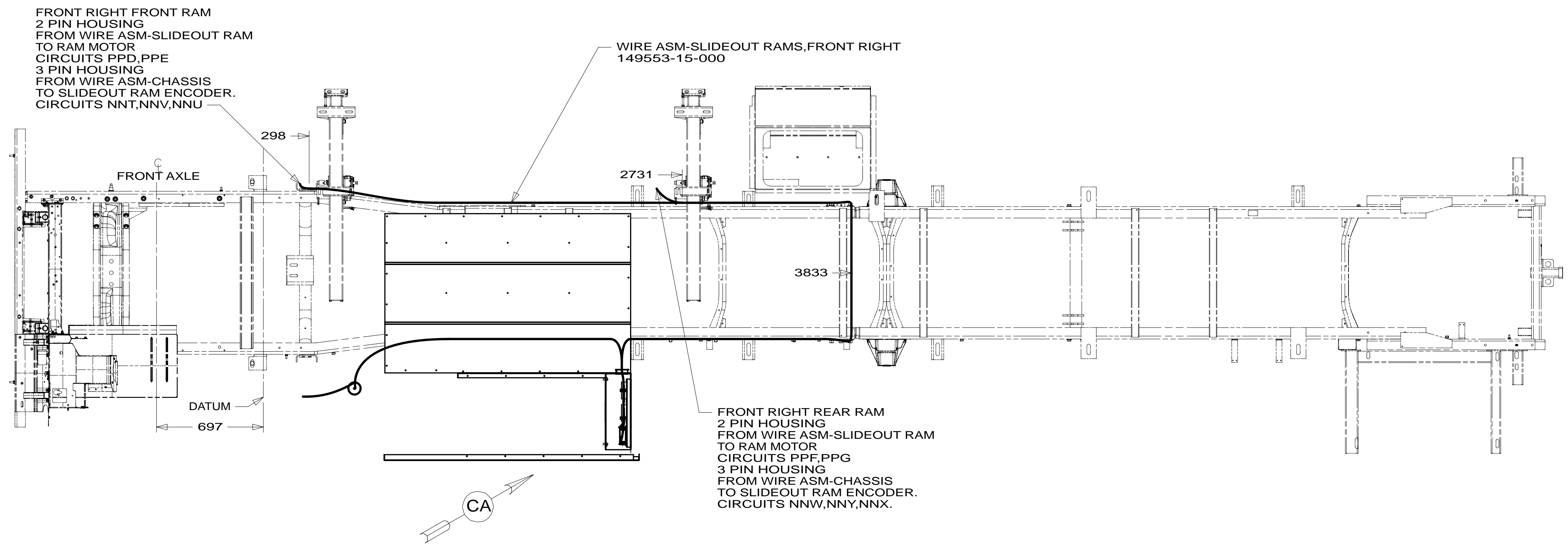

1 SEE CHASSIS ELECTRICAL BOX ASM FOR ADDITIONAL INFORMATION.

FOR ELECTRICAL TORQUE SPECIFICATIONS SEE DWG NO. 128783-01-000

FOR ELECTRICAL CALLOUTS SEE DWG NO. 121339-01-000

265 CODES/STANDARDS-CSA/CMVSS
1B1 CODES/STANDARDS USA

1B1	265
FIRST USED	
13 D33C	
DO NOT SCALE DRAWING	
TITLE: WIRING INSTL-CHASSIS	
SHEET 3	PART NO 180334 REV

* 180334 *