

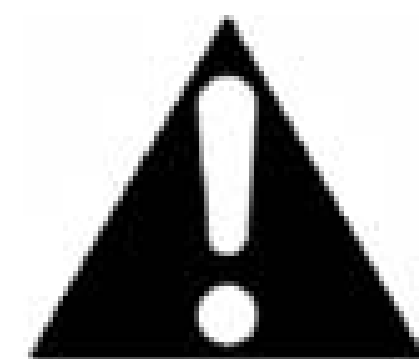

**DANGER**

**Danger of electrical shock, burns or death.** Always remove all power sources before attempting any repair, service or diagnostic work. Power can be present from shore power, generator, inverter or battery. All power sources must be disabled and secured before performing any service.



**CAUTION**

If you lack the skills, tools or equipment to perform diagnostic or repair work leave such work to an authorized Winnebago Industries dealer or other qualified shop.

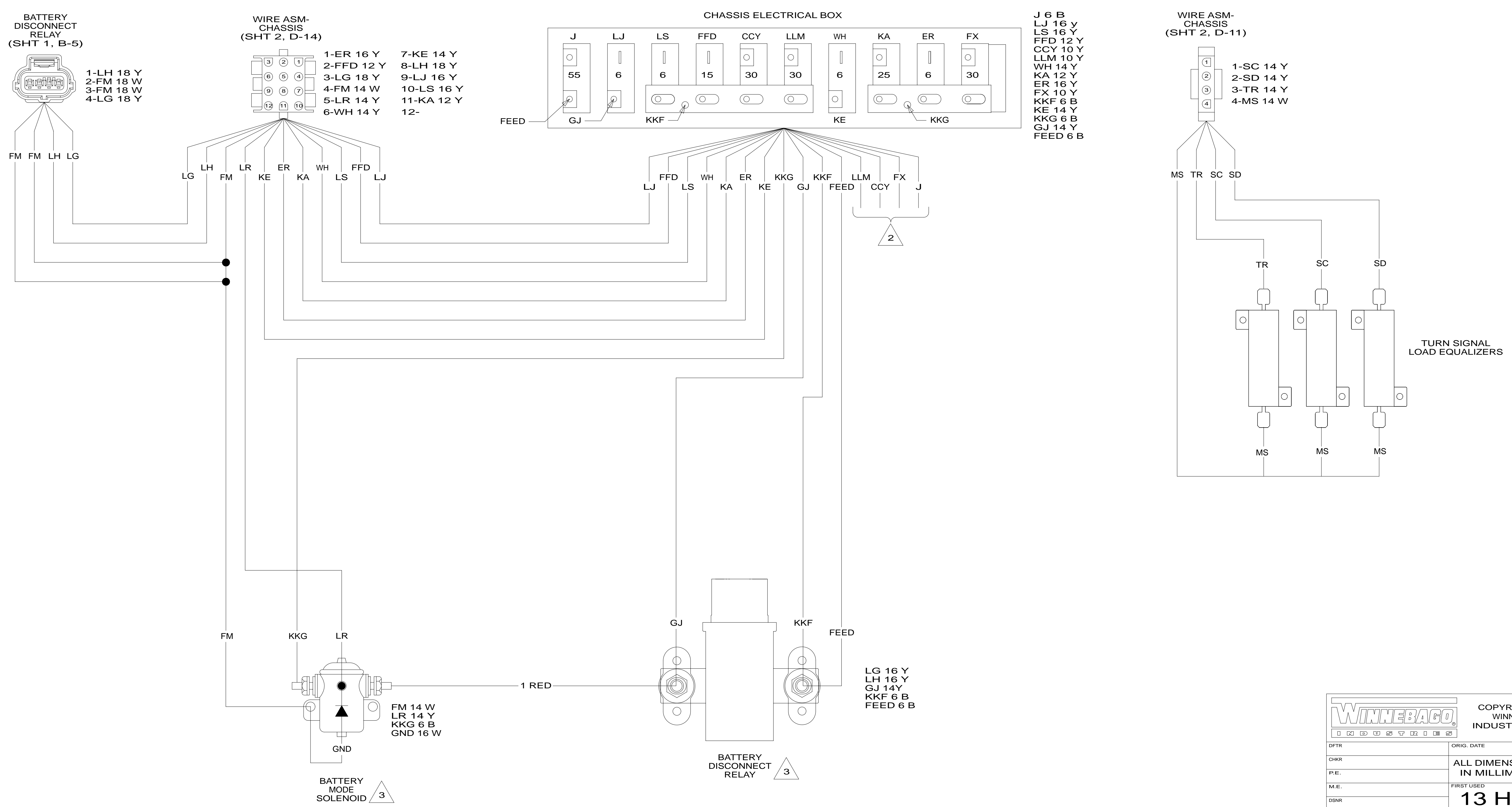

3 SEE MANUFACTURERS DIAGRAM FOR ADDITIONAL INFORMATION.

2 CIRCUIT IS FROM WIRE ASM-CHASSIS.

1. SPLICES ARE THEORETICAL AND MAY DIFFER IN THE HARNESS.

NOTES:

WIRING DIAGRAM-ELECTRICAL BOX  
 (WIRE ASM 124125-15 REV-BR)

<b>WINNEBAGO</b>		COPYRIGHT 2011 WINNEBAGO INDUSTRIES, INC.	
DFTR	ORIG. DATE	ALL DIMENSIONS ARE IN MILLIMETERS	
CHKR		FIRST USED	
P.E.		<b>13 H25Q</b>	
M.E.		MATERIAL:	
DSNR		UNSPECIFIED TOLERANCES ARE:	
		WHOLE DIM (X) :	
		ONE-PLACE (X.X) :	
		TWO-PLACE (X.XX) :	
		ANGLE :	
THIRD ANGLE PROJECTION		DO NOT SCALE DRAWING REFER TO ES0018 FOR FASTENER TIGHTENING GUIDELINES	
TITLE: <b>WIRING DIAGRAM-BODY,12V</b>			
SHEET 1 OF 8	PART NO 180027	REV	
REF:	1	12-Sep-2012	

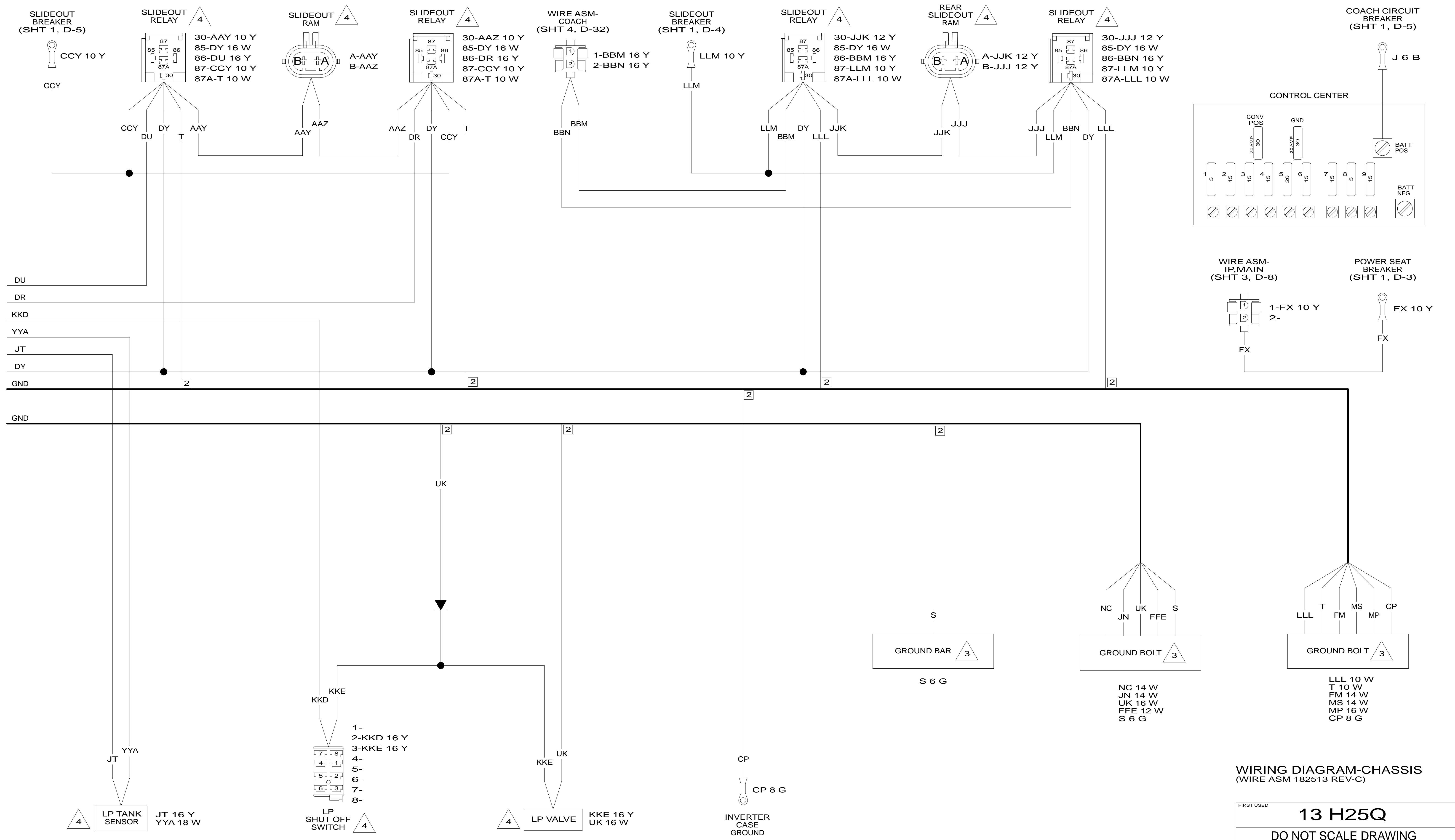

WIRING DIAGRAM-CHASSIS (WIRE ASM 182513 REV-C)

FIRST USED		<b>13 H25Q</b>	
DO NOT SCALE DRAWING			
TITLE: WIRING DIAGRAM-BODY,12V			
F1	SHEET 2	PART NO	<b>180027</b> REV

D

C

B

A

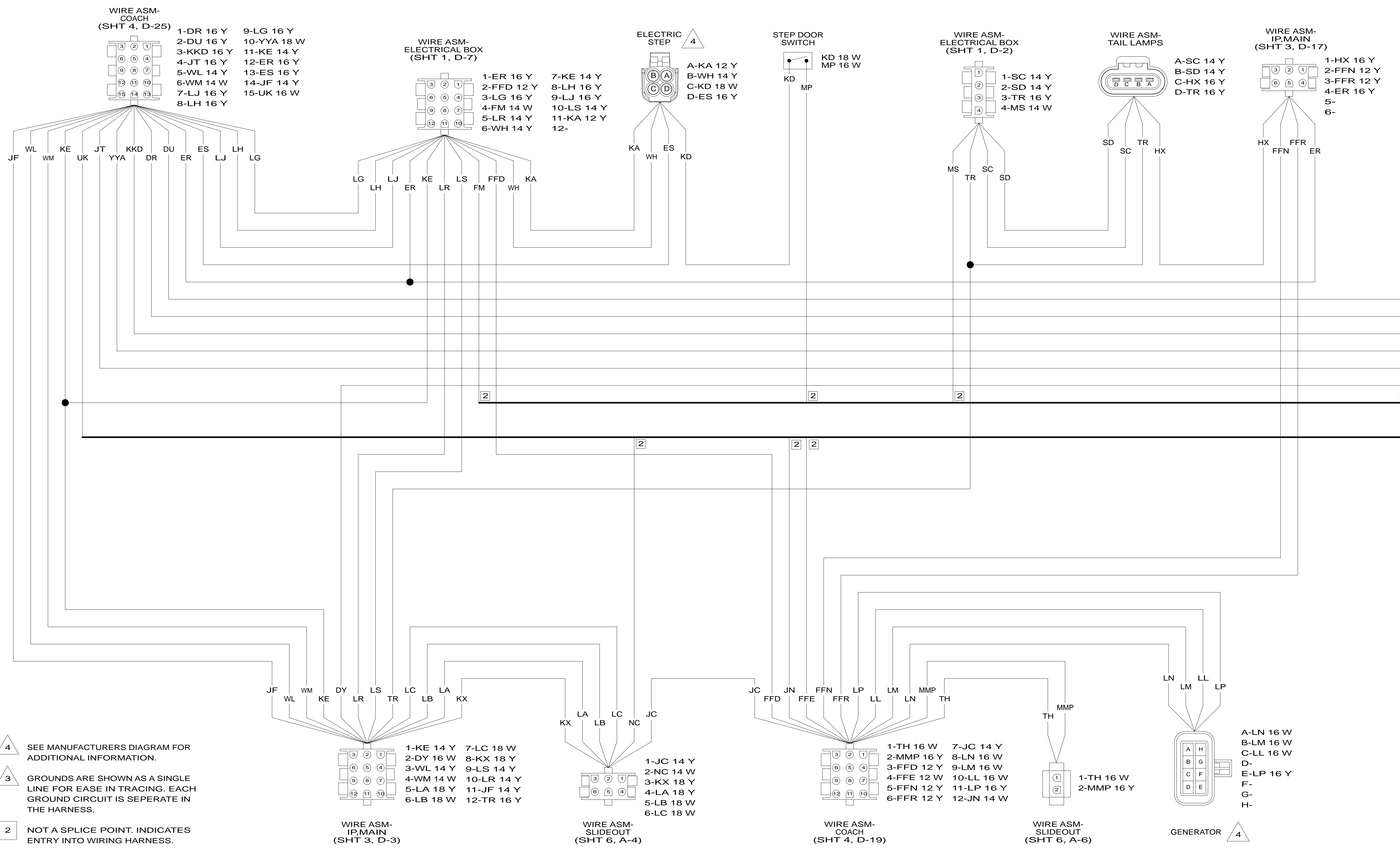

- 4 SEE MANUFACTURERS DIAGRAM FOR ADDITIONAL INFORMATION.
- 3 GROUNDS ARE SHOWN AS A SINGLE LINE FOR EASE IN TRACING. EACH GROUND CIRCUIT IS SEPERATE IN THE HARNESS.
- 2 NOT A SPLICE POINT. INDICATES ENTRY INTO WIRING HARNESS.
1. SPLICES ARE THEORETICAL AND MAY DIFFER IN THE HARNESS.

NOTES:

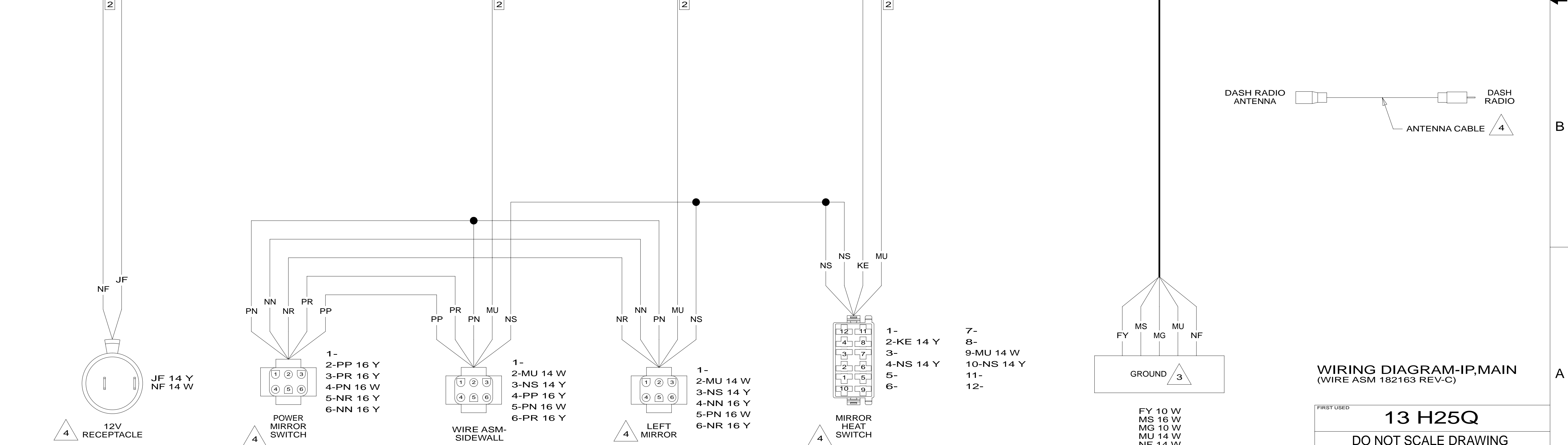
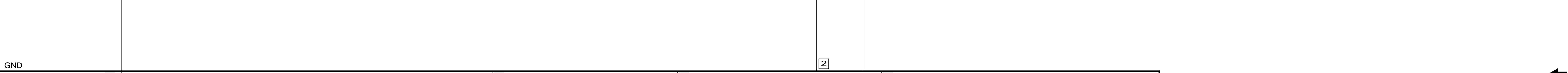
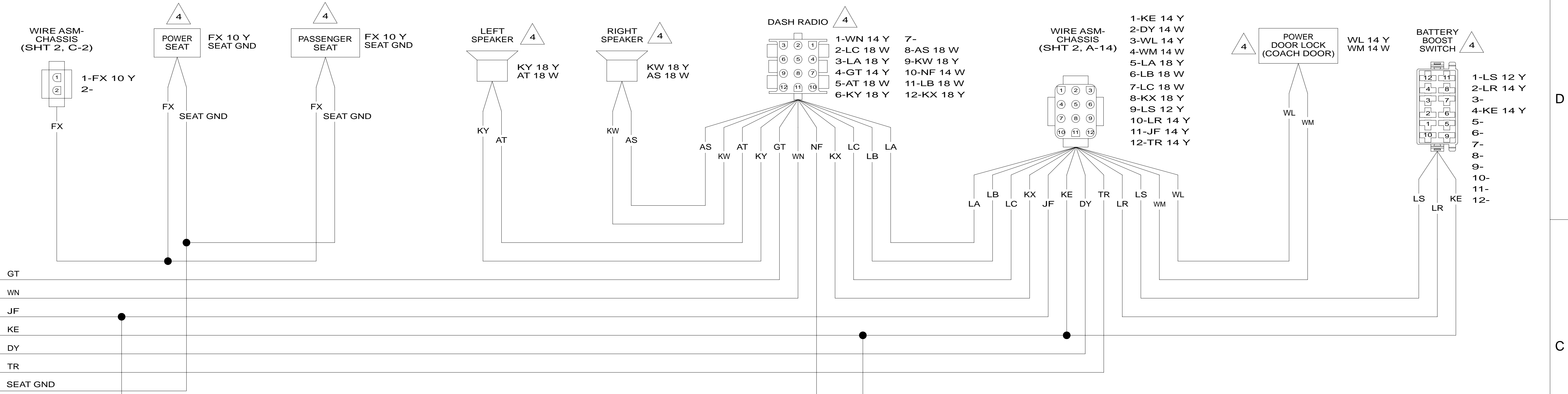

**WIRING DIAGRAM-IP,MAIN**  
(WIRE ASM 182163 REV-C)

FIRST USED **13 H25Q**

DO NOT SCALE DRAWING

TITLE: **WIRING DIAGRAM-BODY,12V**

F1 SHEET 3 PART NO **180027** REV

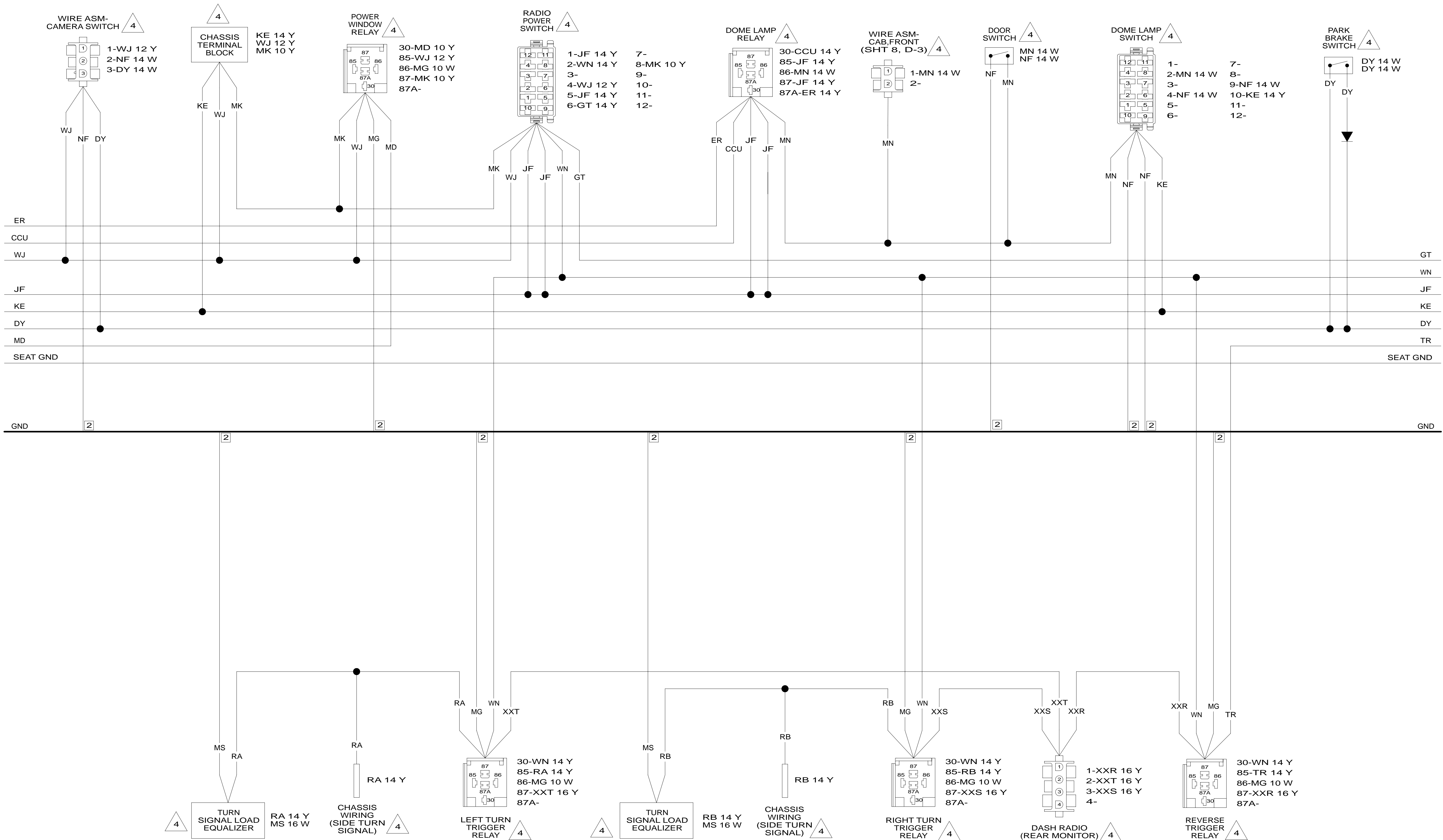

D

C

B

A

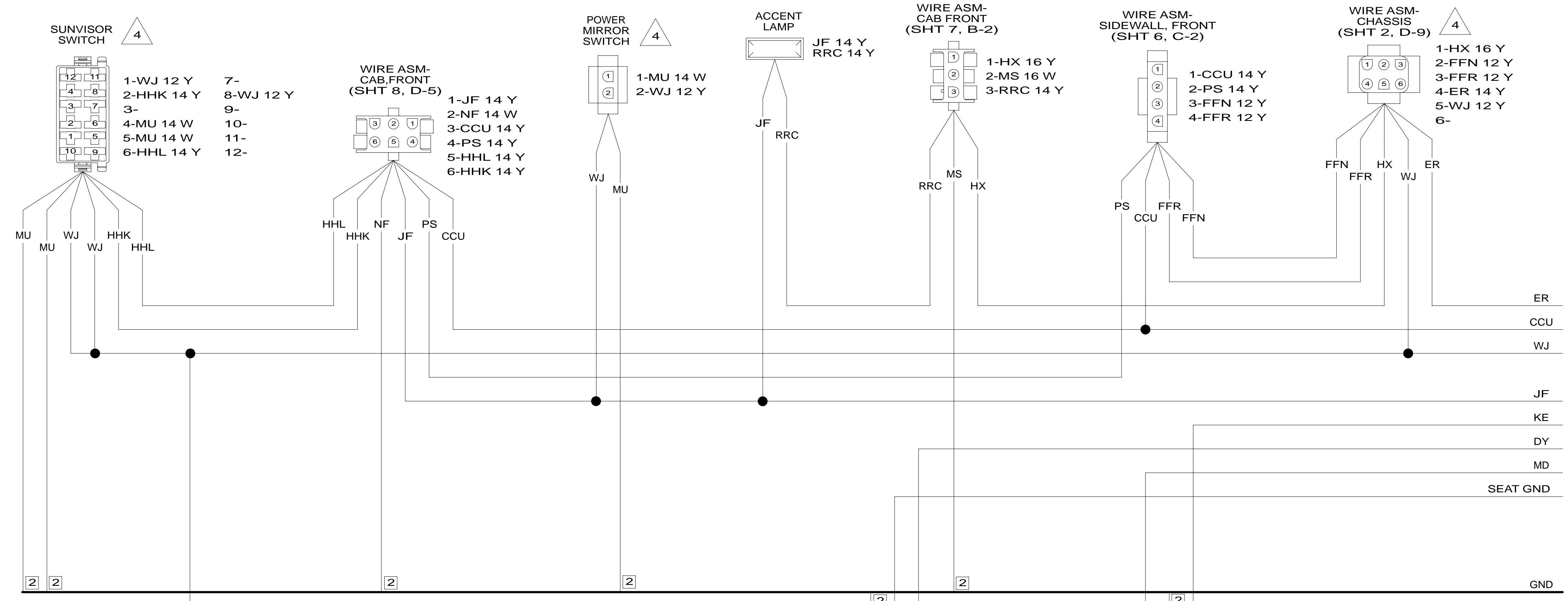

- 4 SEE MANUFACTURERS DIAGRAM FOR ADDITIONAL INFORMATION.
- 3 GROUNDS ARE SHOWN AS A SINGLE LINE FOR EASE IN TRACING. EACH GROUND CIRCUIT IS SEPERATE IN THE HARNESS.
- 2 NOT A SPLICE POINT. INDICATES ENTRY INTO WIRING HARNESS.

1. SPLICES ARE THEORETICAL AND MAY DIFFER IN THE HARNESS.

NOTES:

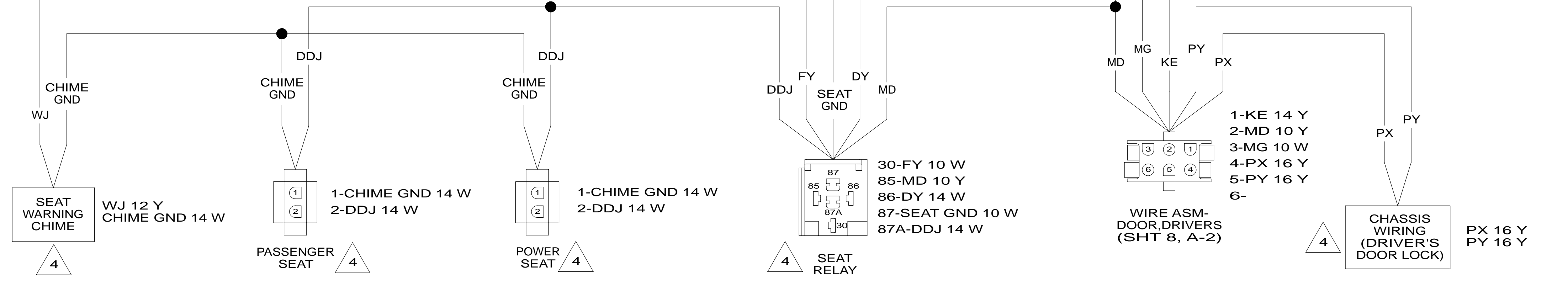

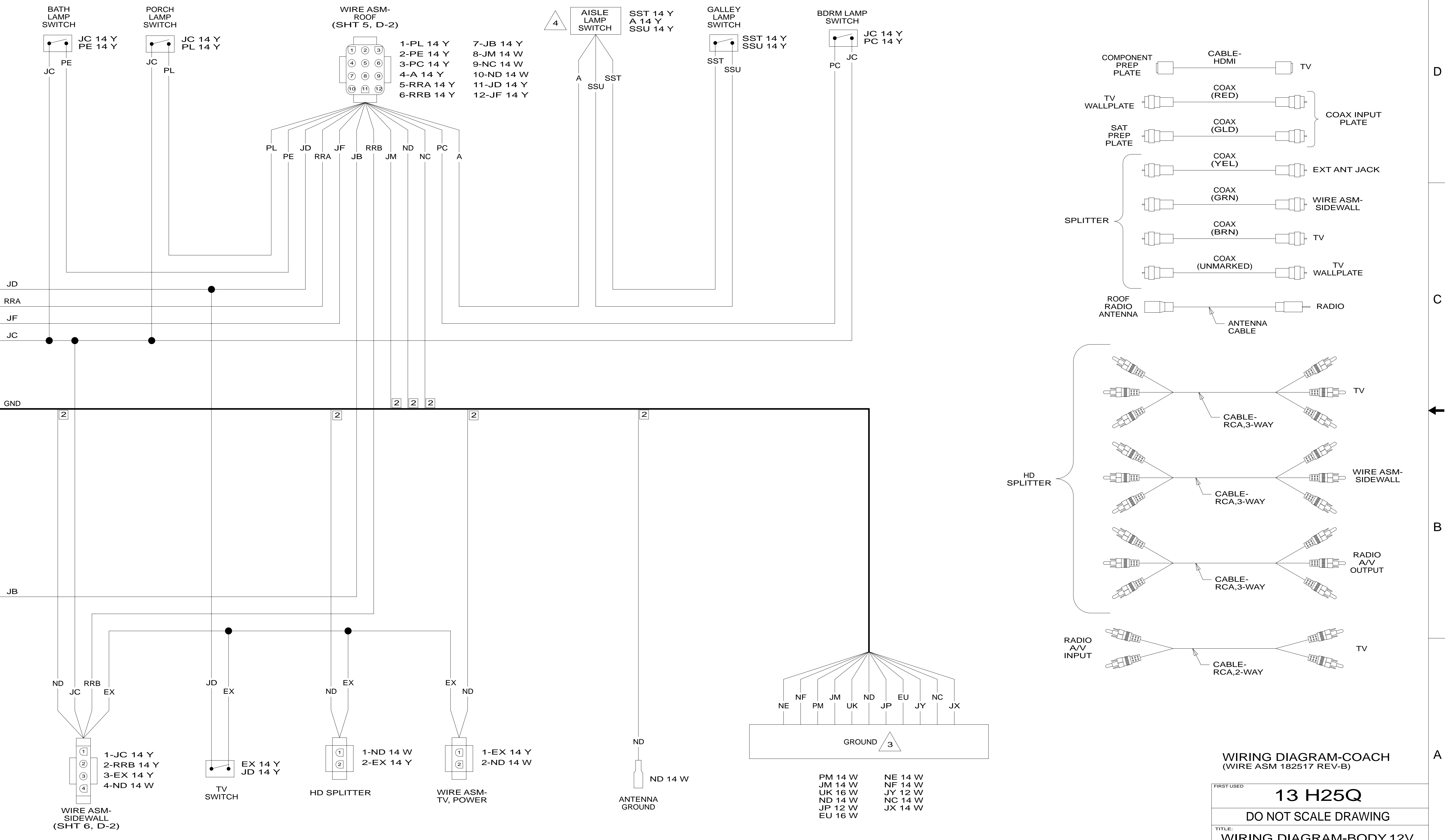

WIRING DIAGRAM-COACH (WIRE ASM 182517 REV-B)

FIRST USED	<b>13 H25Q</b>	
TITLE:	<b>DO NOT SCALE DRAWING</b>	
	<b>WIRING DIAGRAM-BODY, 12V</b>	
F1	SHEET 4	PART NO <b>180027</b> REV



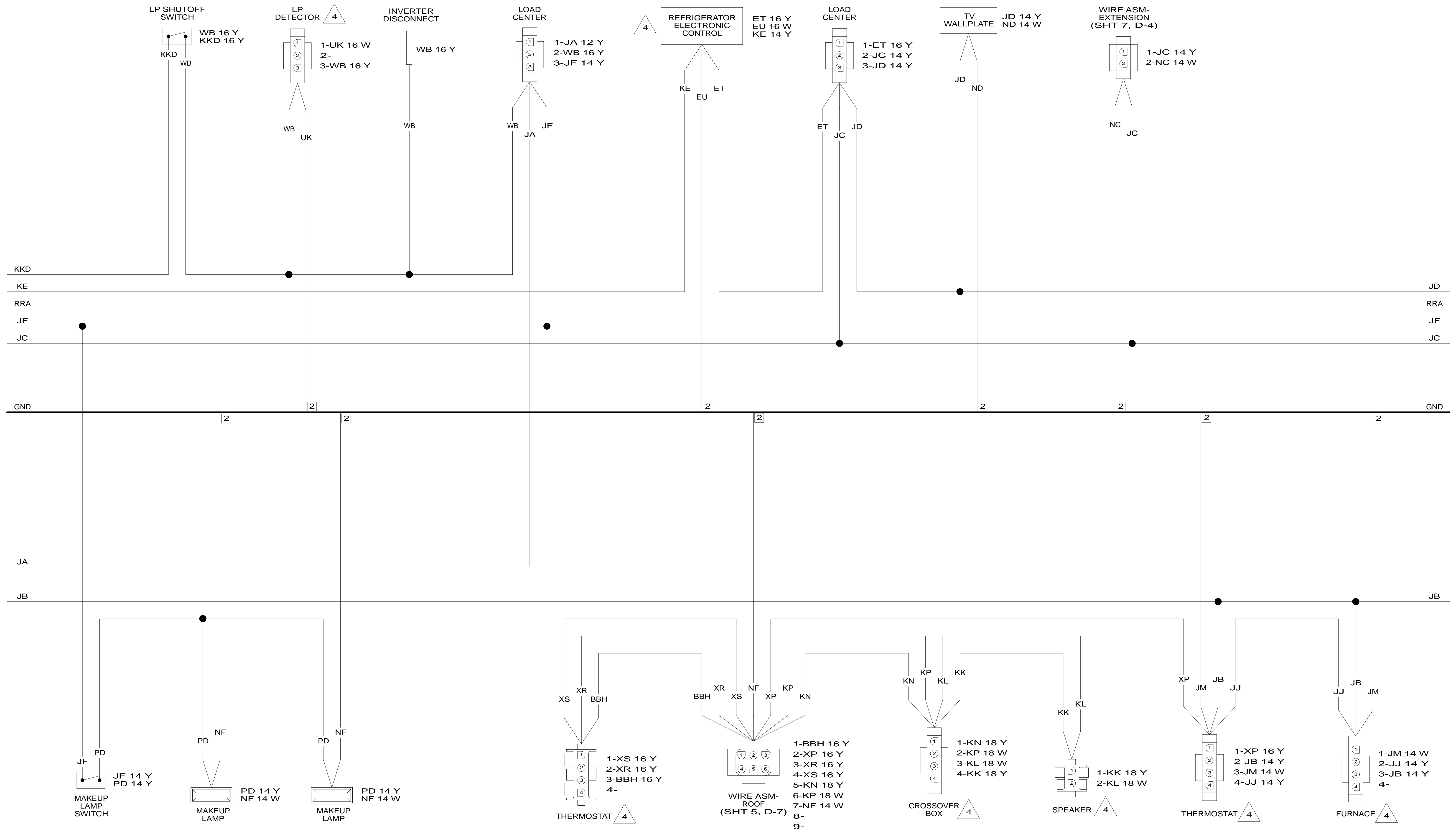

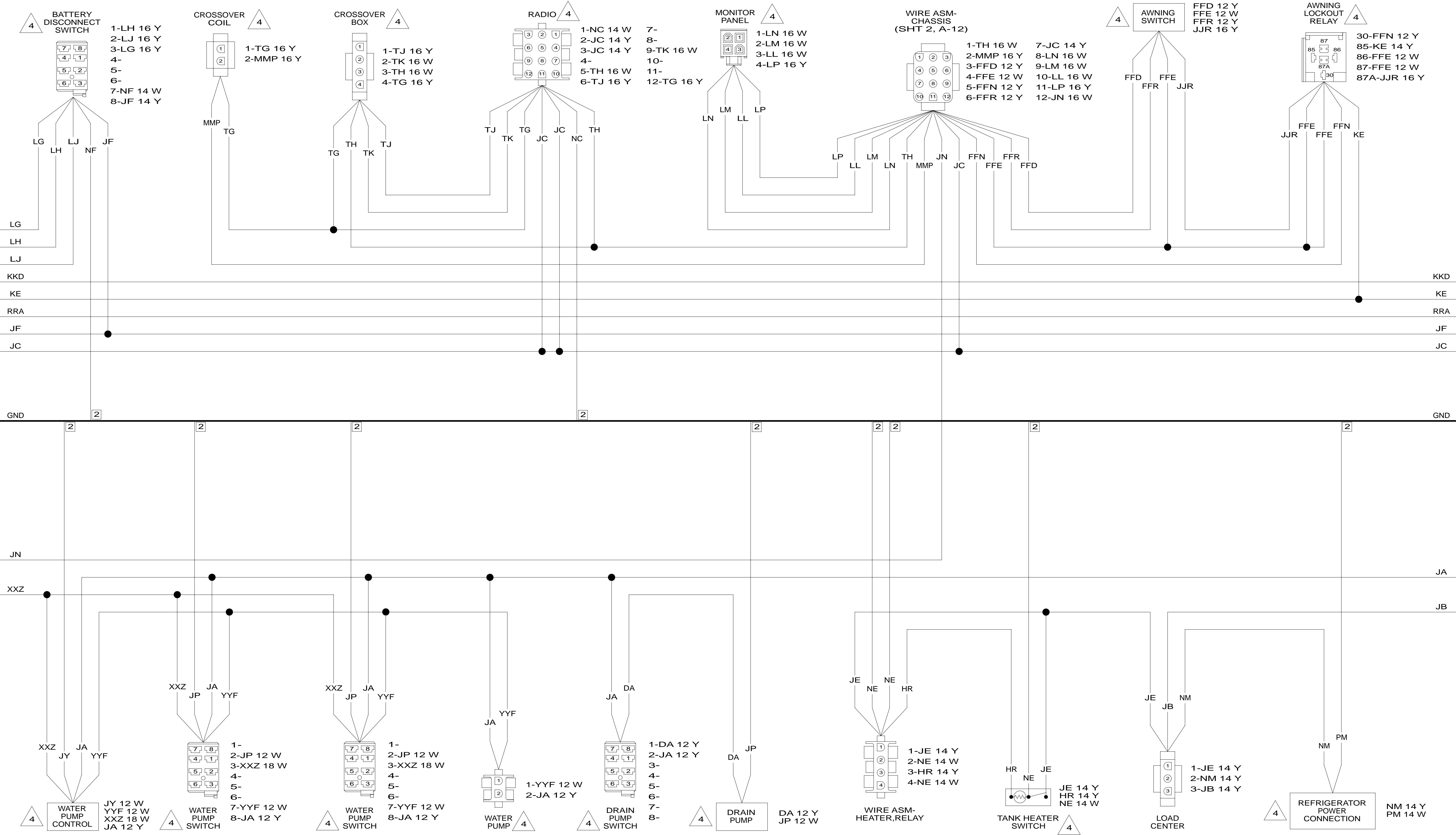

D

C

B

A

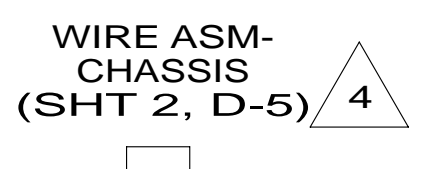

- 1-BBM 16 Y
- 2-BBN 16 Y

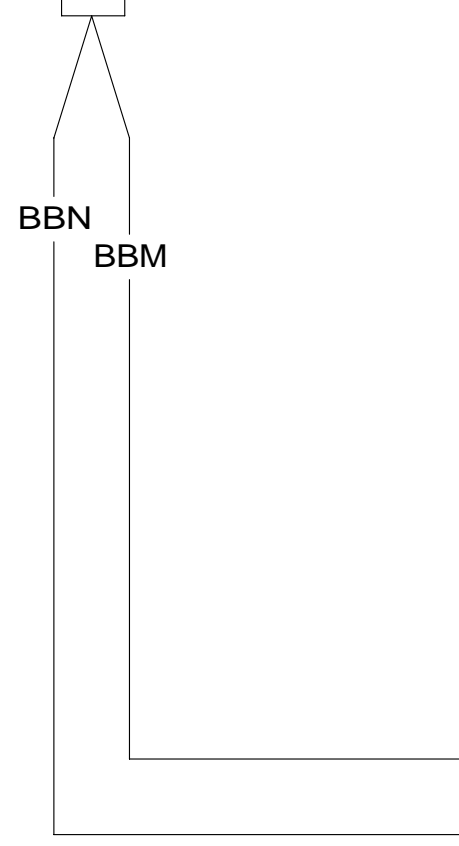

- 1-BBM 16 Y
- 2-DT 16 Y
- 3-BBN 16 Y
- 4-
- 5-
- 6-
- 7-
- 8-

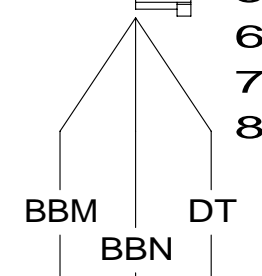

- DT 16 Y
- ER 16 Y



- 1-ER 16 Y
- 2-ES 16 Y
- 3-
- 4-
- 5-
- 6-
- 7-
- 8-

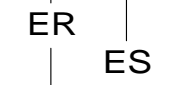

- 1-DR 16 Y
- 2-DT 16 Y
- 3-DU 16 Y
- 4-
- 5-
- 6-
- 7-
- 8-

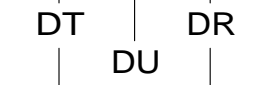

- PJ 14 Y
- NC 14 W

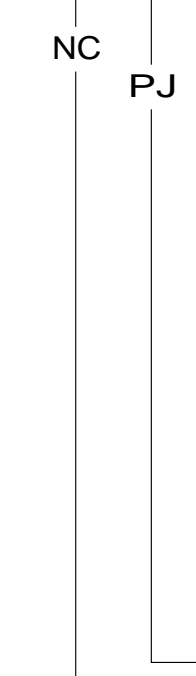

- JC 14 Y
- PJ 14 Y

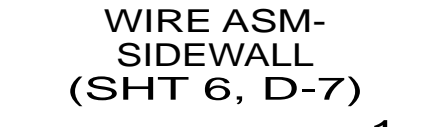
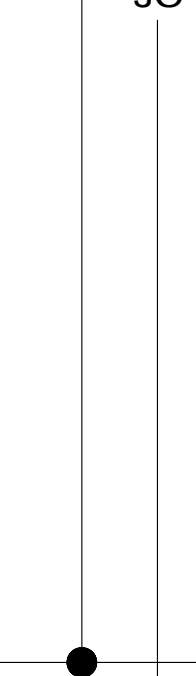

- 1-JC 14 Y
- 2-NC 14 W
- 3-RRA 14 Y
- 4-WL 14 Y
- 5-WM 14 W
- 6-PJ 14 Y

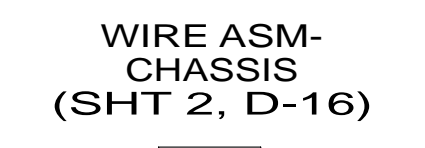
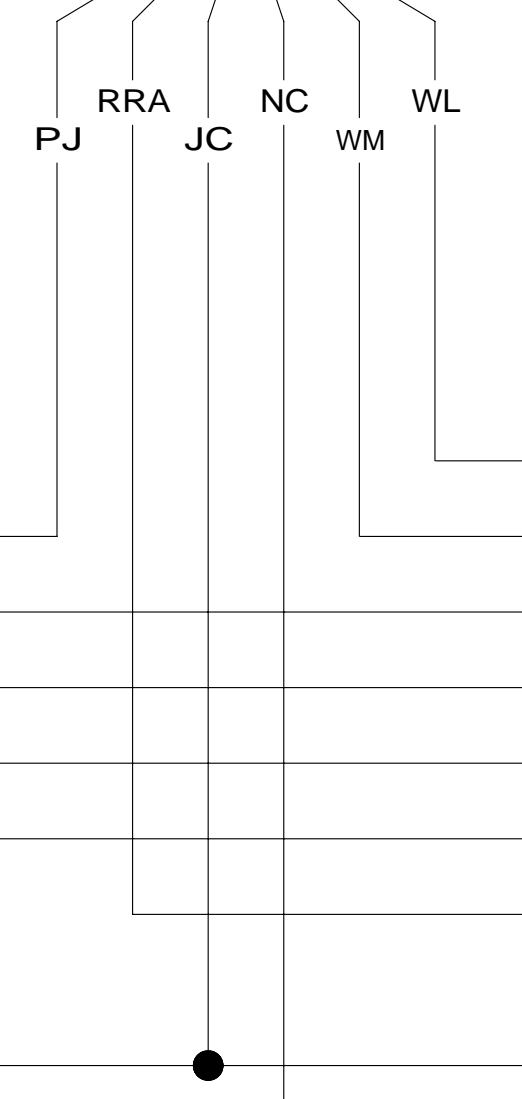

- 1-DR 16 Y
- 2-DU 16 Y
- 3-KKD 16 Y
- 4-JT 16 Y
- 5-WL 14 Y
- 6-WM 14 W
- 7-LJ 16 Y
- 8-LH 16 Y
- 9-LG 16 Y
- 10-YYA 18 W
- 11-KE 14 Y
- 12-ER 16 Y
- 13-ES 16 Y
- 14-JF 14 Y
- 15-UK 16 W

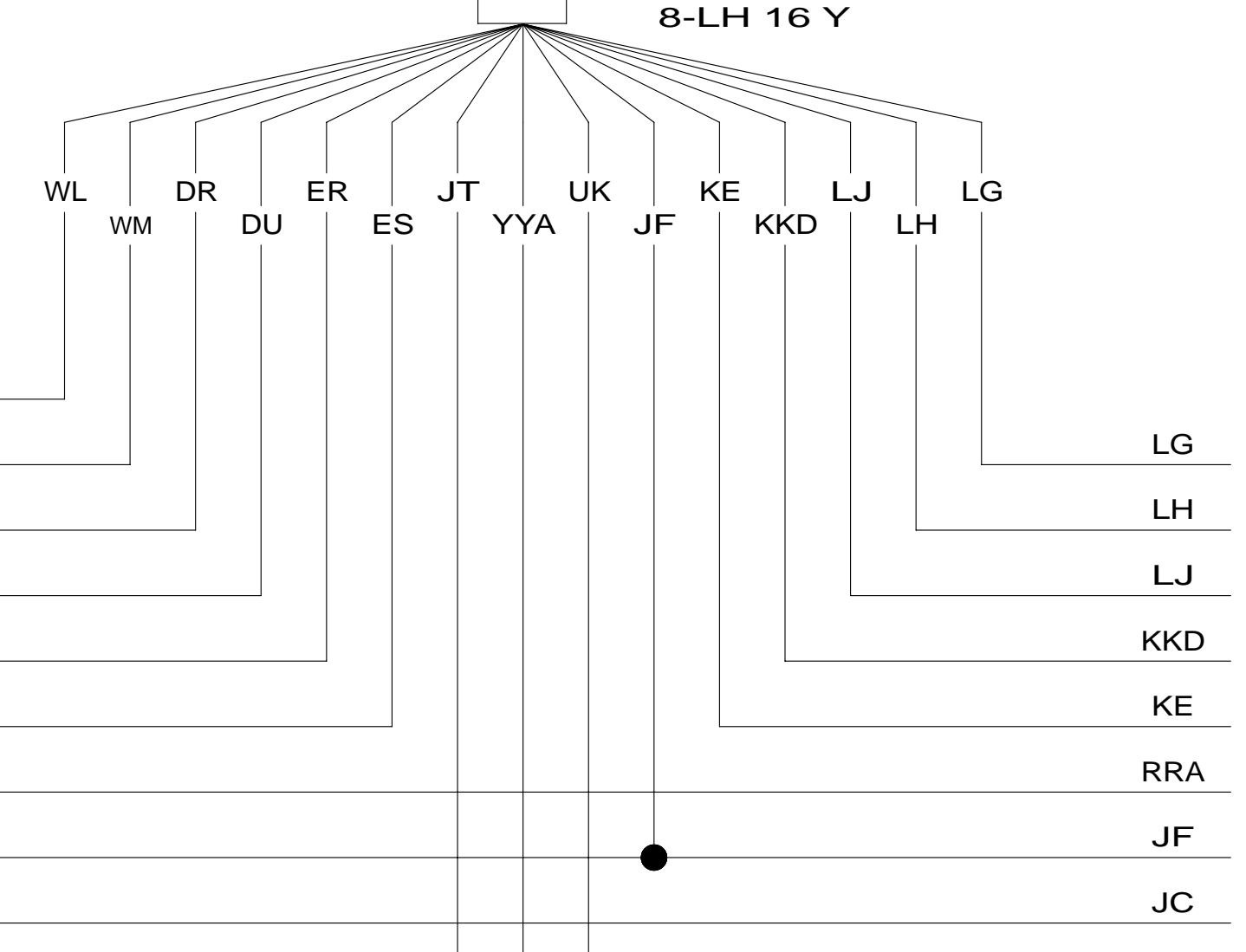

2

2

2

2

GND

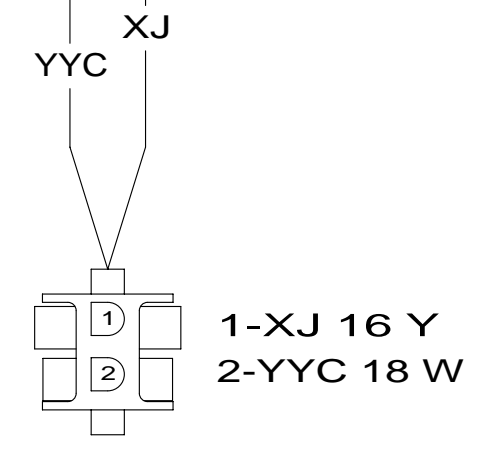

- 1-XJ 16 Y
- 2-YYC 18 W

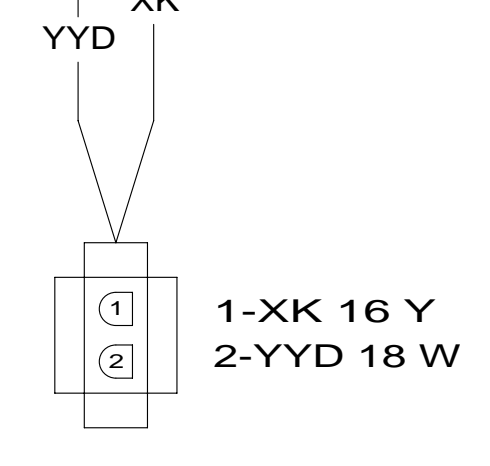

- 1-XK 16 Y
- 2-YYD 18 W

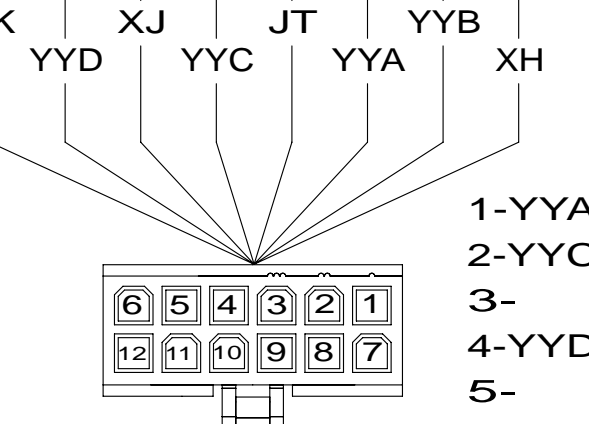

- 1-YYA 18 W
- 2-YYC 18 W
- 3-
- 4-YYD 18 W
- 5-
- 6-YYB 18 W
- 7-JT 16 Y
- 8-XJ 16 Y
- 9-
- 10-XK 16 Y
- 11-
- 12-XH 16 Y

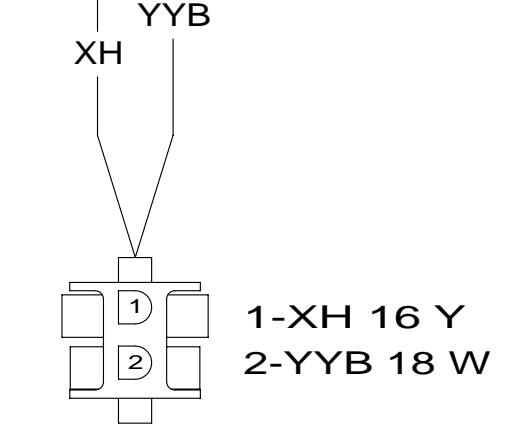
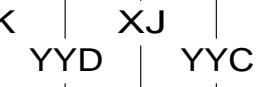

- 1-XH 16 Y
- 2-YYB 18 W

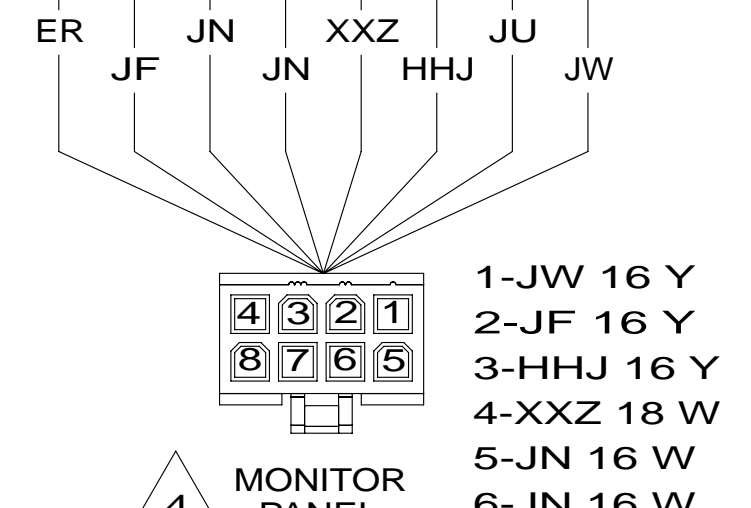
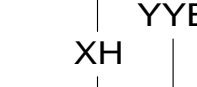

- 1-JW 16 Y
- 2-JF 16 Y
- 3-HHJ 16 Y
- 4-XXZ 18 W
- 5-JN 16 W
- 6-JN 16 W
- 7-JU 16 Y
- 8-ER 16 Y

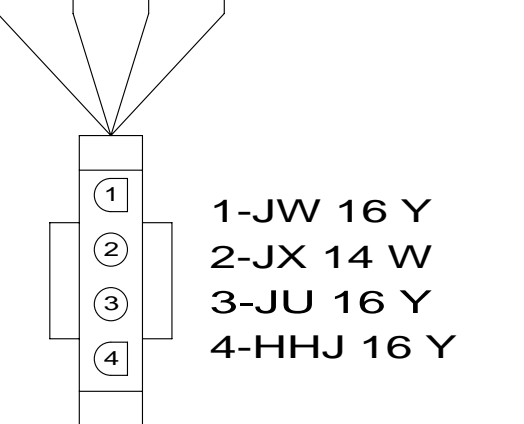

- 1-JW 16 Y
- 2-JX 14 W
- 3-JU 16 Y
- 4-HHJ 16 Y



- 4 SEE MANUFACTURERS DIAGRAM FOR ADDITIONAL INFORMATION.
- 3 GROUNDS ARE SHOWN AS A SINGLE LINE FOR EASE IN TRACING. EACH GROUND CIRCUIT IS SEPERATE IN THE HARNESS.
- 2 NOT A SPLICE POINT. INDICATES ENTRY INTO WIRING HARNESS.

1. SPLICES ARE THEORETICAL AND MAY DIFFER IN THE HARNESS.

NOTES:

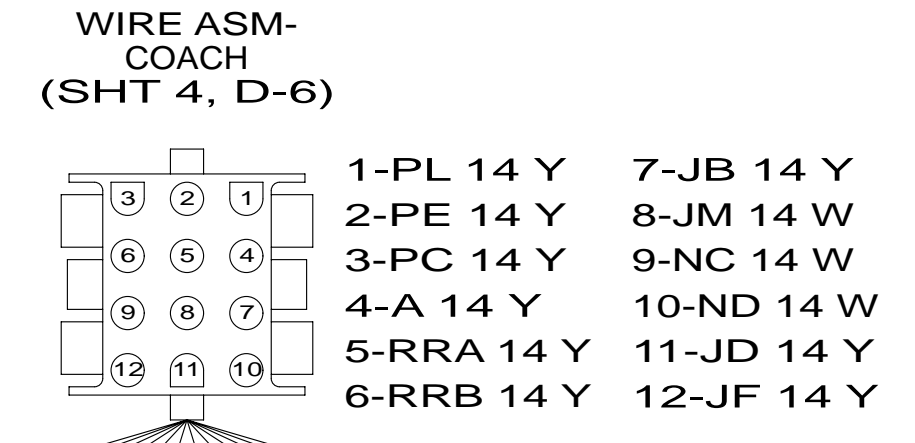
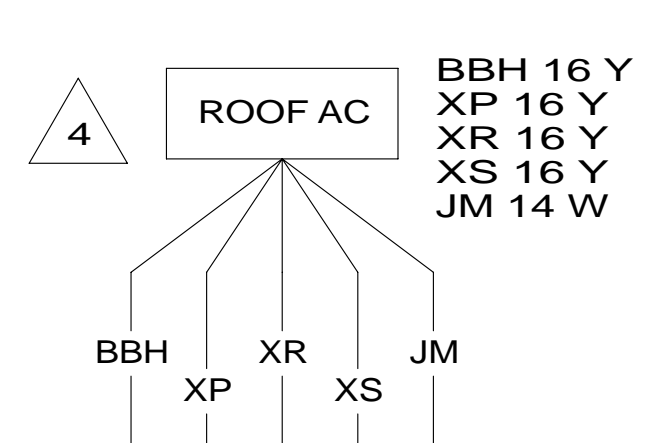
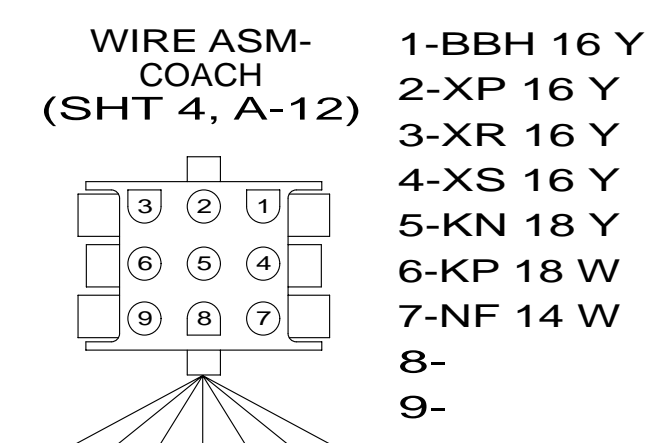
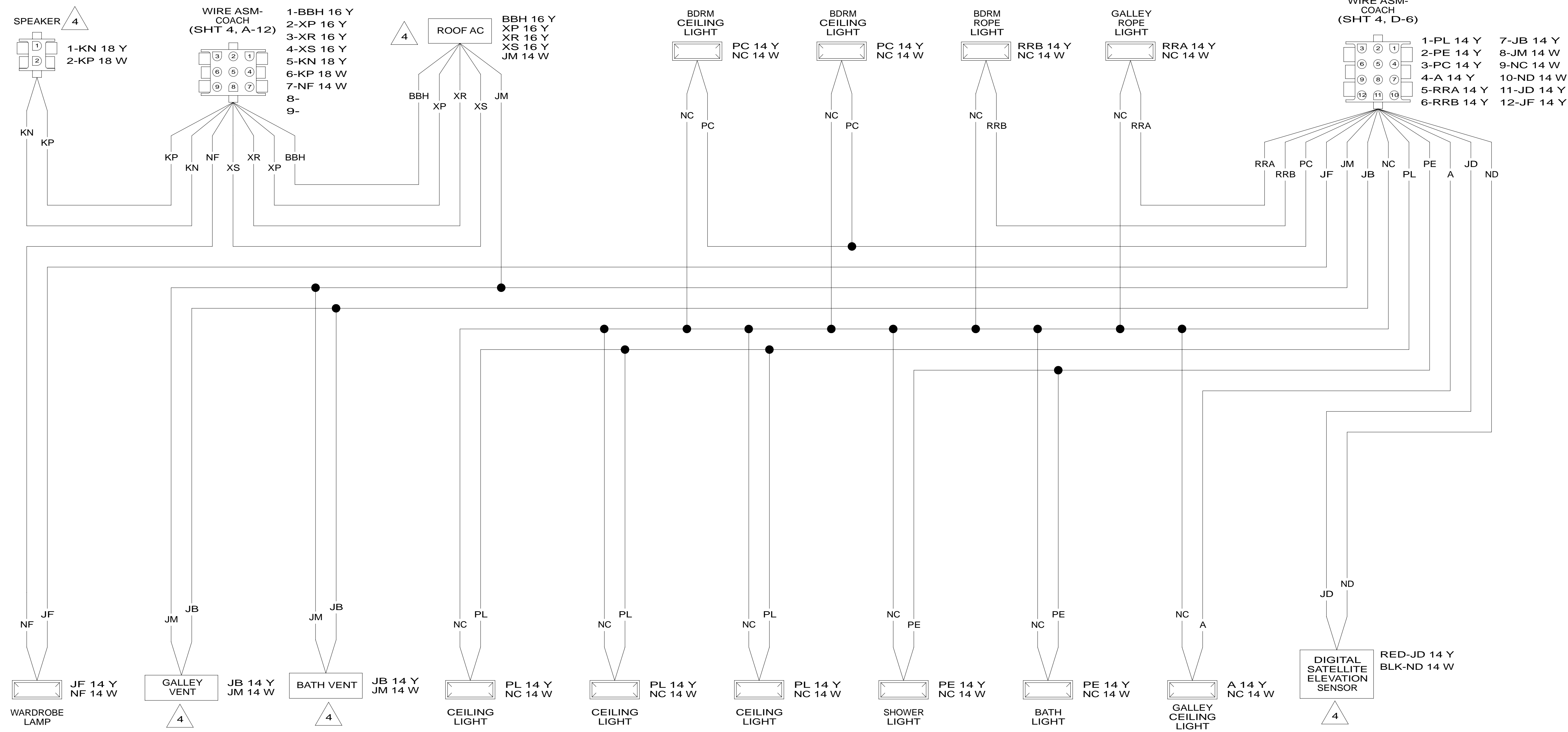

- 4 SEE MANUFACTURERS DIAGRAM FOR ADDITIONAL INFORMATION.
- 3 GROUNDS ARE SHOWN AS A SINGLE LINE FOR EASE IN TRACING. EACH GROUND CIRCUIT IS SEPERATE IN THE HARNESS.
- 2 NOT A SPLICE POINT. INDICATES ENTRY INTO WIRING HARNESS.
1. SPLICES ARE THEORETICAL AND MAY DIFFER IN THE HARNESS.

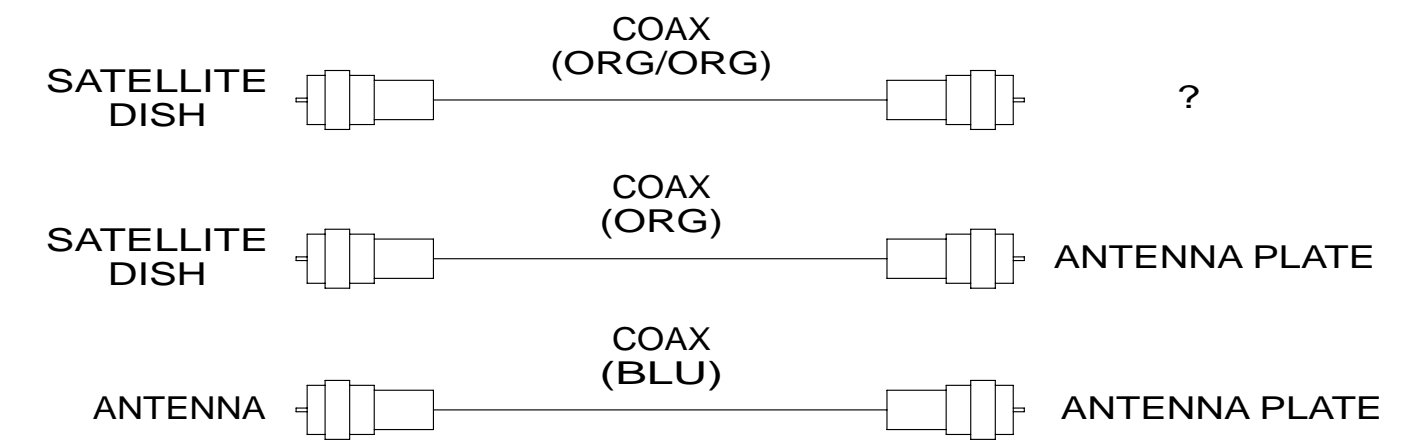

WIRING DIAGRAM-ROOF (WIRE ASM 182536 REV-A)

FIRST USED	<b>13 H25Q</b>	
DO NOT SCALE DRAWING		
TITLE: <b>WIRING DIAGRAM-BODY,12V</b>		
SHEET 5	PART NO <b>180027</b>	REV

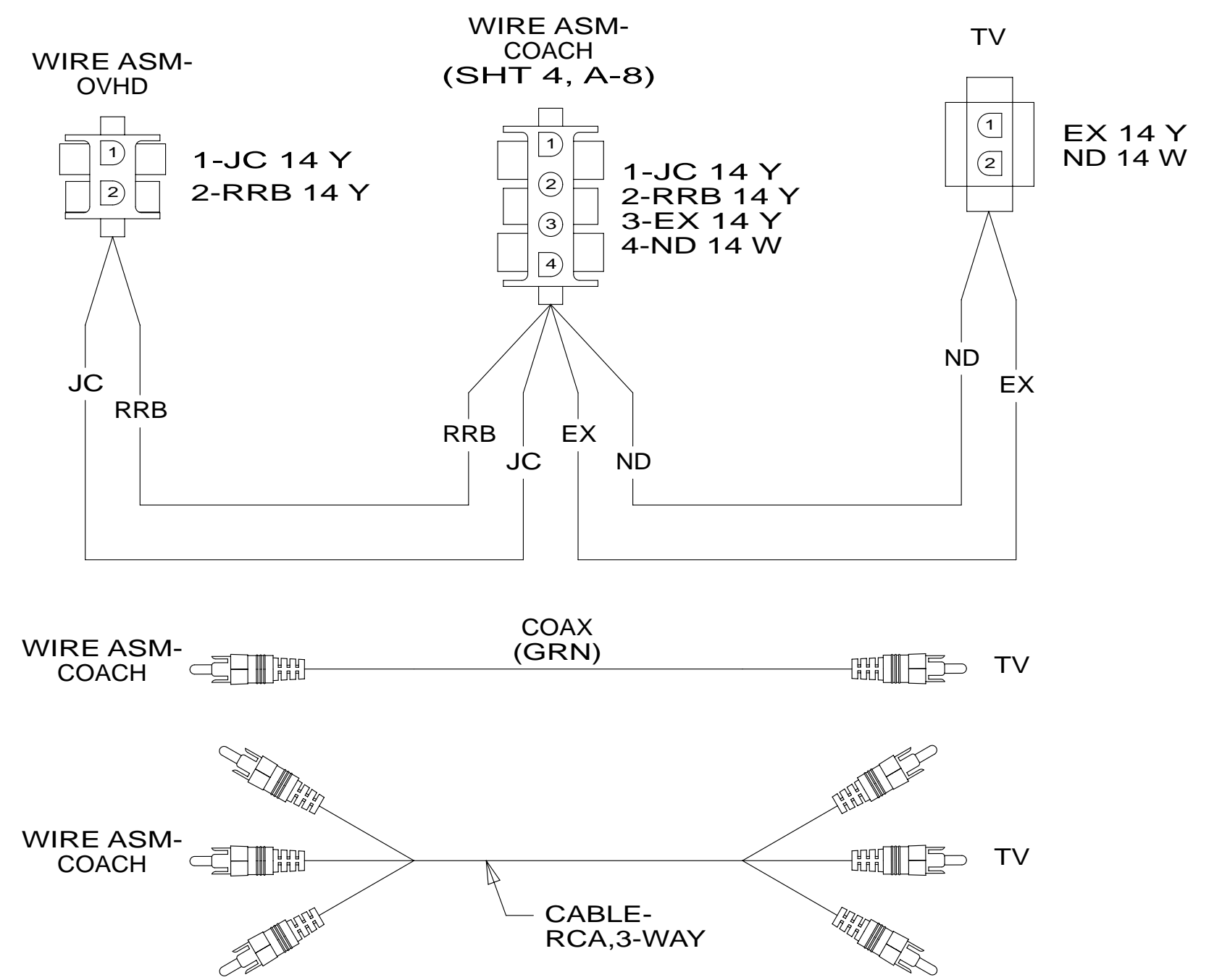

WIRING DIAGRAM-SIDEWALL  
(WIRE ASM 182539 REV-A)

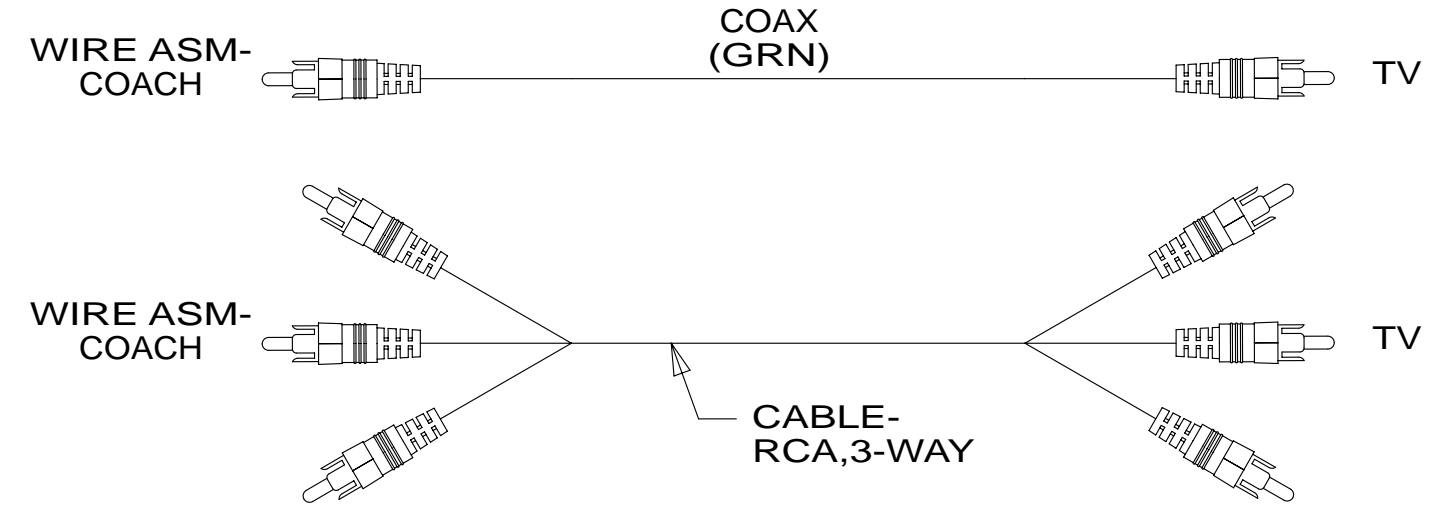

WIRING DIAGRAM-SIDEWALL  
(WIRE ASM 182539 REV-A)

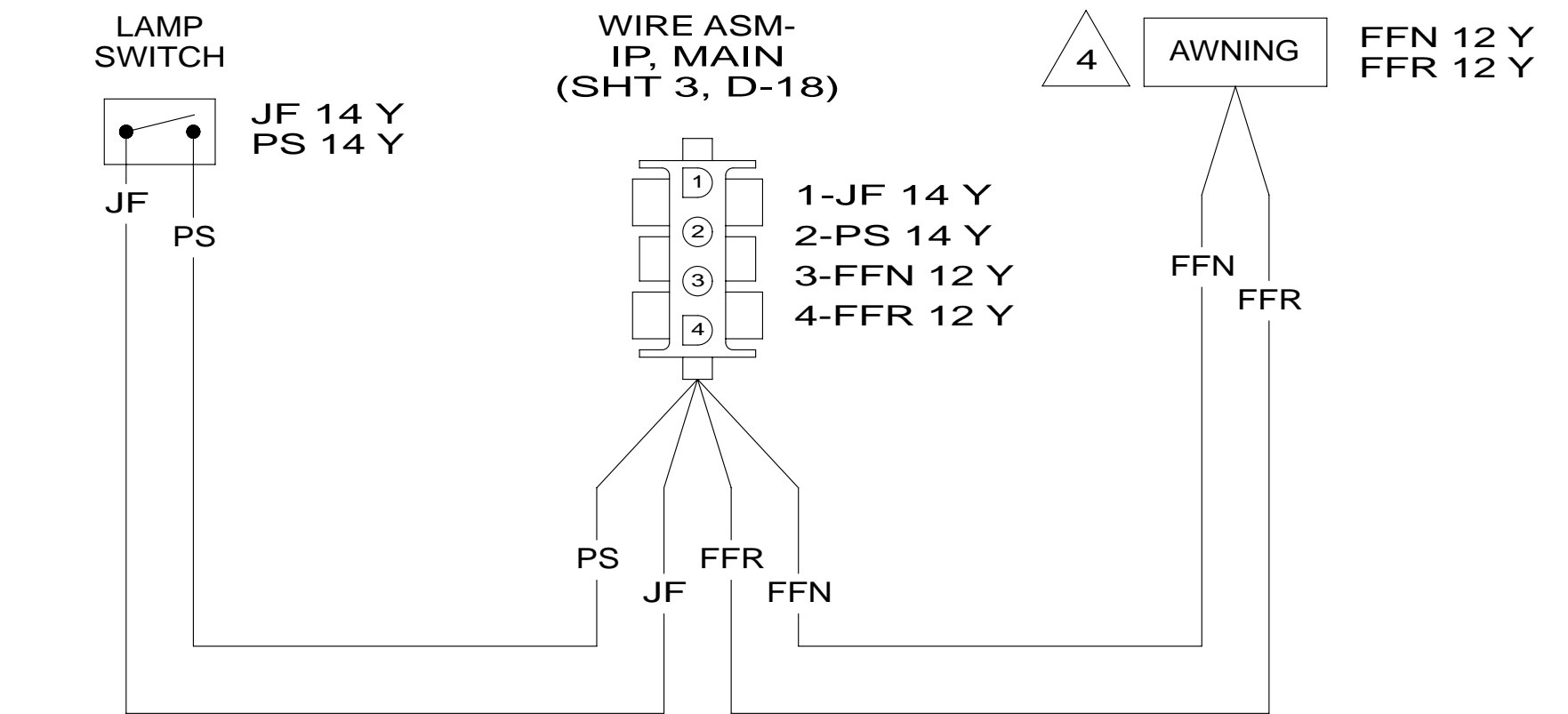

WIRING DIAGRAM-SIDEWALL,FRONT  
(WIRE ASM 182541 REV-A)

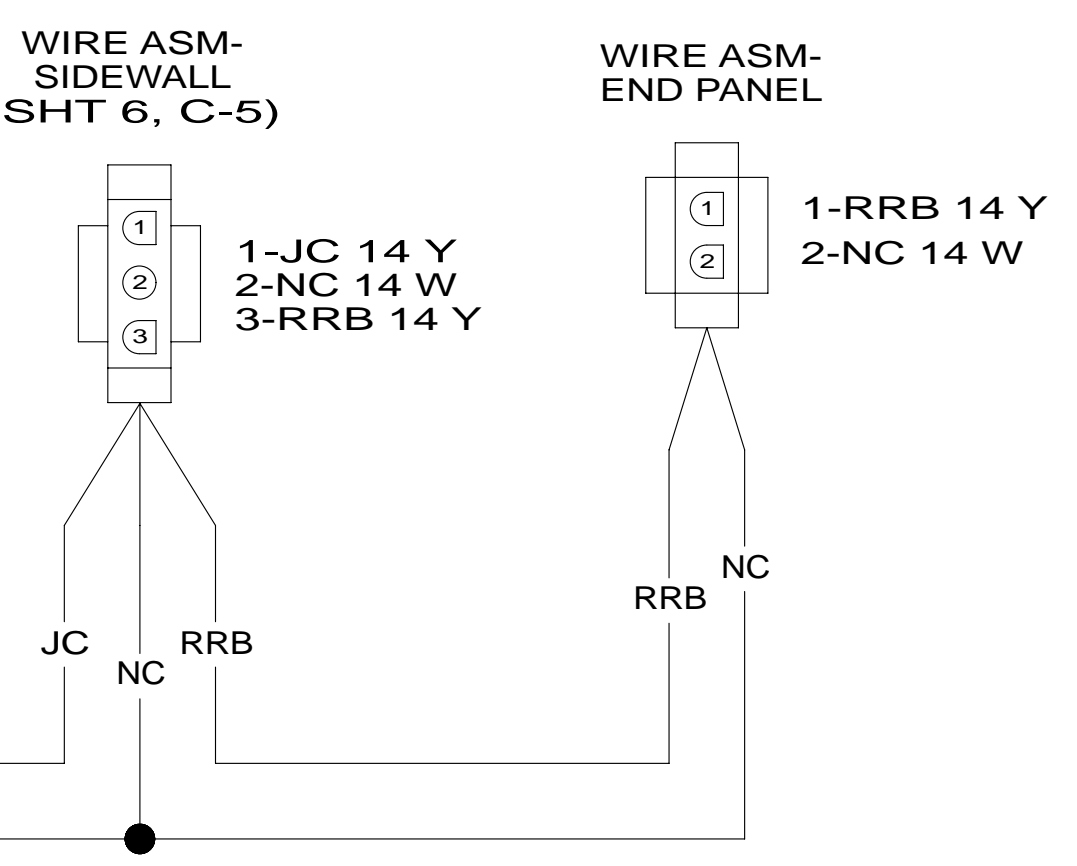

WIRING DIAGRAM-SLIDEOUT  
(WIRE ASM 178888 REV-B)

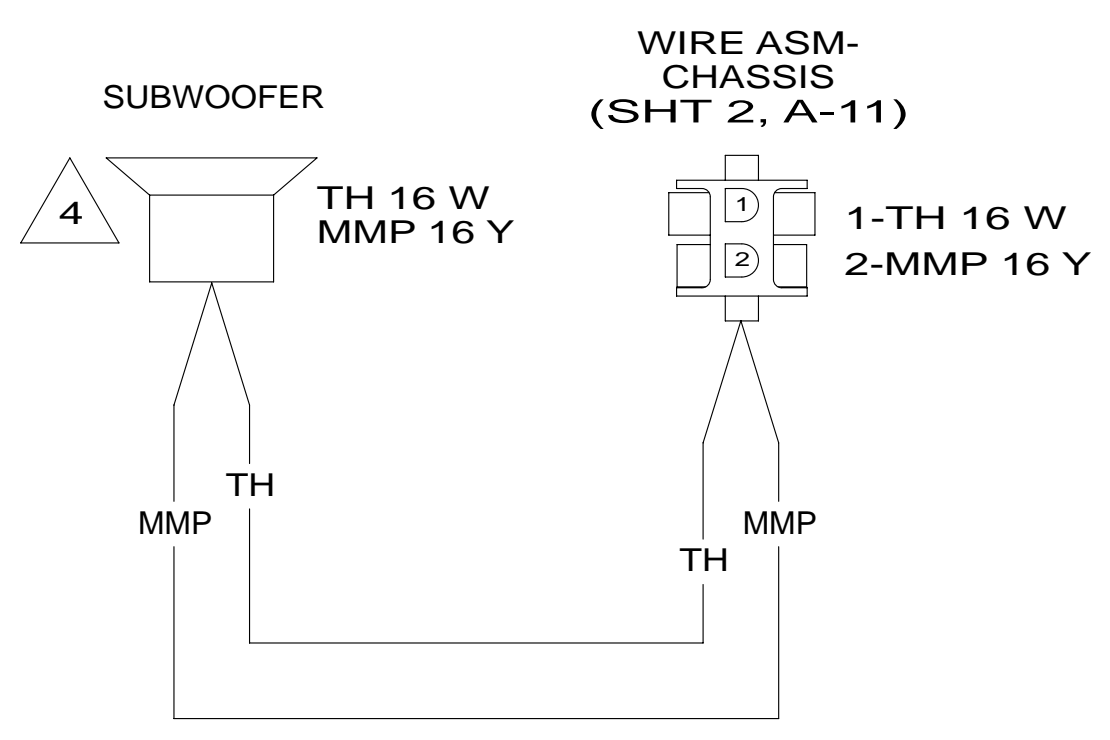

WIRING DIAGRAM-SIDEWALL  
(WIRE ASM 178855 REV-A)

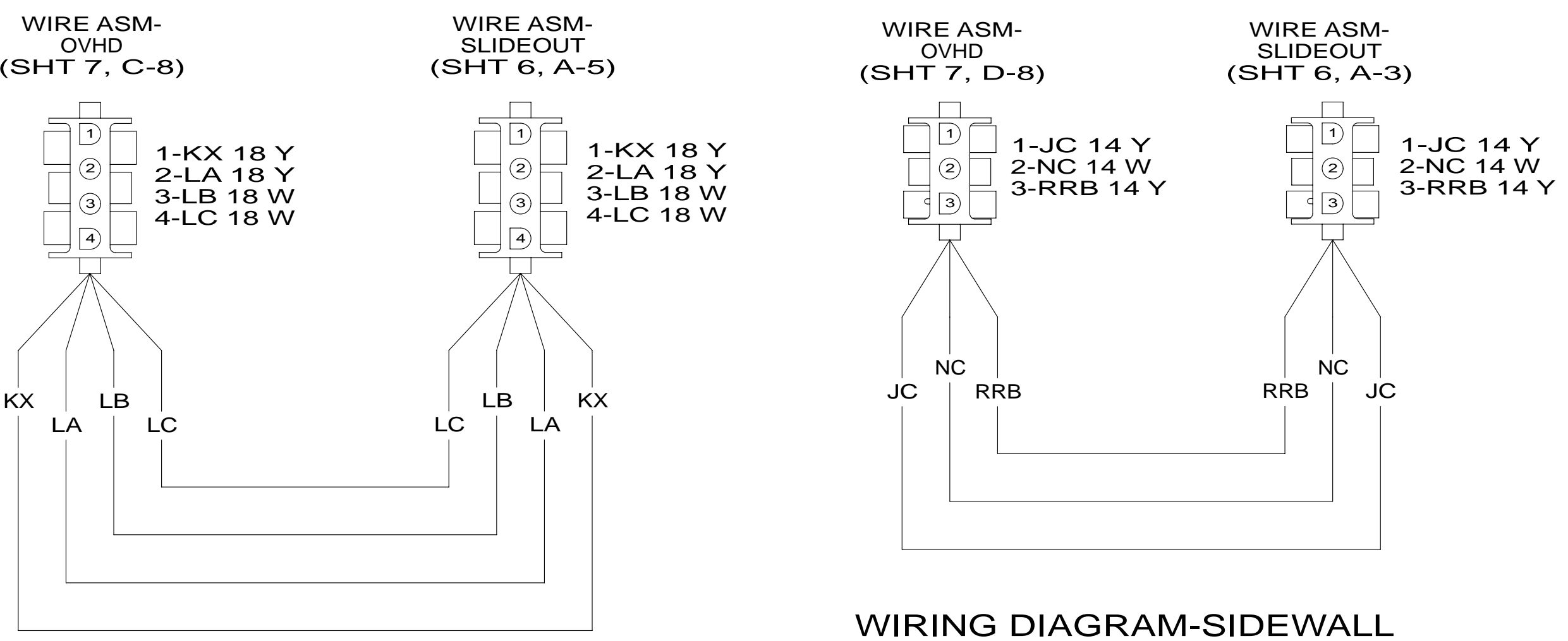

WIRING DIAGRAM-SIDEWALL  
(WIRE ASM 178855 REV-A)

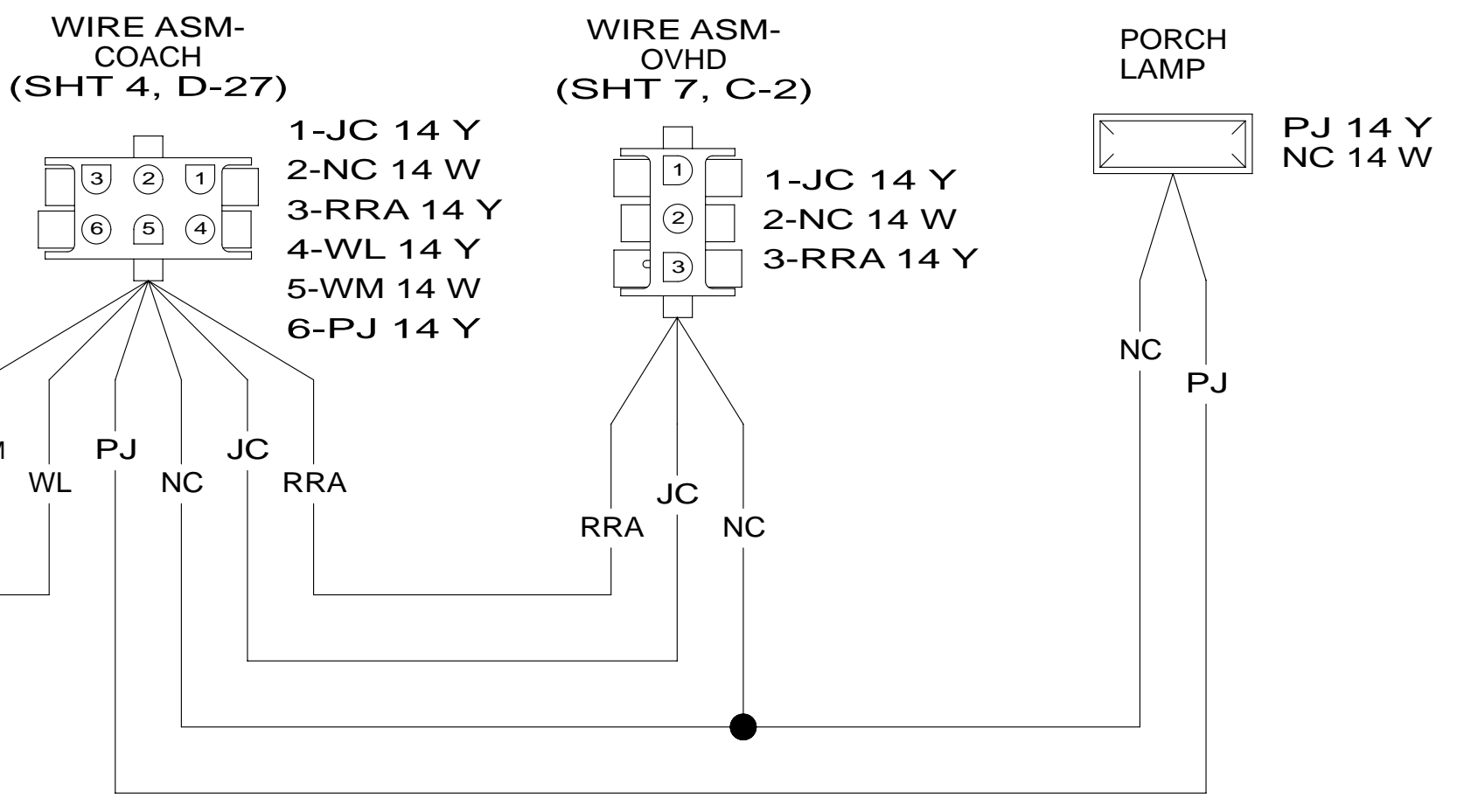

WIRING DIAGRAM-SIDEWALL  
(WIRE ASM 182540 REV-A)

- NOTES:
- 4 SEE MANUFACTURERS DIAGRAM FOR ADDITIONAL INFORMATION.
  - 3 GROUNDS ARE SHOWN AS A SINGLE LINE FOR EASE IN TRACING. EACH GROUND CIRCUIT IS SEPERATE IN THE HARNESS.
  - 2 NOT A SPLICE POINT. INDICATES ENTRY INTO WIRING HARNESS.
  - 1. SPLICES ARE THEORETICAL AND MAY DIFFER IN THE HARNESS.

FIRST USED	13 H25Q	
DO NOT SCALE DRAWING		
TITLE: WIRING DIAGRAM-BODY,12V		
SHEET 6	PART NO 180027	REV

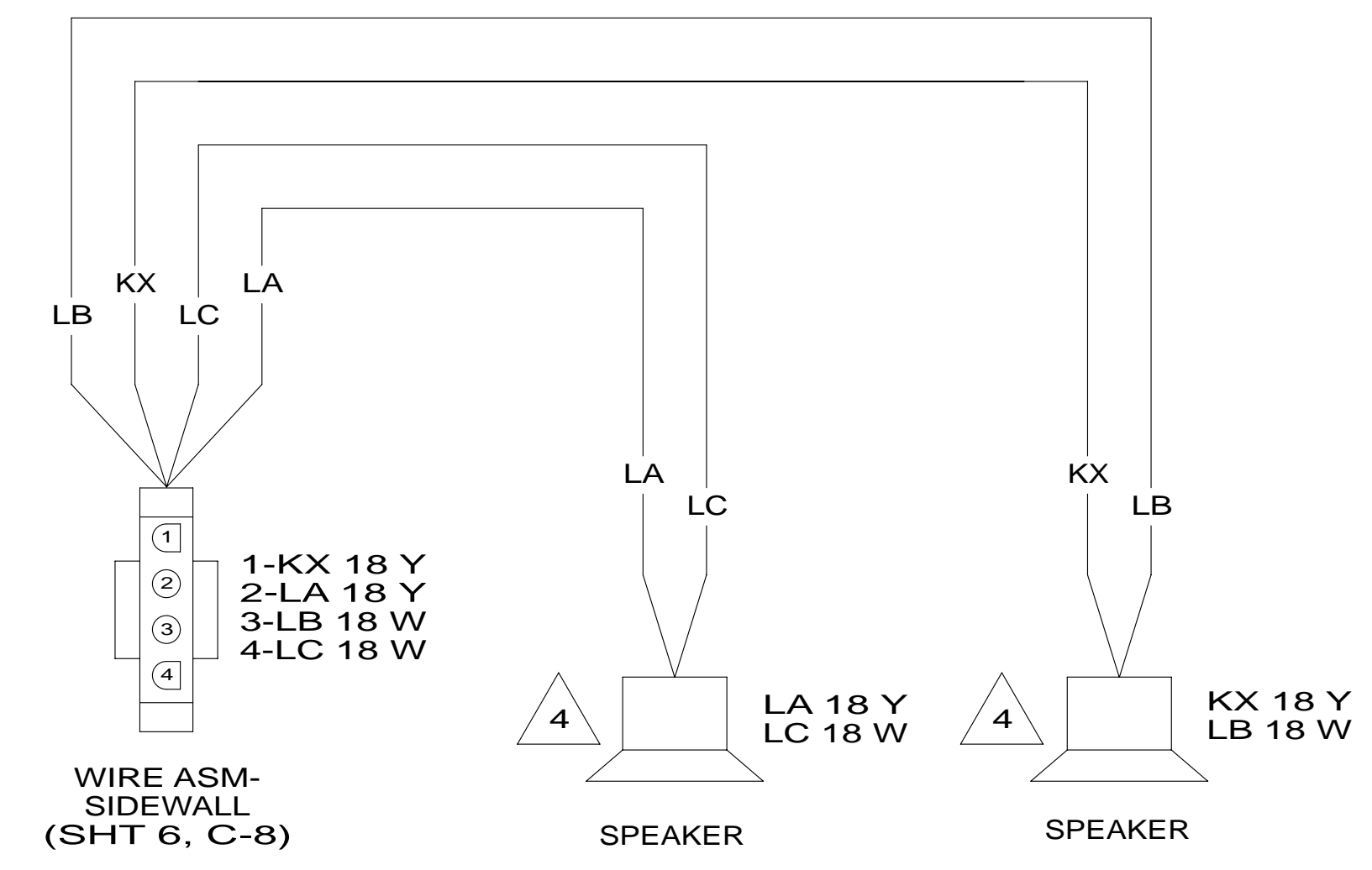
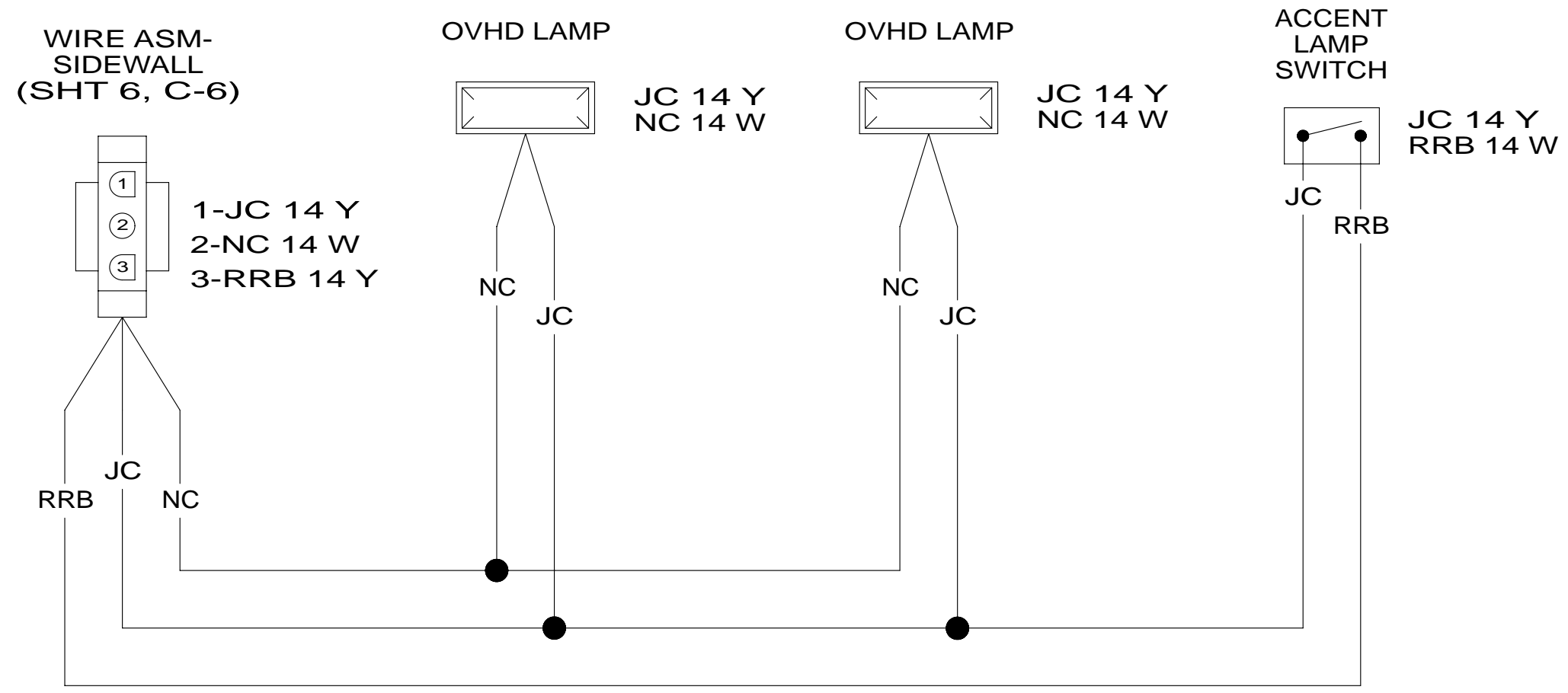

WIRING DIAGRAM-OVHD  
(WIRE ASM 178891 REV-A)

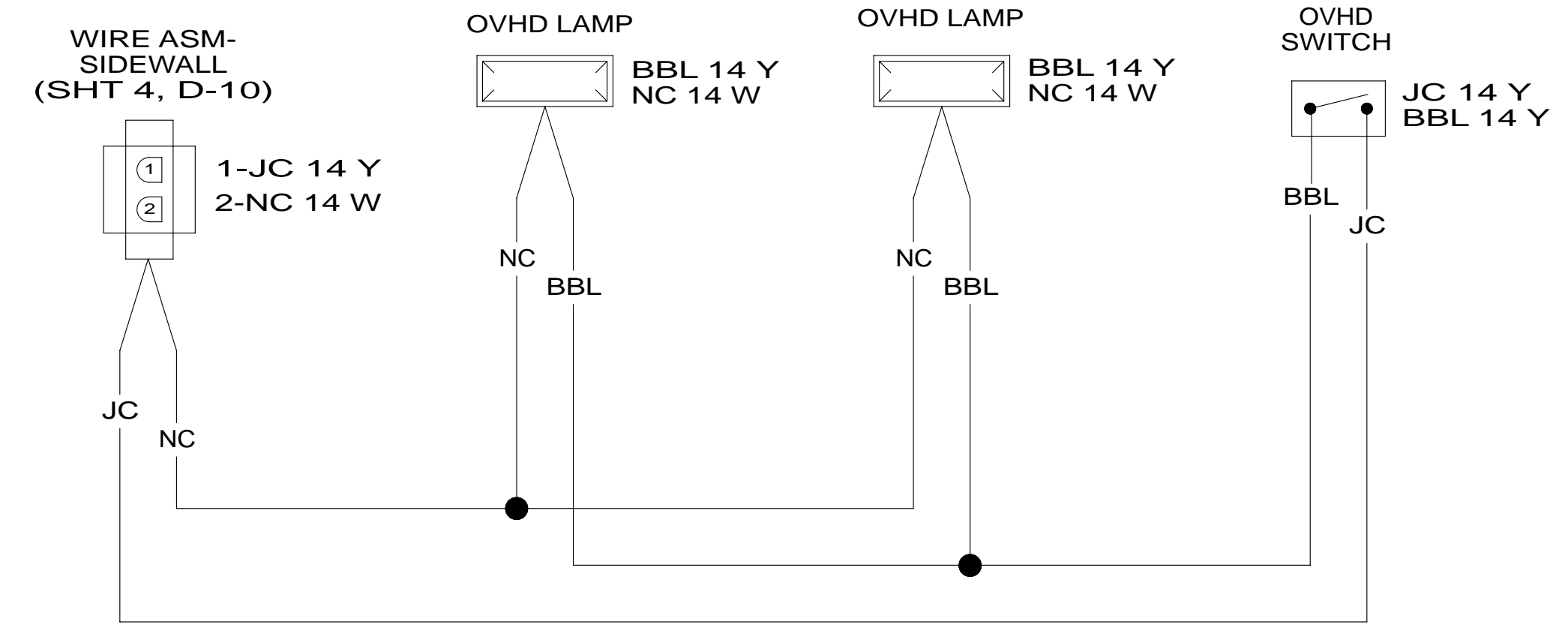

WIRING DIAGRAM-OVHD  
(WIRE ASM 167113 REV-B)

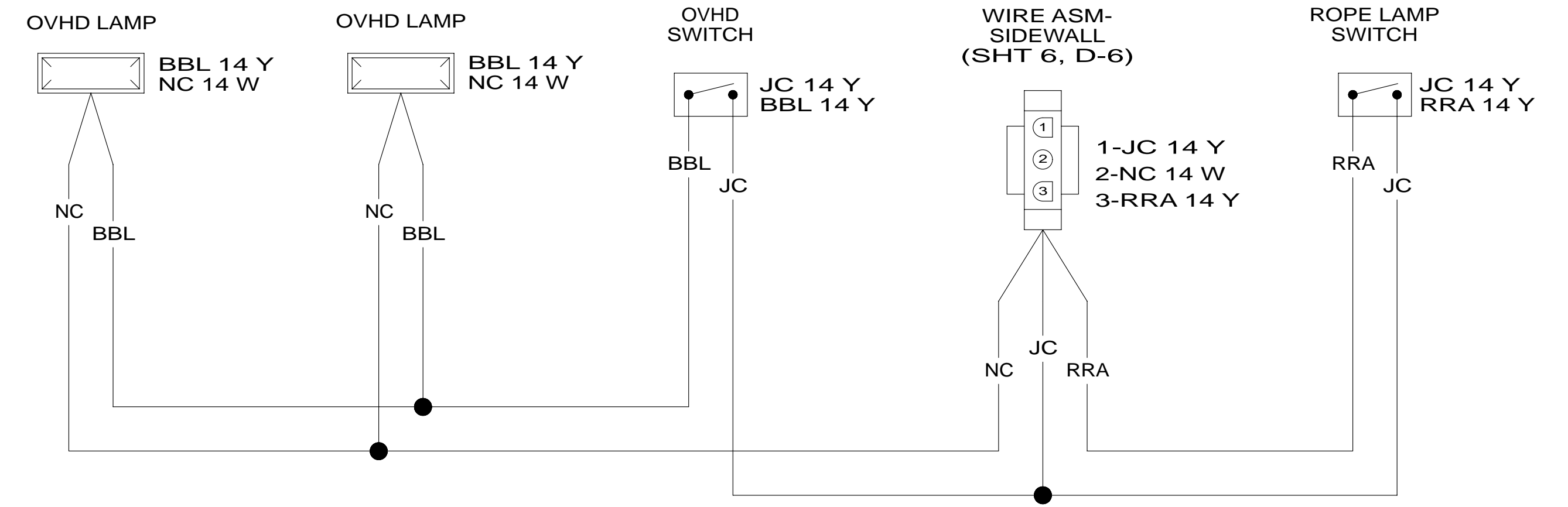

WIRING DIAGRAM-OVHD  
(WIRE ASM 175664 REV-A)

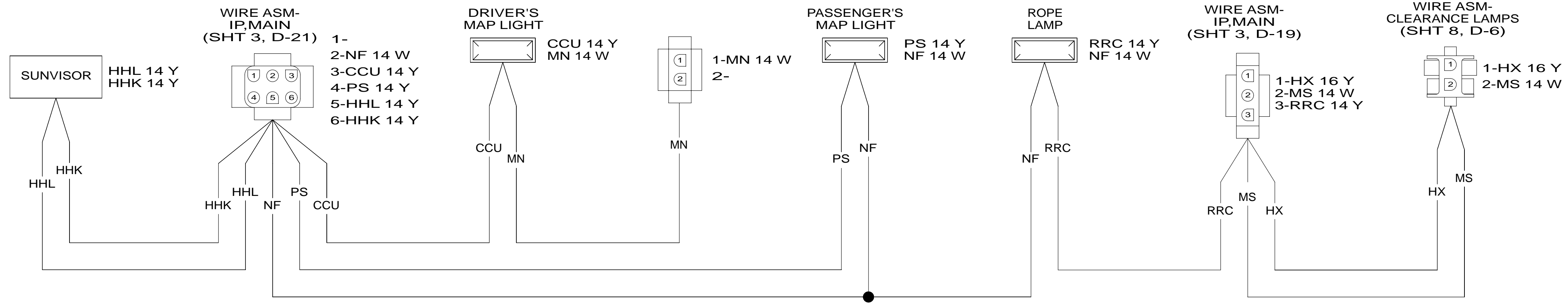

WIRING DIAGRAM-OVHD,FRT  
(WIRE ASM 179785 REV-A)

- 4 SEE MANUFACTURERS DIAGRAM FOR ADDITIONAL INFORMATION.
- 3 GROUNDS ARE SHOWN AS A SINGLE LINE FOR EASE IN TRACING. EACH GROUND CIRCUIT IS SEPERATE IN THE HARNESS.
- 2 NOT A SPLICE POINT. INDICATES ENTRY INTO WIRING HARNESS.
- 1. SPLICES ARE THEORETICAL AND MAY DIFFER IN THE HARNESS.

NOTES:

FIRST USED	13 H25Q	
DO NOT SCALE DRAWING		
TITLE: WIRING DIAGRAM-BODY,12V		
SHEET 7	PART NO 180027	REV

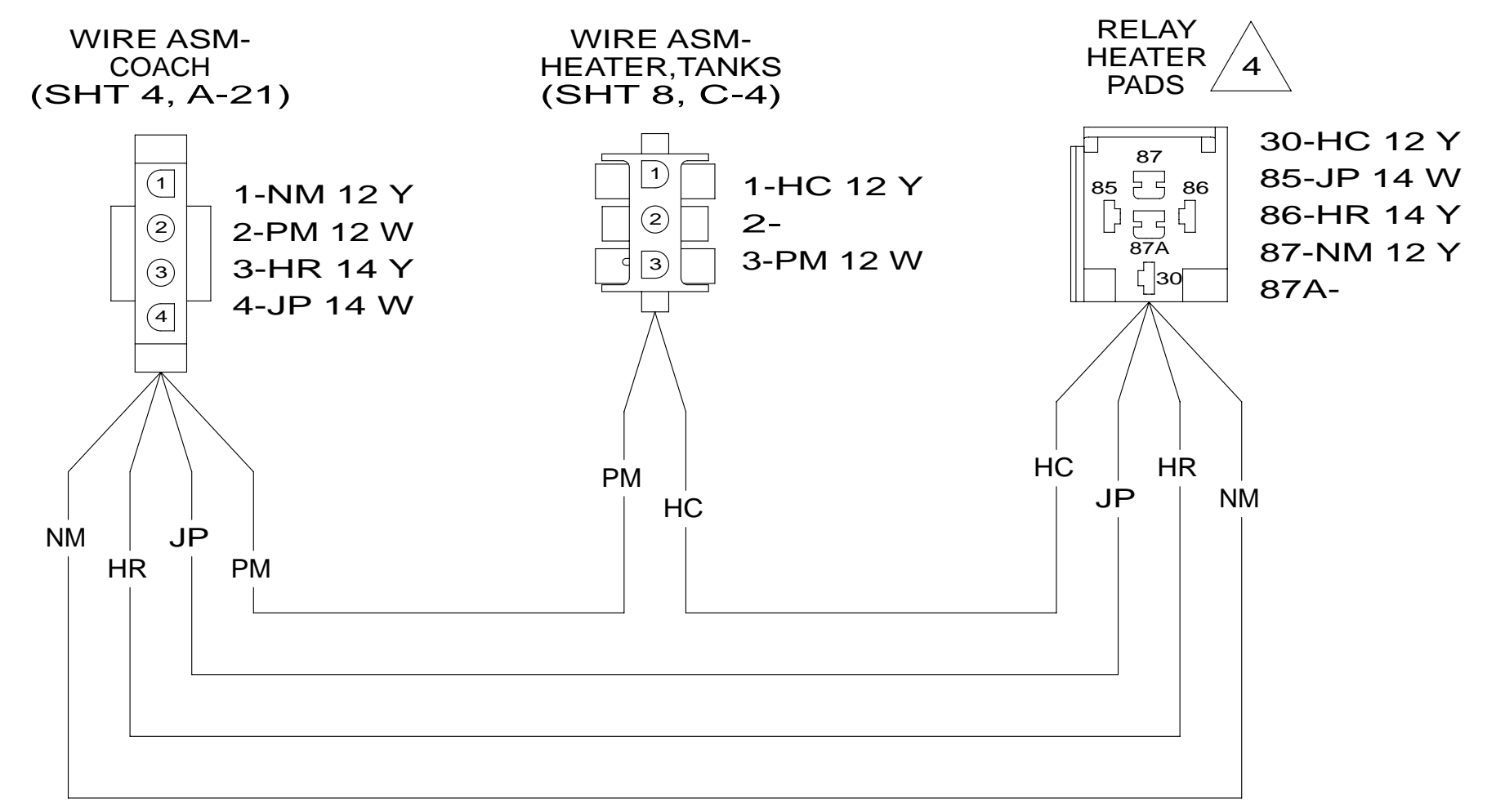
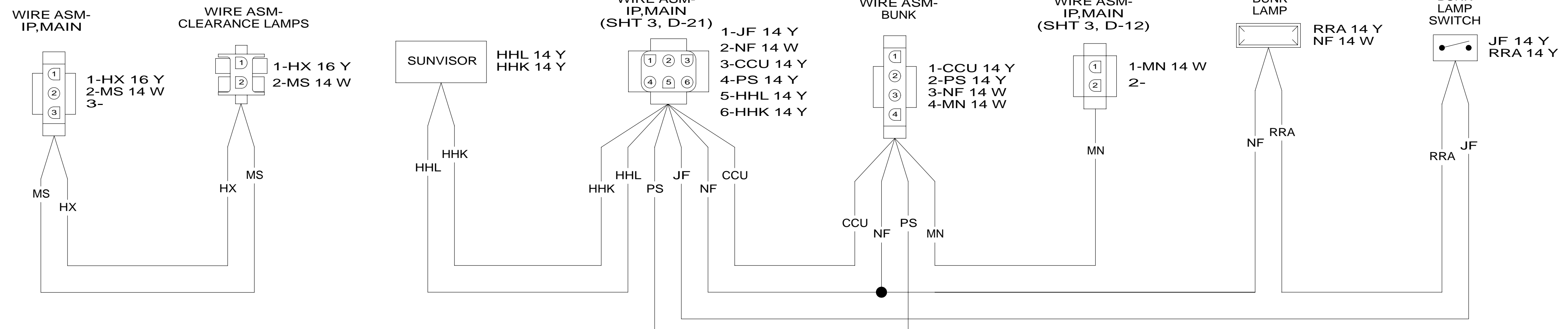

**WIRING DIAGRAM-HEATER,RELAY**  
(WIRE ASM 153891 REV-B)

**WIRING DIAGRAM-HEATER,TANKS**  
(WIRE ASM 134551-11 REV-M)

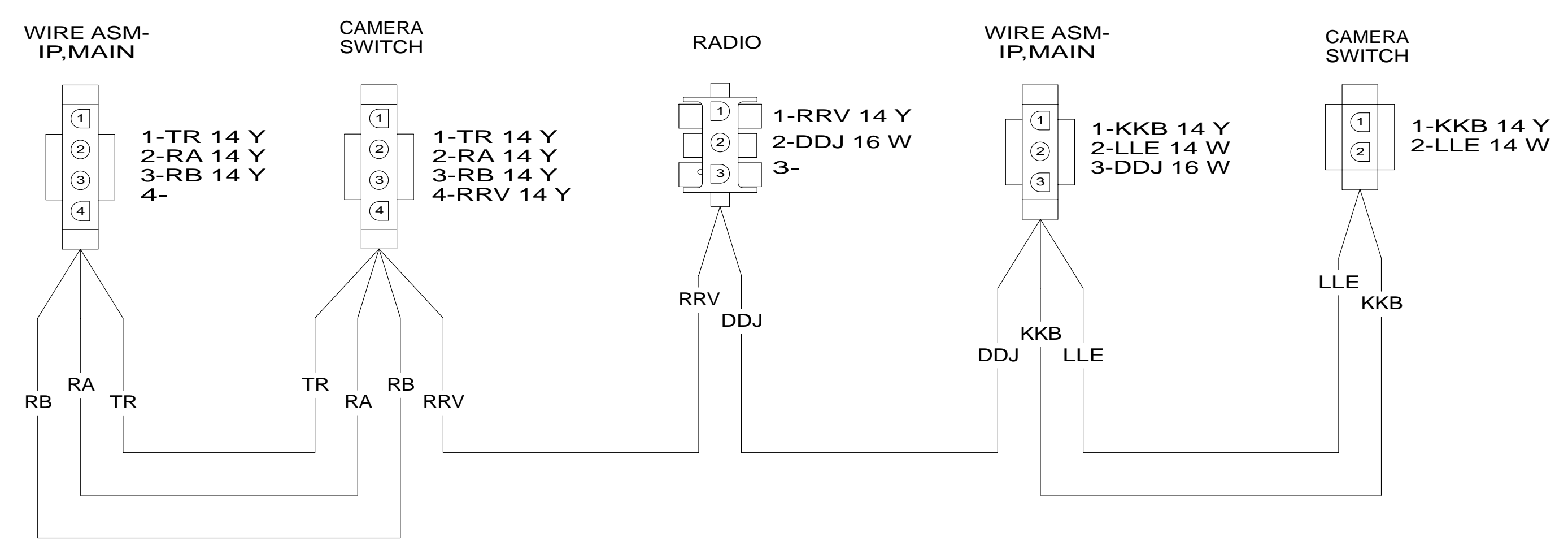

**WIRING DIAGRAM-CAMERA SWITCH**  
(WIRE ASM 176660 REV-C)

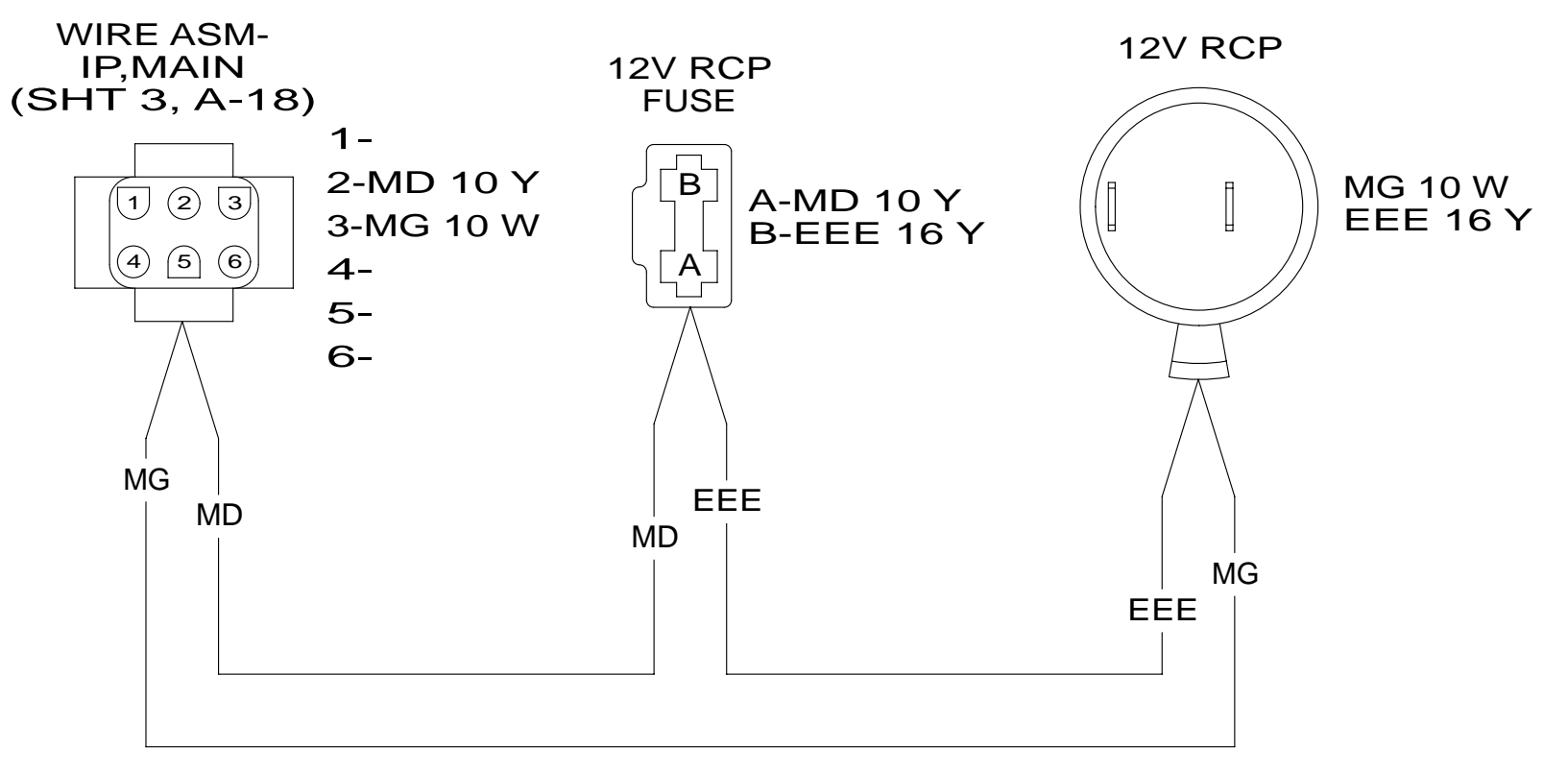

**WIRING DIAGRAM-12V RCP**  
(WIRE ASM 175753 REV-A)

- 4 SEE MANUFACTURERS DIAGRAM FOR ADDITIONAL INFORMATION.
- 3 GROUNDS ARE SHOWN AS A SINGLE LINE FOR EASE IN TRACING. EACH GROUND CIRCUIT IS SEPERATE IN THE HARNESS.
- 2 NOT A SPLICE POINT. INDICATES ENTRY INTO WIRING HARNESS.
1. SPLICES ARE THEORETICAL AND MAY DIFFER IN THE HARNESS.

NOTES:

FIRST USED	<b>13 H25Q</b>	
DO NOT SCALE DRAWING		
TITLE: <b>WIRING DIAGRAM-BODY,12V</b>		
SHEET 8	PART NO <b>180027</b>	REV
		12-Sep-2012