

- NOTES:
1. SLOPE OF HORIZONTAL PIPING TO BE MINIMUM OF 3 PER 305 mm.
 2. SLOPE OF TRAP ARM MUST BE 6 PER 305 mm.
 3. ALL PIPE AND FITTINGS TO BE ASSEMBLED WITH SOLVENT 004020-01-000 (USA), 004020-02-000 (CAN)
 4. USE SMOOTH PLUMBERS PUTTY 167459-01-000 TO SEAL STRAINER (0.2 PER STRAINER).
 5. SEAL AROUND SHOWER WITH SILICONE.
 6. VENT PIPE MUST PROJECT 51 MIN AND 64 MAX ABOVE ROOF FOR PROPER FIT AND FUNCTION. ADD S-1 (116666-01-CHT SEAL-VENT PIPE) AROUND PIPE ON ROOF BEFORE VENT CAP IS INSTALLED.
 7. SECURE VENT PIPE TO TANK WITH CLAMP 062401-02-000.
 8. SECURE DRAINAGE PIPES TO CABINET USING WIRE TIE 108046-02-000, AND SCREW 000G67-10-12U AT INTERVALS OF NOT OF NOT MORE THAN 4 FEET APART.
 9. SEE DRAWING 061607 FOR INSTALLATION OF GROMMETS.
 10. APPLY PRIMER 126427-02-000 AND CEMENT 126427-01-000 BETWEEN ELBOW AND FLEX PIPE.
 11. GLUE FITTING AFTER CABINET IS INSTALLED.

- 21S WASHER & DRYER-PAIR
- 21M WASHER/DRYER PREP
- 54E WASHER/DRYER COMBO
- 1B1 CODES/STANDARDS USA
- 265 CODES/STANDARDS-CSA/CMVSS

		COPYRIGHT 2013 WINNEBAGO INDUSTRIES, INC.	
DTR	ORIG. DATE	ALL DIMENSIONS ARE IN MILLIMETERS	
CHKR			
P.E.			
M.E.	FIRST USED		
DSNR		13 J35P	
UNSPECIFIED TOLERANCES ARE: WHOLE DIM (X) : 3 ONE-PLACE (X.X) : 1.5 TWO-PLACE (X.XX) : 0.50 ANGLE : 1°		MATERIAL:	
THIRD ANGLE PROJECTION			
DO NOT SCALE DRAWING		REFER TO ES0018 FOR FASTENER TIGHTENING GUIDELINES	
TITLE: DRAINAGE SYSTEM INSTL			
SHEET 1 OF 4		PART NO	181008
REF:		1	23-Apr-2013

FOR
DRAINAGE
CALLOUTS
SEE DWG NO
116229-01-000

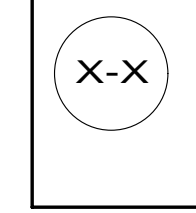

TOILET
160815-01-CHT
SCREW
087721-01-000 (8)

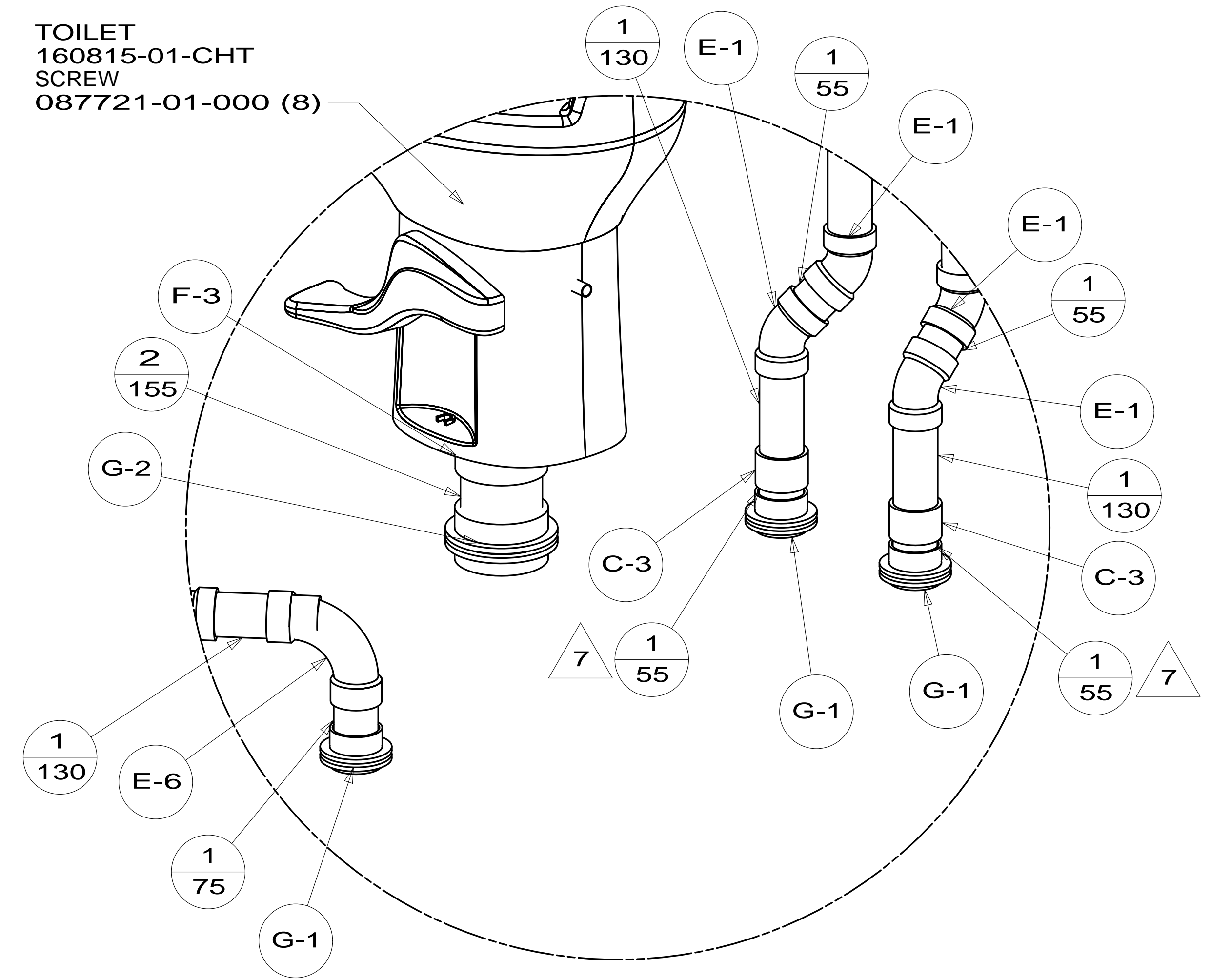

DETAIL B
(SHOWN W/OUT FLOOR & CABINETS)

SHOWER INSTL
166788-13-000
STRAINER
066440-01-000
WASHER-RUBBER
127440-02-CHT
TAILPIECE
011069-02-000
NUT
130403-02-000

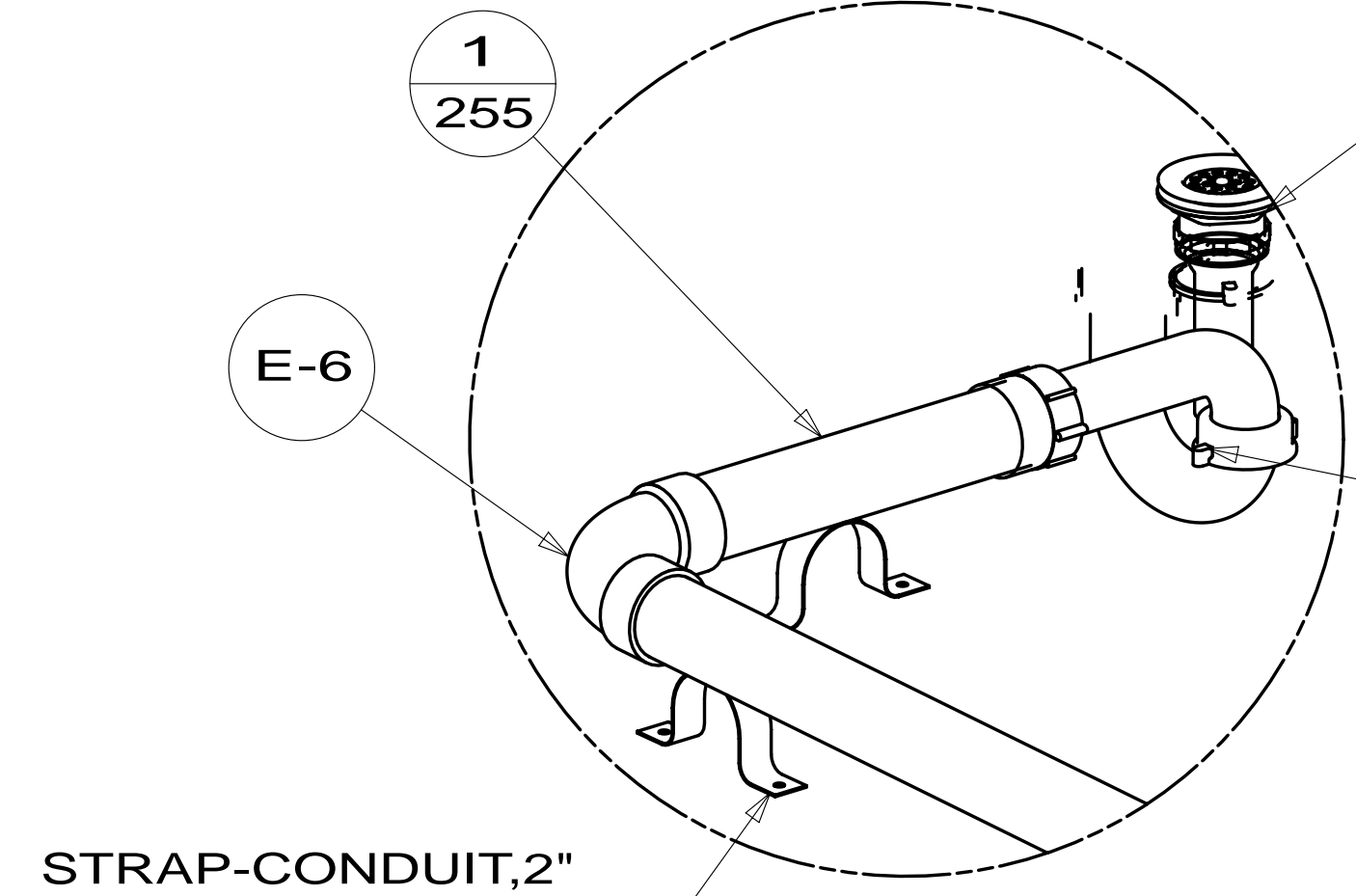

DETAIL C
(SHOWN W/OUT FLOOR & CABINETS)

STRAP-CONDUIT, 2"
008406-01-000 (2)

WASTE ASM-LAV, POPUP, VESSEL
176640-03-CHT

- 1B1 P-1
- 265 P-3
- 1B1 A-15

DETAIL C

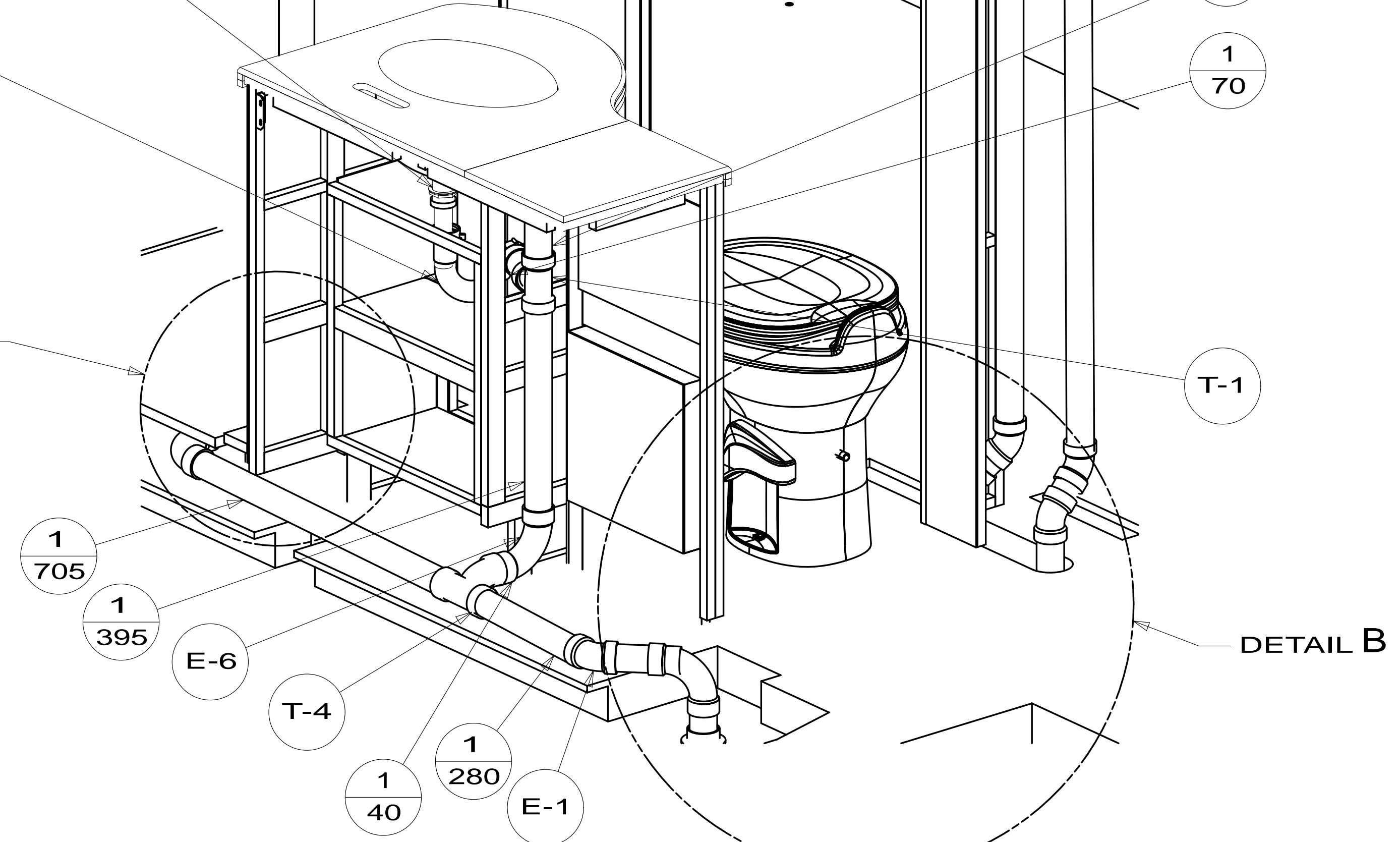

VIEW A

DETAIL B

FIRST USED	13 J35P	
TITLE:	DO NOT SCALE DRAWING	
	DRAINAGE SYSTEM INSTL	
SHEET 2	PART NO 181008	REV
		23-Apr-2013

- SINK
184806-01-CHT
- STRAINER
092303-01-000 (2)
- BRACKET
140002-01-CHT (8)
- SCREW
142261-02-CHT (8)
- SEAL (2365)

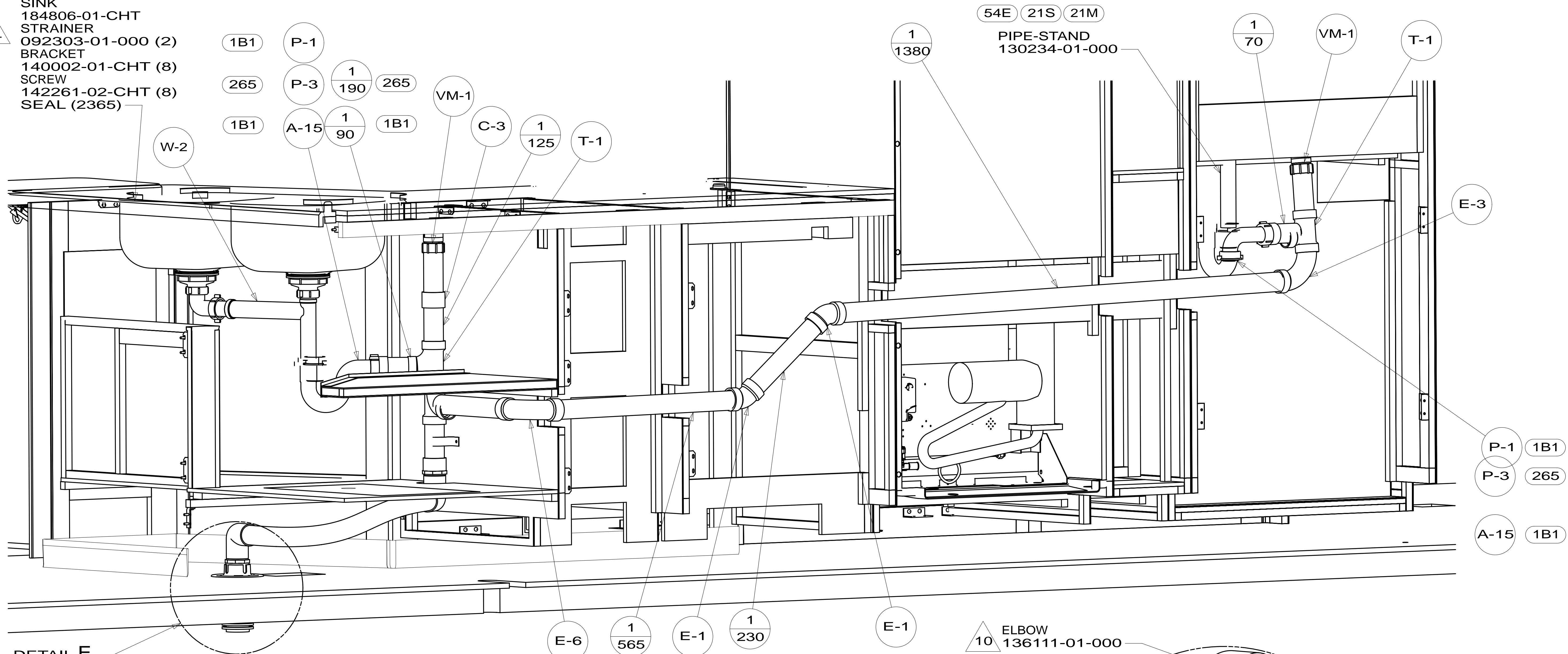

VIEW D

DETAIL E

FITTING-BULKHEAD, DRAINAGE
136656-01-CHT

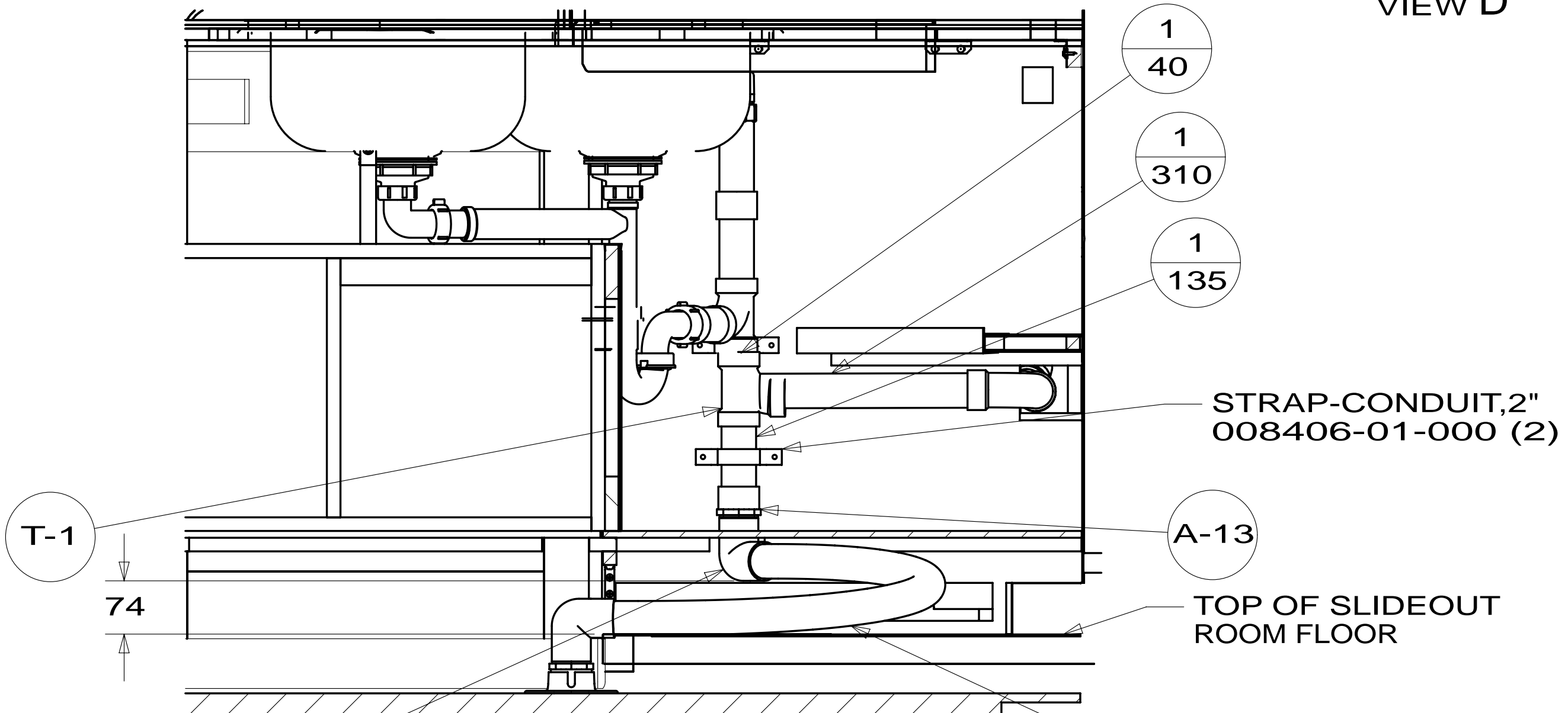

SECTION F-F
(ROTATED)

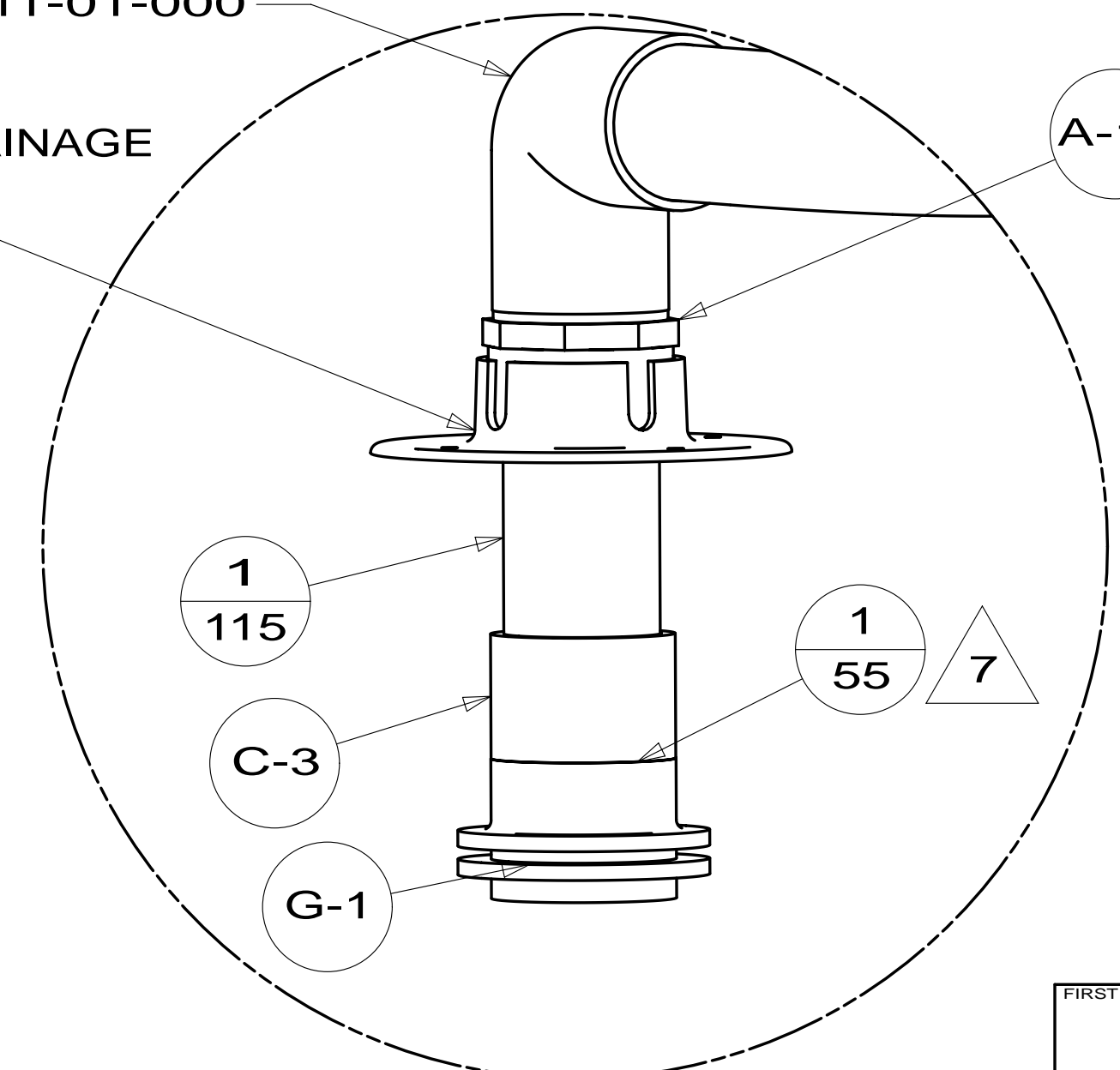

DETAIL E
(SHOWN W/OUT FLOOR & CABINETS)

FIRST USED	13 J35P
DO NOT SCALE DRAWING	
TITLE: DRAINAGE SYSTEM INSTL	
SHEET 3	PART NO 181008 REV

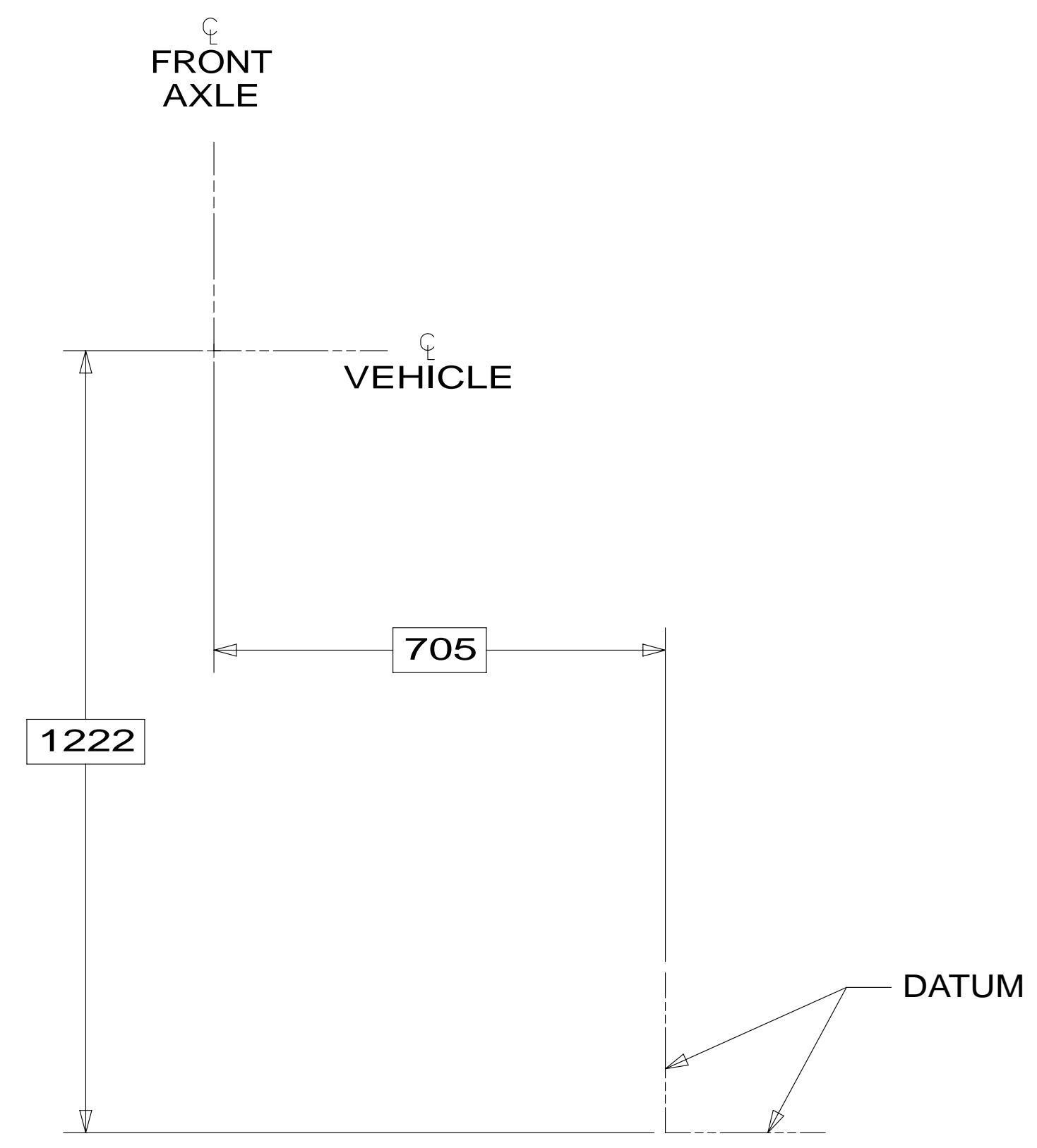

**TOP VIEW
(SHOWING ONLY TANKS & DRAINS)**

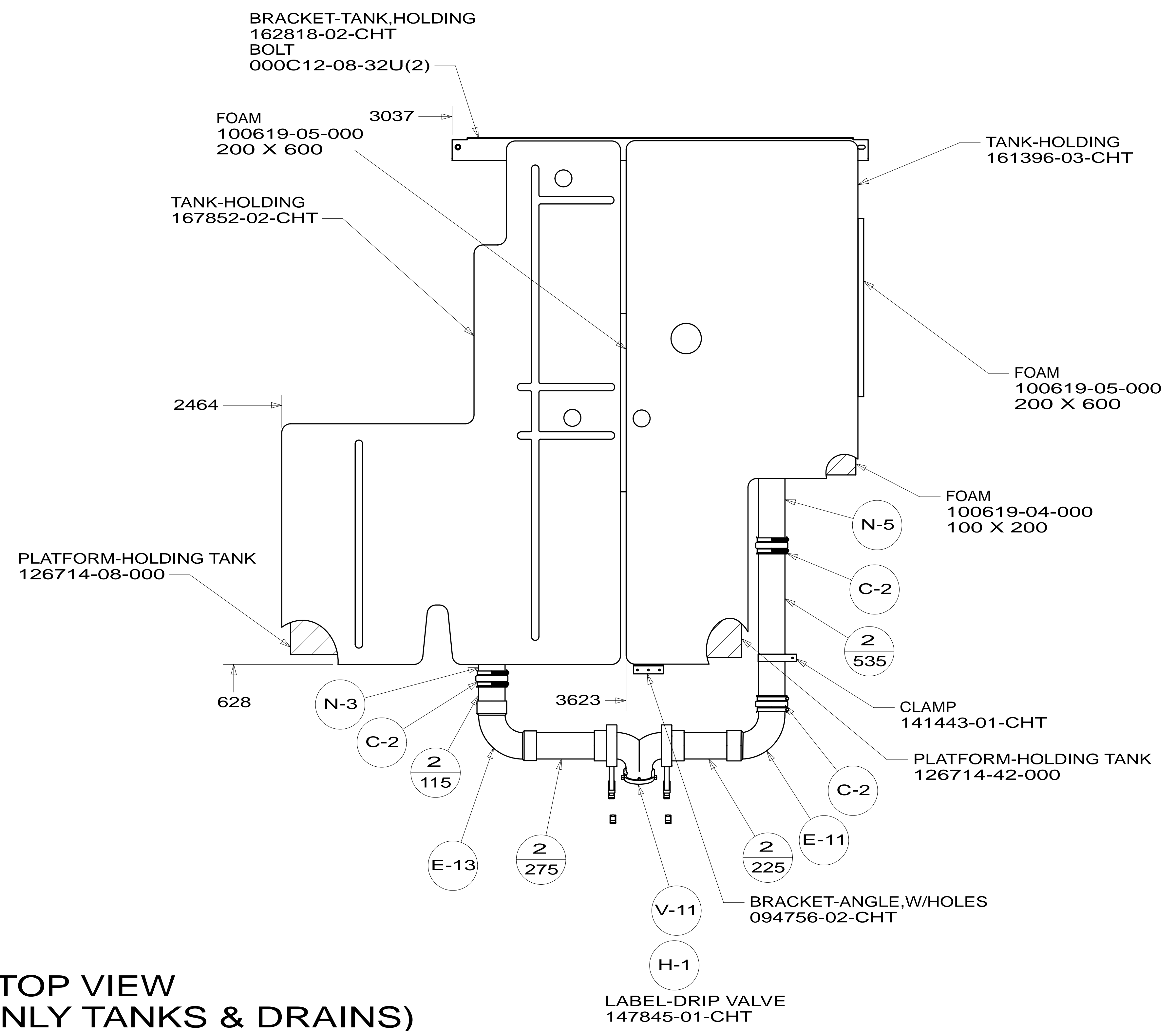

FIRST USED	13 J35P		
TITLE:	DO NOT SCALE DRAWING		
	DRAINAGE SYSTEM INSTL		
SHEET 4	PART NO	181008	REV
			1 23-Apr-2013

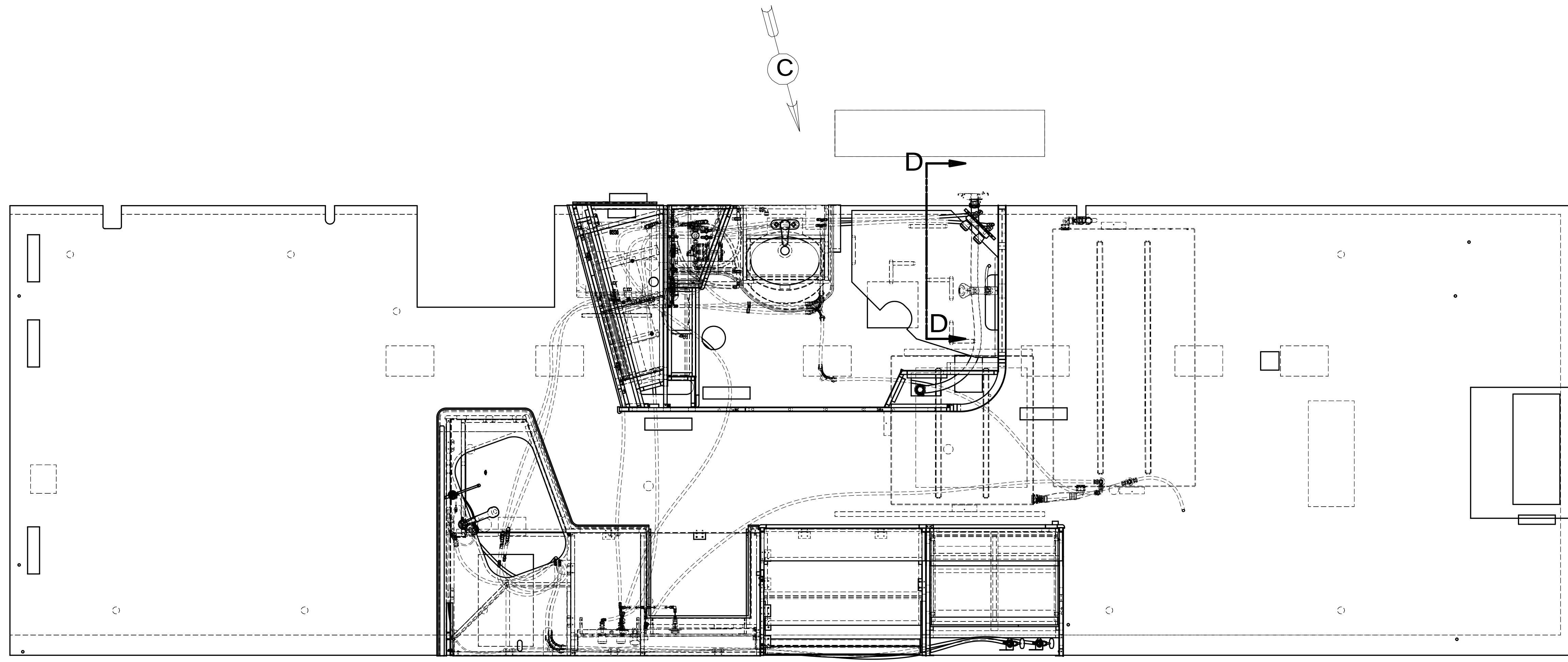

- (144) REFRIGERATOR-DOUBLE DOOR
- (79W) REFRIGERATOR-4 DOOR
- (15U) REFRIGERATOR/FRZR W/ICEMAKER

9. FLUSHING SYSTEM REQUIRES 125697-06-000 INSTRUCTION SHEET.
8. ALL CRIMP FITTINGS TO 1/2" PEX TUBING REQUIRE 1/2" CLAMP 140171-03-000.
7. ALL CRIMP FITTINGS TO 5/8" PEX TUBING REQUIRE 5/8" CLAMP 140171-04-000.
6. LABEL HOT AND COLD SUPPLY TUBES AND TAPE FITTING TO TUBE BEFORE CABINET SET TO PREVENT MOVEMENT.
5. ADD PIPE WRAP (LADDER SCRAP 110157-02-000) INSULATION.
4. ADD TEFLON TAPE 010405-02-000.
3. ALL TUBING TO BE SECURED AT 1200 INTERVALS MAXIMUM WITH CLAMP 010495-01-000 AND SCREW 000G67-10-12U OR EQUIVALENT.
2. TUBING TO BE INSTALLED WITH SUFFICIENT SLOPE TO PROVIDE DRAINAGE TO NEAREST VALVE.
1. PLASTIC FITTINGS TO BE SEALED WITH SEALANT 084456-01-000.

NOTES:

		COPYRIGHT 2012 WINNEBAGO INDUSTRIES, INC.	
DFTR	ORIG. DATE	ALL DIMENSIONS ARE IN MILLIMETERS	
CHKR			
P.E.			
M.E.	FIRST USED	13 J35P	
DSNR			
UNSPECIFIED TOLERANCES ARE:		MATERIAL:	
WHOLE DIM (X)	: 3		
ONE-PLACE (X.X)	: 1.5		
TWO-PLACE (X.XX)	: 0.50		
ANGLE	: 1°		
THIRD ANGLE PROJECTION			
DO NOT SCALE DRAWING		REFER TO ES0018 FOR FASTENER TIGHTENING GUIDELINES	
TITLE: WATER SYSTEM INSTL			
SHEET 1 OF 4	PART NO	181017	REV
REF:	1	09-Jul-2012	

FOR WATER CALLOUTS SEE DWG NO 116230-01-000

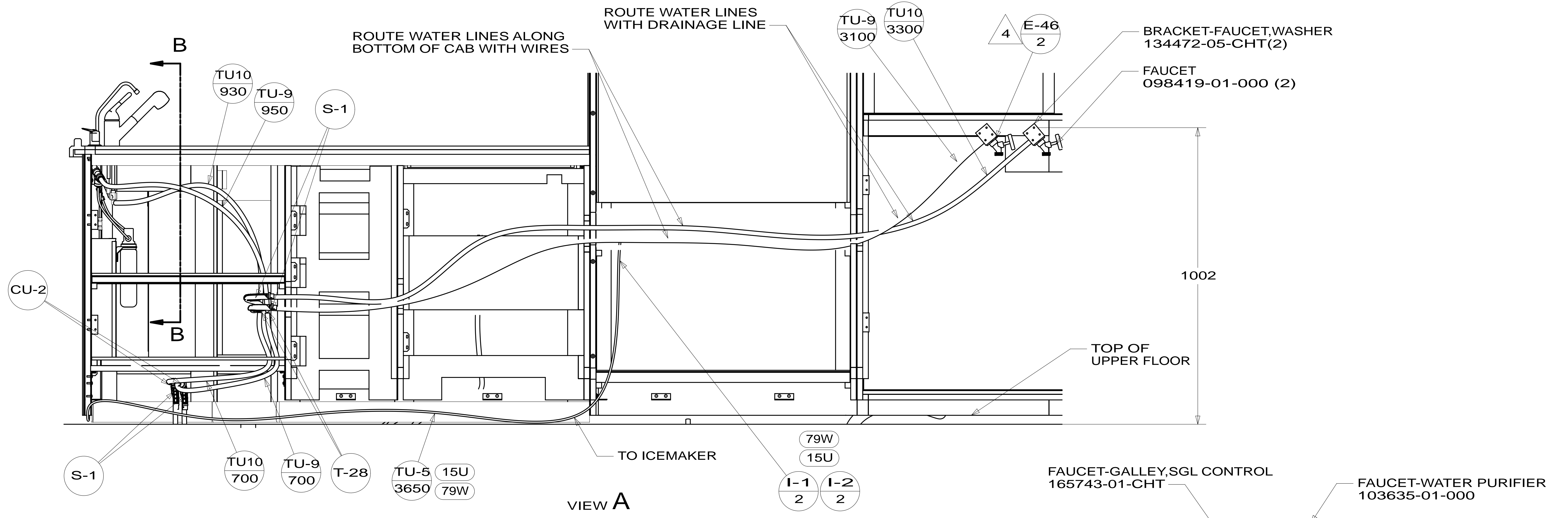

VIEW A

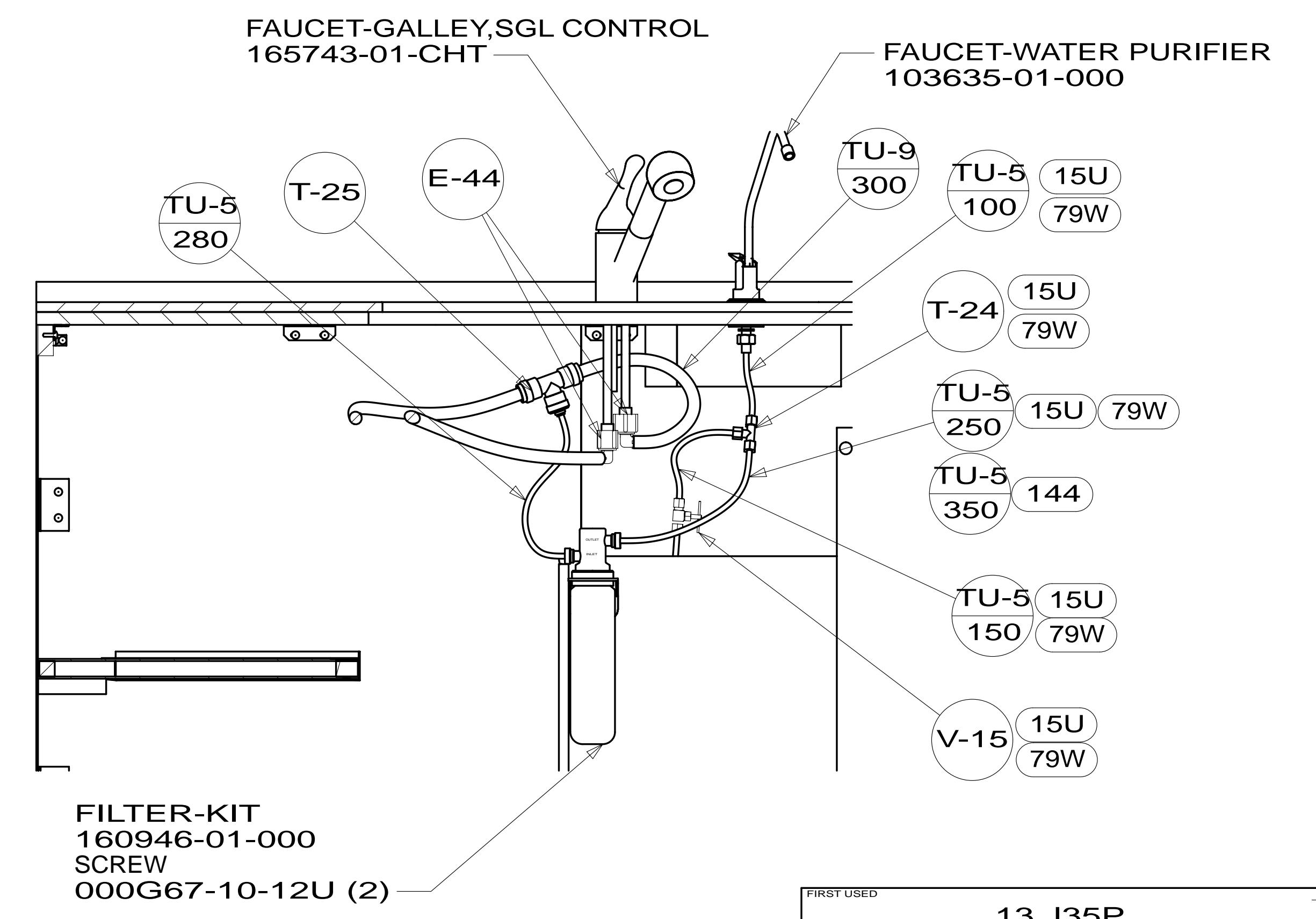

SECTION B-B

FIRST USED	13 J35P	
TITLE:	DO NOT SCALE DRAWING	
SHEET 2	PART NO	181017
	REV	09-Jul-2012

PANEL-SHOWER
167738-02-CHT

4 E-44

TU-9
1900

TU10
1850

FAUCET-LAV
165730-01-CHT

E-46

BREAKER-VACUUM
125697-04-000
MUST BE MOUNTED ABOVE
TOILET FLOOD LEVEL
CHECK VALVE
125697-03-000 4

A-27

R-4

R-4

T-28

TU-9
605

TU10
610

E-21

DETAIL J

VIEW C

348 SHOWER-HAND HELD
176668-01-CHT

200

F-2

SECTION D-D
(ROTATED)

TO TOILET

TU-9
3450

TU-9
1640

E-44

TU-8
675

T-28

S-1

S-1

T-29

T-29

TU-9
160

DETAIL J
(SHOWN W/OUT CABINET)

FIRST USED	13 J35P		
TITLE:	DO NOT SCALE DRAWING		
	WATER SYSTEM INSTL		
SHEET 3	PART NO	181017	REV
			09-Jul-2012

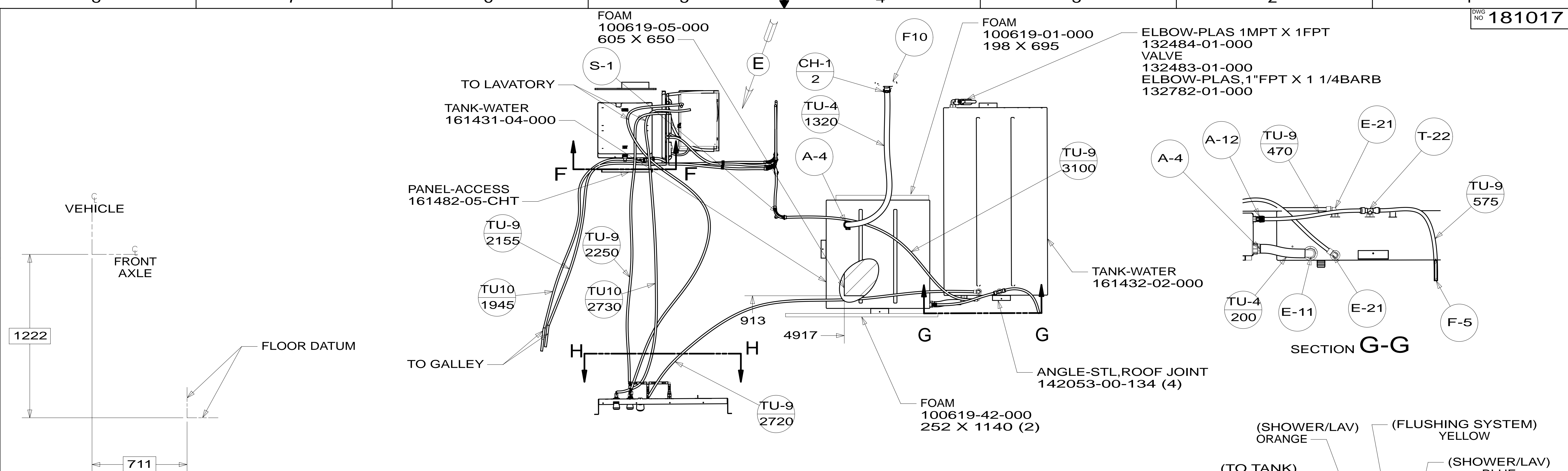

TOP VIEW LINES UNDER FLOOR SHOWN ONLY

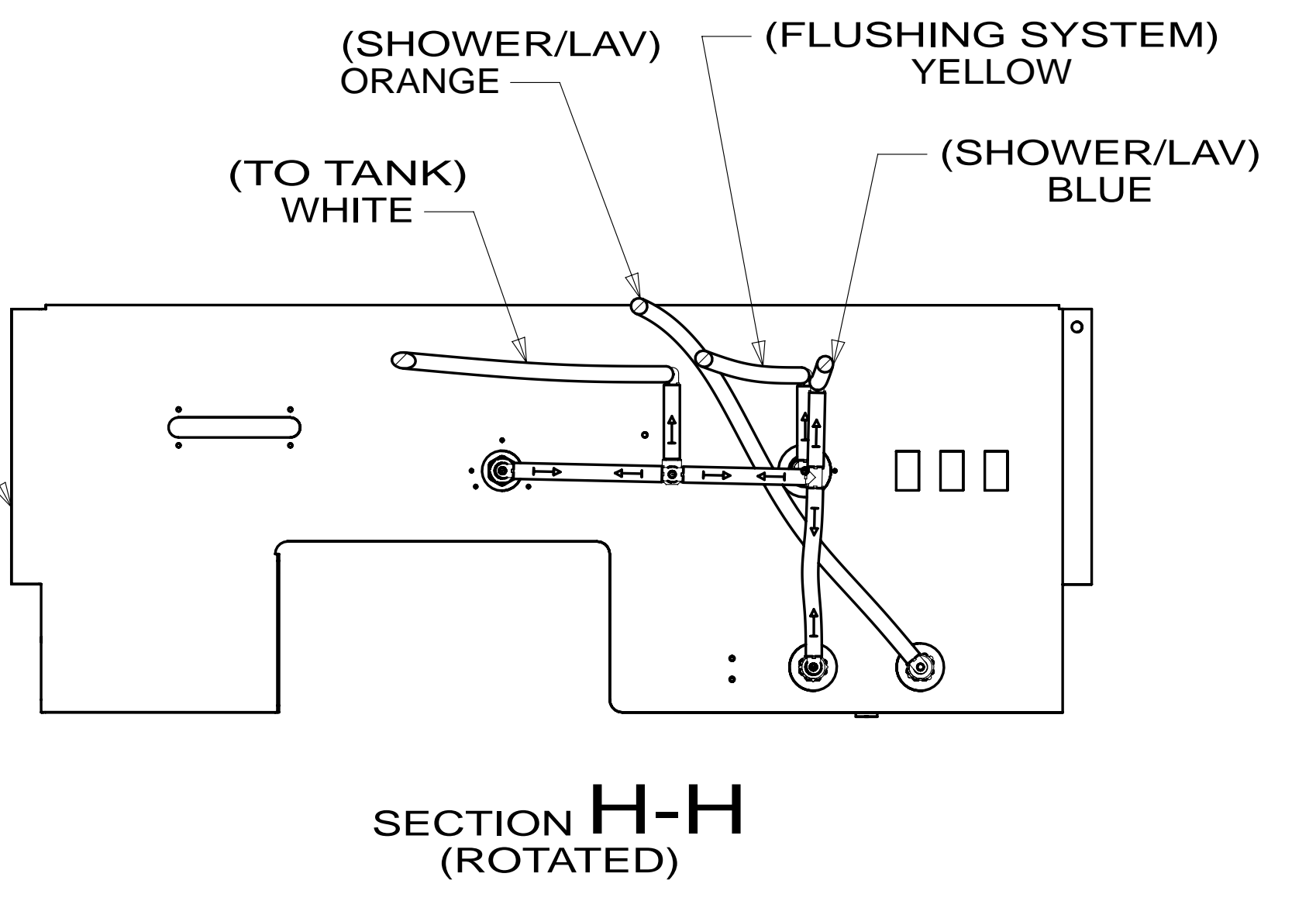
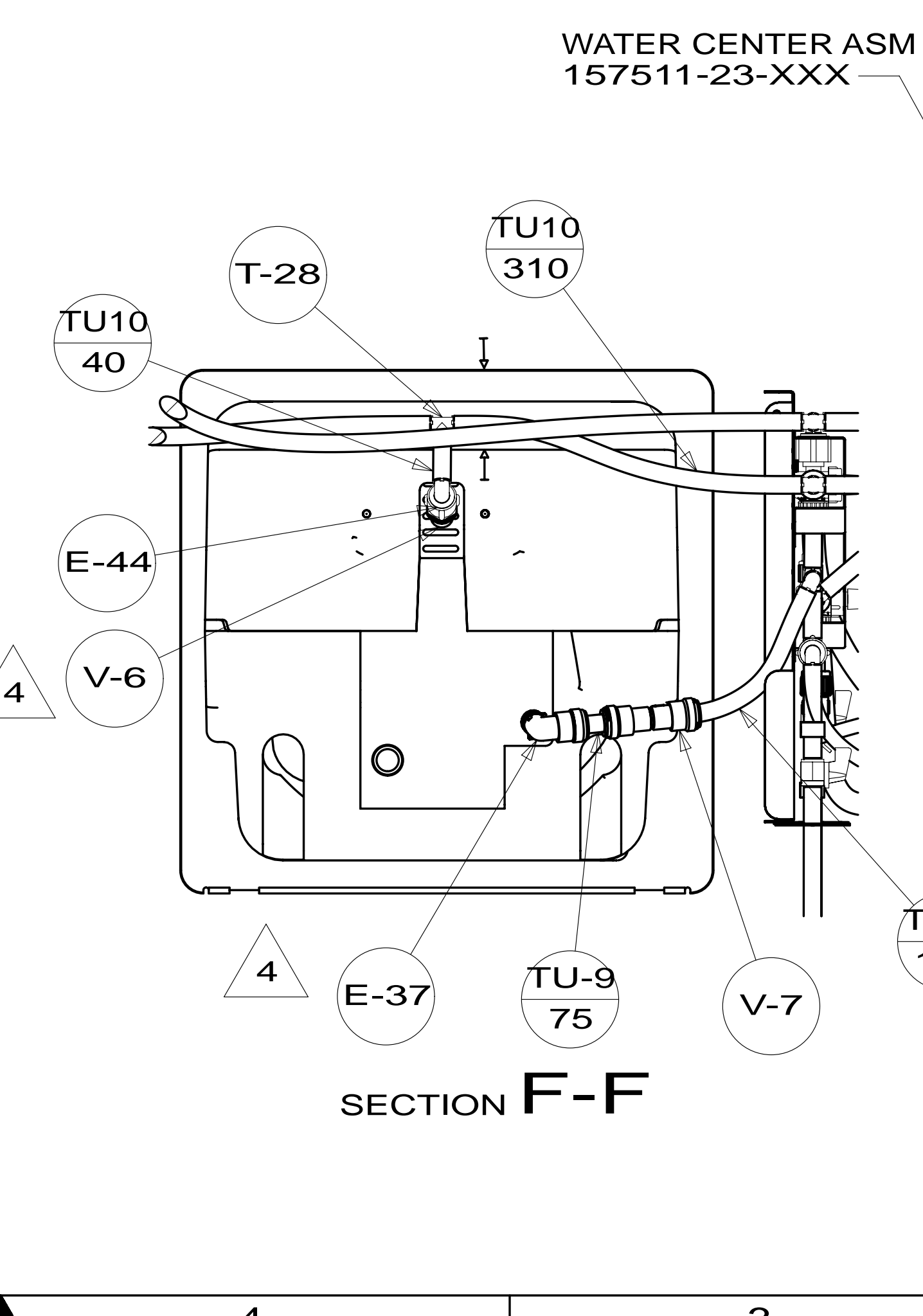
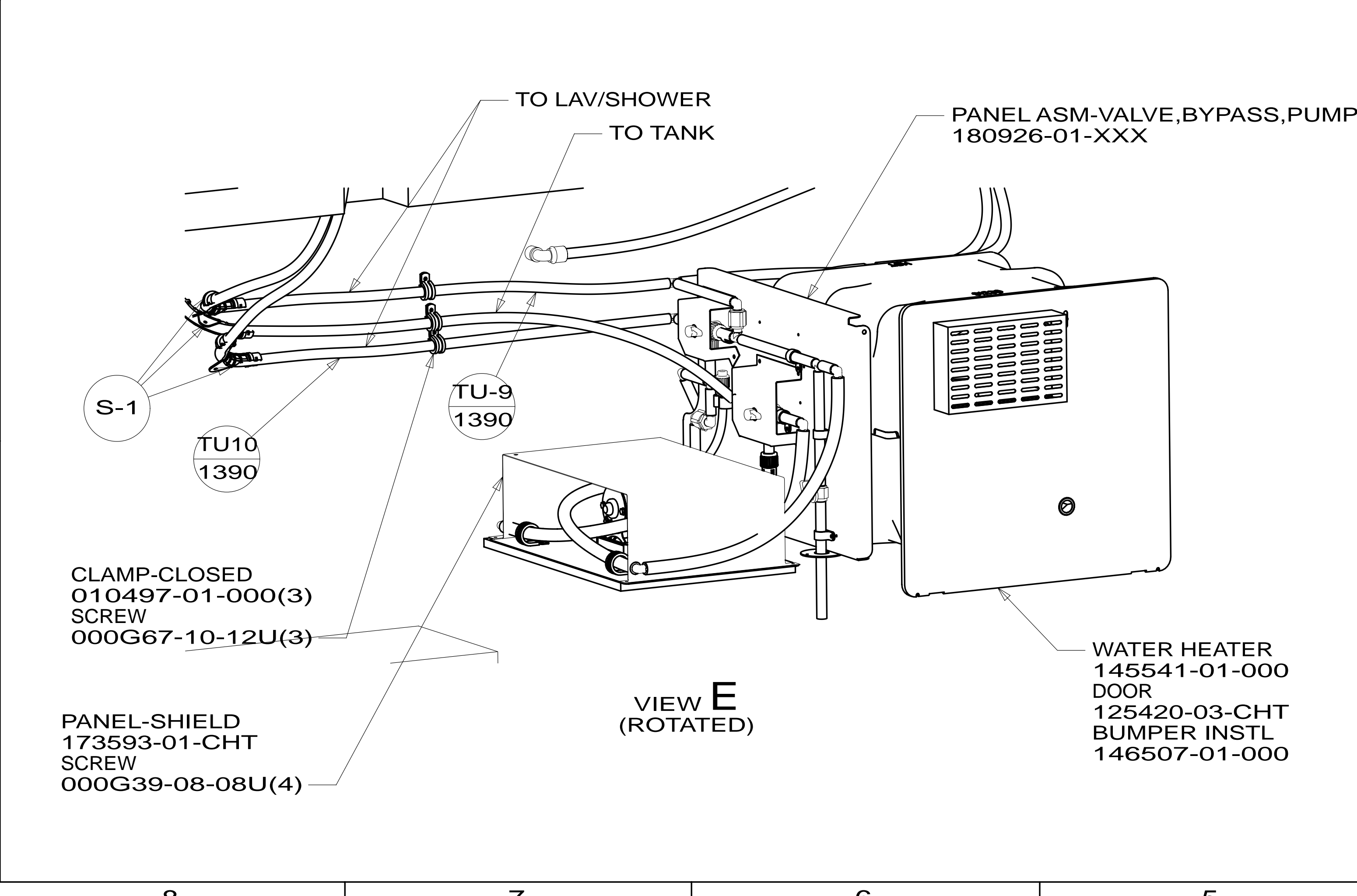

FIRST USED	13 J35P	
DO NOT SCALE DRAWING		
TITLE: WATER SYSTEM INSTL		
SHEET 4	PART NO 181017	REV