

FRONT
OF
COACH

265 CODES/STDS-CSA/CMVSS
1B1 CODES/STANDARDS-USA

WINNEBAGO INDUSTRIES		COPYRIGHT 2012 WINNEBAGO INDUSTRIES, INC.	
DTR	ORIG. DATE	ALL DIMENSIONS ARE IN MILLIMETERS	
CHKR			
P.E.			
M.E.	FIRST USED		
DSNR		13 E30T	
UNSPECIFIED TOLERANCES ARE:		MATERIAL:	
WHOLE DIM (X)	: 3		
ONE-PLACE (X.X)	:		
TWO-PLACE (X.XX)	:		
ANGLE	:		
THIRD ANGLE PROJECTION			
DO NOT SCALE DRAWING		REFER TO ES0018 FOR FASTENER TIGHTENING GUIDELINES	
TITLE: DRAINAGE SYSTEM INSTL			
SHEET 1 OF 4	PART NO	182379	REV
REF:	1	2/13/2012	

- NOTES:
- 6 VENT PIPE MUST PROJECT 51 MIN AND 64 MAX ABOVE ROOF FOR PROPER FIT AND FUNCTION.
 - 5. SEAL AROUND SHOWER WITH SILICONE.
 - 4. SECURE VENT TUBES TO FLOOR WITH BRACKET 136878-01-CHT. CLAMP 062401-02-000 AND SCREW 000G67-10-12U.
 - 3. ALL PIPE AND FITTINGS TO BE ASSEMBLED WITH SOLVENT 004020-01-000 (US), 004020-02-000 (CAN).
 - 2. SLOPE OF TRAP ARM MUST BE 6 PER 305 mm.
 - 1. SLOPE OF HORIZONTAL PIPING TO BE MIN 3 PER 305 mm.

FOR
DRAINAGE
CALLOUTS
SEE DWG NO
116229-01-000

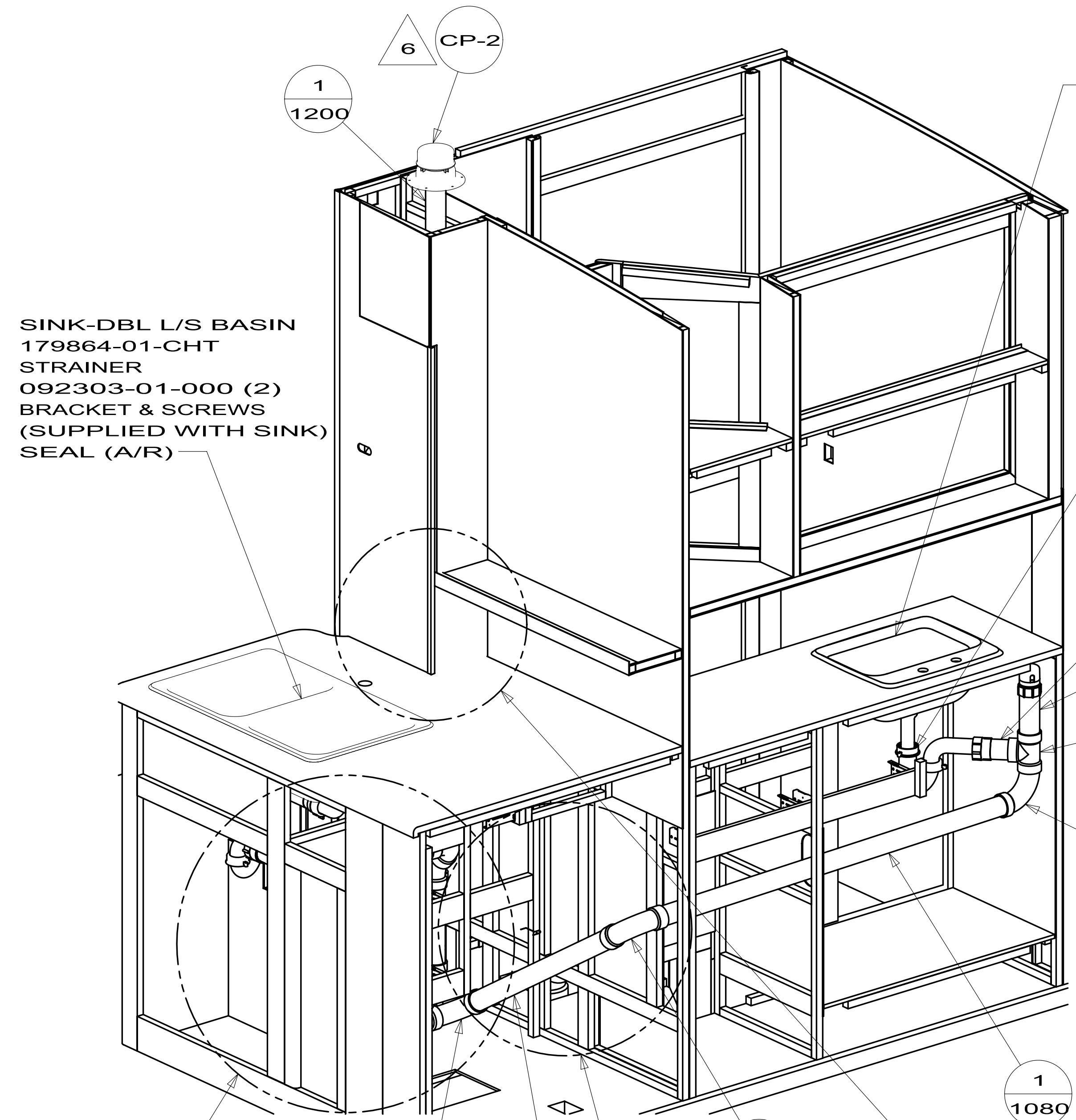

SINK-DBL L/S BASIN
179864-01-CHT
STRAINER
092303-01-000 (2)
BRACKET & SCREWS
(SUPPLIED WITH SINK)
SEAL (A/R)

SINK
096927-01-CHT
SEAL
091255-02-000 (A/R)

- P-1 1B1
- P-3 265
- A-15 1B1

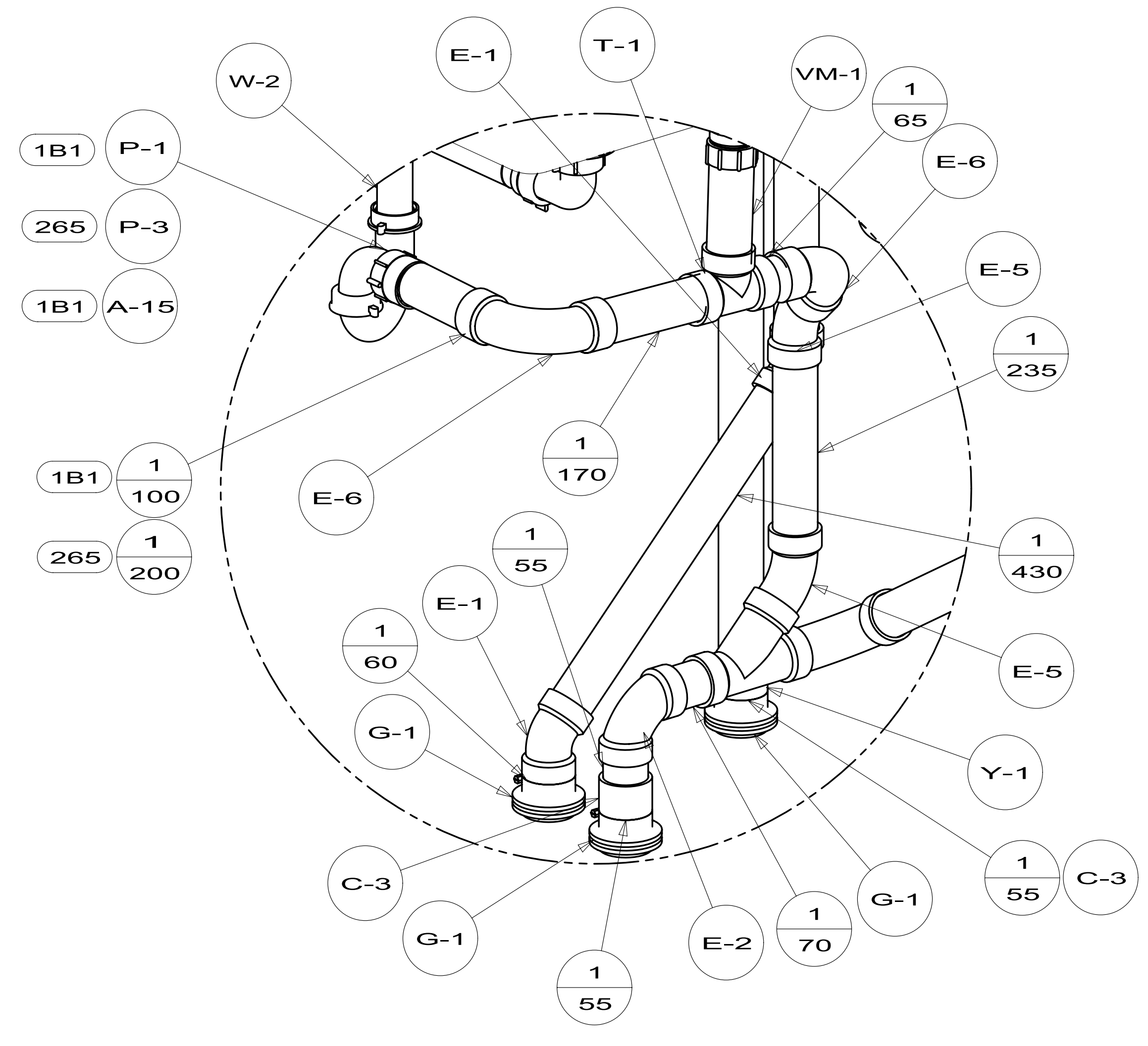

DETAIL B
(SHOWN W/OUT CABINETS AND FLOOR)

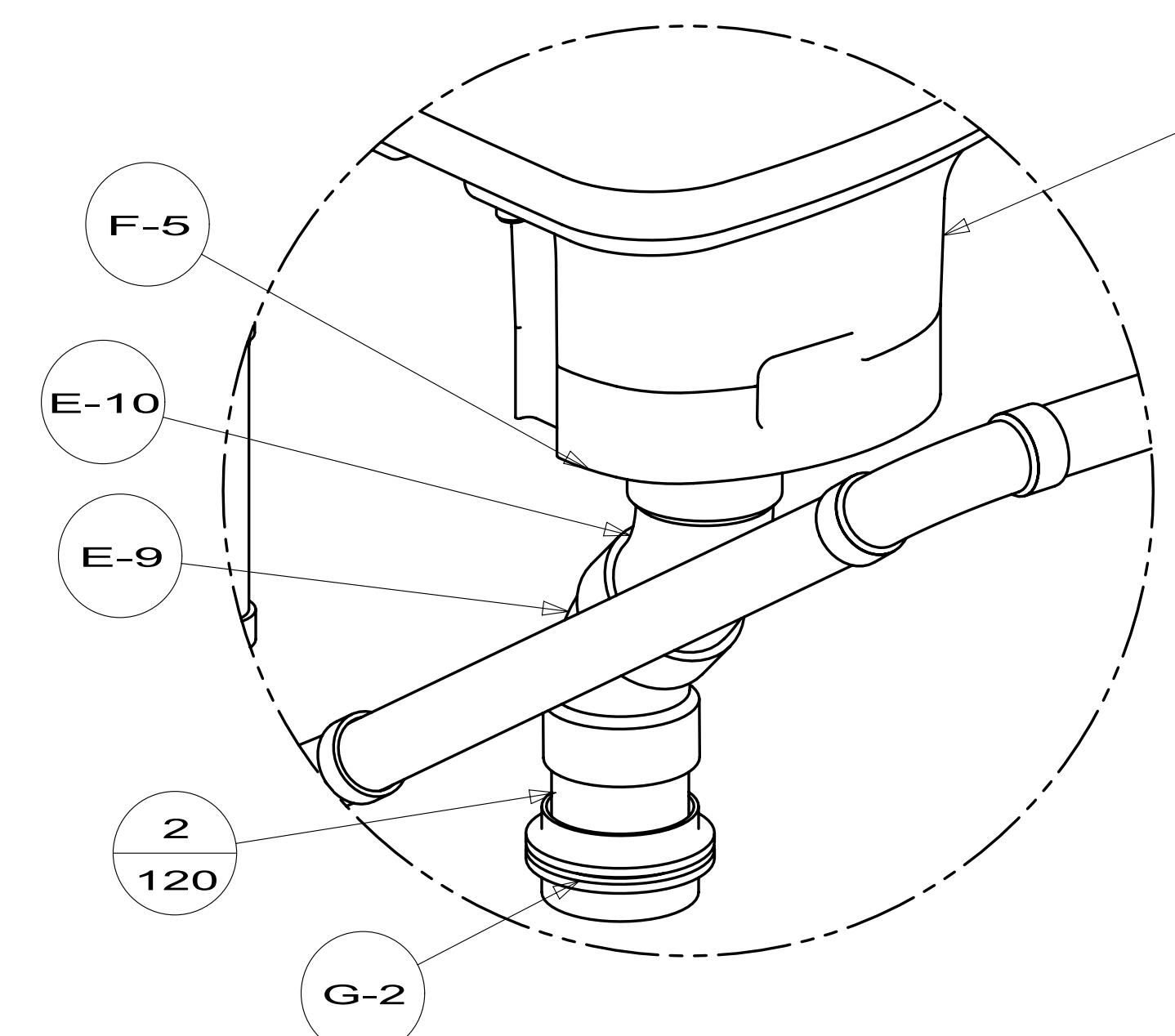

DETAIL C
(SHOWN W/OUT CABINETS AND FLOOR)

TOILET, LOW
147421-05-CHT
(FOOT FLUSH)
SCREW
087721-01-000 (6)

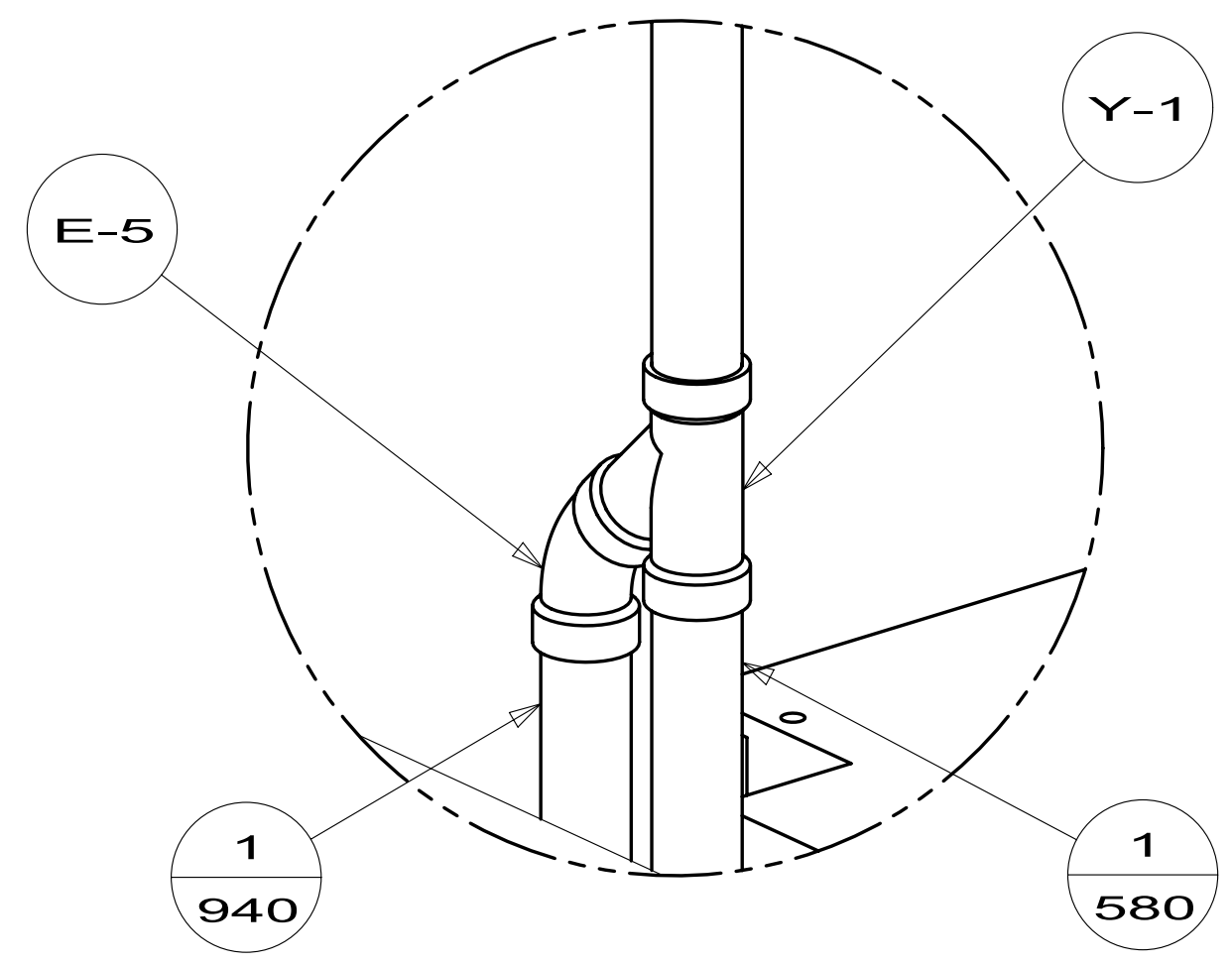

DETAIL D
(SHOWN W/OUT CABINETS)

VIEW A

DETAIL B

DETAIL C

DETAIL D

FIRST USED	13 E30T	
TITLE:	DO NOT SCALE DRAWING	
	DRAINAGE SYSTEM INSTL	
SHEET 2	PART NO 182379	REV

- SHOWER INSTL-ENCLOSURE
- 147936-04-000
- WASHER-RUBBER
- 127440-02-CHT
- SEALER
- 069640-01-000
- STRAINER
- 066440-01-000
- TAIL PIECE
- 011069-02-000
- NUT
- 130403-01-000

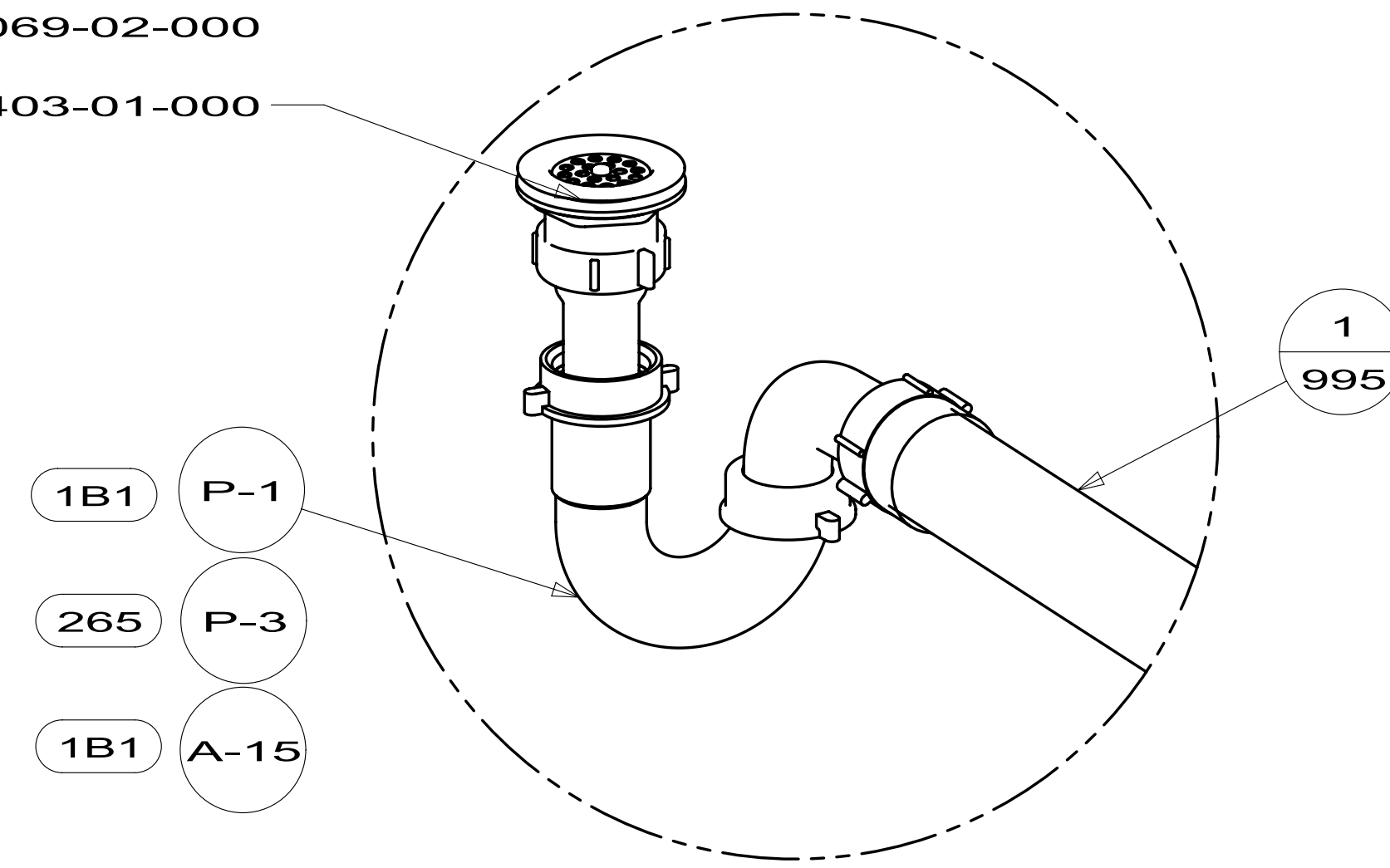

DETAIL F
(SHOWN W/OUT SHOWER PAN AND FLOOR)

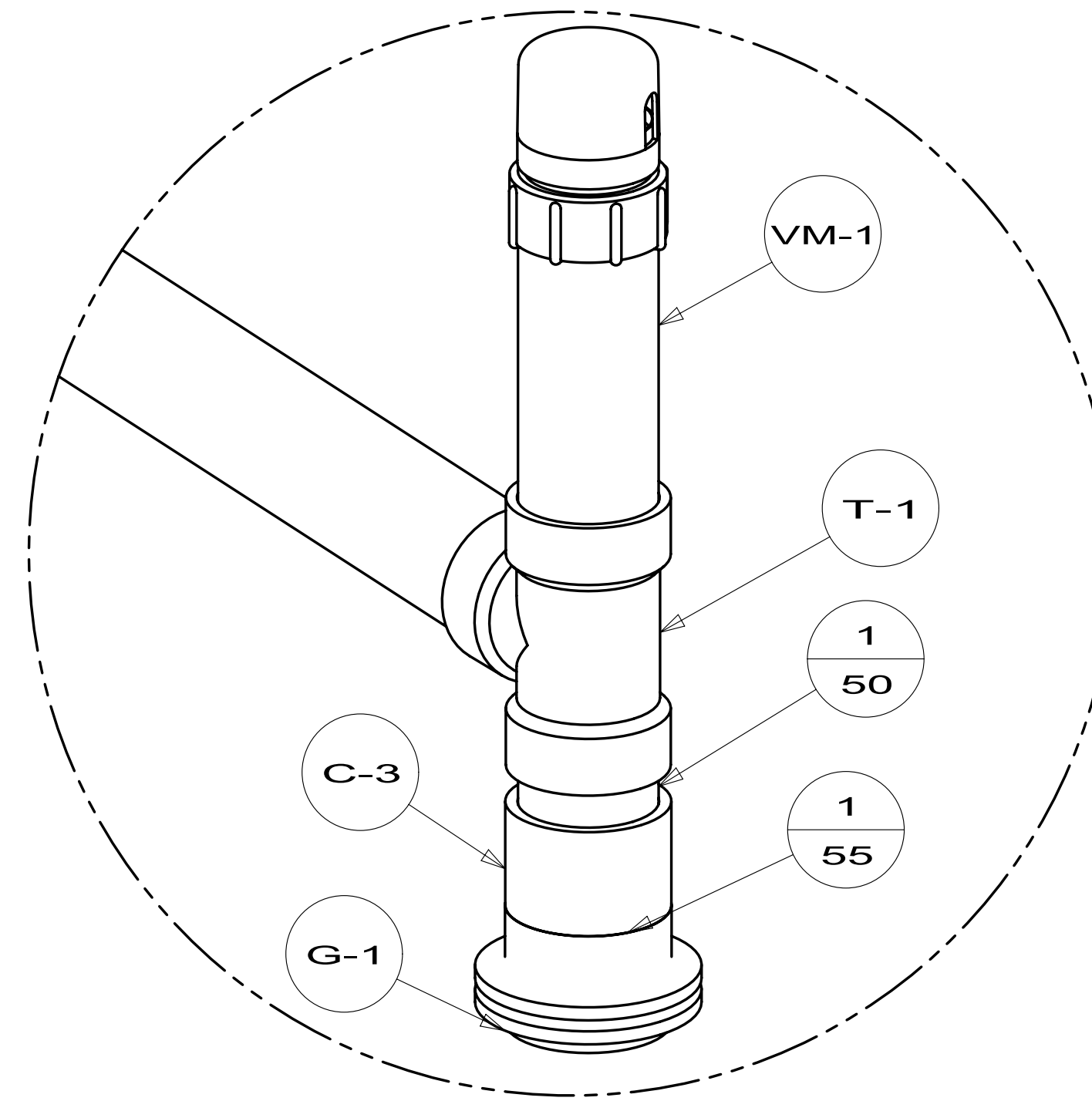

DETAIL G
(SHOWN W/OUT CABINETS AND FLOOR)

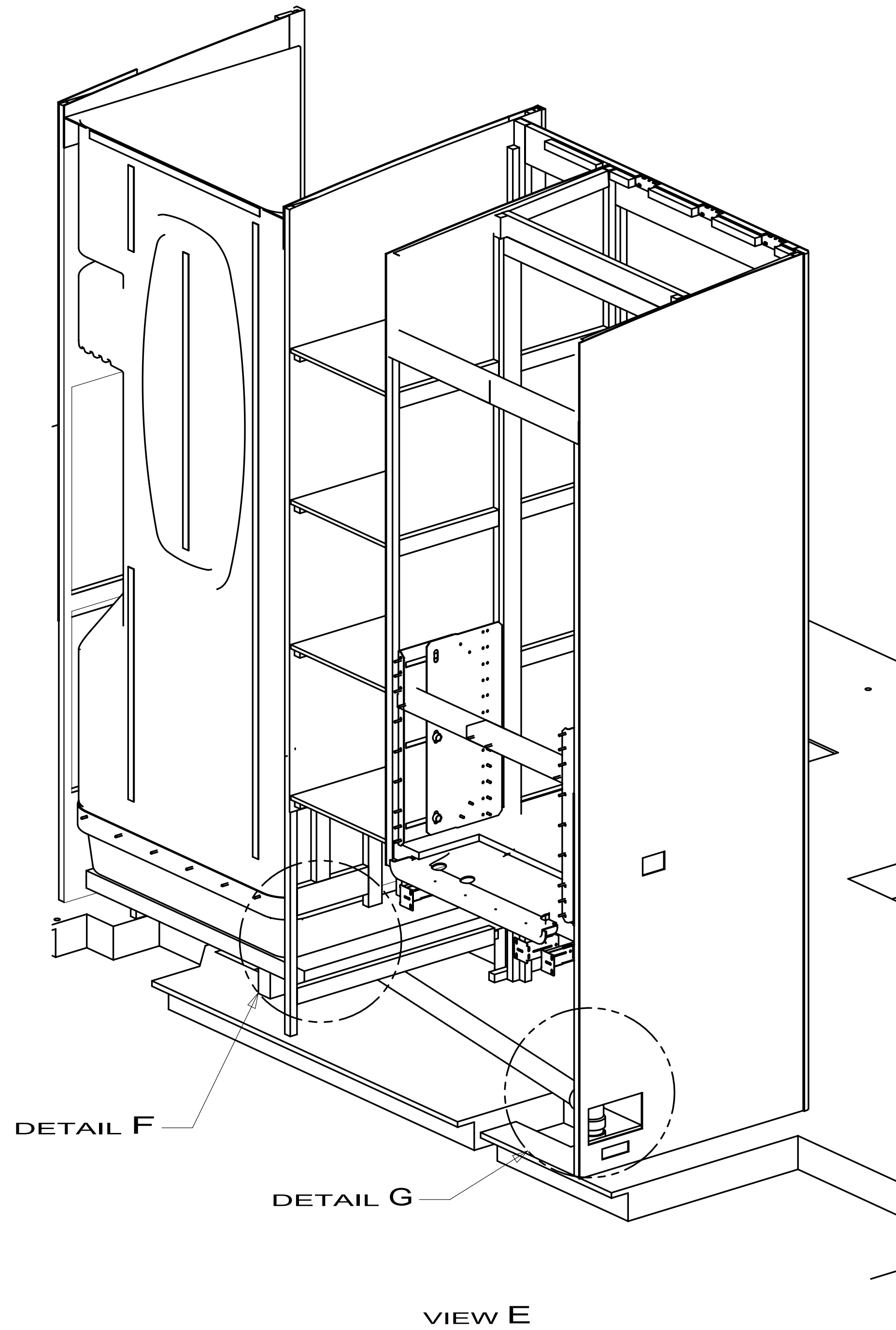

FIRST USED	13 E30T	
DO NOT SCALE DRAWING		
TITLE: DRAINAGE SYSTEM INSTL		
SHEET 3	PART NO 182379	REV

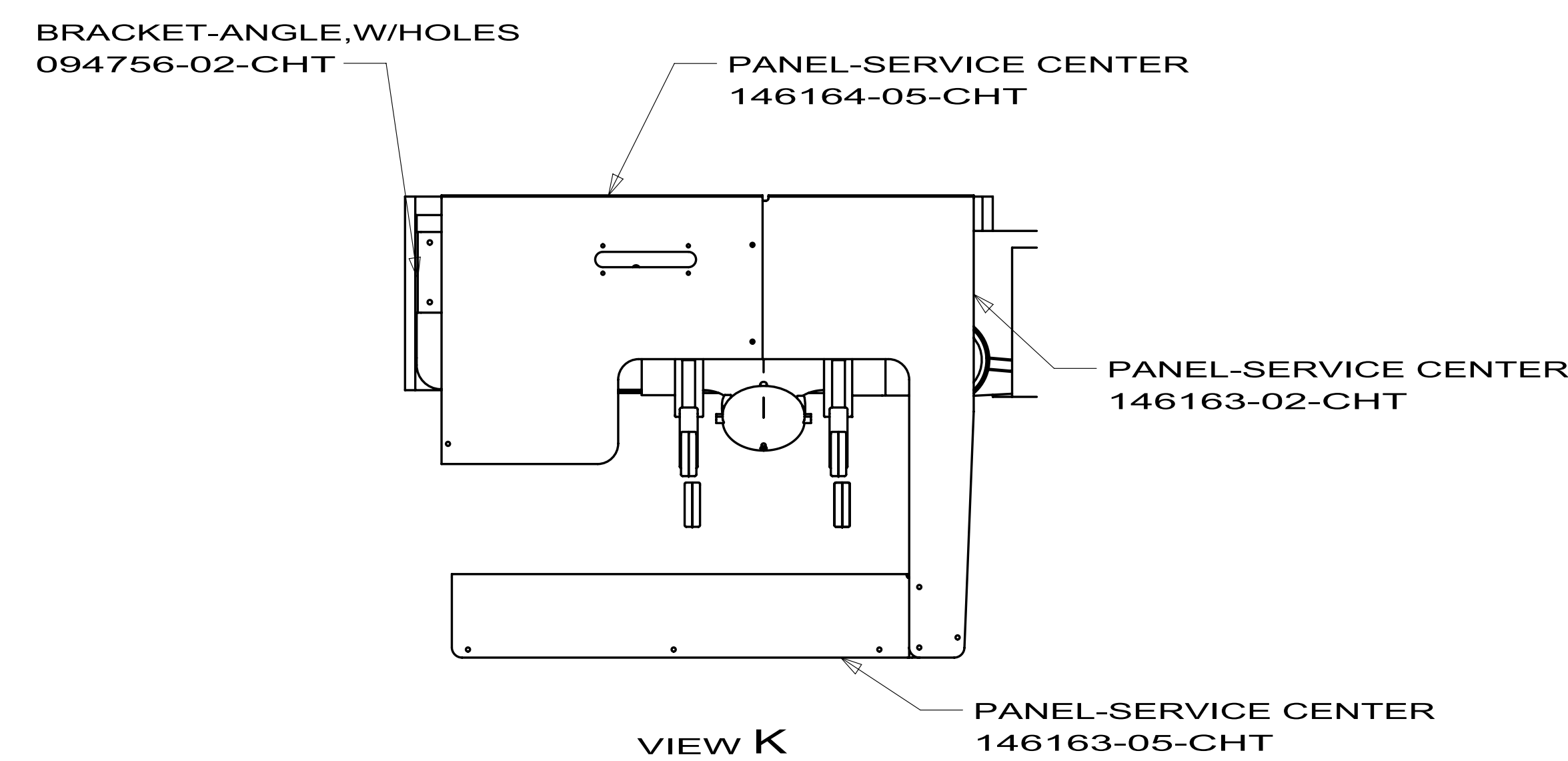
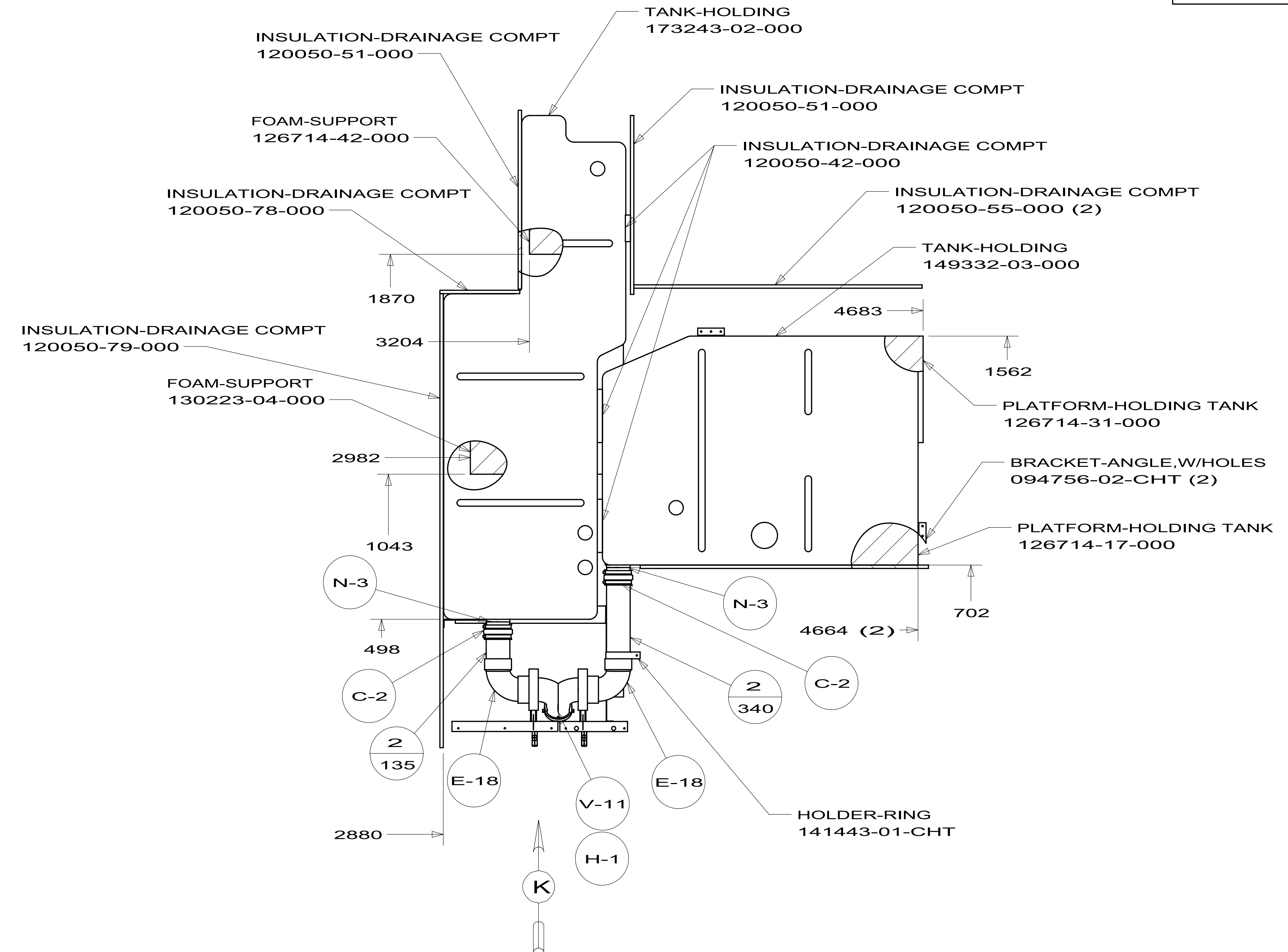
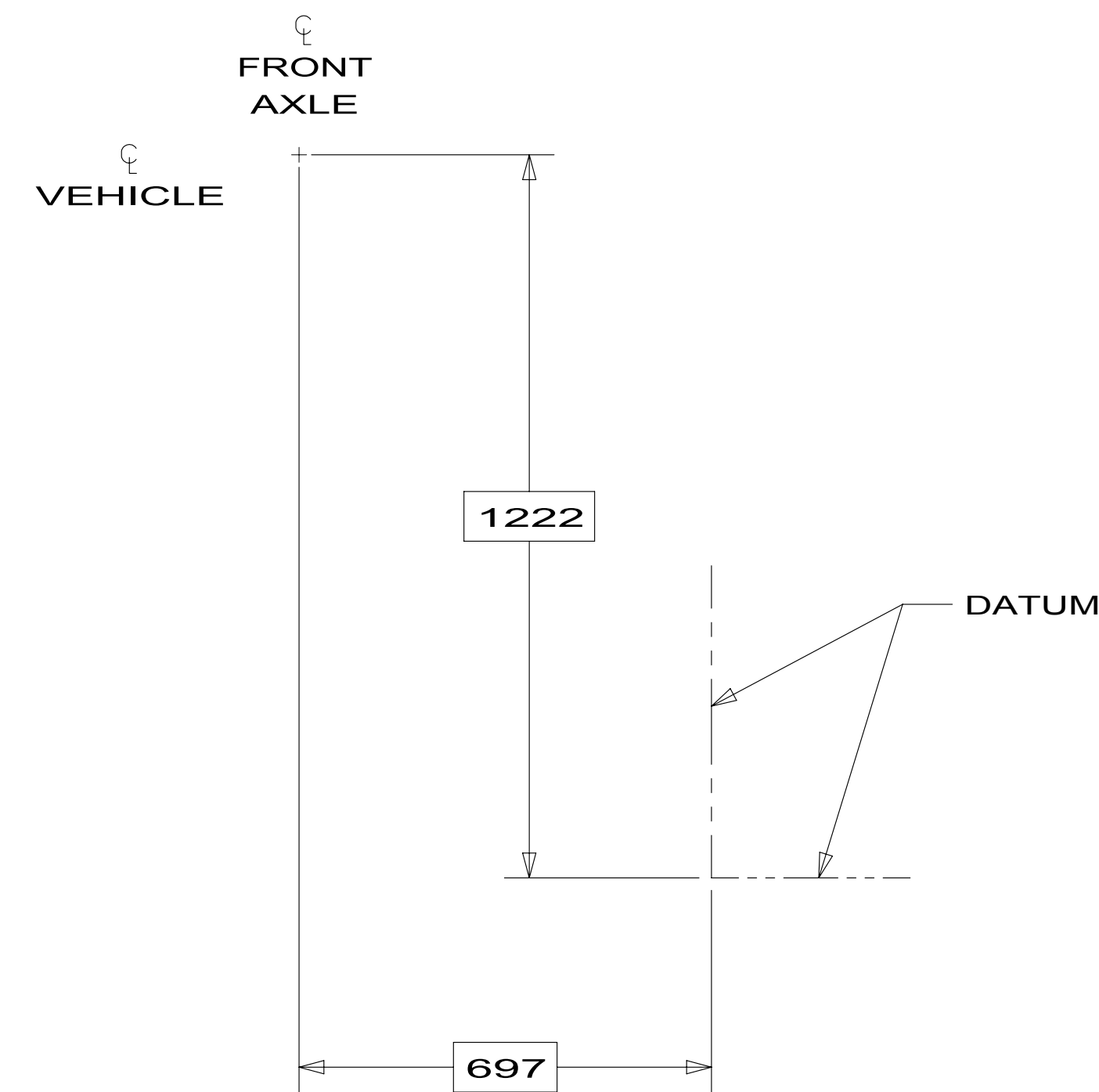

FIRST USED	13 E30T	
TITLE:	DO NOT SCALE DRAWING	
TITLE:	DRAINAGE SYSTEM INSTL	
SHEET 4	PART NO 182379	REV

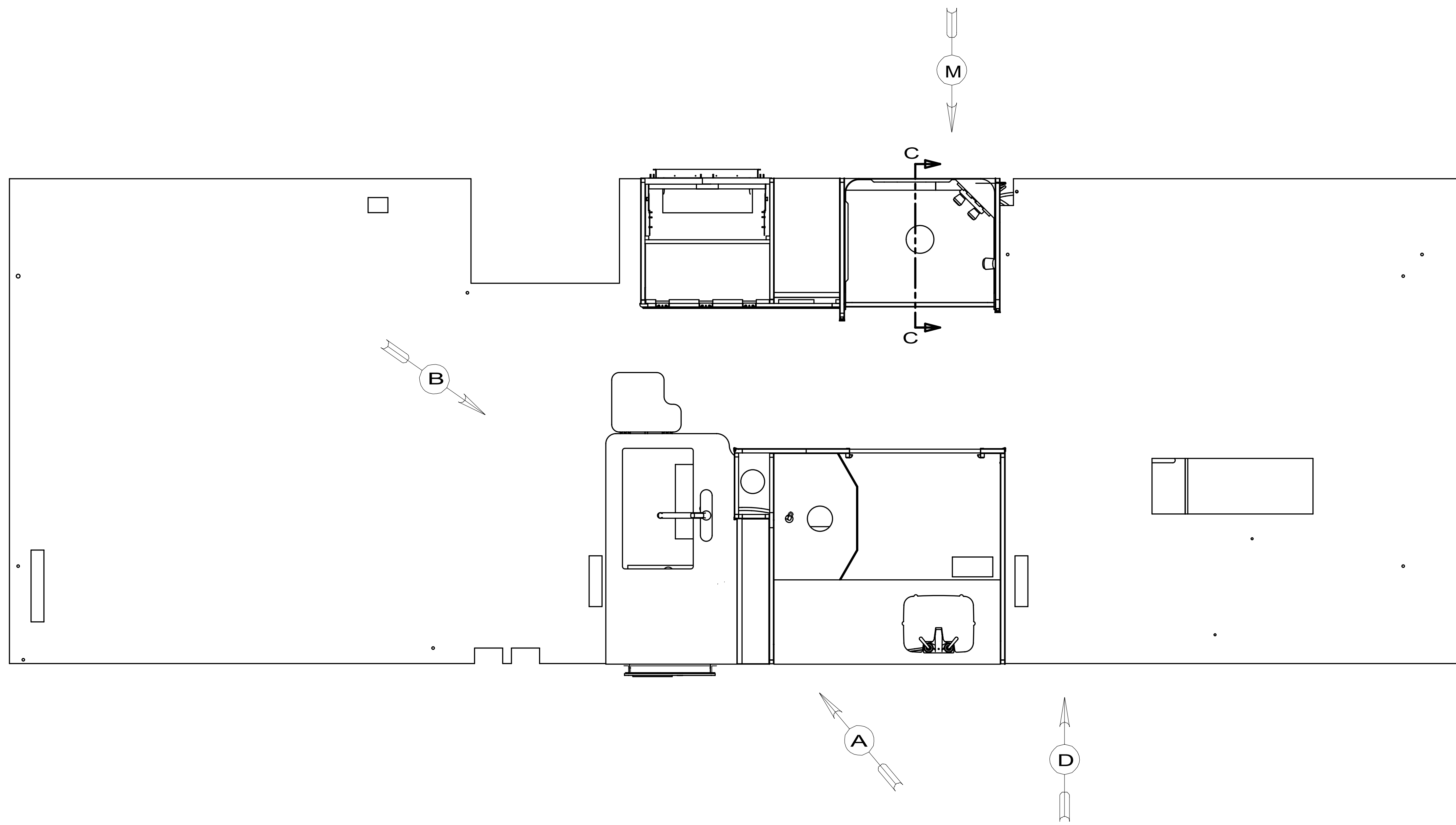

- 1J4 EXT WASH STATION - WITHOUT
- 64R EXTERIOR WASH STATION
- 53F WATER HEATER-ELEC. IGNITION
- 53D WTR HTR-6GAL/ELE/LP/MOTOR/RAID

9. FLUSHING SYSTEM REQUIRES 125697-06-000 INSTRUCTION SHEET.
8. ALL CRIMP FITTINGS TO PEX TUBING REQUIRE 1/2" CLAMP 140171-03-000.
7. ALL CRIMP FITTINGS TO PEX TUBING REQUIRE 5/8" CLAMP 140171-04-000.
- 6 LABEL HOT AND COLD SUPPLY TUBES AND TAPE FITTING TO TUBE BEFORE CABINET SET TO PREVENT MOVEMENT.
- 5 ADD PIPE WRAP (LADDER SCRAP 110157-02-000) INSULATION.
- 4 ADD TEFLON TAPE 010405-02-000.
3. ALL TUBING TO BE SECURED AT 1200 INTERVALS MAXIMUM WITH CLAMP 010495-01-000 AND SCREW 000G67-10-12U OR EQUIVALENT.
2. TUBING TO BE INSTALLED WITH SUFFICIENT SLOPE TO PROVIDE DRAINAGE TO NEAREST VALVE.
1. PLASTIC FITTINGS TO BE SEALED WITH SEALANT 084456-01-000.

NOTES:

		COPYRIGHT 2012 WINNEBAGO INDUSTRIES, INC.	
DTR	ORIG. DATE	ALL DIMENSIONS ARE IN MILLIMETERS	
CHKR			
P.E.			
M.E.	FIRST USED	13 E30T	
DSNR			
UNSPECIFIED TOLERANCES ARE: WHOLE DIM (X) : 3 ONE-PLACE (X.X) : 1.5 TWO-PLACE (X.XX) : 0.50 ANGLE : 1°		MATERIAL:	
THIRD ANGLE PROJECTION			
DO NOT SCALE DRAWING		REFER TO ES0018 FOR FASTENER TIGHTENING GUIDELINES	
TITLE: WATER SYSTEM INSTL			
SHEET 1 OF 4	PART NO	182378	REV
REF:	1	2/28/2012	

FOR
 WATER
 CALLOUTS
 SEE DWG NO
 116230-01-000

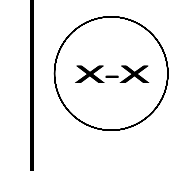

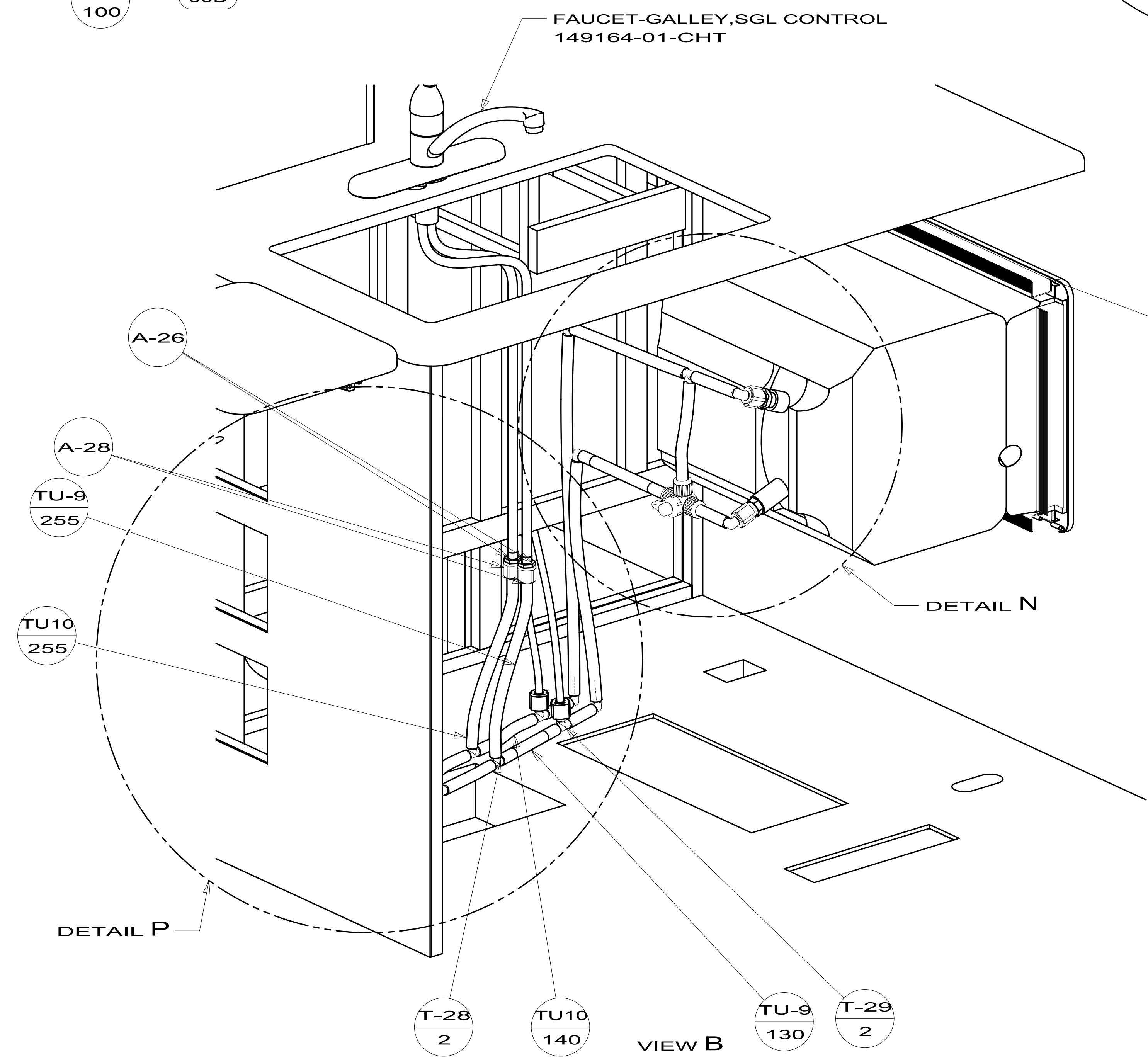
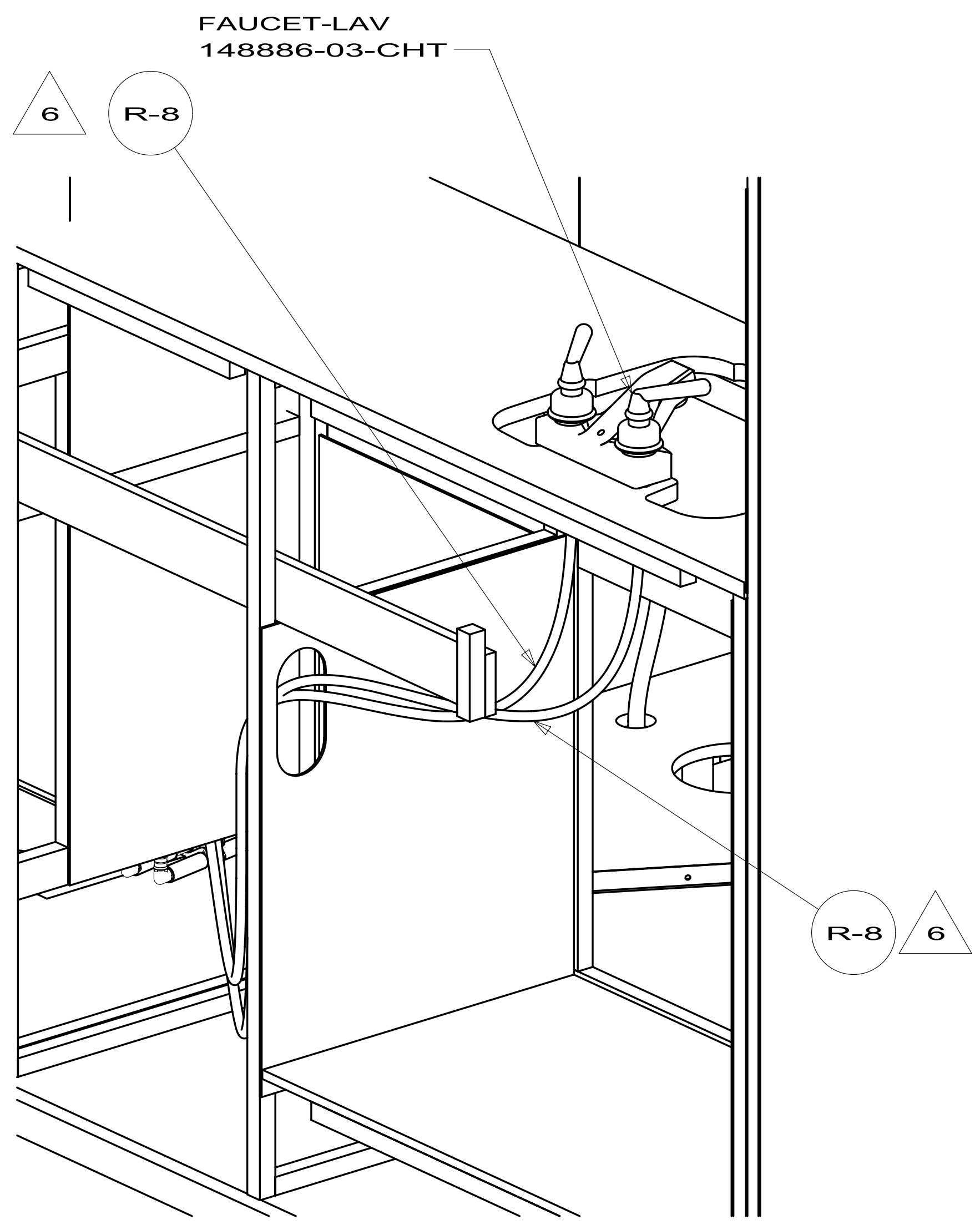
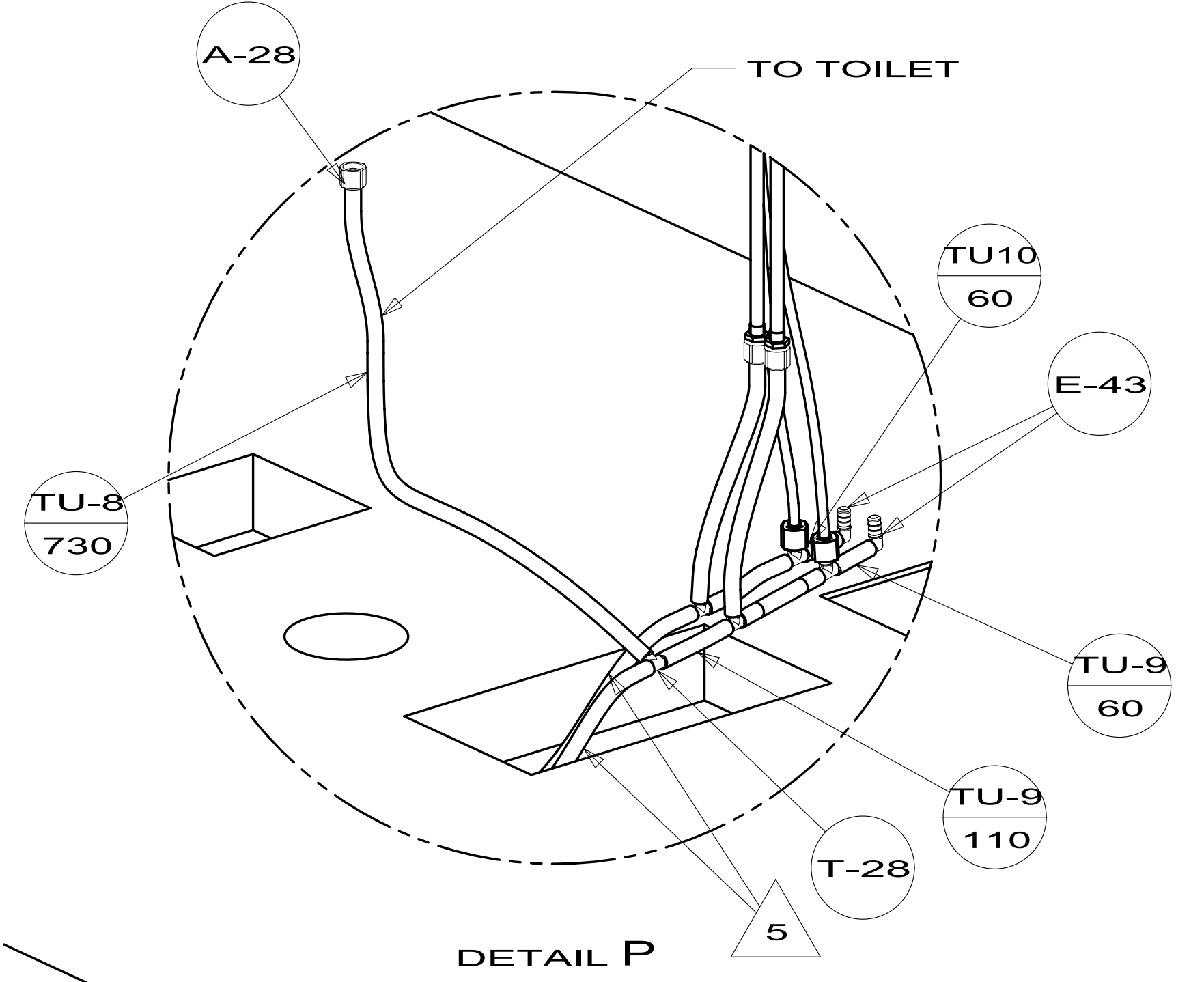
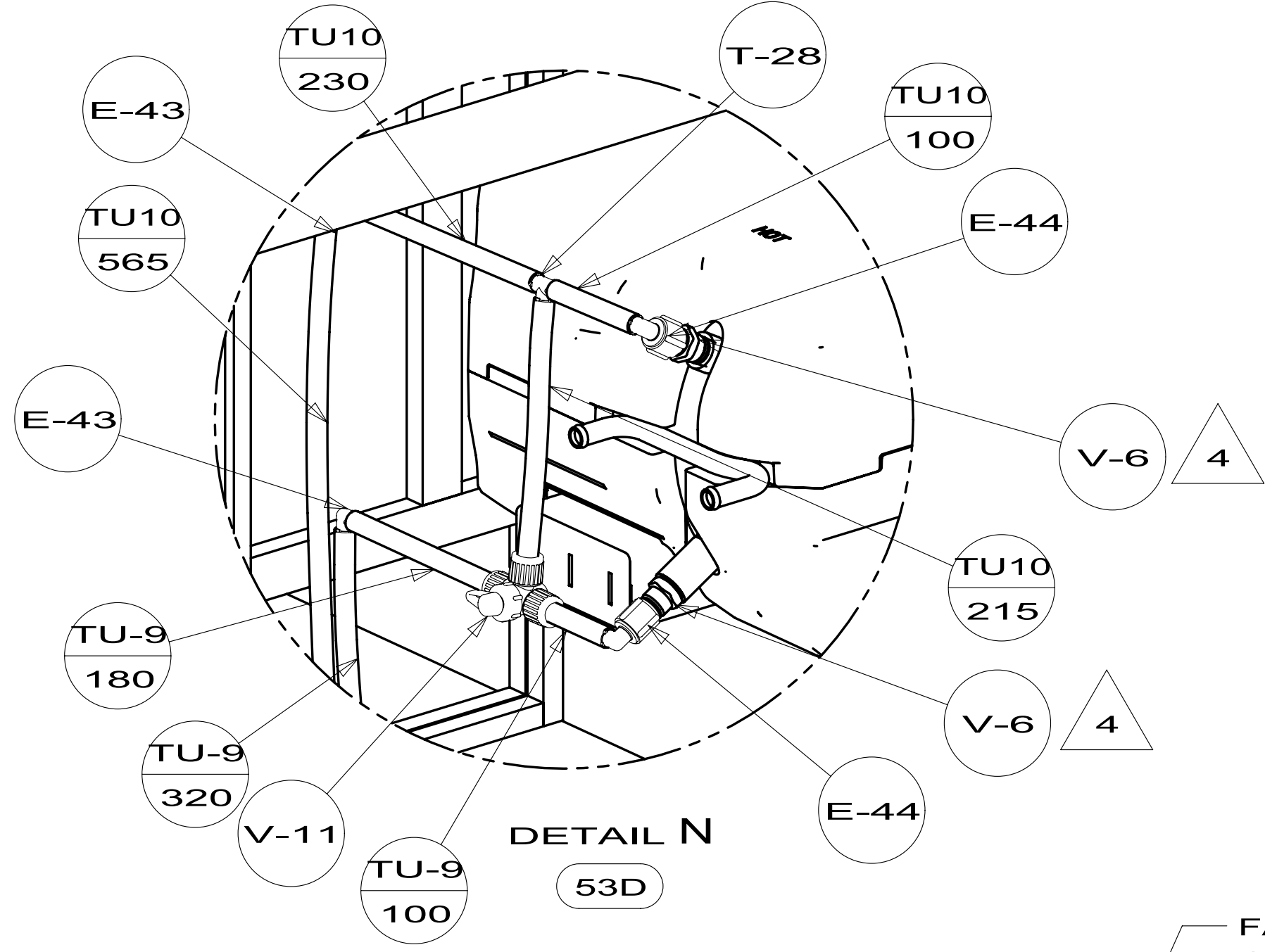
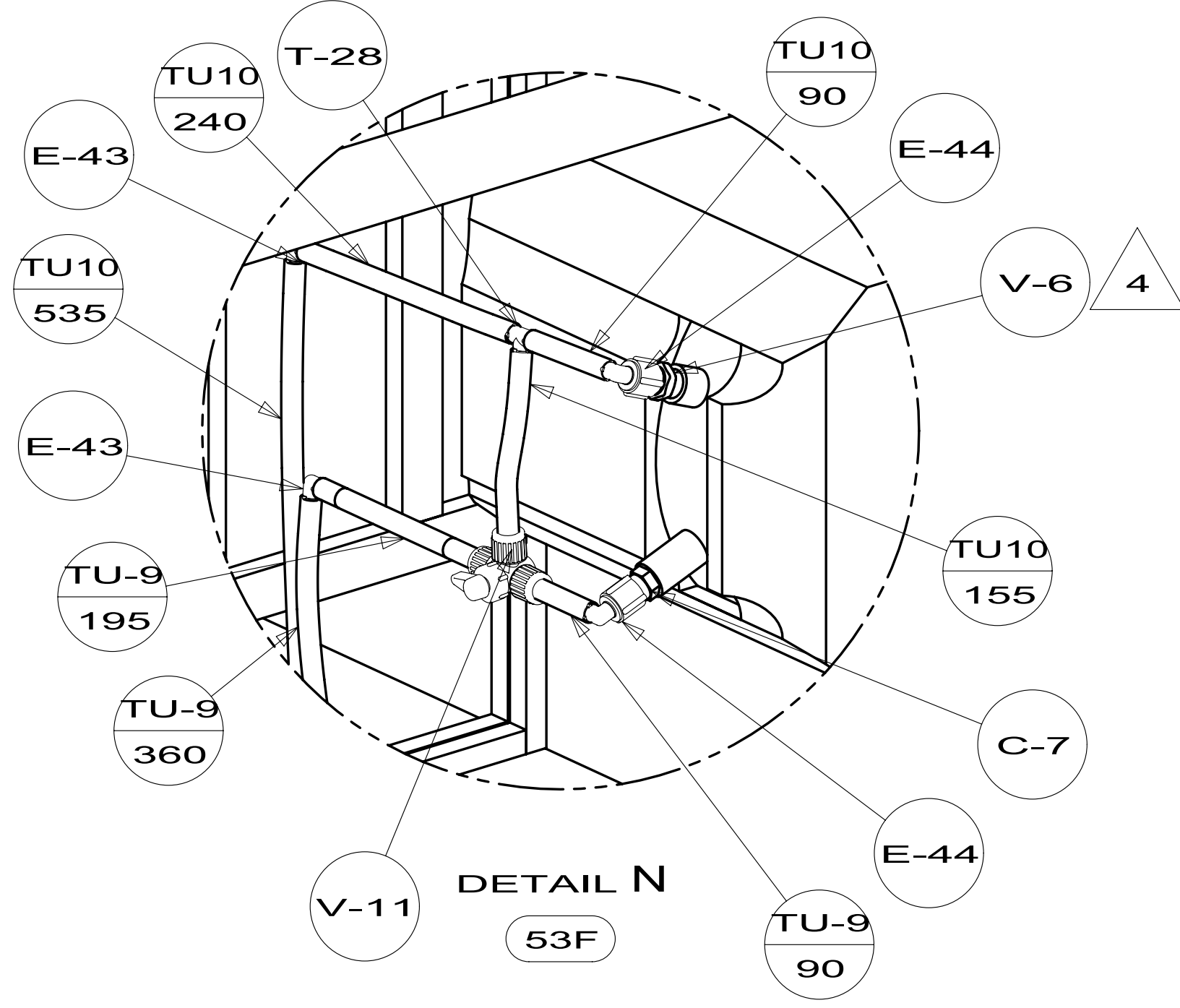

- WATER HEATER 53F
- 051391-03-000
- 145541-02-000
- DOOR 53D
- 125420-06-CHT
- CABLE
- 076767-03-000
- SCREW
- 000G11-06-08U (2)
- AL EXTR
- 002726-51-018 (2)
- 002726-51-017 (2)
- SCREW
- 000G39-10-169 (18)
- SEALANT

FIRST USED	13 E30T	
TITLE:	DO NOT SCALE DRAWING	
	WATER SYSTEM INSTL	
SHEET 2	PART NO	182378
	REV	

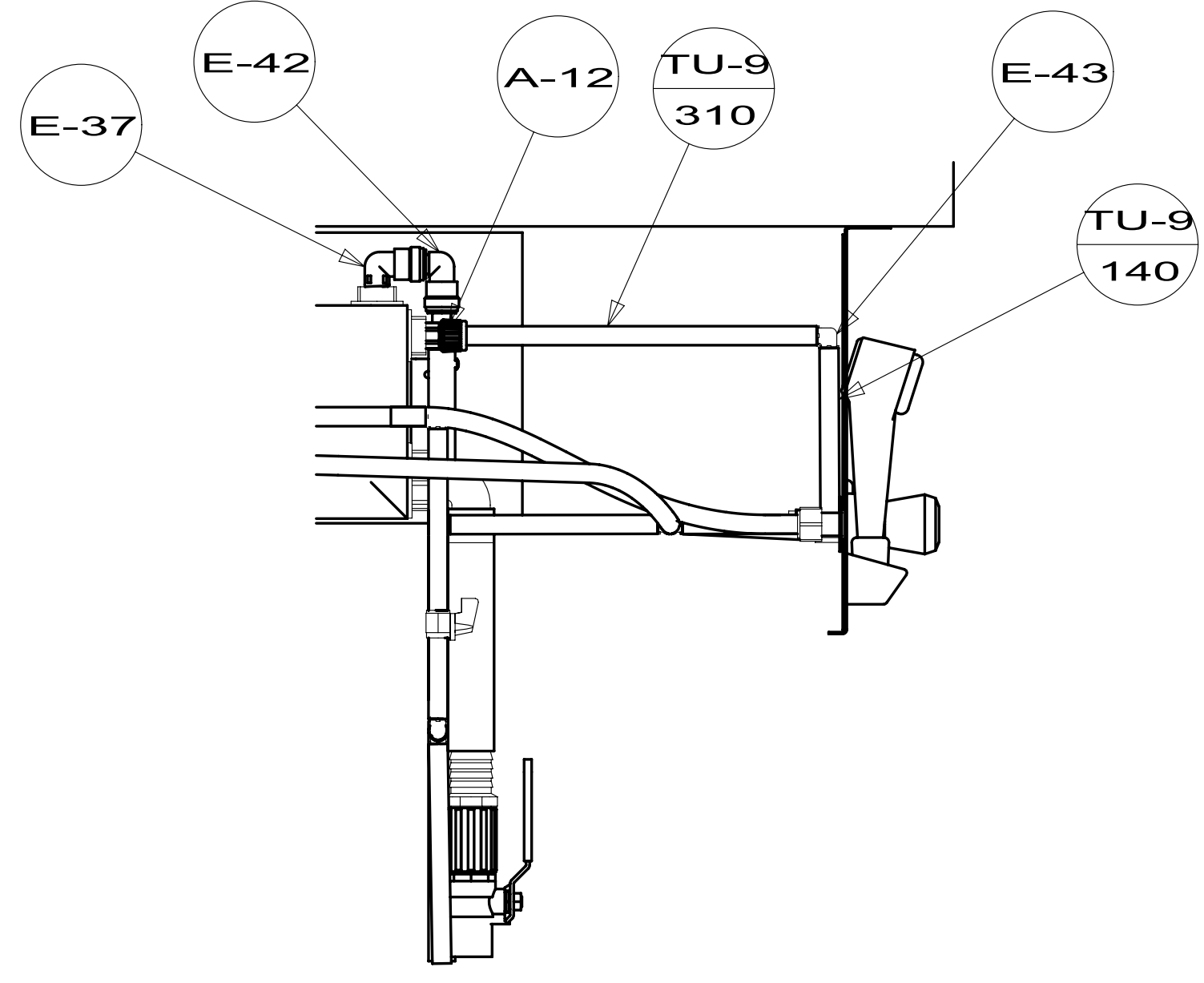

VIEW F

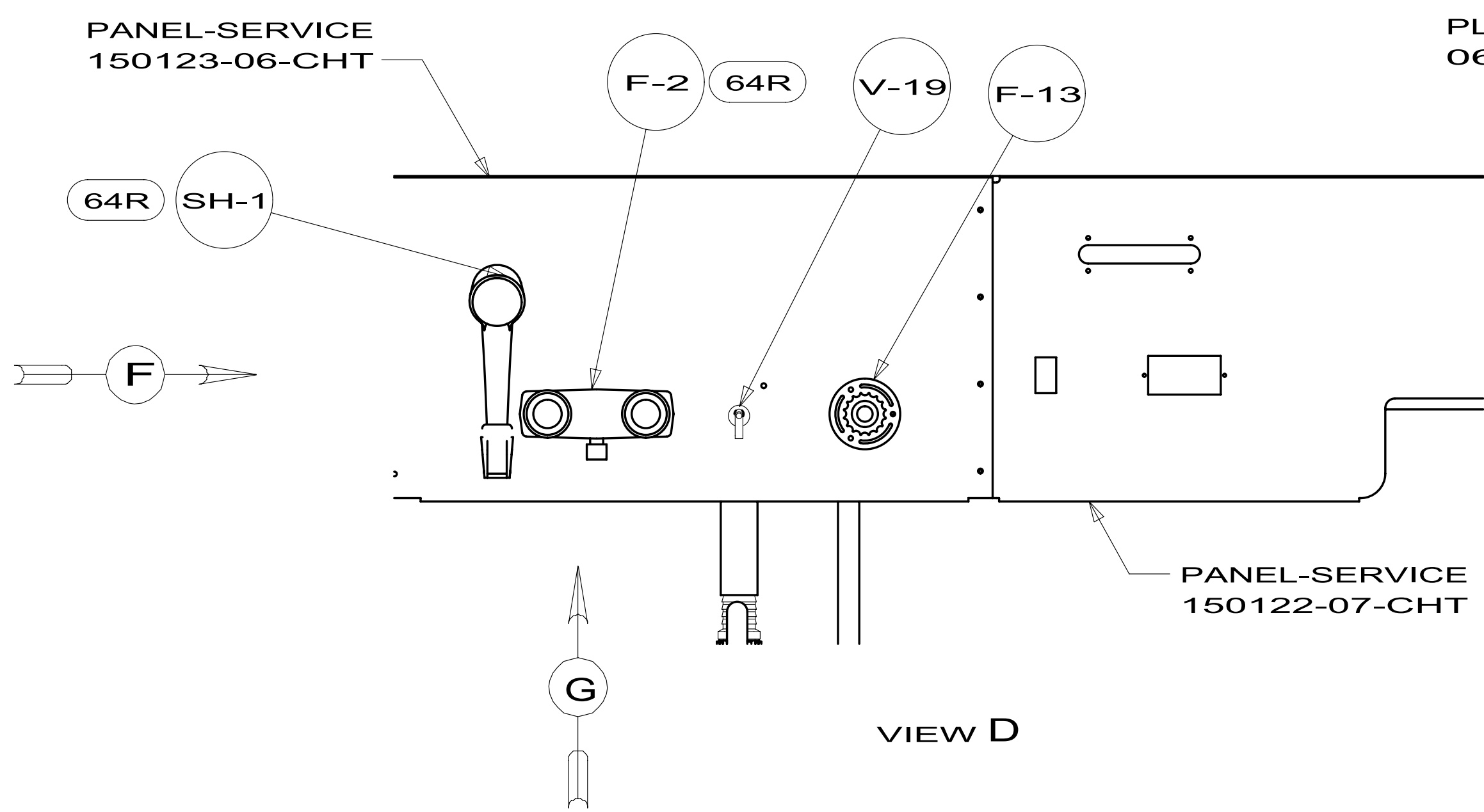

VIEW D

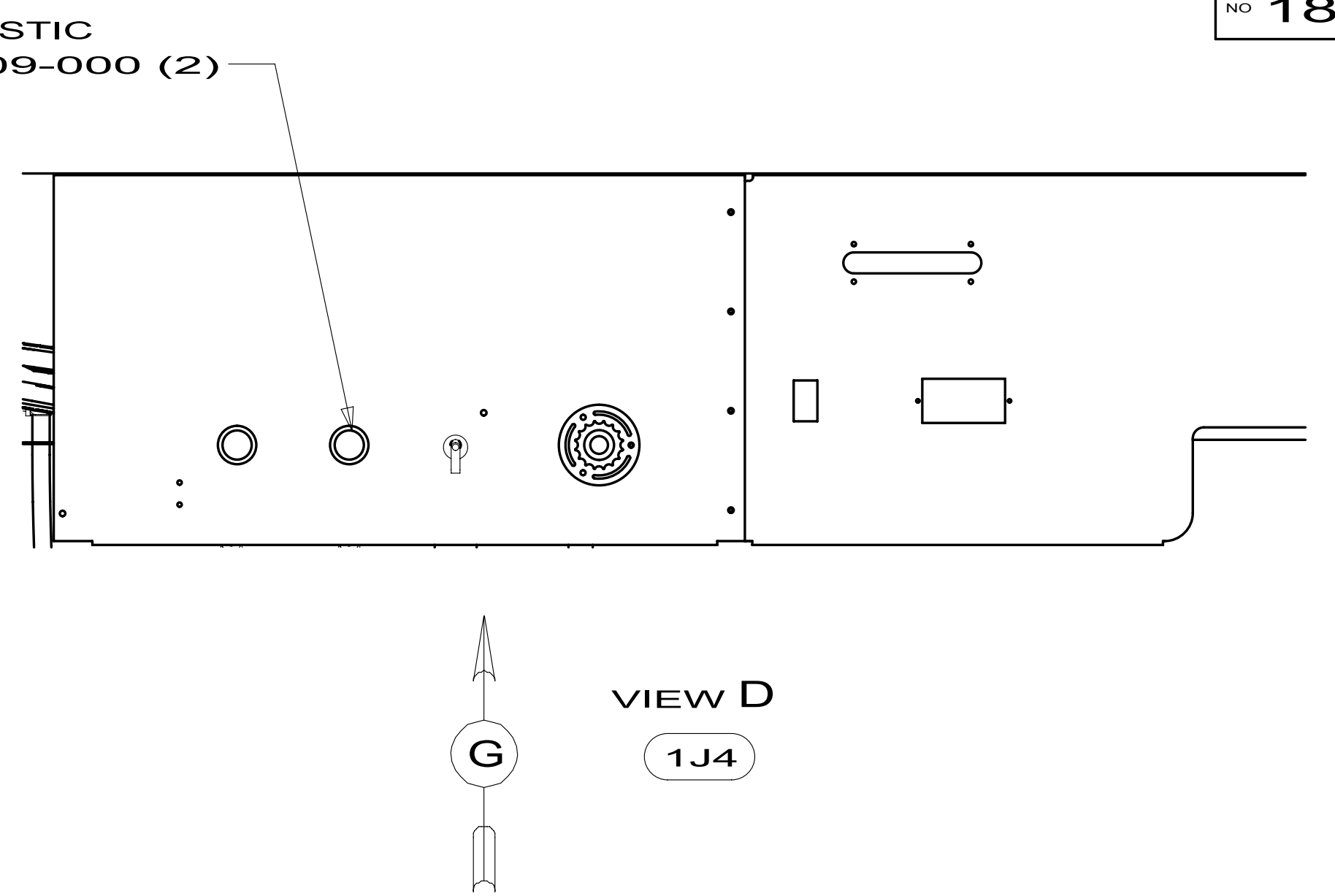

VIEW D
1J4

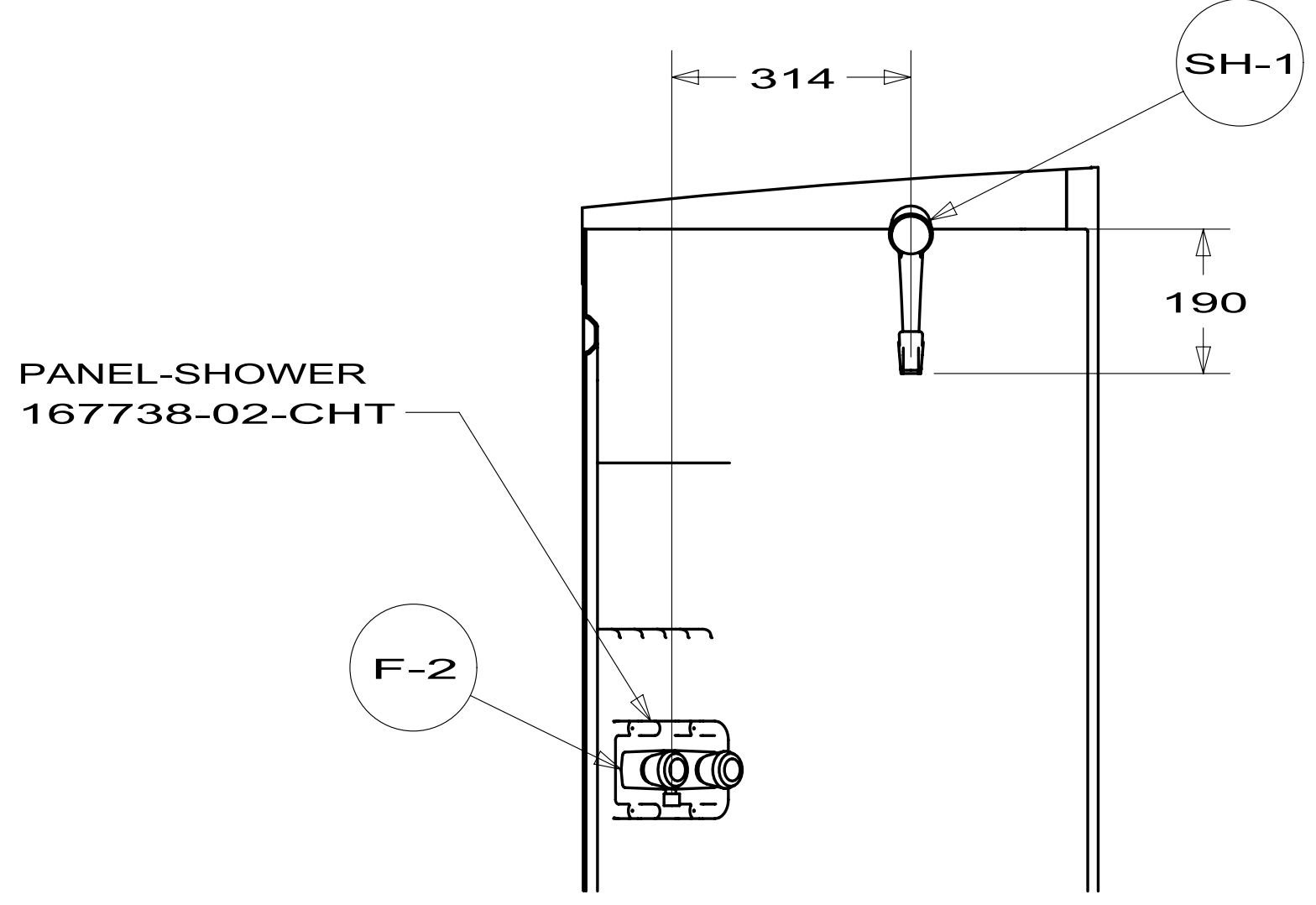

SECTION C-C
(ROTATED)

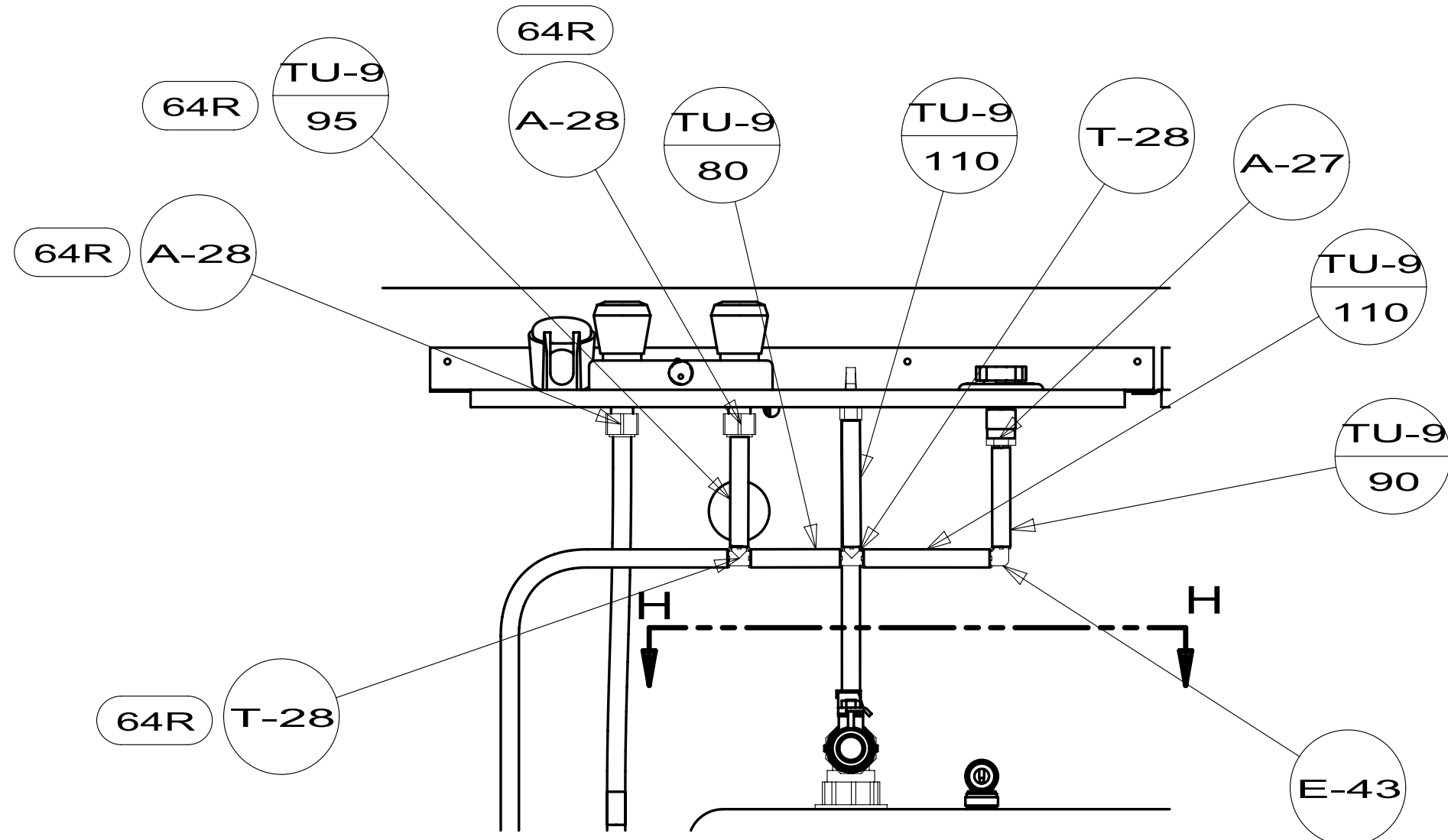

VIEW G

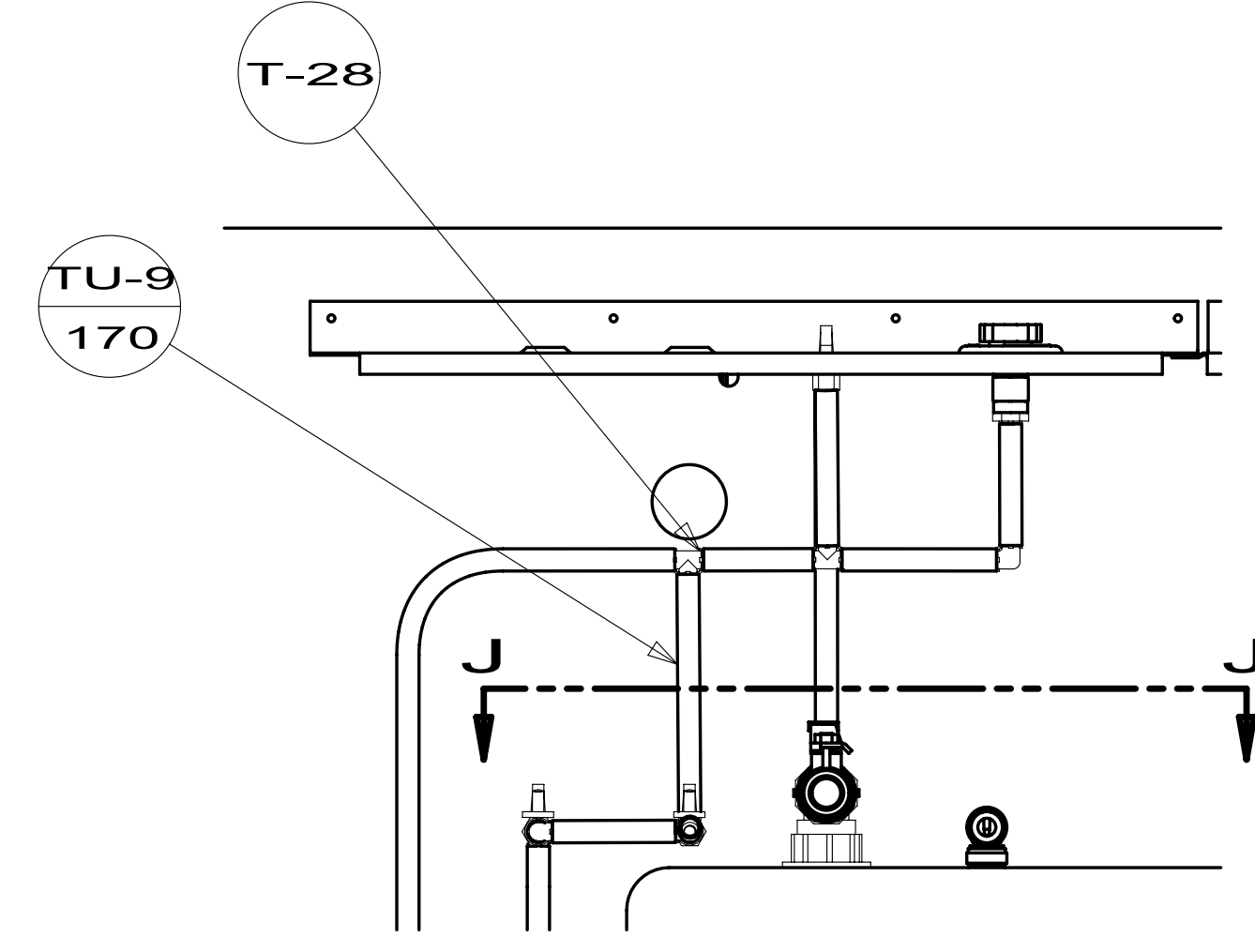

VIEW G
1J4

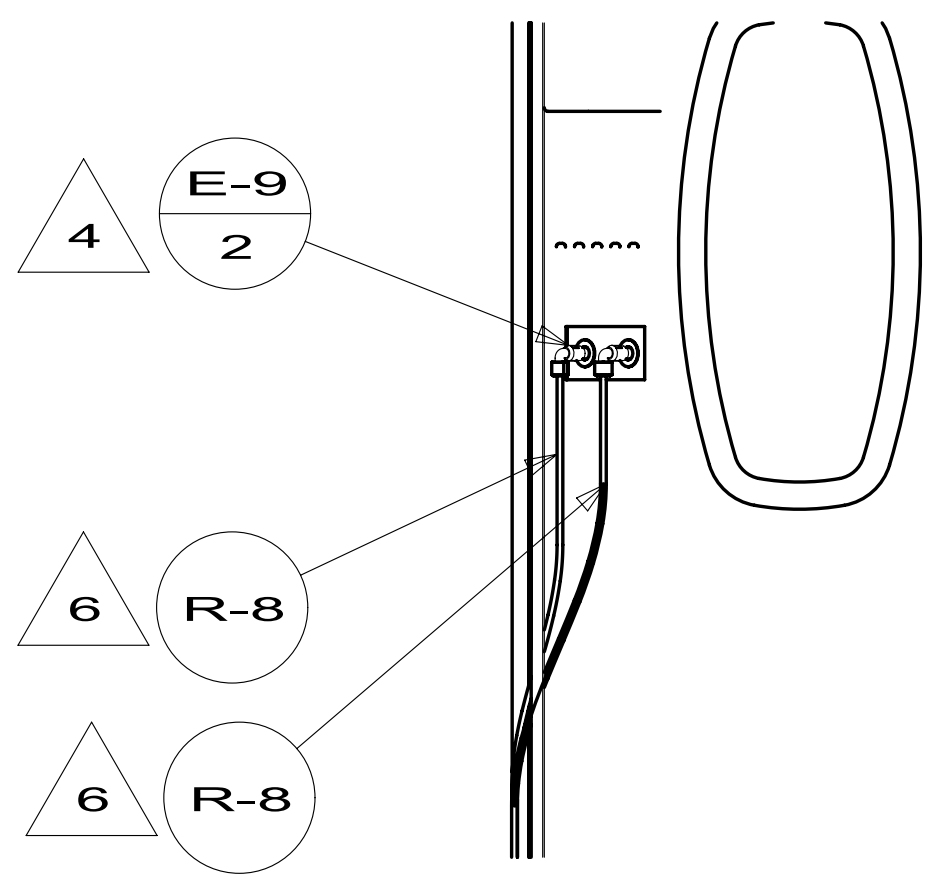

VIEW M
(ROTATED)

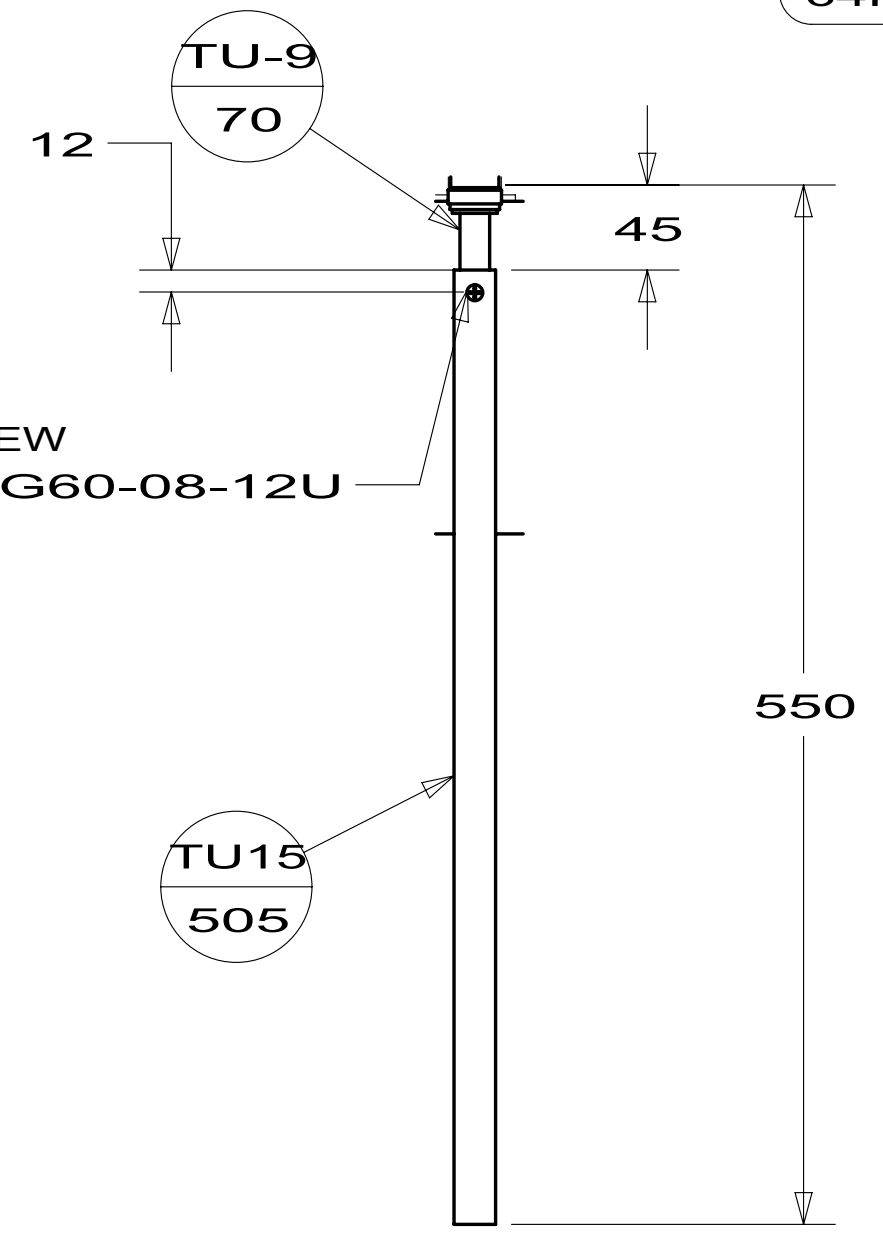

DETAIL R

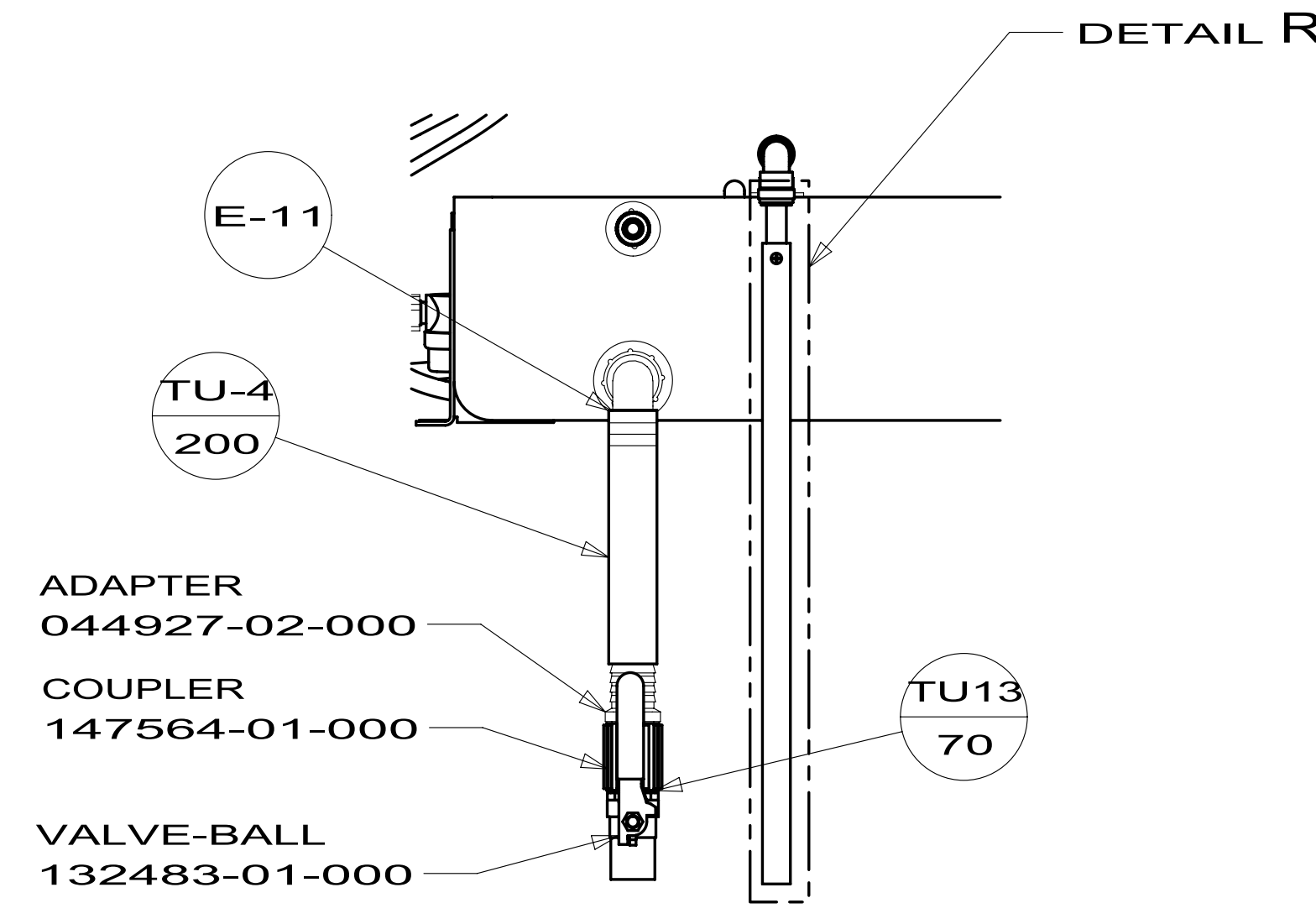

SECTION H-H

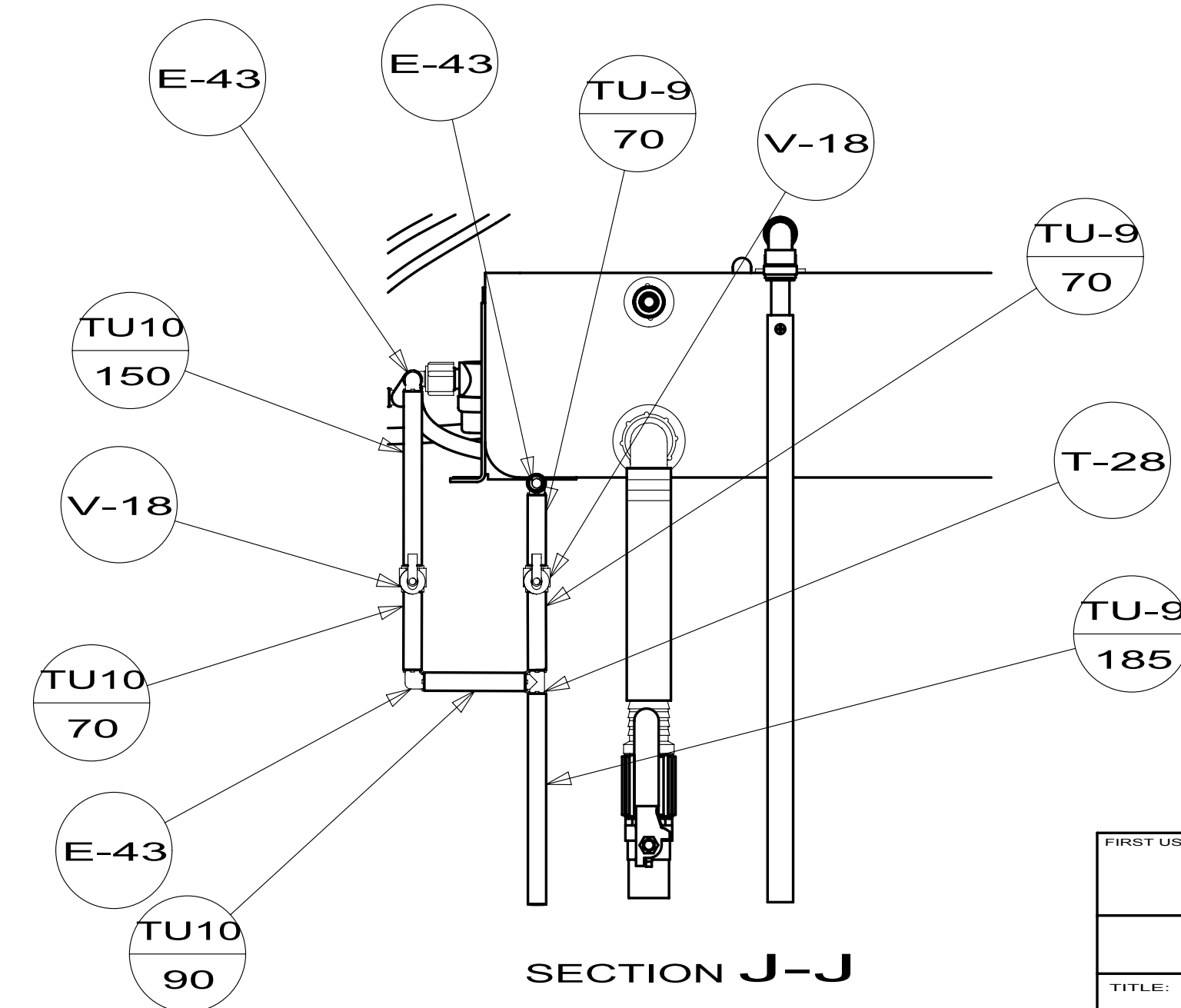

SECTION J-J
1J4

FIRST USED	13 E30T	
DO NOT SCALE DRAWING		
TITLE: WATER SYSTEM INSTL		
SHEET 3	PART NO 182378	REV

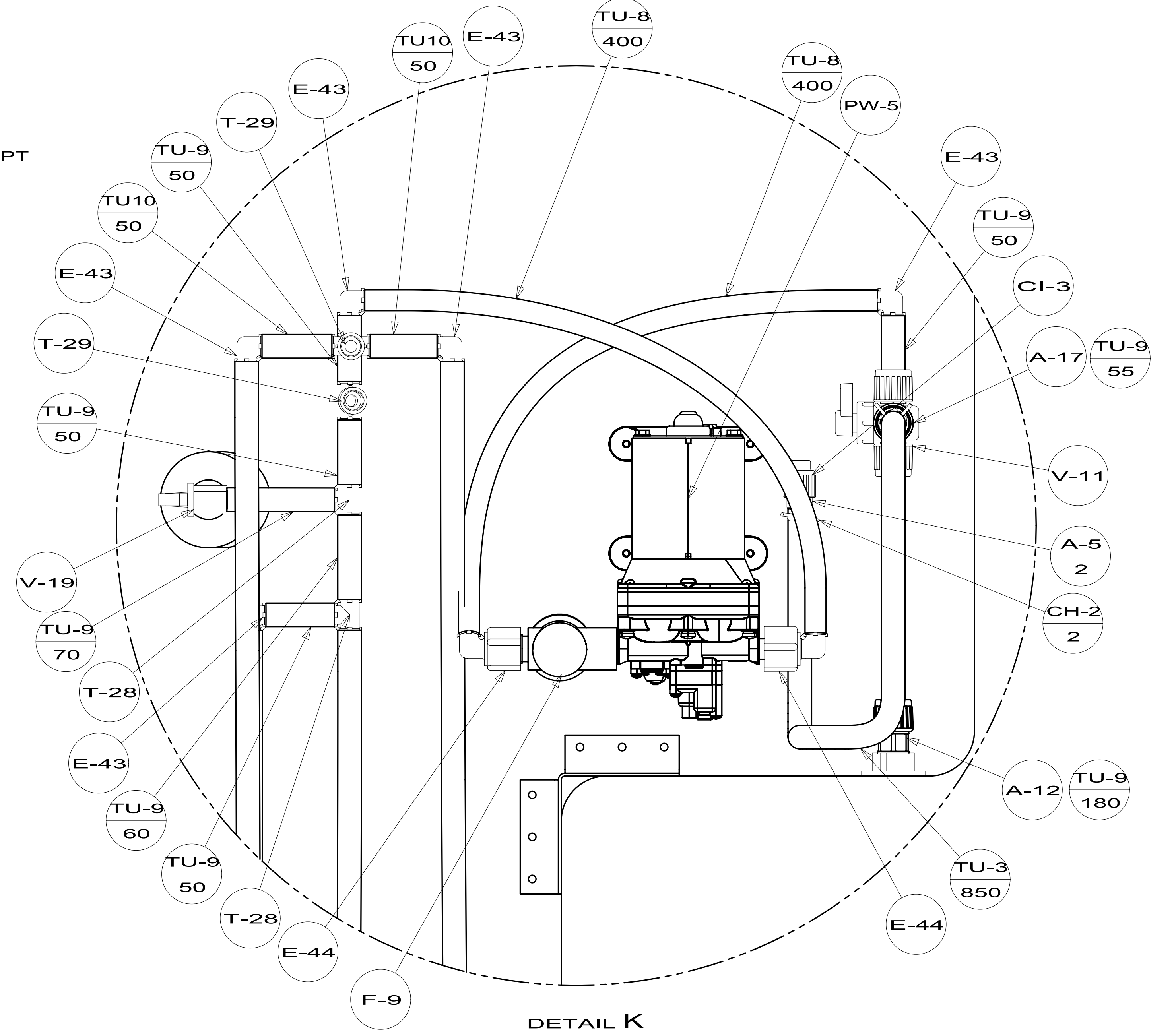
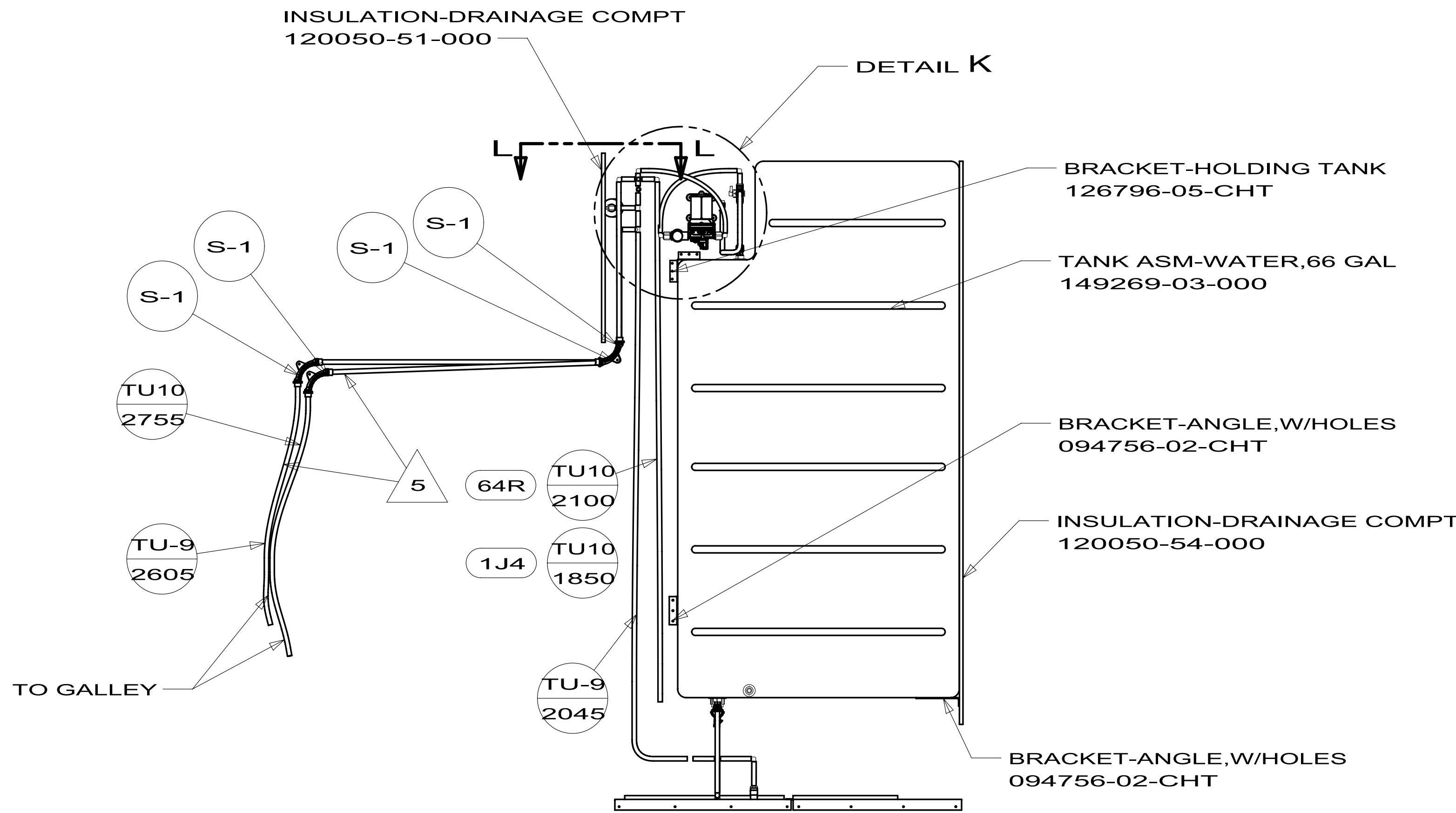

ONLY SHOWING LINES UNDER FLOOR

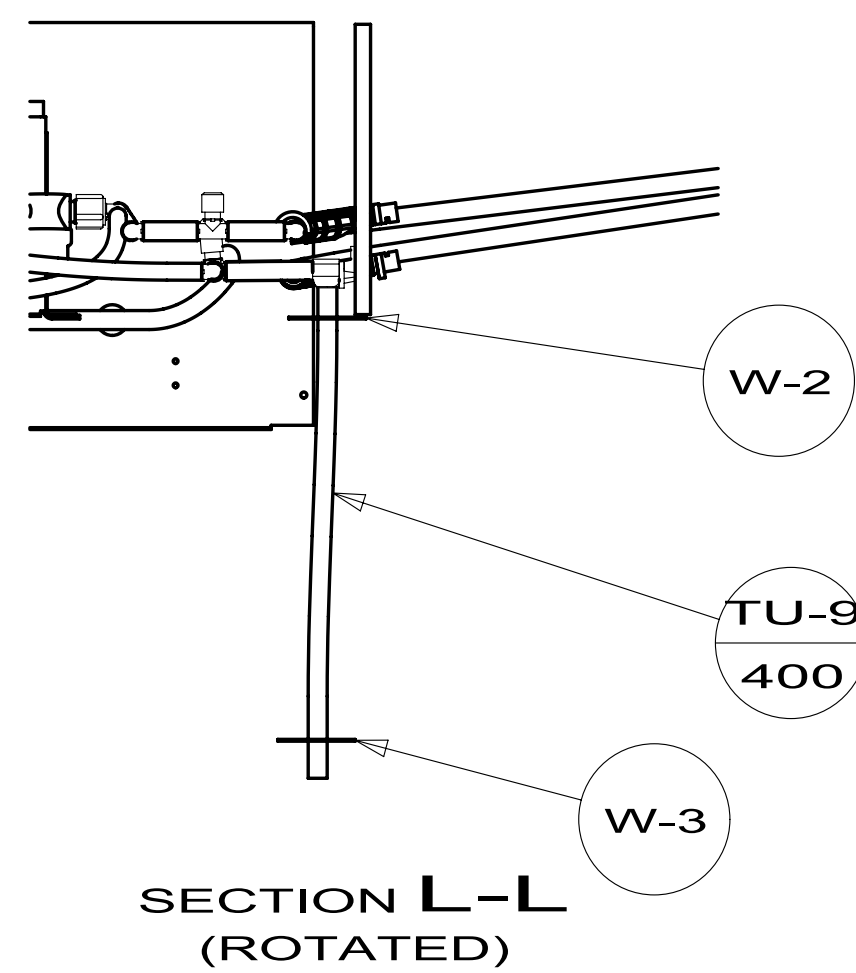

FIRST USED	13 E30T	
TITLE:	DO NOT SCALE DRAWING	
SHEET 4	PART NO	182378
		REV