

- 1B1 CODES/STANDARDS-USA
- 265 CODES/STANDARDS-CSA/CMVSS
- 43E TOILET-PORCELAIN
- 1JD DRAINAGE SYSTEM-HEATED-W/O
- 23T DRAINAGE SYSTEM-HEATED

9. PREPARE THE SURFACE PER MANUFACTURERS INSTRUCTIONS. BEFORE APPLYING THE HEAT PADS.
8. USE SMOOTH PLUMBERS PUTTY 167459-01-000 TO SEAL STRAINER (.2 PER STRAINER).
7. SECURE VENT PIPE TO FLOOR WITH CLAMP 062401-02-000 (3), SCREW 000G67-10-12U (3), BRACKET 136878-01-CHT (3).
6. VENT PIPE MUST PROJECT 51 MIN AND 64 MAX ABOVE ROOF FOR PROPER FIT AND FUNCTION. ADD S-1 (116666-01-CHT SEAL-VENT PIPE) AROUND PIPE ON ROOF BEFORE VENT CAP IS INSTALLED.
5. SEAL AROUND SHOWER WITH SILICONE.
4. SECURE DRAINAGE PIPES TO CABINET USING WIRE TIES 108046-02-000 AND SCREW 000G67-10-12U AT INTERVALS OF NOT MORE THAN 4 FEET APART.
3. ALL PIPE AND FITTINGS TO BE ASSEMBLED WITH SOLVENT 004020-01-000 (USA), 004020-02-000 (CAN)
2. SLOPE OF TRAP ARM MUST BE 6 PER 305 mm.
1. SLOPE OF HORIZONTAL PIPING TO BE MINIMUM OF 3 PER 305 mm.

NOTES:

FOR DRAINAGE CALLOUTS SEE DWG NO 116229-01-000

<b>WINNEBAGO</b>		COPYRIGHT 2013 WINNEBAGO INDUSTRIES, INC.	
DFTR	ORIG. DATE	ALL DIMENSIONS ARE IN MILLIMETERS	
CHKR			
P.E.			
M.E.	FIRST USED		
DSNR	13 524M		
UNSPECIFIED TOLERANCES ARE:		MATERIAL:	
WHOLE DIM (X)	: 3		
ONE-PLACE (X.X)	: 1.5		
TWO-PLACE (X.XX)	: 0.50		
ANGLE	: 1°		
THIRD ANGLE PROJECTION			
DO NOT SCALE DRAWING		REFER TO ES0018 FOR FASTENER TIGHTENING GUIDELINES	
TITLE: DRAINAGE SYSTEM INSTL			
SHEET 1 OF 4	PART NO	180954	REV
REF:	1	05-Sep-2013	

\* 180954 \* A

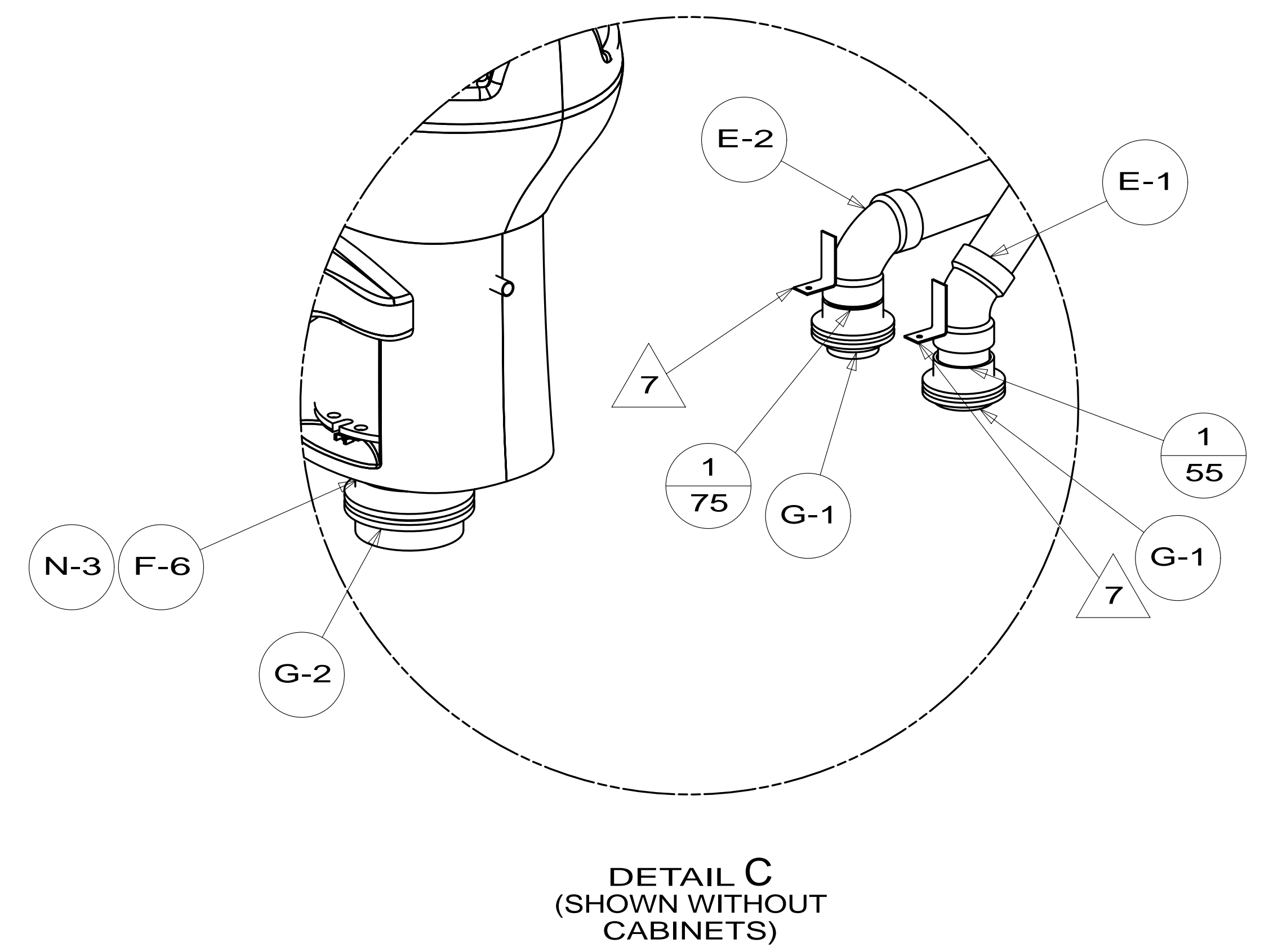
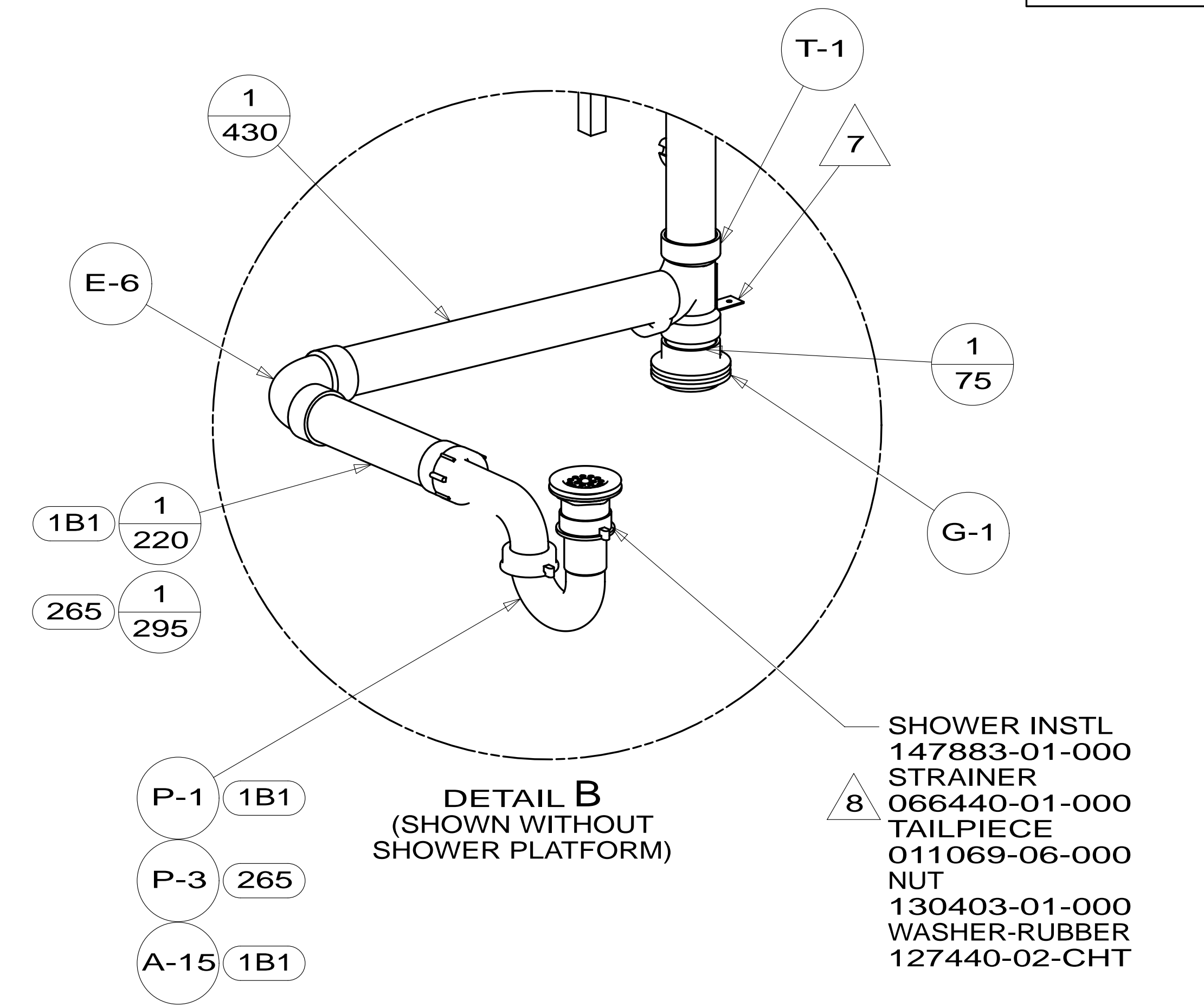
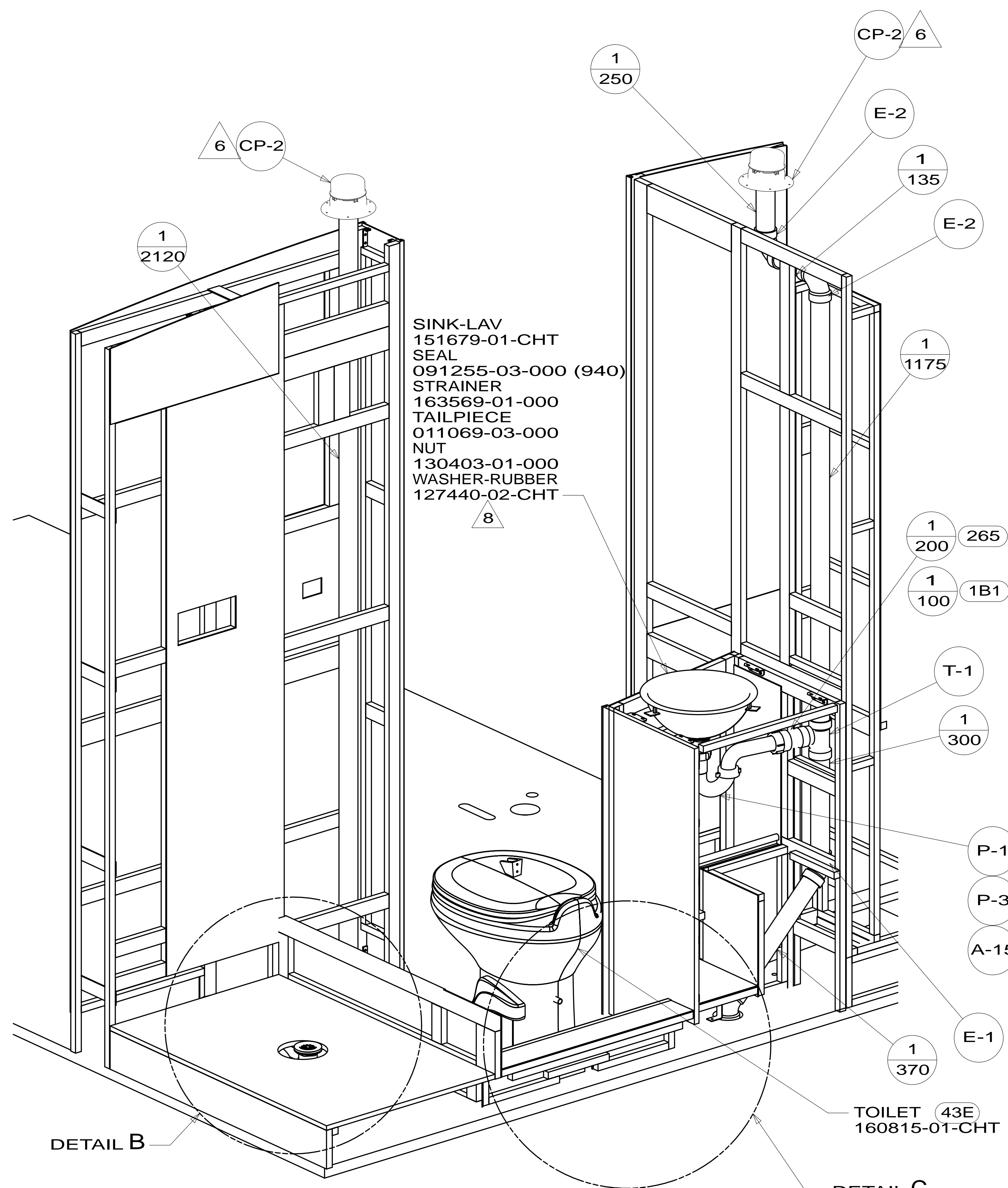

FIRST USED	13 524M
DO NOT SCALE DRAWING	
TITLE: DRAINAGE SYSTEM INSTL	
SHEET 2	PART NO 180954 REV
05-Sep-2013	

\* 180954 \* A

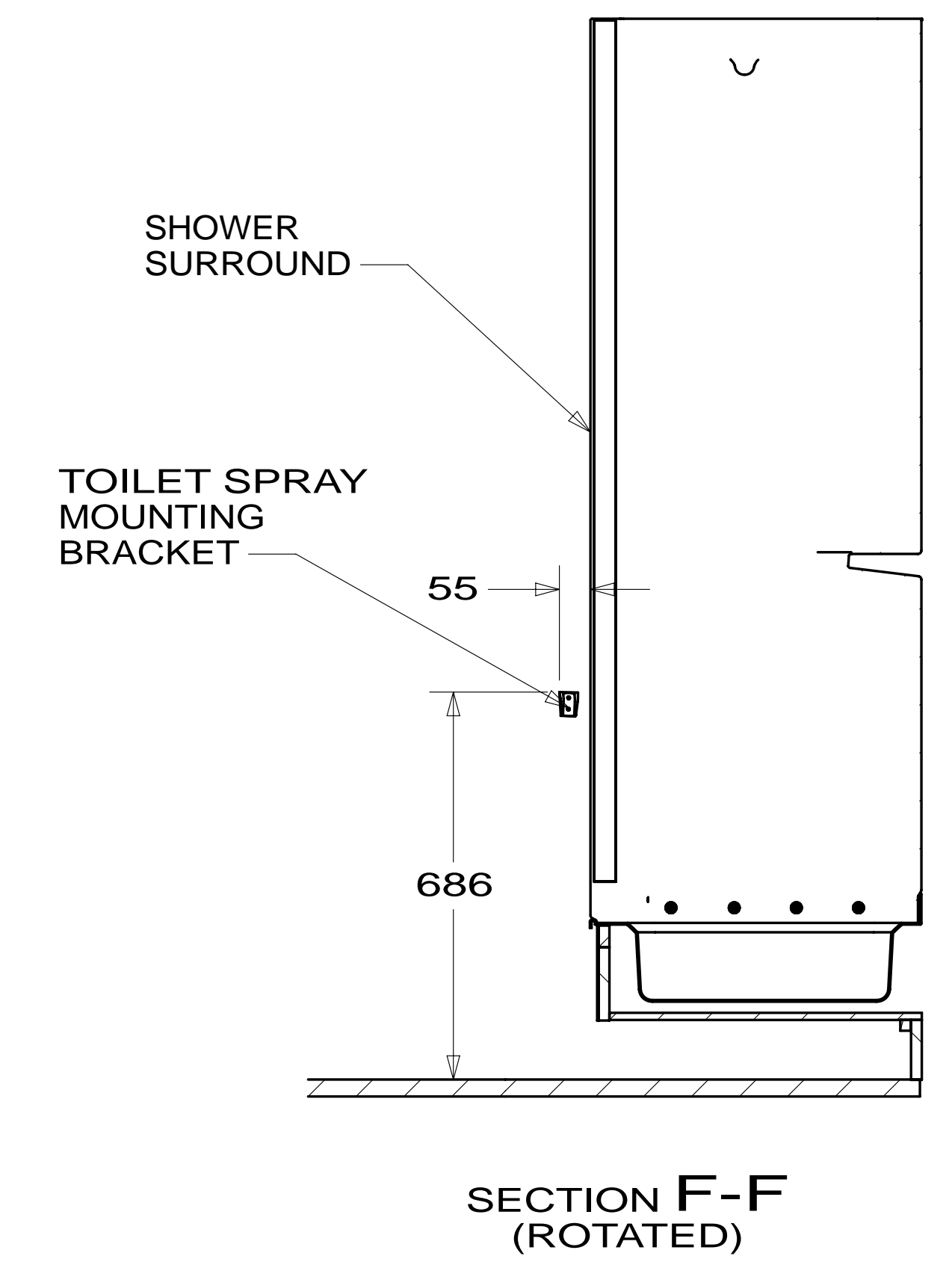
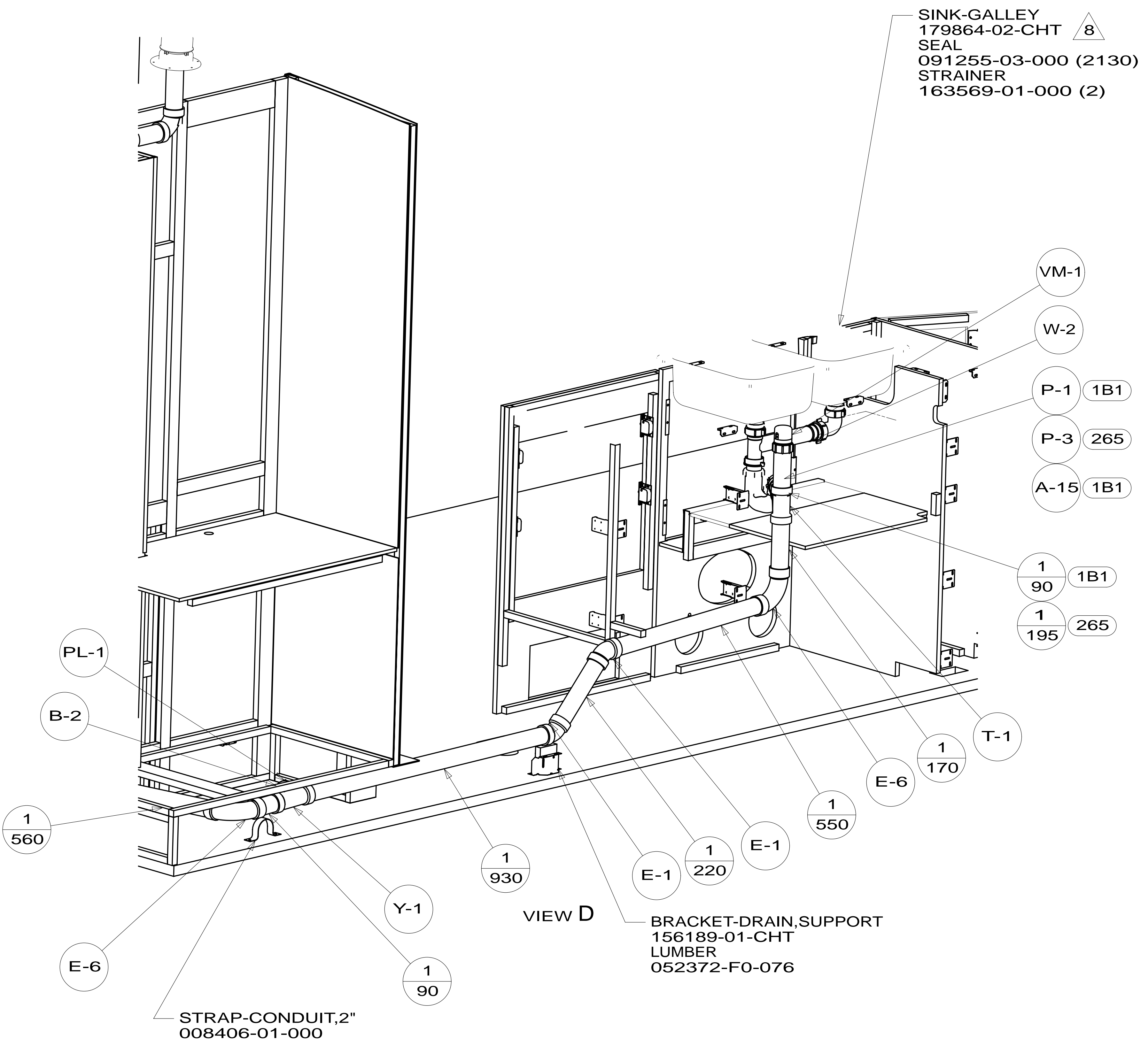

FIRST USED	13 524M	
DO NOT SCALE DRAWING		
TITLE: DRAINAGE SYSTEM INSTL		
SHEET 3	PART NO 180954	REV
		05-Sep-2013

\*180954 \*A

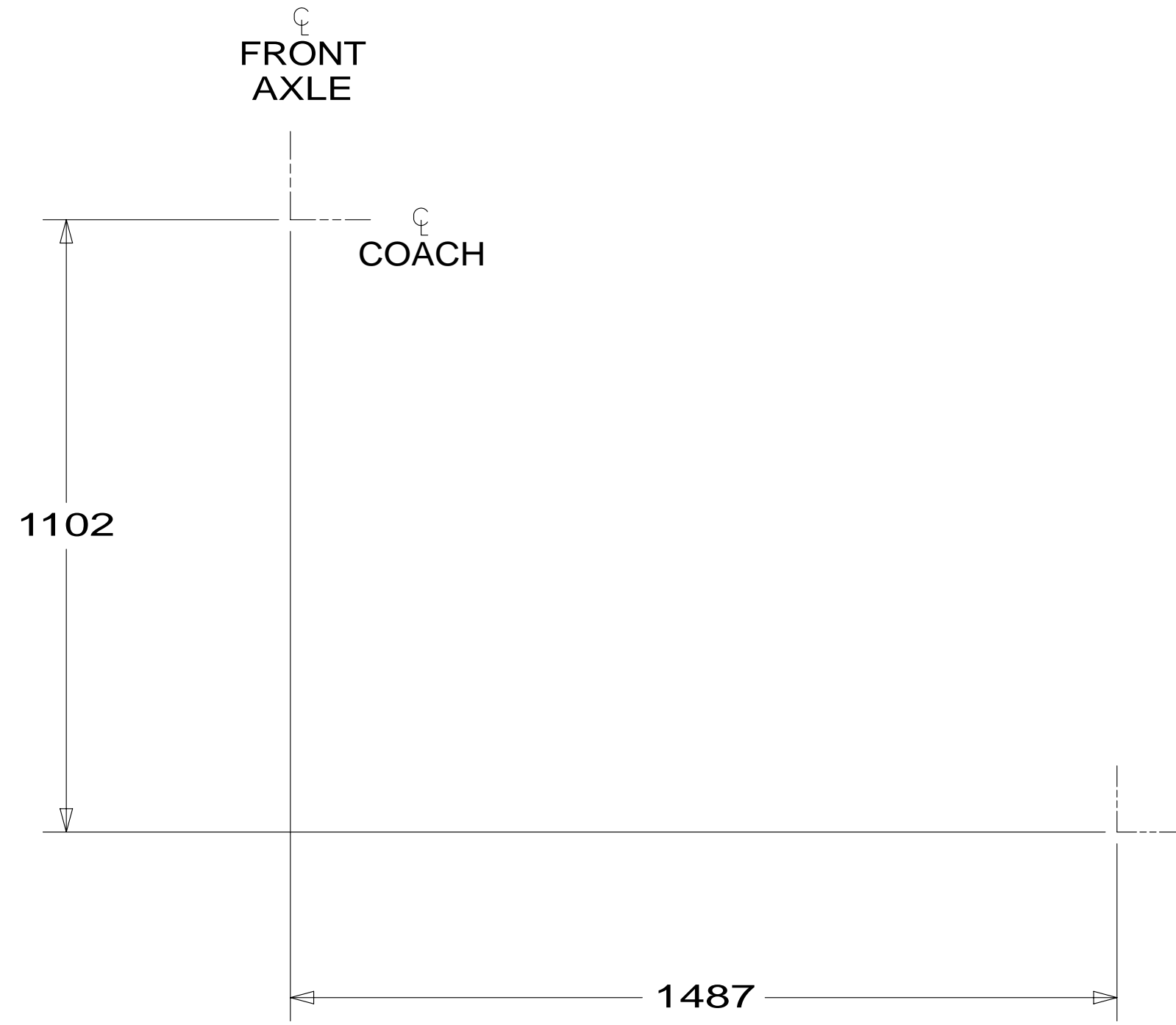

VIEW SHOWING TANKS AND DRAINS

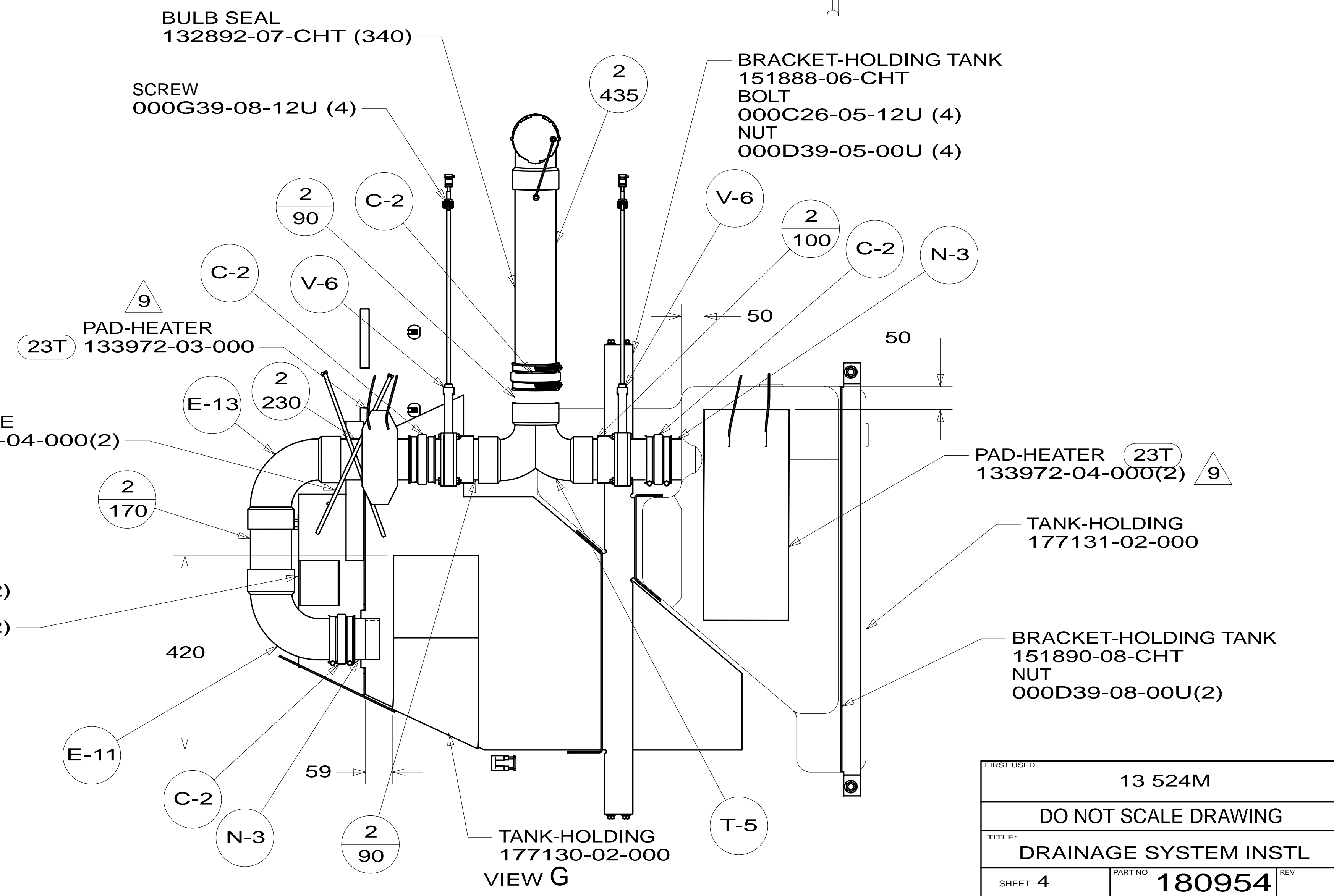
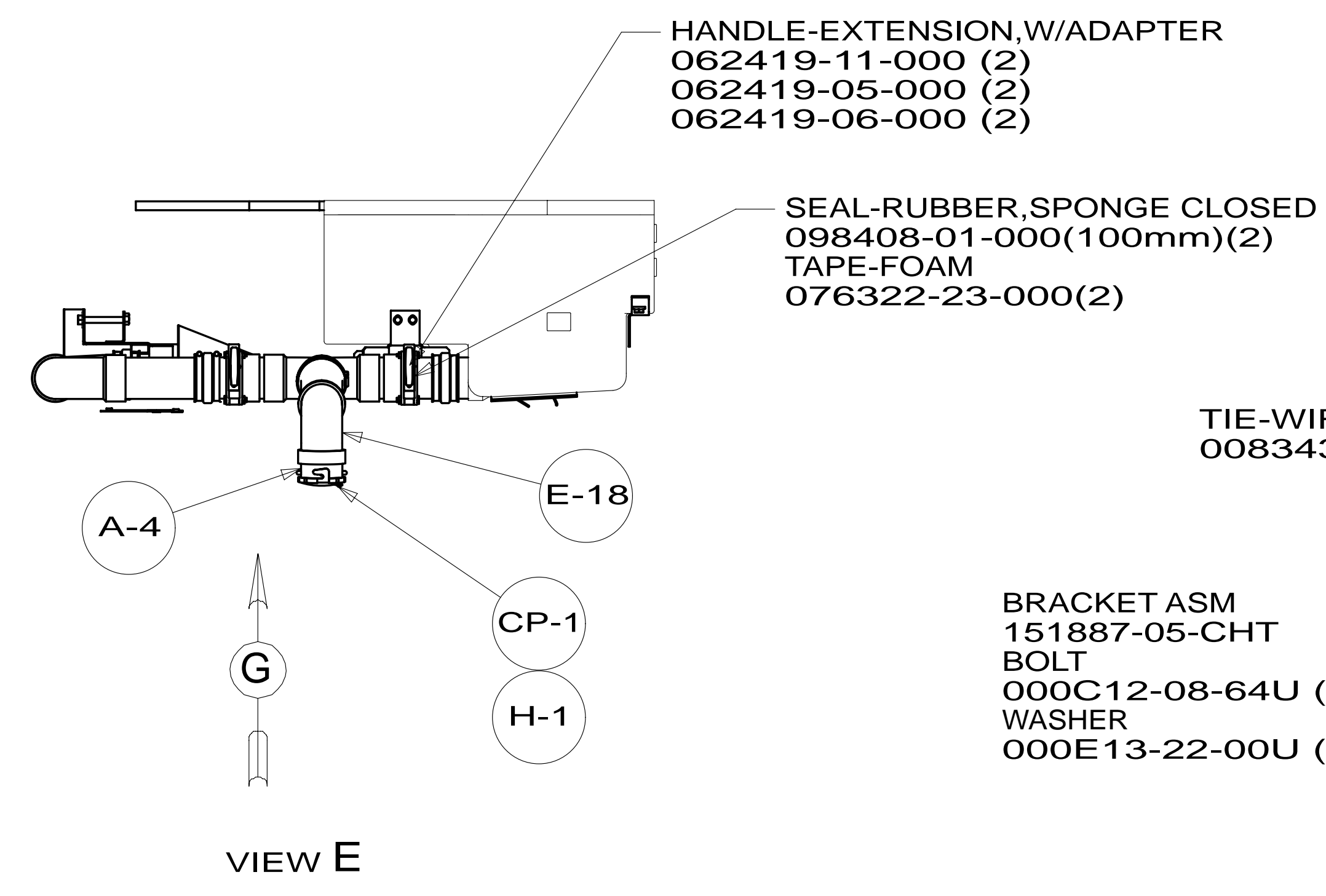
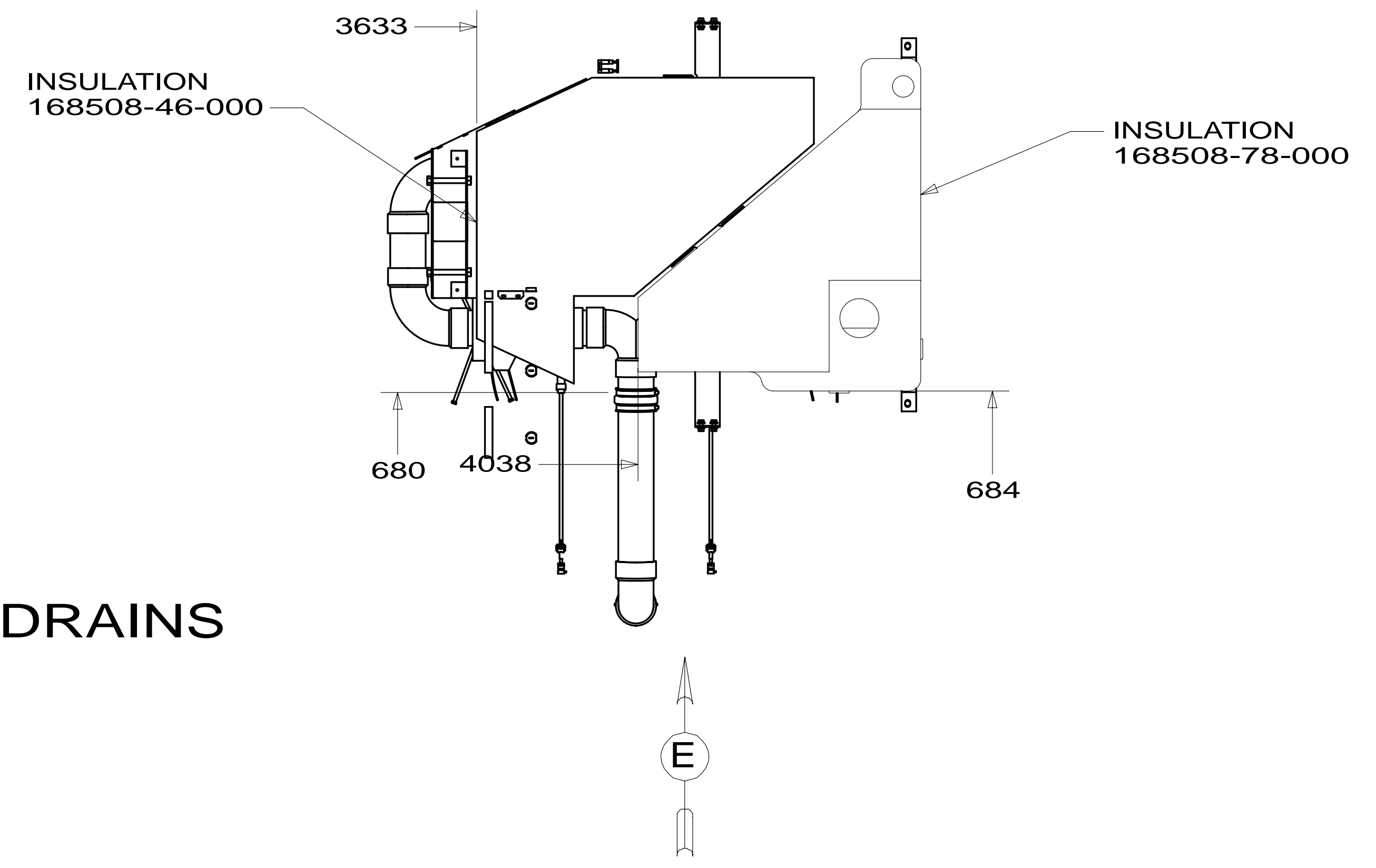

FIRST USED	13 524M	
DO NOT SCALE DRAWING		
TITLE: DRAINAGE SYSTEM INSTL		
SHEET 4	PART NO 180954	REV
		1 05-Sep-2013

\* 180954 \* A

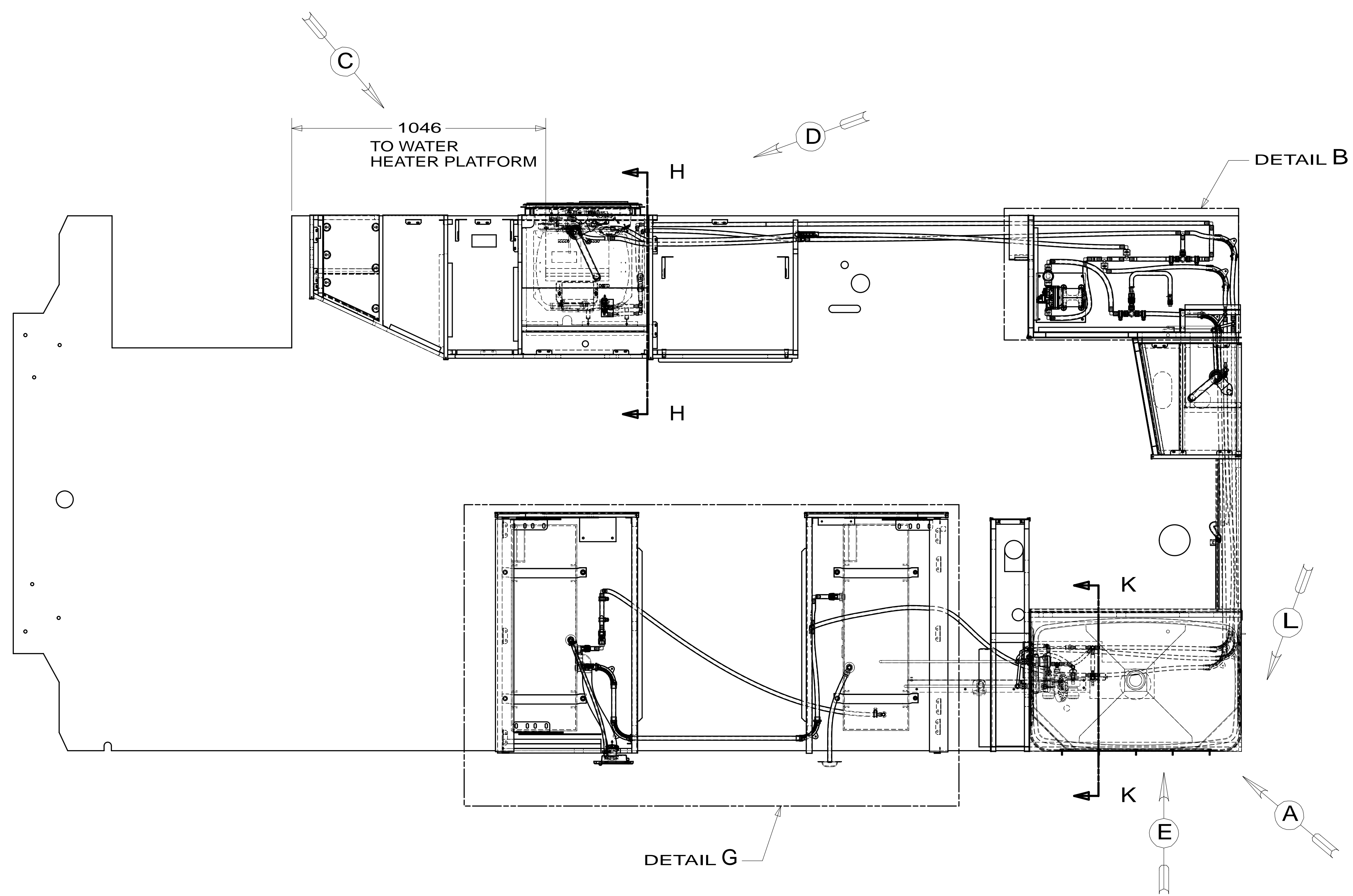

- 29B WATER PURIFIER
- 501 WATER PURIFIER WITHOUT
- 53E WATER SYS WINTERIZATION PKG
- 53B WTR HTR-6GAL ELECTRIC/LP GAS
- 64R EXTERIOR WASH STATION

- 9 LAVATORY FAUCET SPOUT TO BE TURNED 180° SO CONTROLS ARE ON LEFT SIDE.
- 8. ALL CRIMP FITTINGS TO 1/2" PEX TUBING REQUIRE 1/2" CLAMP 140171-03-000.
- 7. ALL CRIMP FITTINGS TO 5/8" PEX TUBING REQUIRE 5/8" CLAMP 140171-04-000.
- 6 ADD TEFLON TAPE 010405-03-000.
- 5 ADD TEFLON TAPE 010405-02-000.
- 4 ADD TEFLON TAPE 010405-01-000.
- 3. ALL TUBING TO BE SECURED AT 1200 INTERVALS MAXIMUM WITH CLAMP 010495-01-000 AND SCREW 000G67-10-12U OR EQUIVALENT.
- 2. TUBING TO BE INSTALLED WITH SUFFICIENT SLOPE TO PROVIDE DRAINAGE TO NEAREST VALVE.
- 1. PLASTIC FITTINGS TO BE SEALED WITH SEALANT 084456-01-000.

- 13 INSTALL BETWEEN MOUNTING PLATE AND RETAINING NUTS.
- 12 INSTALL CONNECTOR WITH TAPERED END AWAY FROM FAUCET.
- 11 VENT TUBE MUST BE PROJECTED 6 TO 15MM FROM SIDEWALL FOR PROPER FIT AND FUNCTION. SEAL TUBE IN PLACE.
- 10 TURN FAUCET APPROXIMATELY 15° SO THAT THE HANDLE MISSES THE WINDOW TREATMENTS.

FOR WATER CALLOUTS SEE DWG NO 116230-01-000

		COPYRIGHT 2013 WINNEBAGO INDUSTRIES, INC.	
DFT-ORIG	ORIG. DATE	ALL DIMENSIONS ARE IN MILLIMETERS	
CHKR			
P.E.			
M.E.	FIRST USED		
DSNR		13 524M	
UNSPECIFIED TOLERANCES ARE:		MATERIAL:	
WHOLE DIM (X)	: 3		
ONE-PLACE (X.X)	: 1.5		
TWO-PLACE (X.XX)	: 0.50		
ANGLE	: 1°		
THIRD ANGLE PROJECTION			
DO NOT SCALE DRAWING		REFER TO ES0018 FOR FASTENER TIGHTENING GUIDELINES	
TITLE: WATER SYSTEM INSTL			
SHEET 1 OF 5	PART NO	180925	REV
REF:	1	05-Sep-2013	

NOTES:

\* 180925 \* A

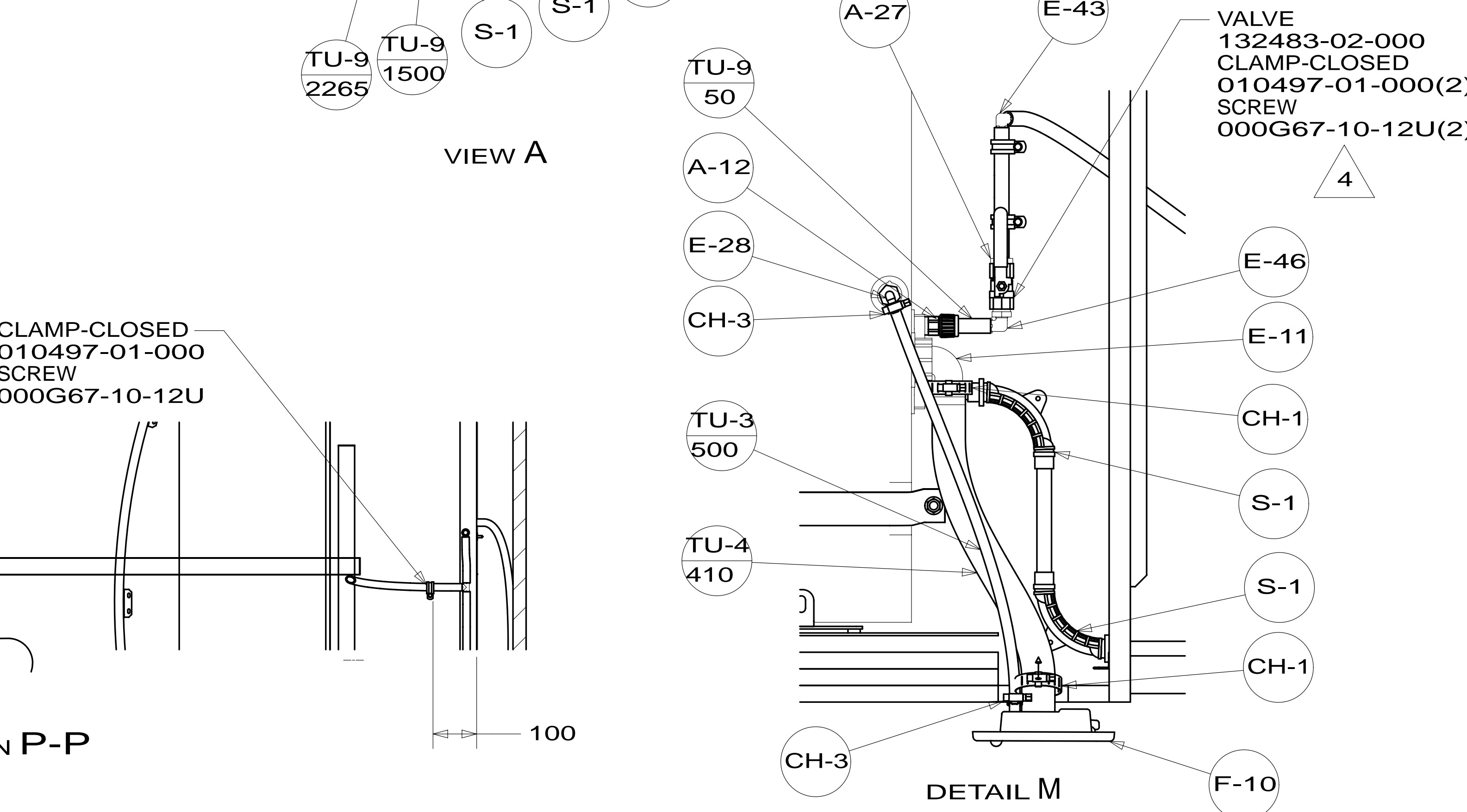
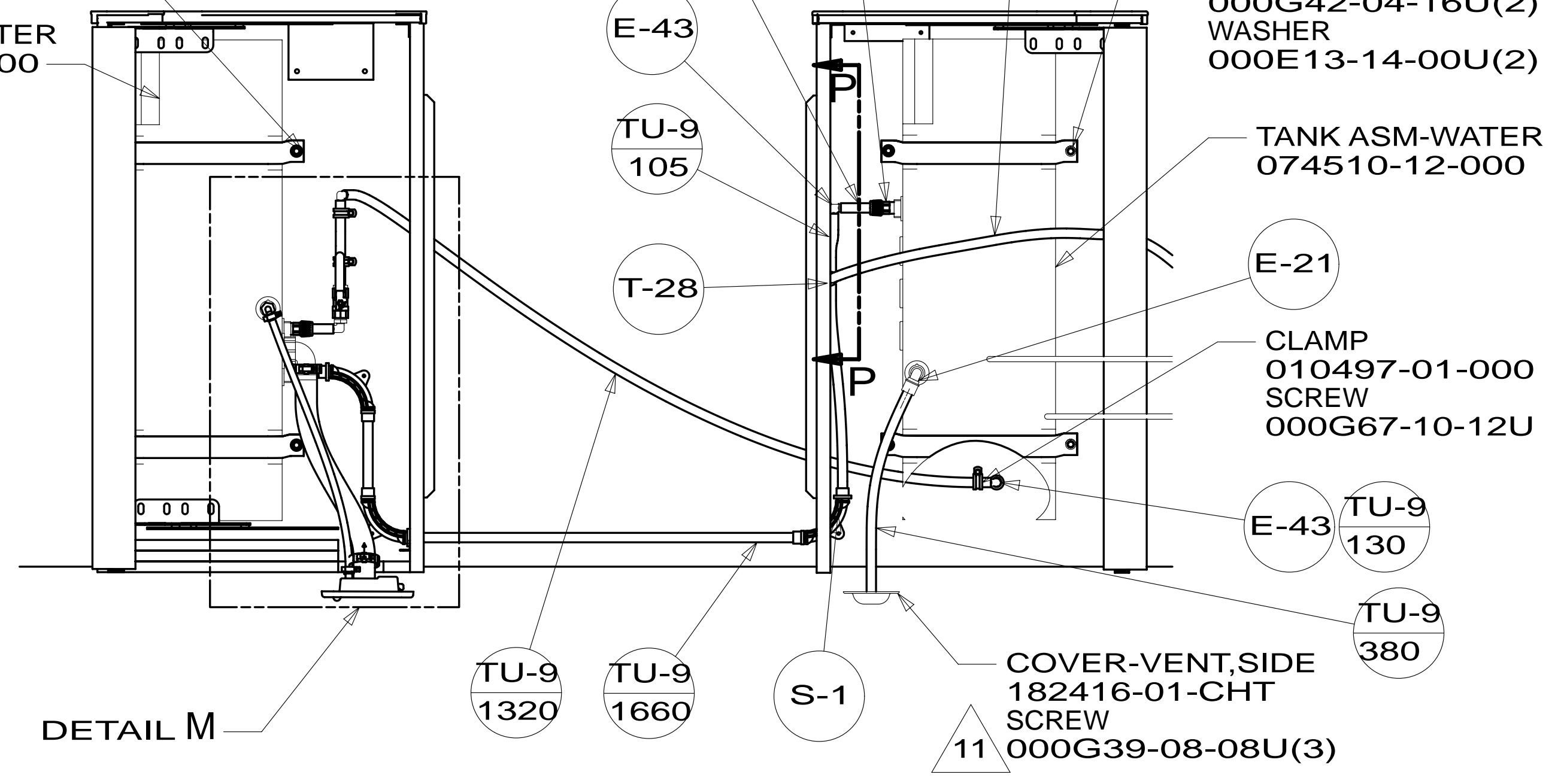
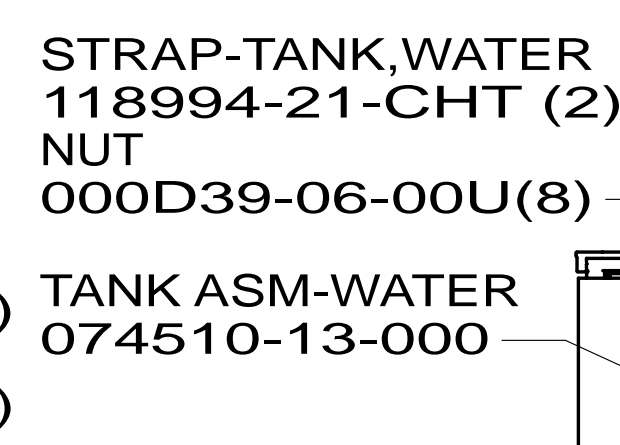
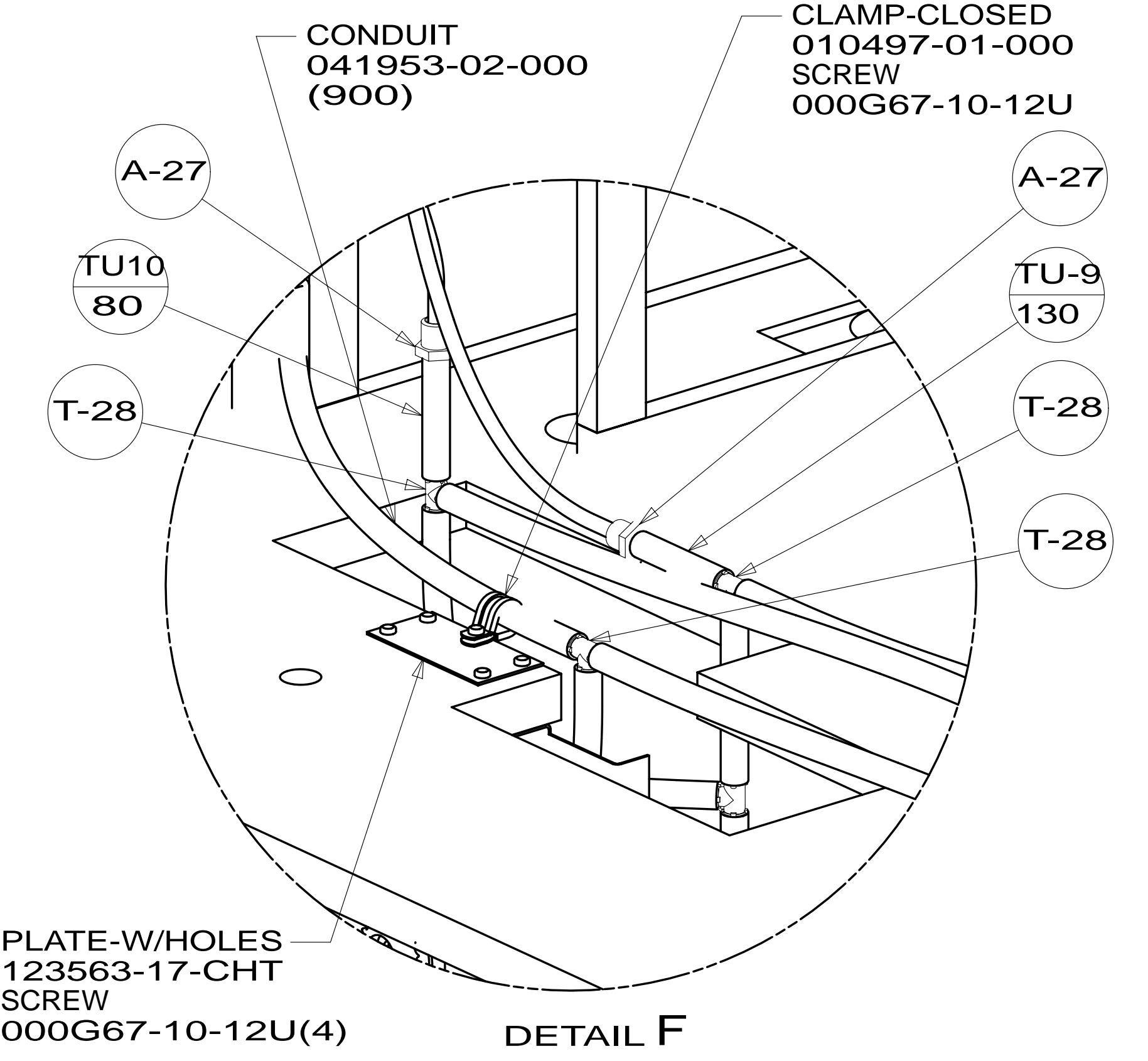
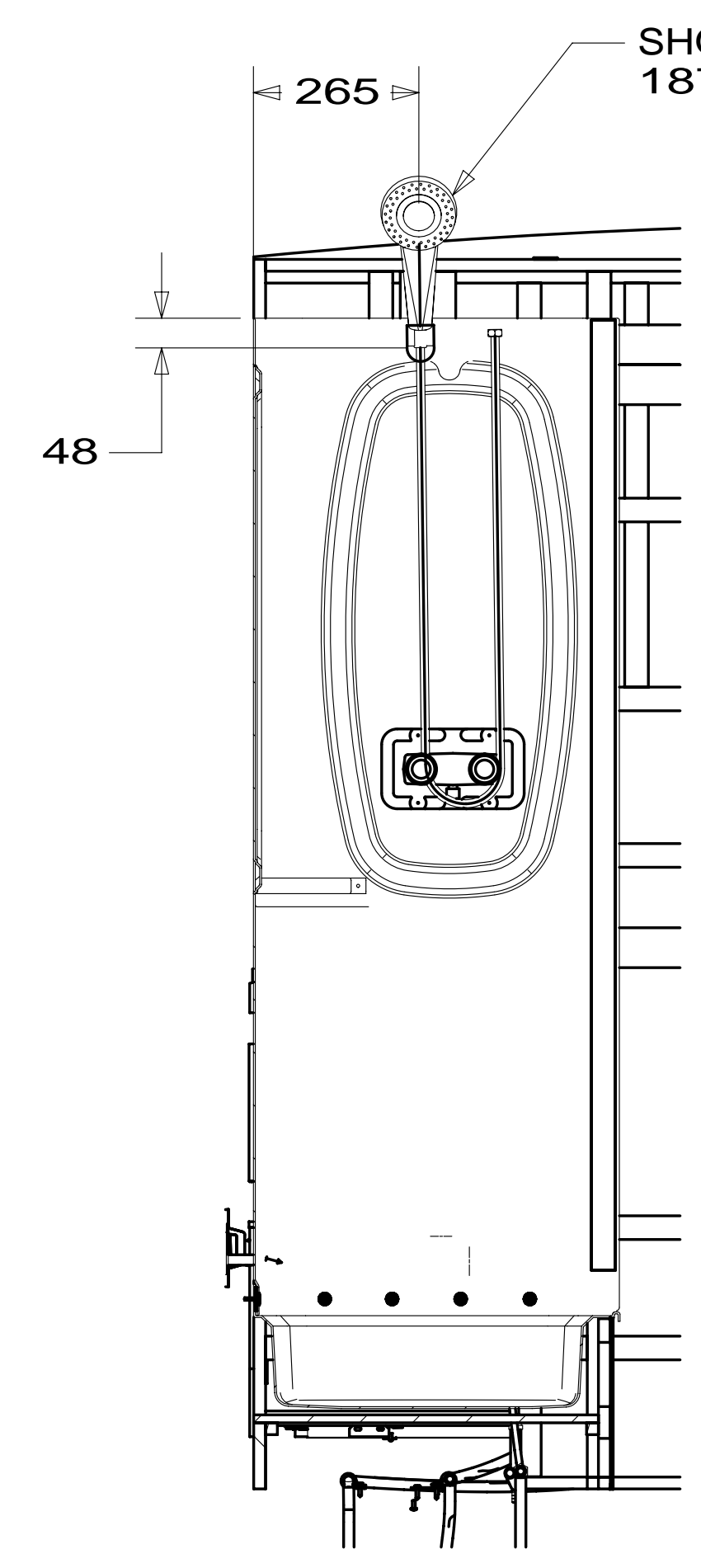
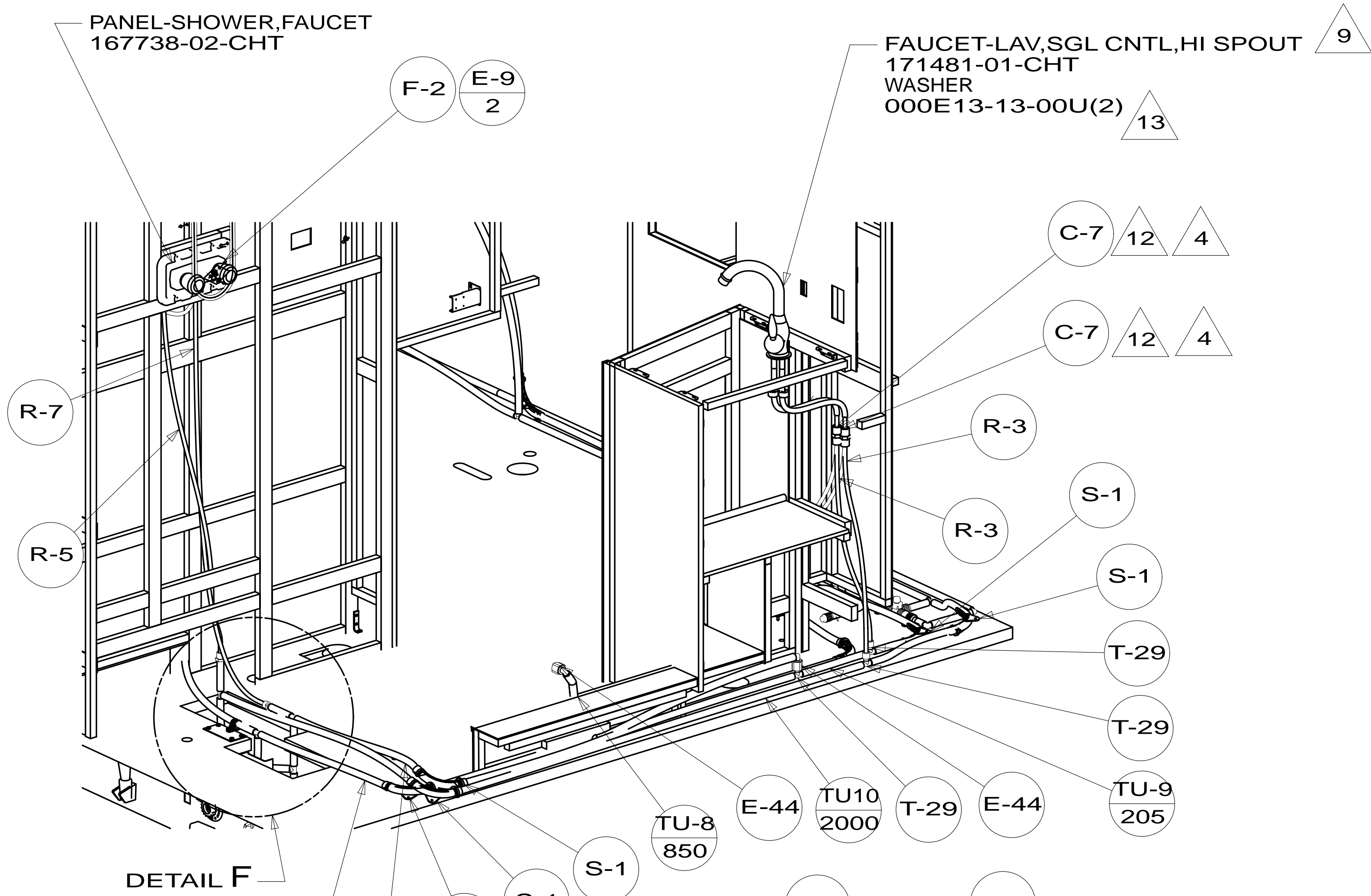

FIRST USED	13 524M
DO NOT SCALE DRAWING	
TITLE: WATER SYSTEM INSTL	
SHEET 2	PART NO 180925 REV
05-Sep-2013	

\* 180925

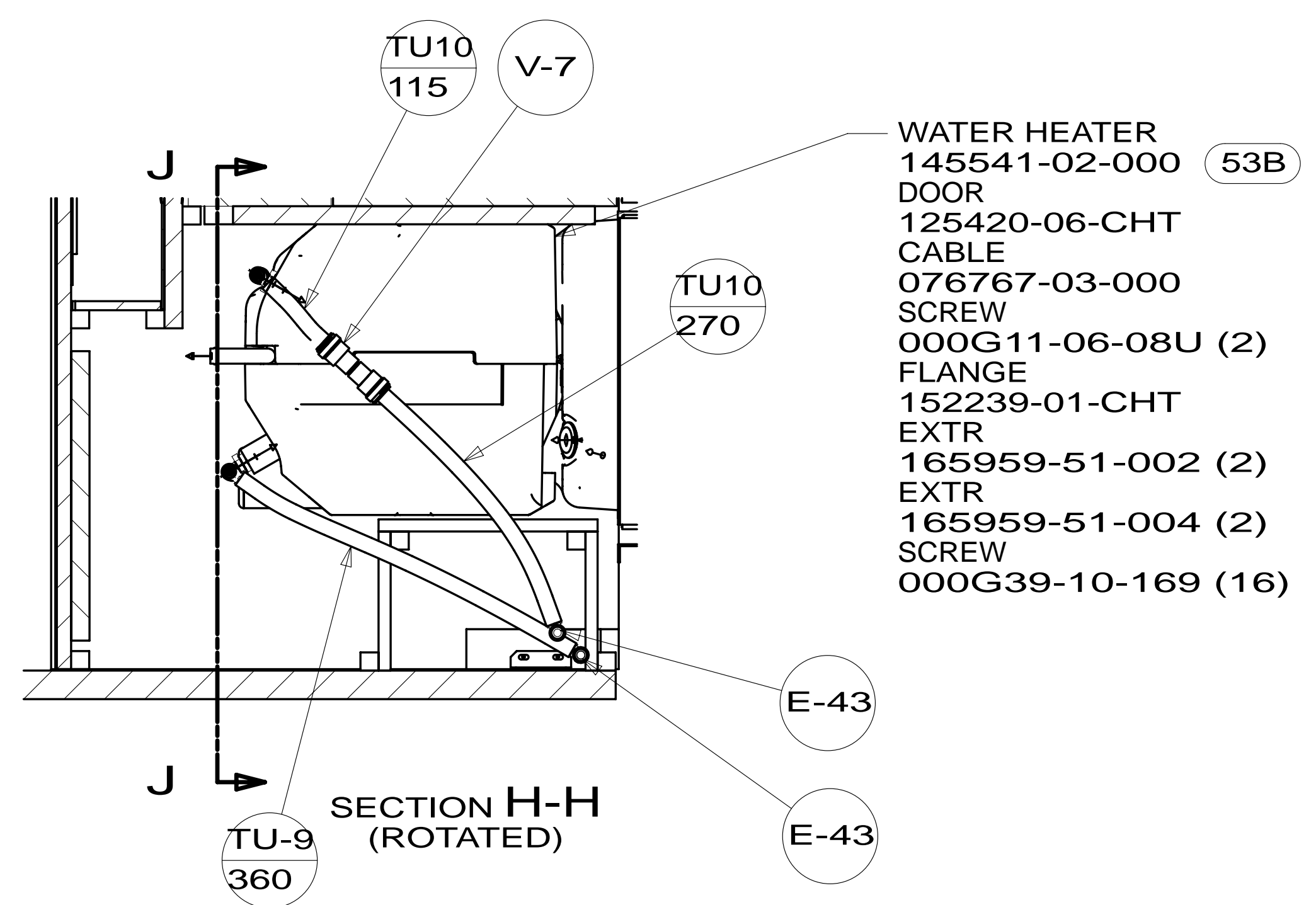
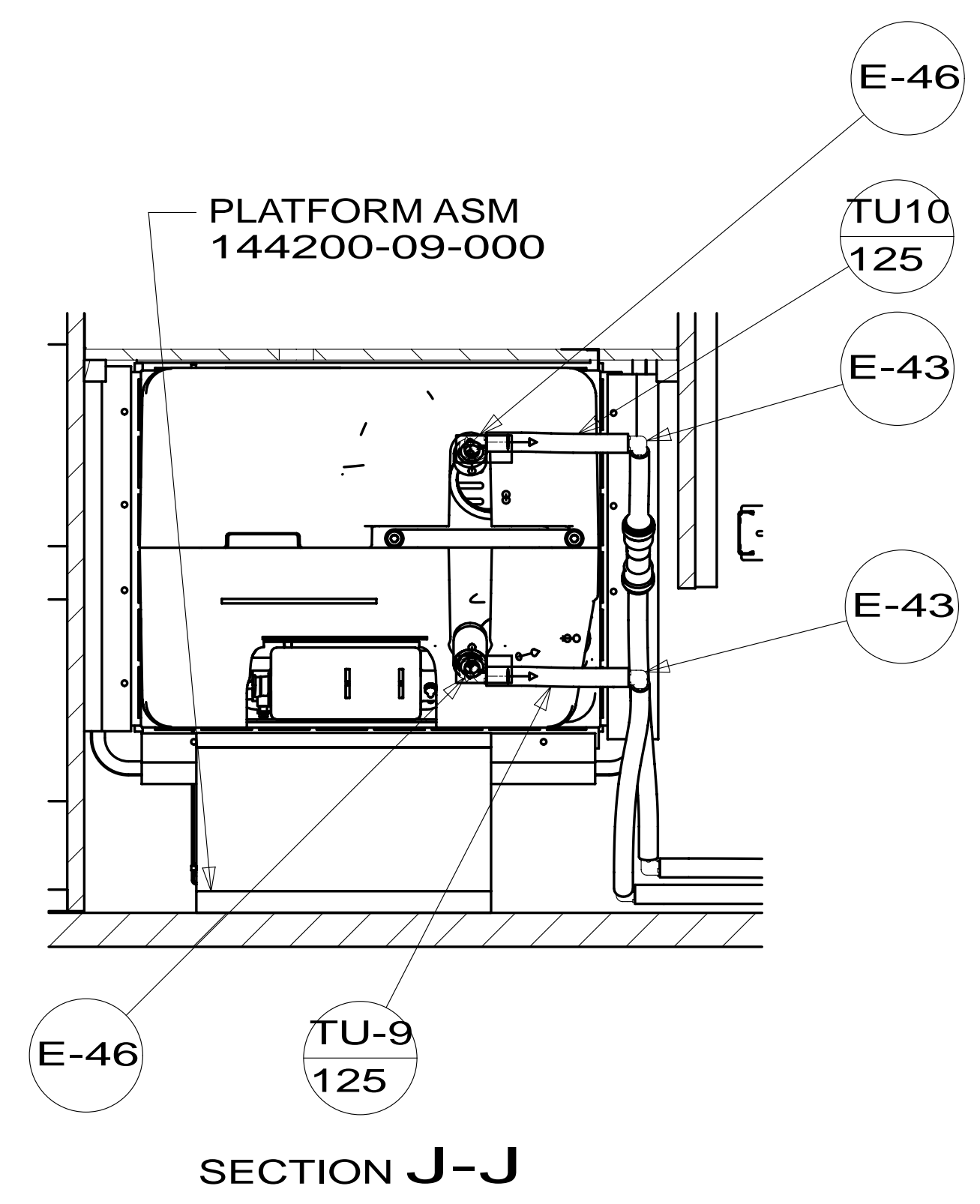
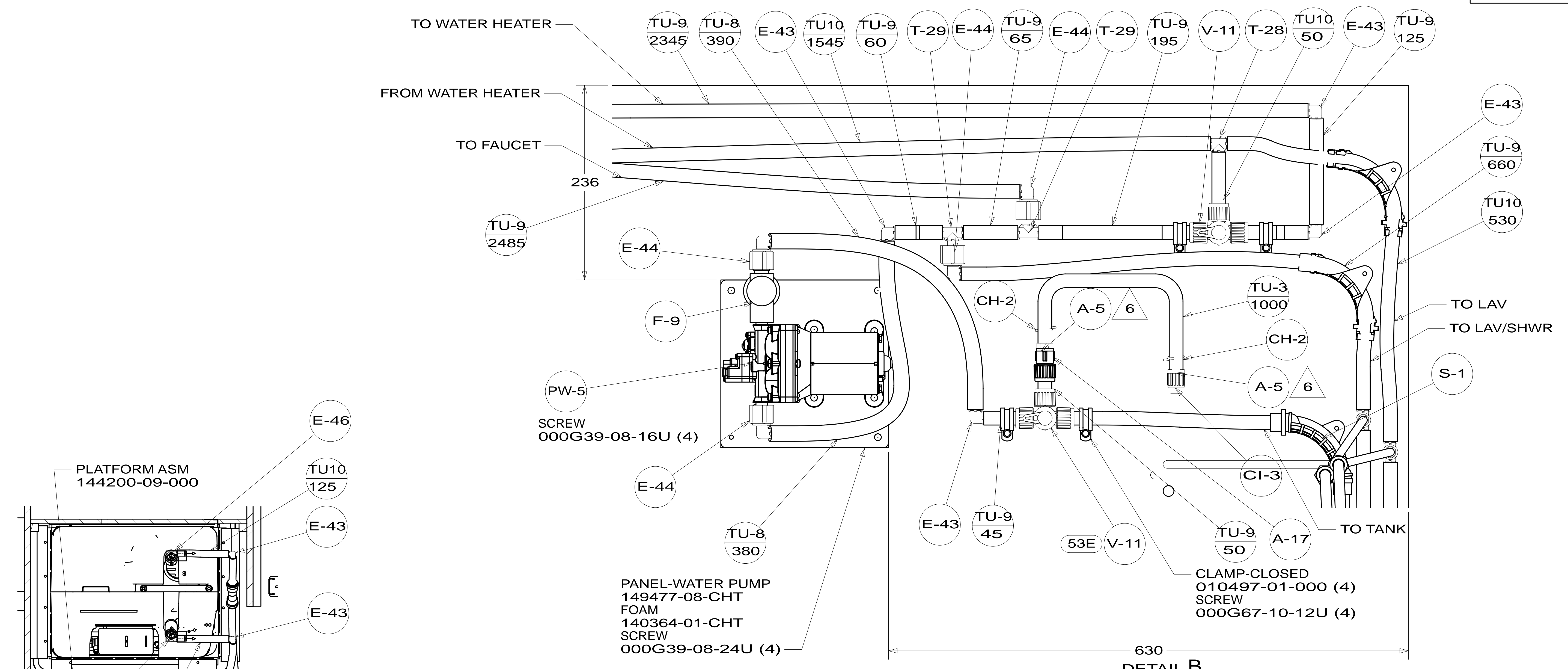

FIRST USED	13 524M	
TITLE:	DO NOT SCALE DRAWING	
TITLE:	WATER SYSTEM INSTL	
SHEET 3	PART NO 180925	REV
1 05-Sep-2013		

\* 180925 \* A

FAUCET-GALLEY  
171482-02-CHT  
WASHER  
000E13-13-00U(2) 10

TU10  
1195

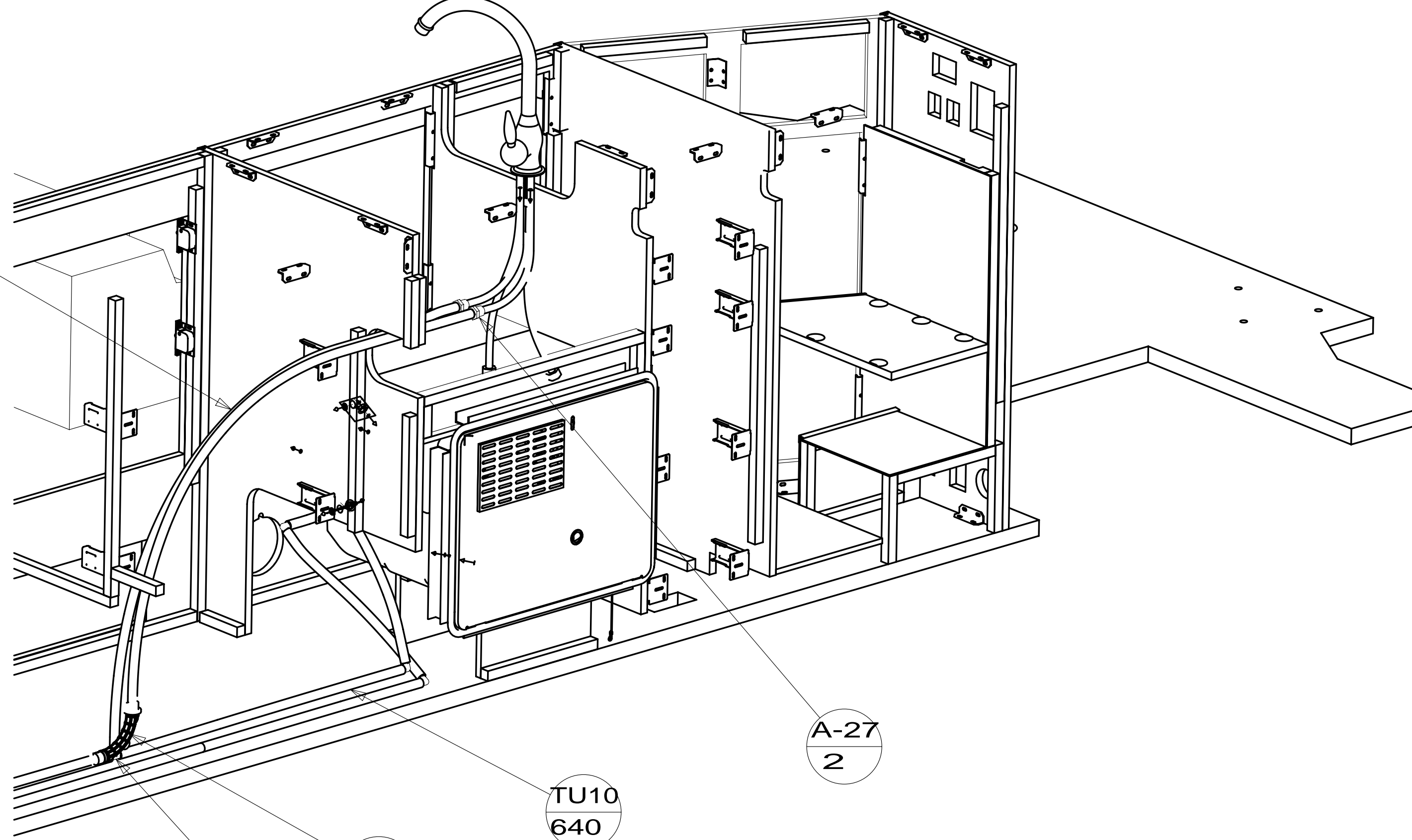

VIEW D

FILTER KIT-WATER,SINK  
160946-03-000  
SCREW  
000G67-10-12U(2) 29B

29B  
R-7  
1370

29B  
C-7

29B  
R-4

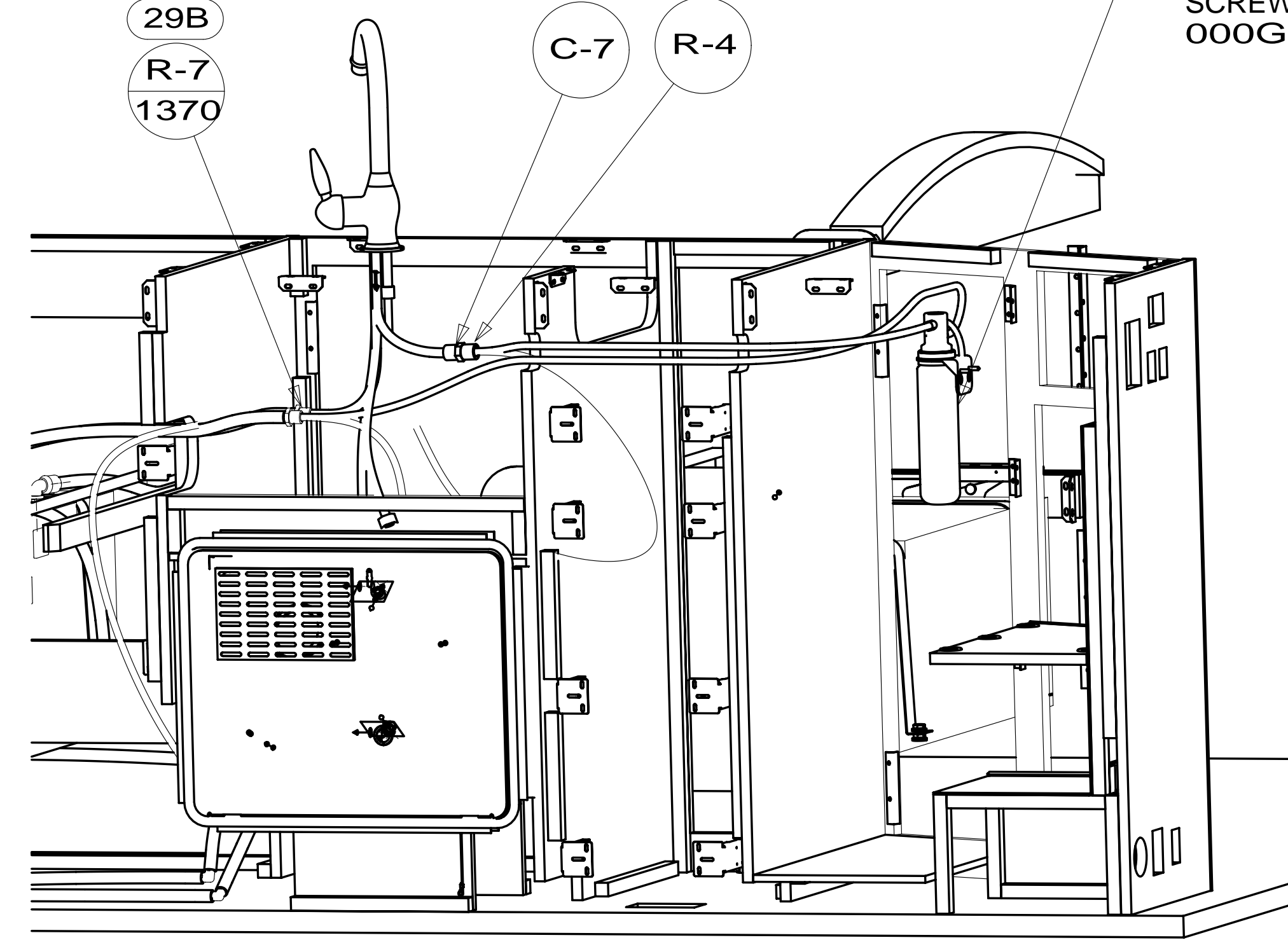

VIEW C

FIRST USED	13 524M		
DO NOT SCALE DRAWING			
TITLE: WATER SYSTEM INSTL			
SHEET 4	PART NO	180925	REV
			1
			05-Sep-2013

\* 180925 \* A



8

7

6

5

4

3

2

1

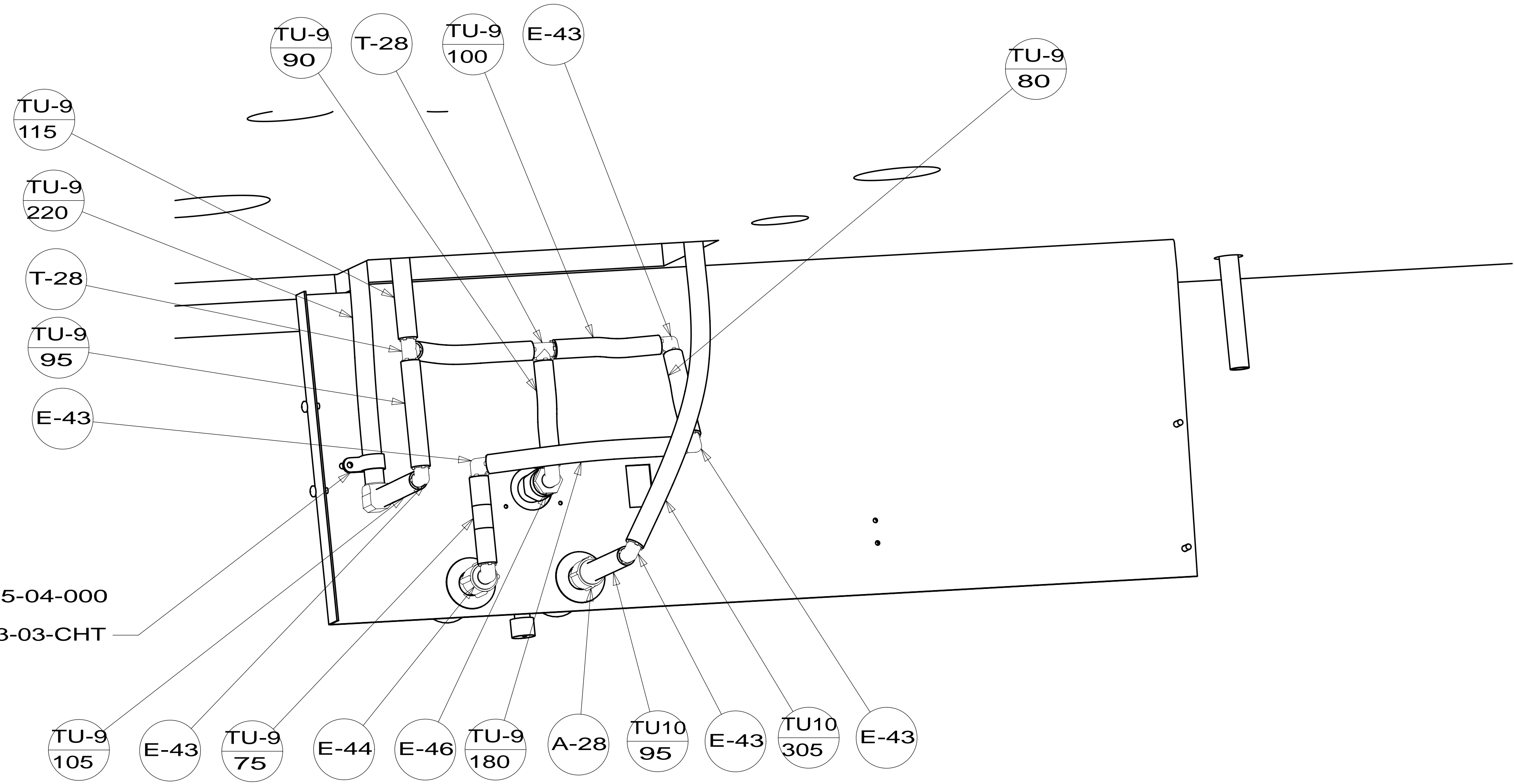

VIEW L

PANEL-SERVICE CENTER  
 151706-12-CHT  
 SCREW  
 000G39-10-08U(8)

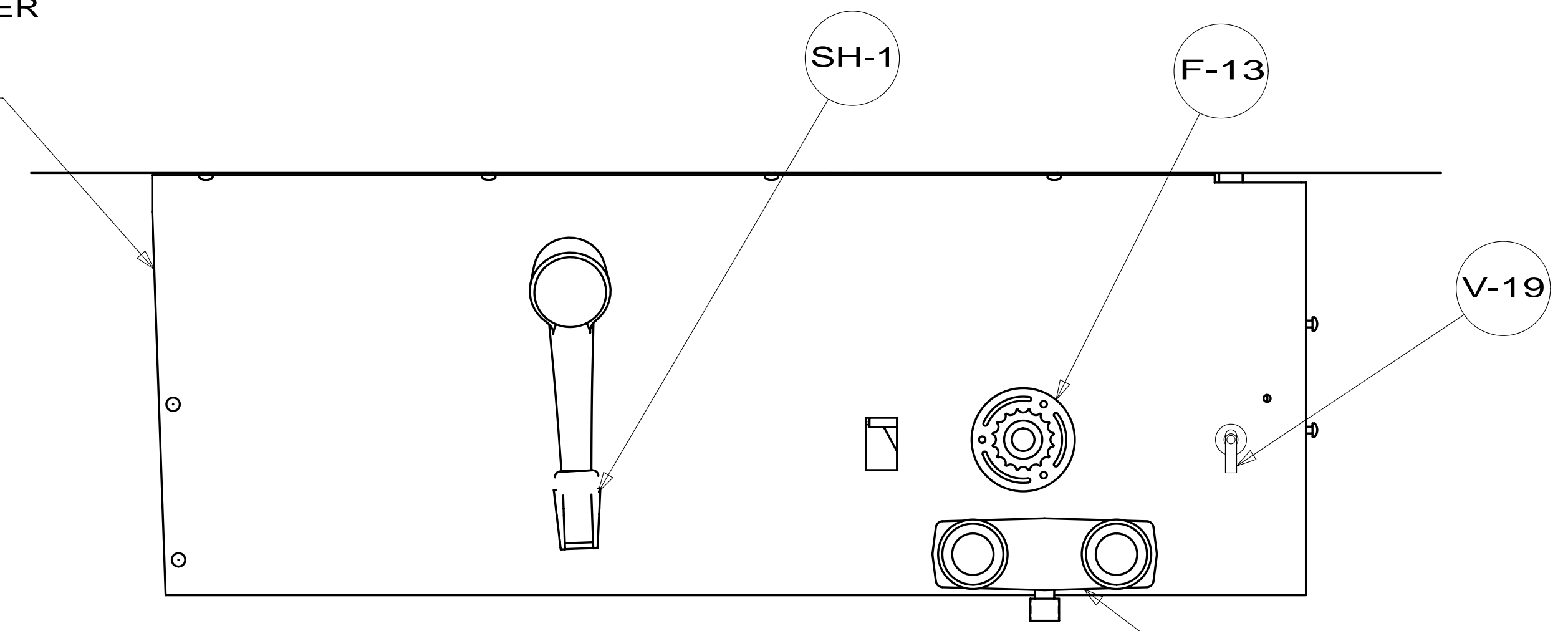

VIEW E

FIRST USED	13 524M		
TITLE:	DO NOT SCALE DRAWING		
TITLE:	WATER SYSTEM INSTL		
SHEET 5	PART NO	180925	REV
	1		05-Sep-2013

\* 180925 \* A