

- 13. VERTICAL LEG OF W-2 CONTINUOUS WASTE NEEDS TO BE CUT DOWN TO 89MM FROM 140MM.
- 12. FOLLOW SEWAGE MACERATOR PUMP WINTERIZATION PROCEDURE. EACH PUMP REQUIRES TWO GALLONS OF RV ANTIFREEZE 157665-02-000.
- 11. PREP THE SURFACE PER MANUFACTURERS INSTRUCTIONS BEFORE APPLYING THE HEATING PAD.
- 10. SEE WIRING INSTL-BODY FOR ELECTRICAL CONNECTION.
- 9. SEE DRAWING 061607 FOR INSTALLATION OF GROMMETS.
- 8. SECURE DRAINAGE PIPES TO CABINET USING WIRE TIE 108046-02-000, AND SCREW 000G67-10-12B AT INTERVALS OF NOT OF NOT MORE THAN 4 FEET APART.
- 7. SECURE VENT PIPE TO FLOOR WITH CLAMP 062401-02-000 (2), SCREW 000G67-10-12B (2), BRACKET 136878-01-CHT (2).
- 6. VENT PIPE MUST PROJECT 51 MIN AND 64 MAX ABOVE ROOF FOR PROPER FIT AND FUNCTION. ADD S-1 (116666-01-CHT SEAL-VENT PIPE) AROUND PIPE ON ROOF BEFORE VENT CAP IS INSTALLED.
- 5. SEAL AROUND SHOWER WITH SILICONE.
- 4. USE SMOOTH PLUMBERS PUTTY 167459-01-000 TO SEAL STRAINER (0.2 PER STRAINER).
- 3. ALL PIPE AND FITTINGS TO BE ASSEMBLED WITH SOLVENT 004020-01-000 (USA), 004020-02-000 (CAN)
- 2. SLOPE OF TRAP ARM MUST BE 6 PER 305 mm.
- 1. SLOPE OF HORIZONTAL PIPING TO BE MINIMUM OF 3 PER 305 mm.

- 1B1 CODES/STANDARDS USA
- 265 CODES/STANDARDS-CSA/CMVSS
- 1JD DRAINAGE SYSTEM-HEATED-W/O
- 23T DRAINAGE SYSTEM-HEATED

<b>WINNEBAGO</b>		COPYRIGHT 2013 WINNEBAGO INDUSTRIES, INC.	
DFT-ORIG	ORIG. DATE	ALL DIMENSIONS ARE IN MILLIMETERS	
CHKR		FIRST USED	
P.E.		13 524G	
M.E.			
DSNR			
UNSPECIFIED TOLERANCES ARE:		MATERIAL:	
WHOLE DIM (X)	: 3		
ONE-PLACE (X.X)	: 1.5		
TWO-PLACE (X.XX)	: 0.50		
ANGLE	: 1°		
THIRD ANGLE PROJECTION			
DO NOT SCALE DRAWING		REFER TO ES0018 FOR FASTENER TIGHTENING GUIDELINES	
TITLE: <b>DRAINAGE SYSTEM INSTL</b>			
SHEET 1 OF 4	PART NO	<b>179978</b>	REV
REF:	1	05-Sep-2013	

FOR  
DRAINAGE  
CALLOUTS  
SEE DWG NO  
116229-01-000

\* 179978 \* A

SINK-LAVATORY  
151679-01-CHT  
SEAL  
091255-03-000(940)  
STRAINER  
163569-01-000

ELBOW  
131486-01-000

TOILET  
160815-04-CHT

SHOWER INSTL  
174125-03-000  
STRAINER  
066440-01-000  
SEALANT  
084456-01-000  
ELBOW  
131486-01-000

FLANGE-CLOSET,ELBOW  
151541-01-000

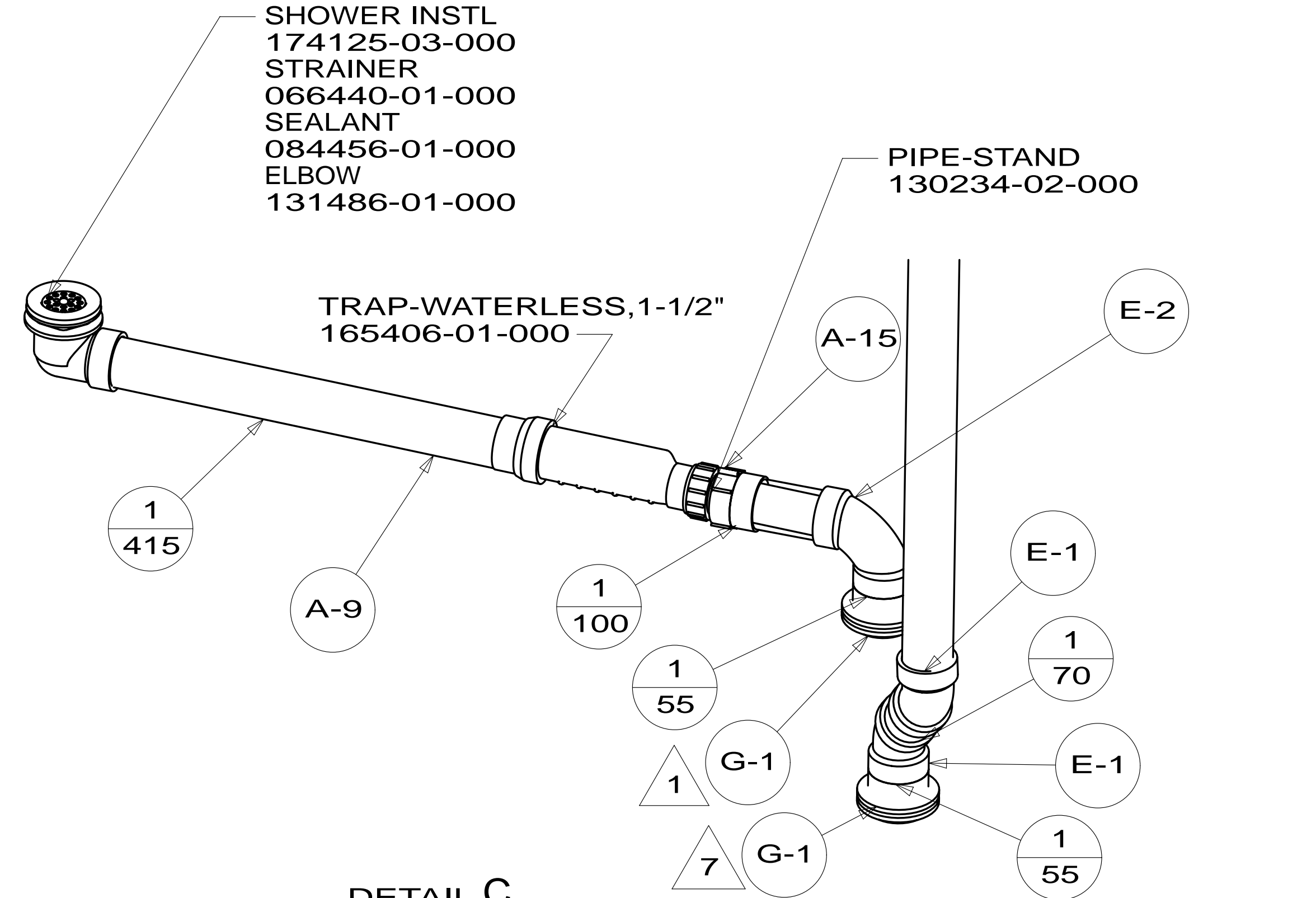
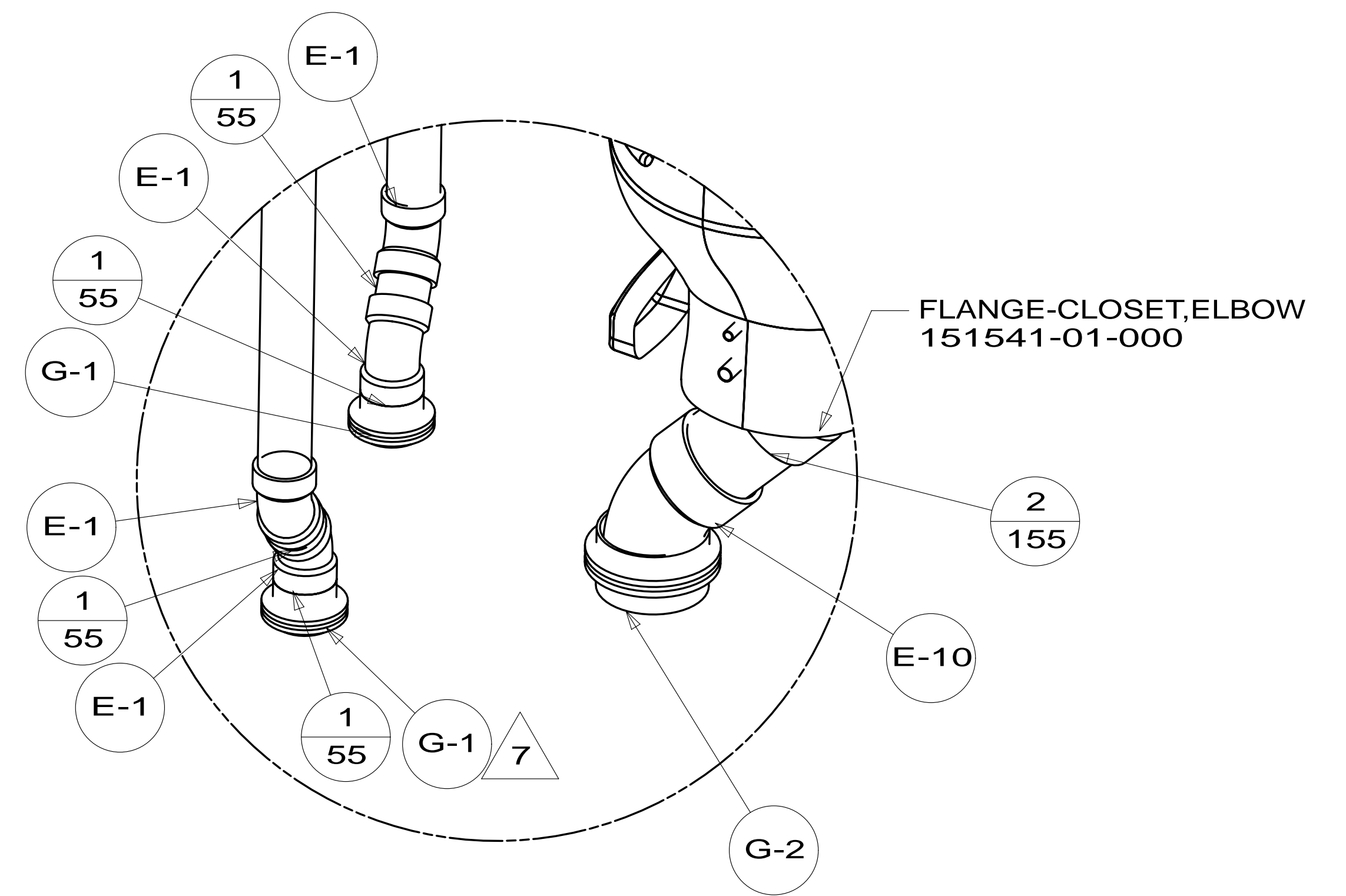
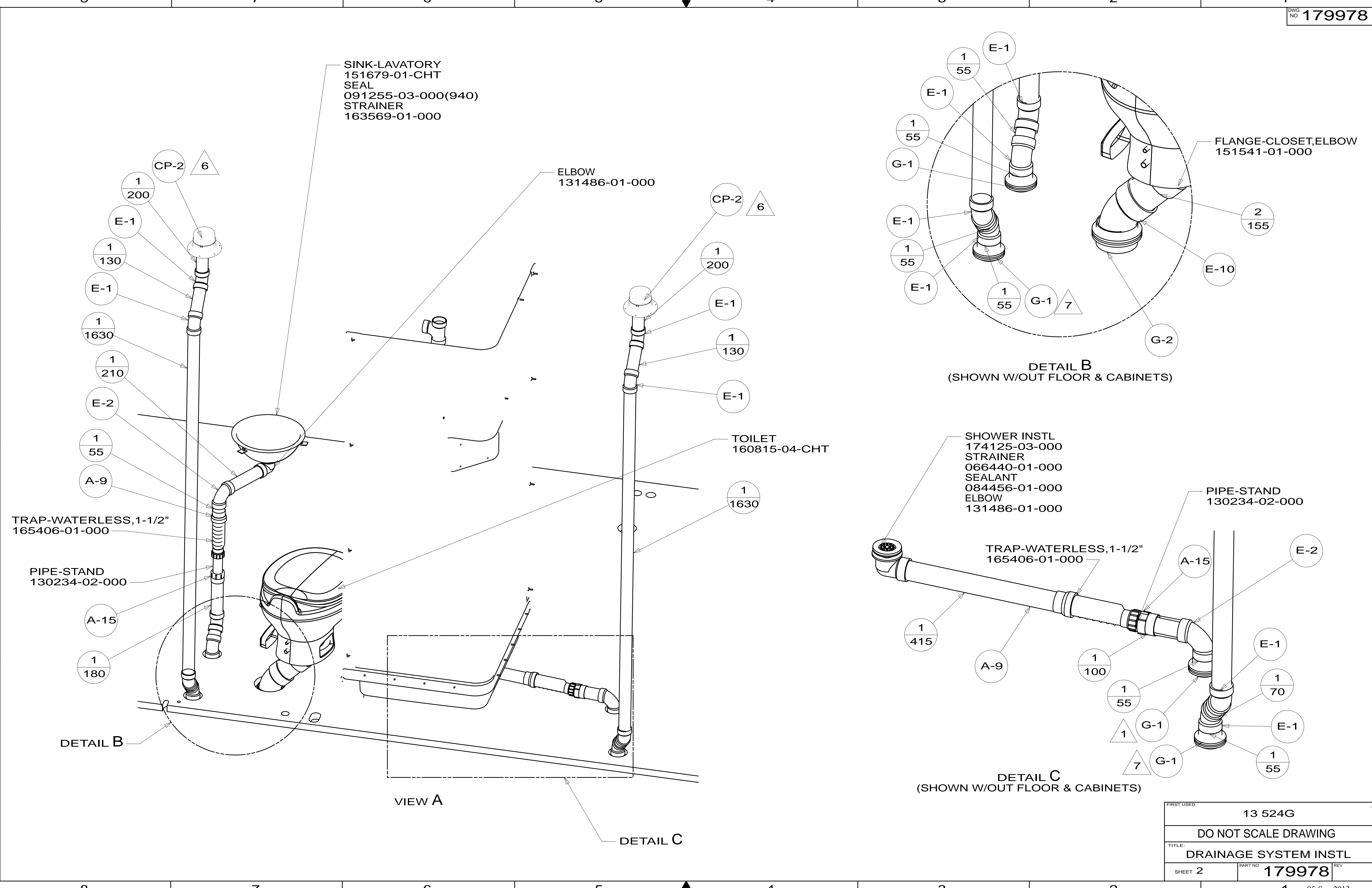

TRAP-WATERLESS,1-1/2"  
165406-01-000

PIPE-STAND  
130234-02-000

FIRST USED	13 524G	
DO NOT SCALE DRAWING		
TITLE: DRAINAGE SYSTEM INSTL		
SHEET 2	PART NO 179978	REV
		05-Sep-2013

\* 179978 \* A

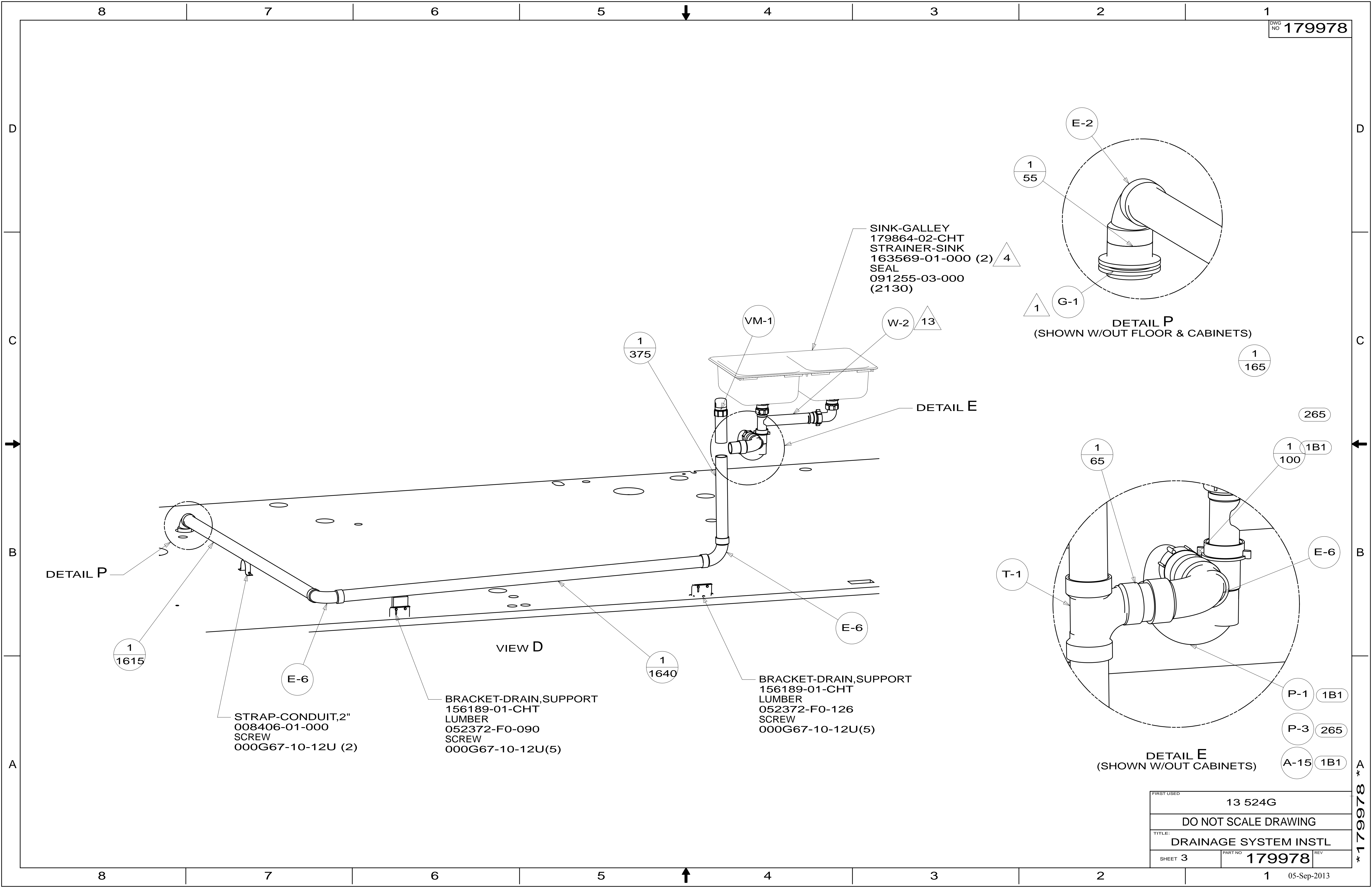

SINK-GALLEY  
179864-02-CHT  
STRAINER-SINK  
163569-01-000 (2) 4  
SEAL  
091255-03-000  
(2130)

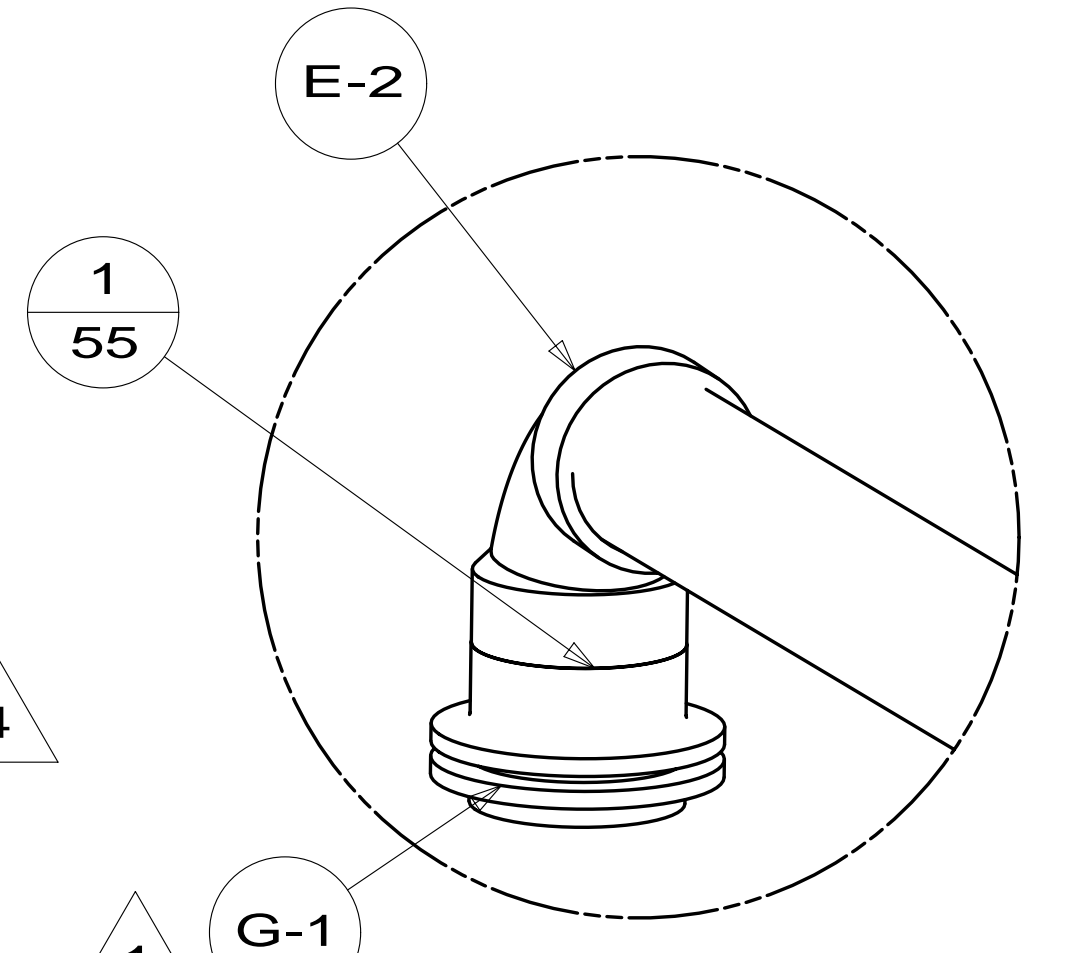

DETAIL P  
(SHOWN W/OUT FLOOR & CABINETS)

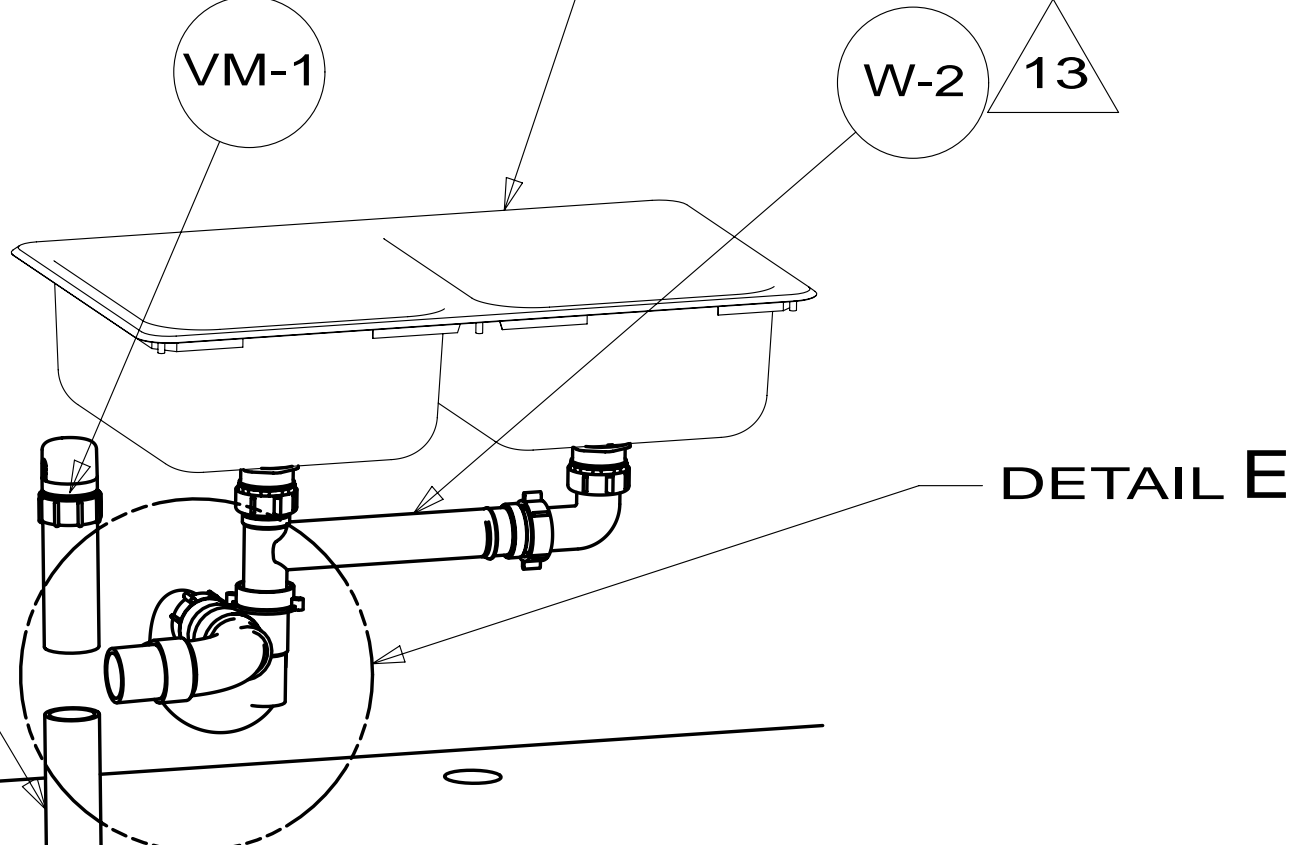

DETAIL E

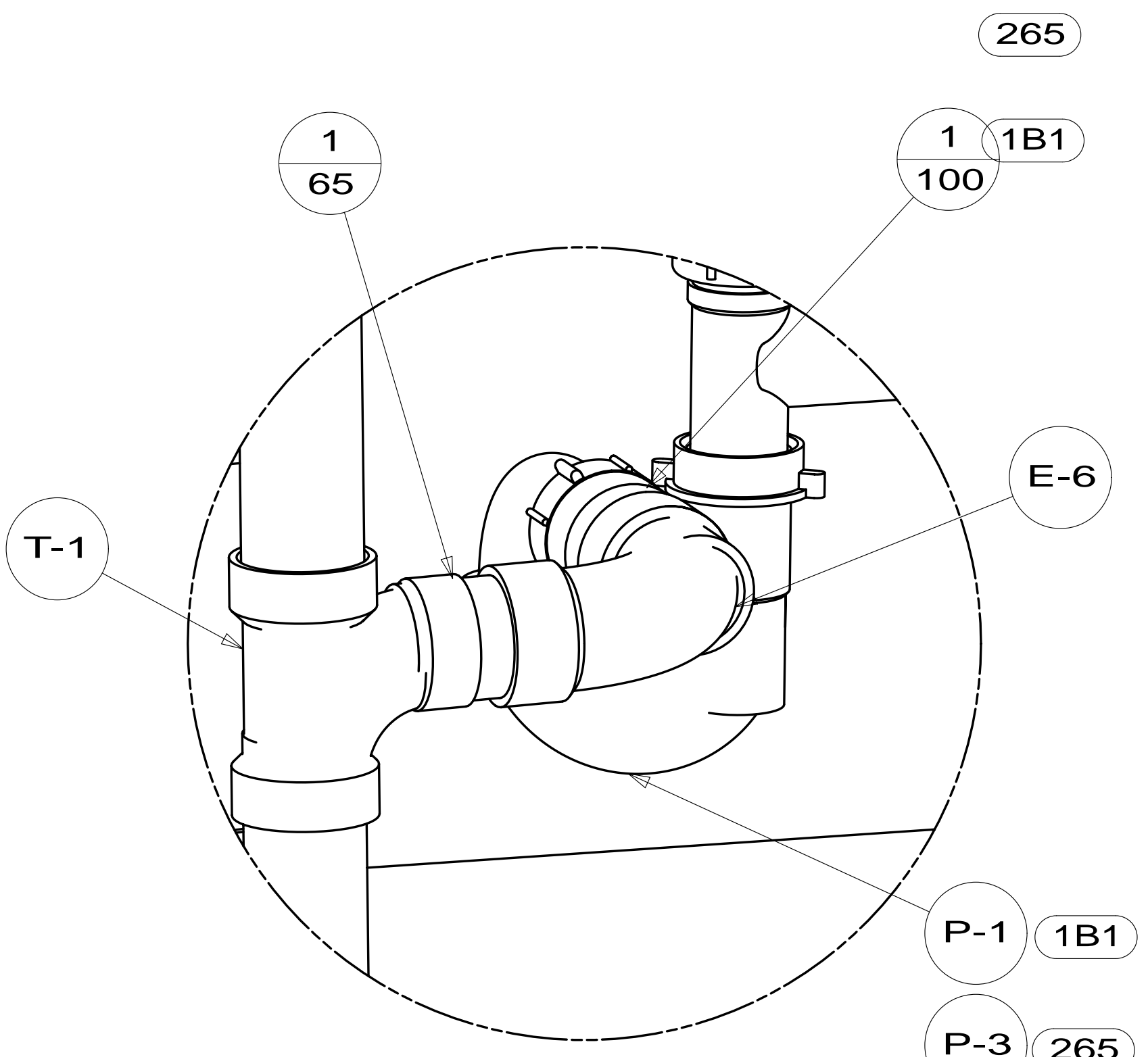

DETAIL E  
(SHOWN W/OUT CABINETS)

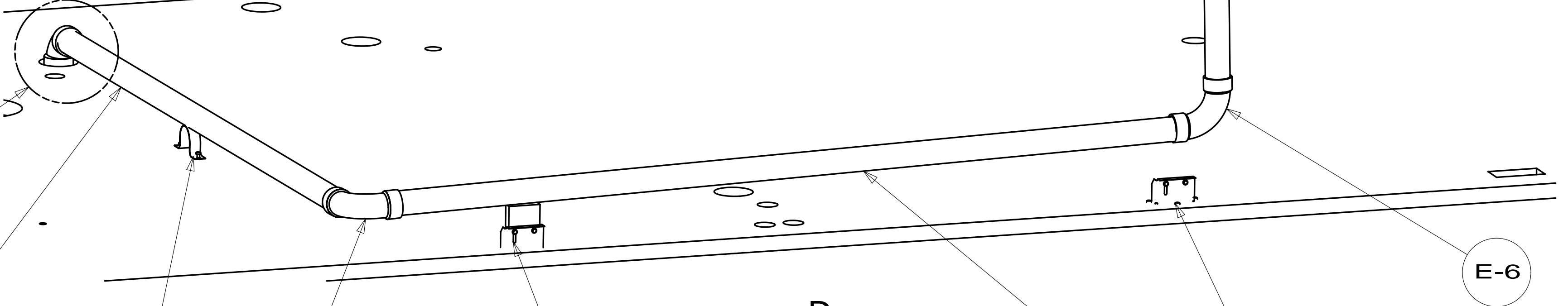

VIEW D

STRAP-CONDUIT,2"  
008406-01-000  
SCREW  
000G67-10-12U (2)

BRACKET-DRAIN,SUPPORT  
156189-01-CHT  
LUMBER  
052372-F0-090  
SCREW  
000G67-10-12U(5)

BRACKET-DRAIN,SUPPORT  
156189-01-CHT  
LUMBER  
052372-F0-126  
SCREW  
000G67-10-12U(5)

FIRST USED	13 524G	
TITLE:	DO NOT SCALE DRAWING	
TITLE:	DRAINAGE SYSTEM INSTL	
SHEET 3	PART NO 179978	REV
		05-Sep-2013

\* 179978 A

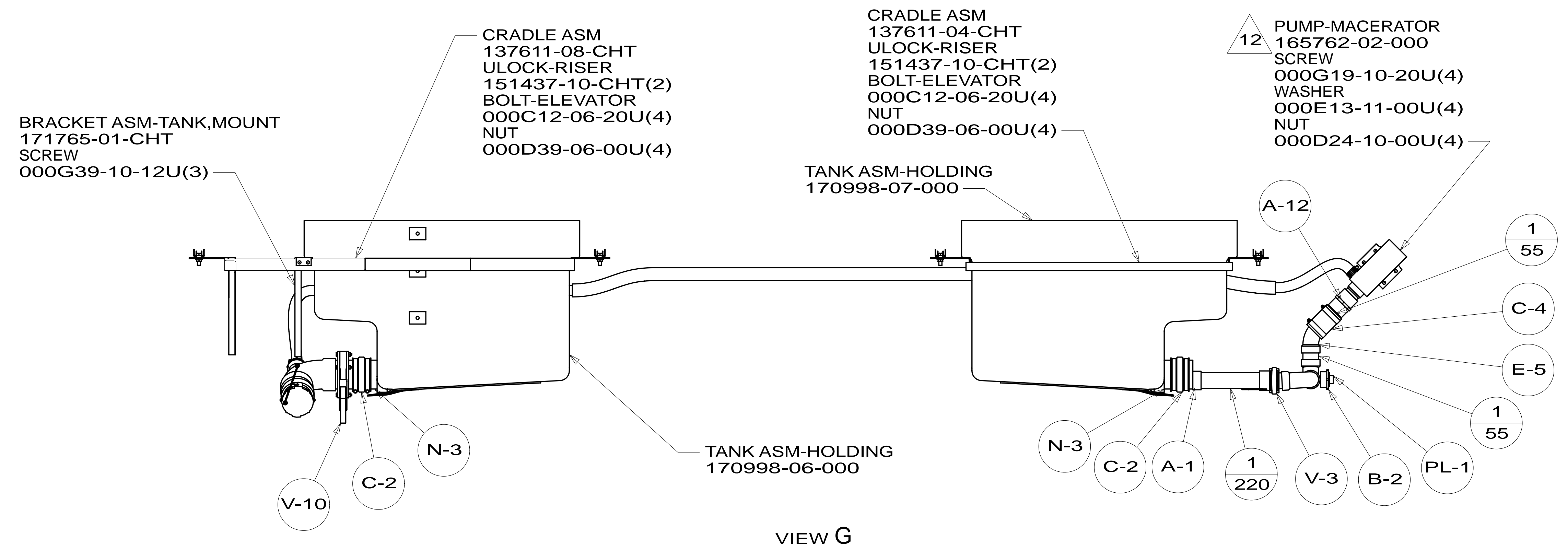

VIEW G

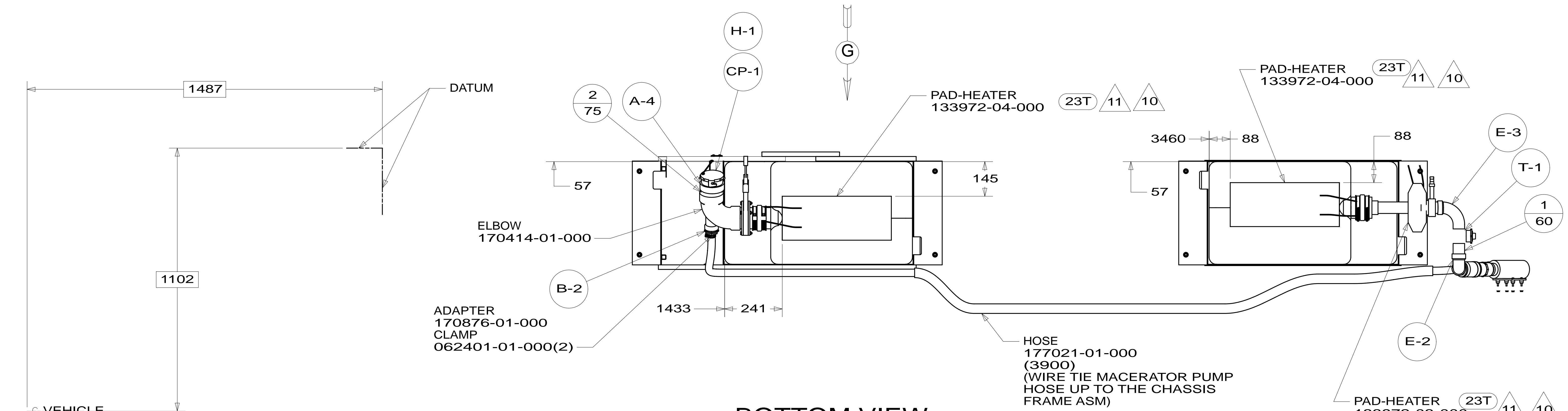

BOTTOM VIEW  
SHOWING ONLY DRAINS AND TANKS

VEHICLE  
FRONT AXLE

FIRST USED	13 524G	
DO NOT SCALE DRAWING		
TITLE: DRAINAGE SYSTEM INSTL		
SHEET 4	PART NO 179978	REV
		05-Sep-2013

\* 179978 \* A

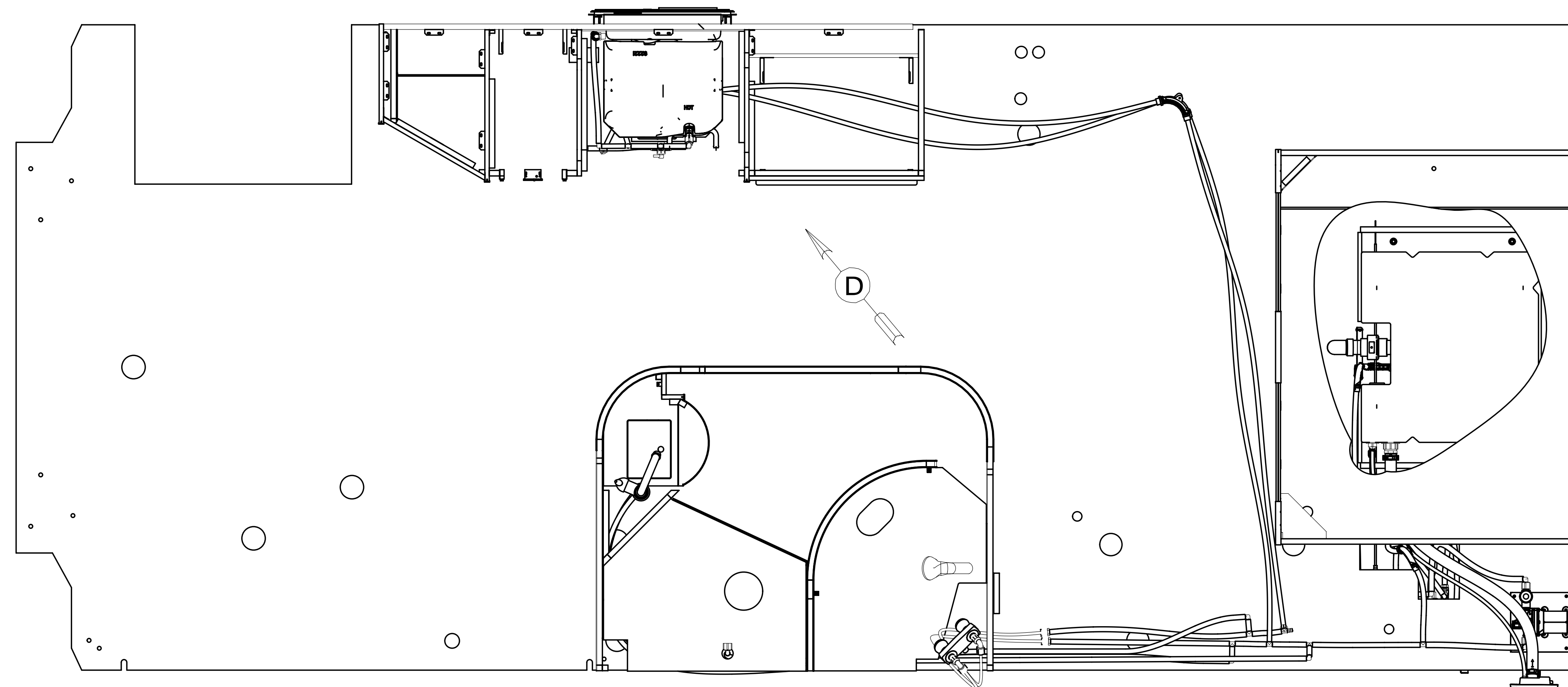

- 10 INSTALL BETWEEN MOUNTING PLATE AND RETAINING NUTS.
- 9 LAVATORY FAUCET TO BE TURNED SO CONTROLS ARE ON LEFT SIDE.
- 8. ALL CRIMP FITTINGS TO 1/2" PEX TUBING REQUIRE 1/2" CLAMP 140171-03-000.
- 7. ALL CRIMP FITTINGS TO 5/8" PEX TUBING REQUIRE 5/8" CLAMP 140171-04-000.
- 6 LABEL HOT AND COLD SUPPLY TUBES AND TAPE FITTING TO TUBE BEFORE CABINET SET TO PREVENT MOVEMENT.
- 5 ADD PIPE WRAP (LADDER SCRAP 110157-02-000) INSULATION.
- 4 ADD TEFLON TAPE 010405-02-000.
- 3. ALL TUBING TO BE SECURED AT 1200 INTERVALS MAXIMUM WITH CLAMP 010495-01-000 AND SCREW 000G67-10-12B OR EQUIVALENT.
- 2. TUBING TO BE INSTALLED WITH SUFFICIENT SLOPE TO PROVIDE DRAINAGE TO NEAREST VALVE.
- 1. PLASTIC FITTINGS TO BE SEALED WITH SEALANT 084456-01-000.

- 1J4 EXT WASH STATION - WITHOUT
- 64R EXTERIOR WASH STATION
- 53E WINTERIZATION PACKAGE
- 501 WATER PURIFIER WITHOUT
- 29B WATER PURIFIER

<b>WINNEBAGO</b>		COPYRIGHT 2013 WINNEBAGO INDUSTRIES, INC.	
DFT-ORIG	ORIG. DATE	ALL DIMENSIONS ARE IN MILLIMETERS	
CHKR		FIRST USED	
P.E.		13 524G	
M.E.		UNSPECIFIED TOLERANCES ARE:	
DSNR		WHOLE DIM (X)	: 3
		ONE-PLACE (X.X)	: 1.5
		TWO-PLACE (X.XX)	: 0.50
		ANGLE	: 1°
THIRD ANGLE PROJECTION		MATERIAL:	
DO NOT SCALE DRAWING		REFER TO ES0018 FOR FASTENER TIGHTENING GUIDELINES	
TITLE: WATER SYSTEM INSTL			
SHEET 1 OF 5	PART NO	179996	REV
REF:	1	20-Aug-2013	

FOR WATER CALLOUTS SEE DWG NO 116230-01-000

NOTES:

\* 179996 \*

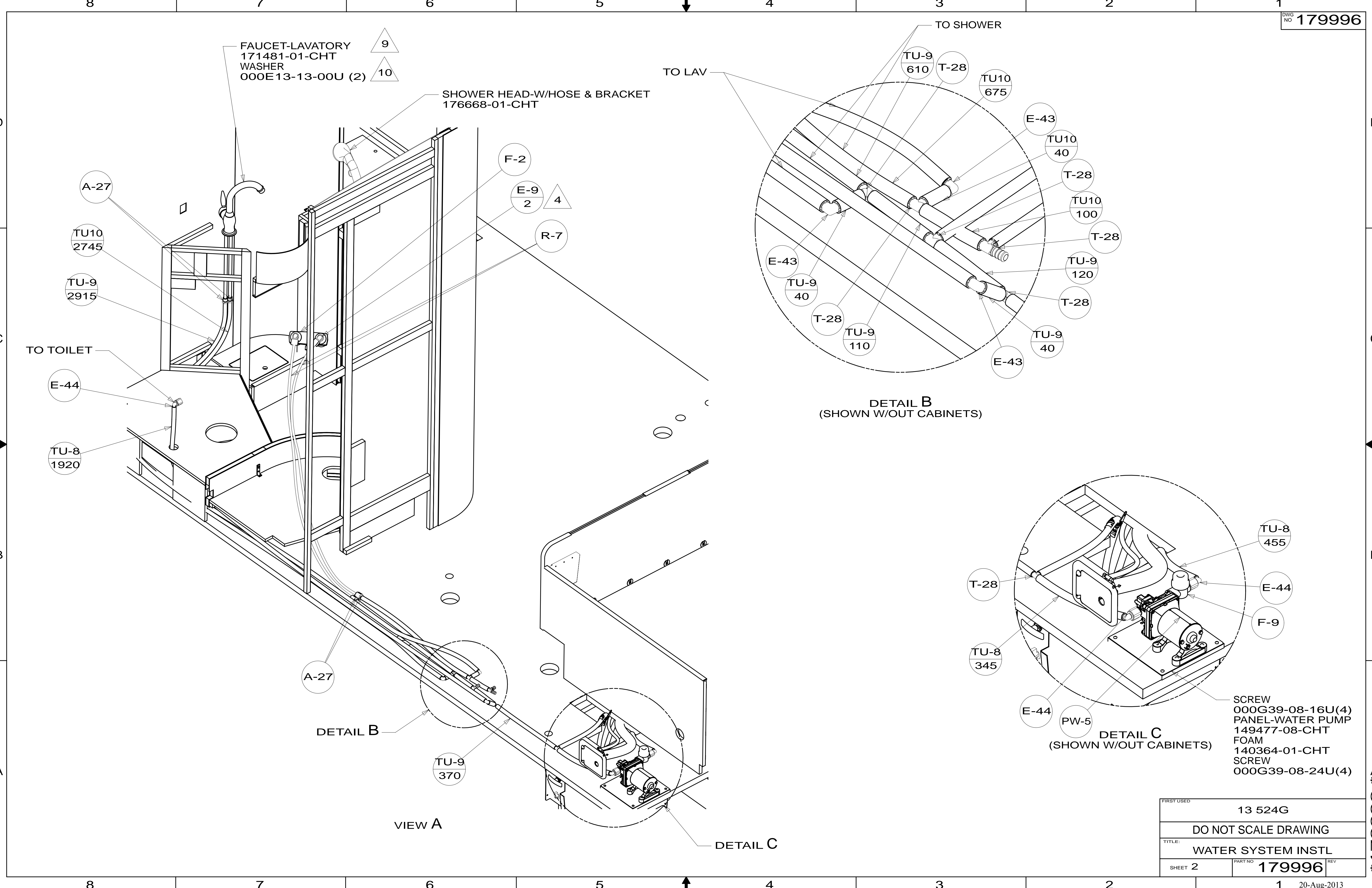

FIRST USED	13 524G	
TITLE:	DO NOT SCALE DRAWING	
TITLE:	WATER SYSTEM INSTL	
SHEET 2	PART NO 179996	REV
20-Aug-2013		

\* 179996

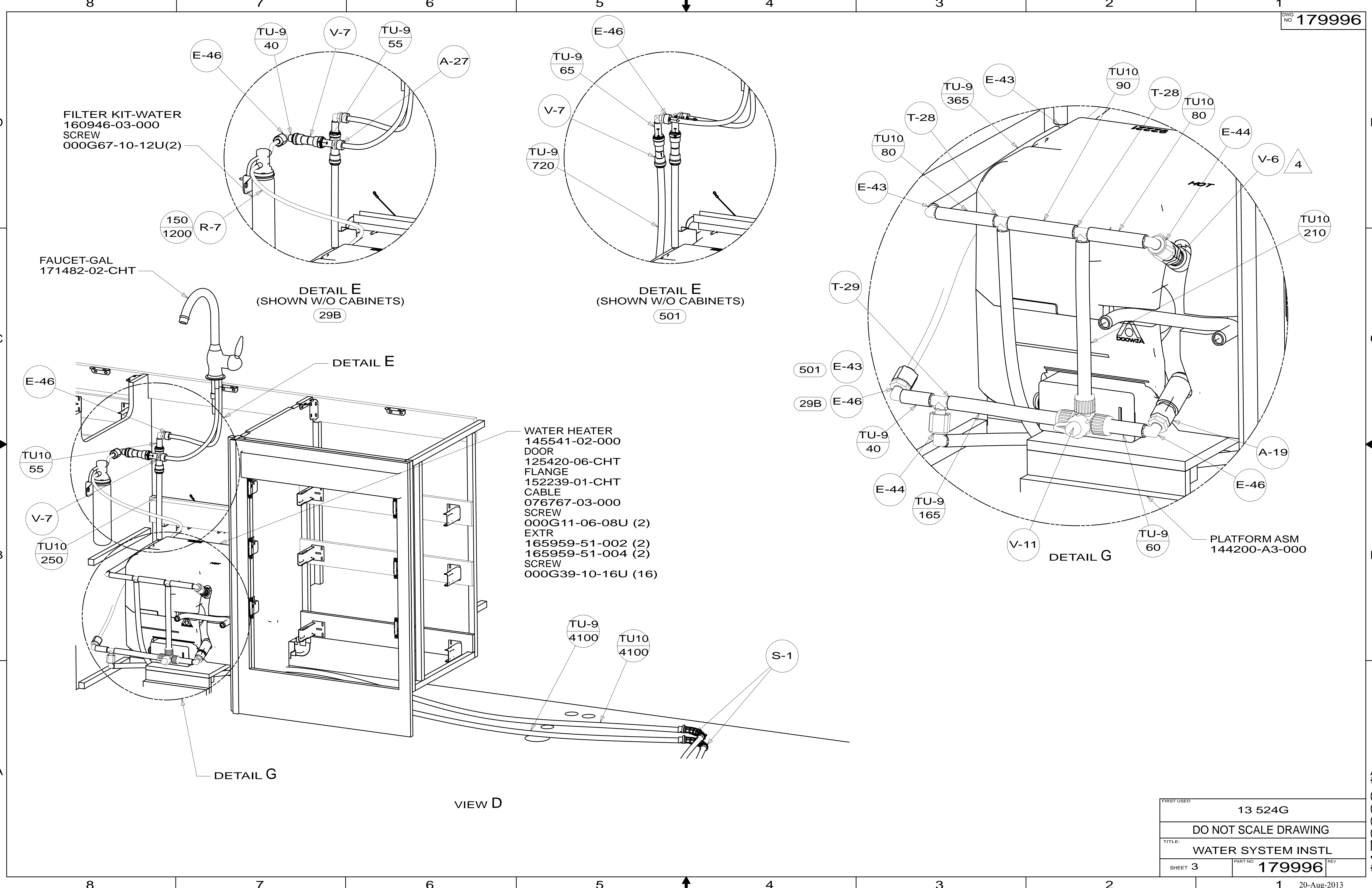

FILTER KIT-WATER  
160946-03-000  
SCREW  
000G67-10-12U(2)

FAUCET-GAL  
171482-02-CHT

DETAIL E  
(SHOWN W/O CABINETS)  
29B

DETAIL E  
(SHOWN W/O CABINETS)  
501

WATER HEATER  
145541-02-000  
DOOR  
125420-06-CHT  
FLANGE  
152239-01-CHT  
CABLE  
076767-03-000  
SCREW  
000G11-06-08U (2)  
EXTR  
165959-51-002 (2)  
165959-51-004 (2)  
SCREW  
000G39-10-16U (16)

DETAIL G

VIEW D

FIRST USED	13 524G		
TITLE:	DO NOT SCALE DRAWING		
SHEET 3	PART NO	179996	REV
			20-Aug-2013

\* 179996 \* A

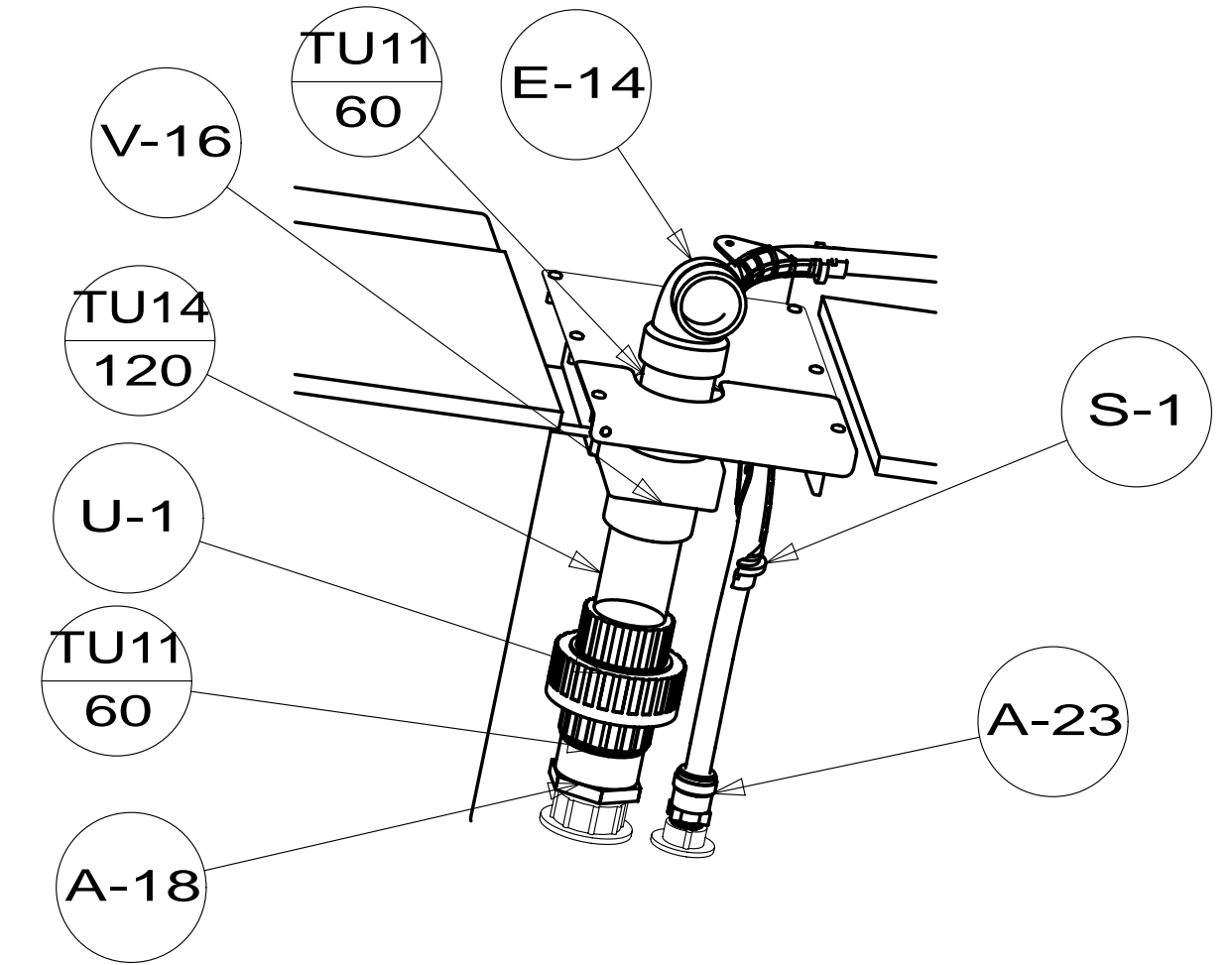

TANK ASM-WATER  
180272-02-000  
STRAP-TANK,WATER  
118994-15-CHT (2)  
WASHER  
000E13-18-00U (4)  
NUT  
000D39-06-00U (8)

INSULATION  
120050-37-000 (2)

INSULATION  
168508-53-000

INSULATION-DRAINAGE COMPT  
168508-55-000

PANEL-ACCESS  
133352-02-CHT  
SCREW  
000G39-08-12U (4)

PANEL-CLOSEOUT,DRAINAGE  
151869-05-CHT  
SCREW  
000G39-08-12U (2)

**VIEW ONLY SHOWING TANK  
AND UNDER FLOOR**

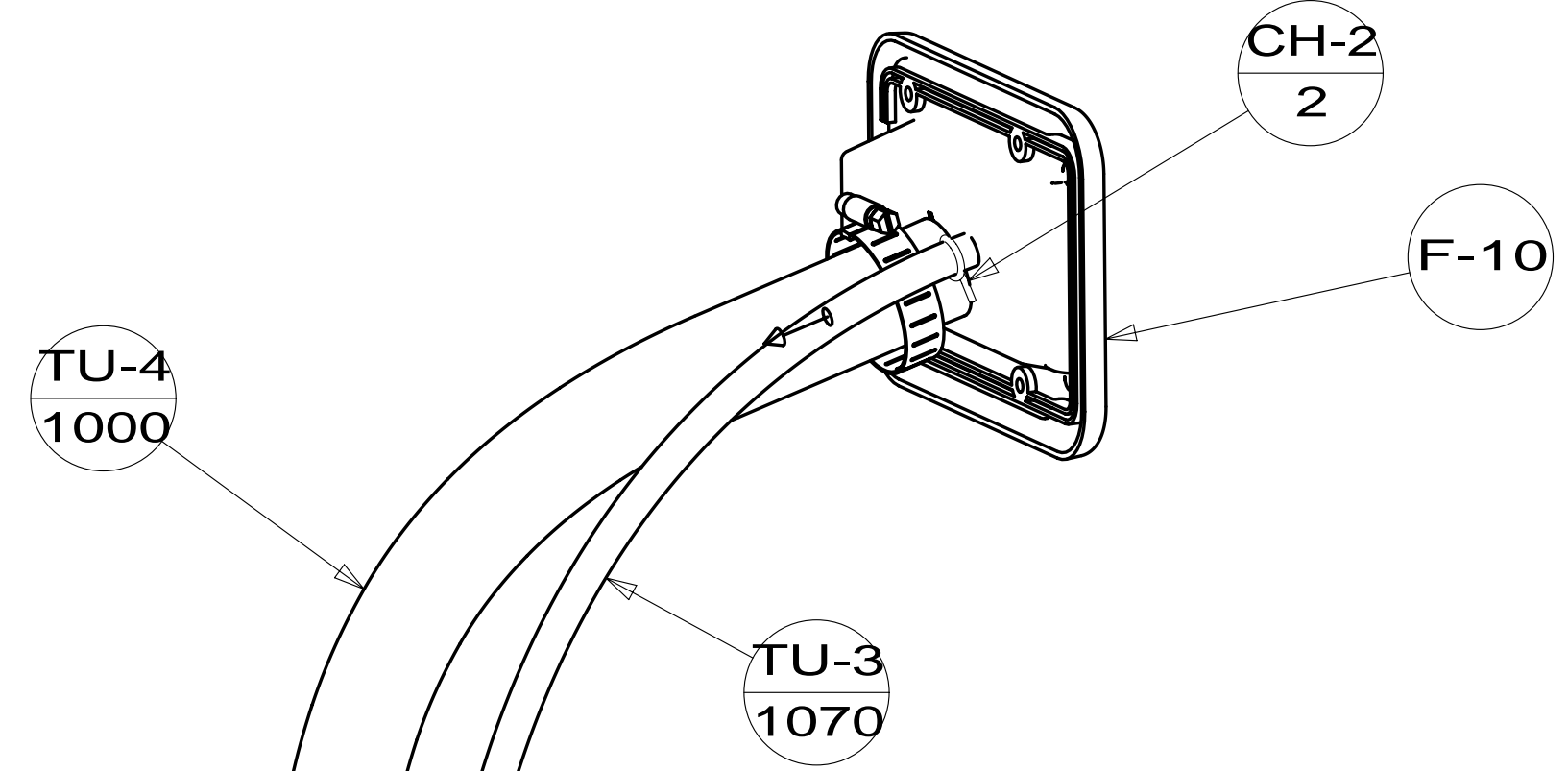

TU-9  
1280

A-13

TU-9  
575

TU-9  
90

TU-9  
100

E-43

TU-9  
85

53E

DETAIL K

CLAMP  
010495-04-000 (2)  
RIVET  
113133-03-CHT (2)

INSULATION-DRAINAGE COMPT  
168508-52-000 (2)

INSULATION-DRAINAGE COMPT  
168508-54-000

FIRST USED	13 524G	
TITLE:	DO NOT SCALE DRAWING	
TITLE:	WATER SYSTEM INSTL	
SHEET 4	PART NO 179996	REV

\* 179996



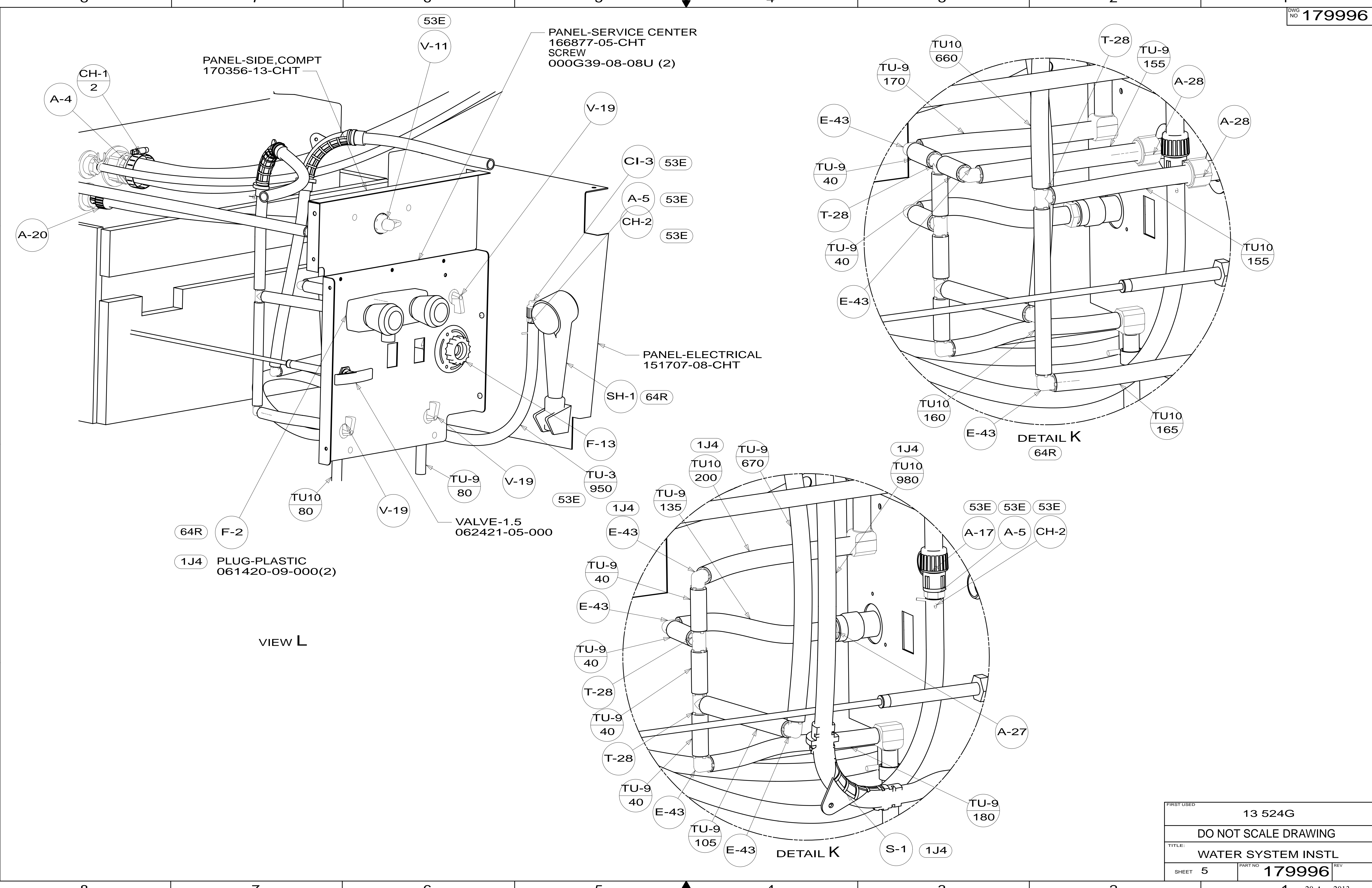

FIRST USED	13 524G		
DO NOT SCALE DRAWING			
TITLE:	WATER SYSTEM INSTL		
SHEET 5	PART NO	179996	REV
		1	20-Aug-2013

\* 179996 \* A