

DWG NO	DETAIL	MODEL
179937-01	G	231W
179937-02	F	231WP

RELEASE	REV DATE	DWG NO	179937
REV ZONE	REVISION RECORD	DATE	DFT-ORIG

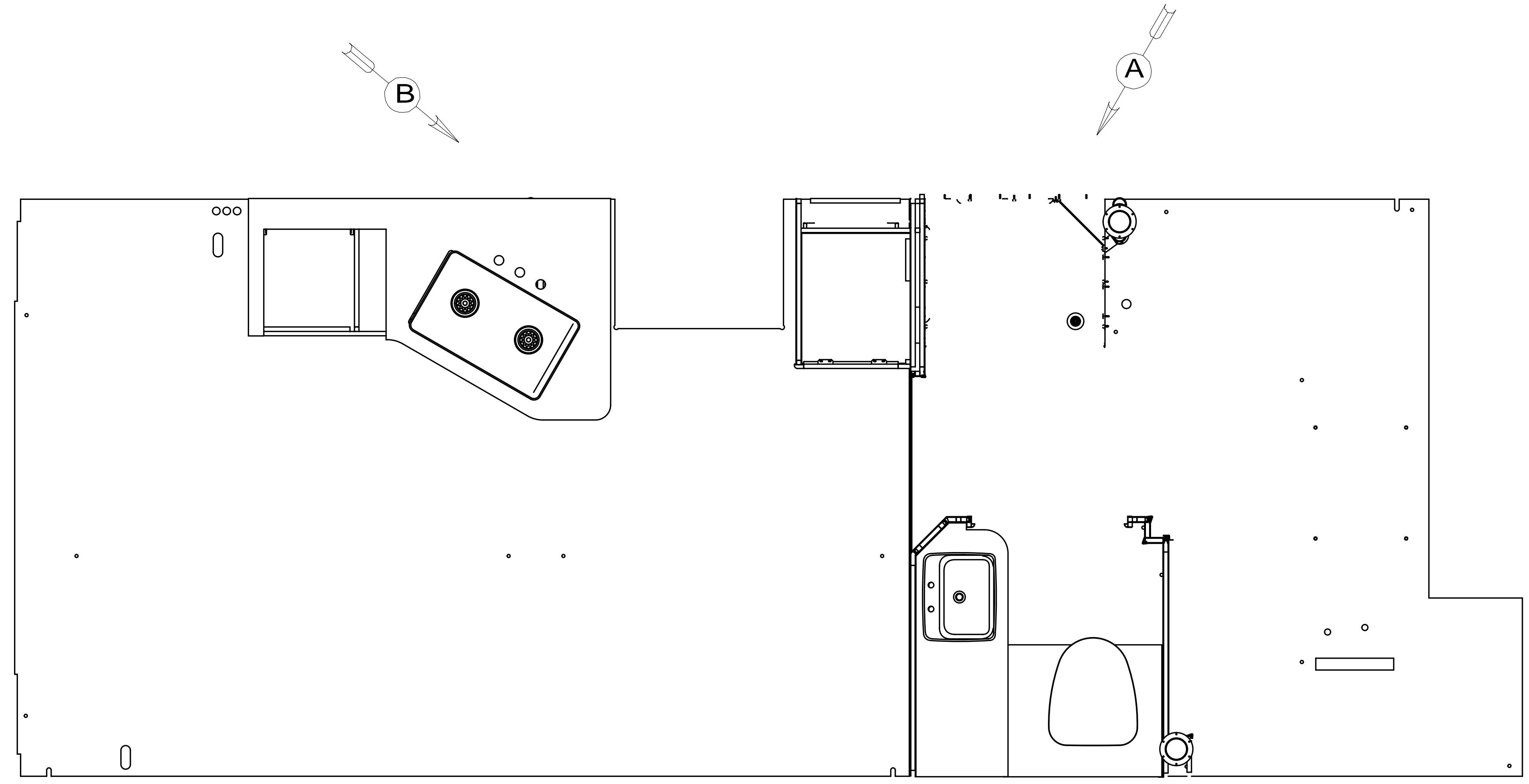

- NOTES:
11. PREP THE SURFACE PER MANUFACTURERS INSTRUCTIONS BEFORE APPLYING THE HEATING PAD.
 10. SEE WIRING INSTL-BODY FOR ELECTRICAL CONNECTION.
 9. SEE DRAWING 061607 FOR INSTALLATION OF GROMMETS.
 8. SECURE DRAINAGE PIPES TO CABINET USING WIRE TIE 108046-02-000, AND SCREW 000G67-10-12U AT INTERVALS OF NOT OF NOT MORE THAN 4 FEET APART.
 7. SECURE VENT PIPE TO FLOOR WITH CLAMP 062401-02-000 (2), SCREW 000G67-10-12U (2), BRACKET 136878-01-CHT (2).
 6. VENT PIPE MUST PROJECT 51 MIN AND 64 MAX ABOVE ROOF FOR PROPER FIT AND FUNCTION. ADD S-1 (116666-01-CHT SEAL-VENT PIPE) AROUND PIPE ON ROOF BEFORE VENT CAP IS INSTALLED.
 5. SEAL AROUND SHOWER WITH SILICONE.
 4. USE SMOOTH PLUMBERS PUTTY 167459-01-000 TO SEAL STRAINER (0.2 PER STRAINER).
 3. ALL PIPE AND FITTINGS TO BE ASSEMBLED WITH SOLVENT 004020-01-000 (USA), 004020-02-000 (CAN)
 2. SLOPE OF TRAP ARM MUST BE 6 PER 305 mm.
 1. SLOPE OF HORIZONTAL PIPING TO BE MINIMUM OF 3 PER 305 mm.

- 43E TOILET-PORCELAIN-ROUND
- 265 CODES/STANDARDS-CSA/CMVSS
- 23T DRAINAGE SYSTEM-HEATED
- 1B1 CODES/STANDARDS USA

WINNEBAGO		COPYRIGHT 2013 WINNEBAGO INDUSTRIES, INC.	
DFT-ORIG	ORIG. DATE	ALL DIMENSIONS ARE IN MILLIMETERS	
CHKR			
P.E.			
M.E.	FIRST USED	13 231W	
DSNR			
UNSPECIFIED TOLERANCES ARE:		MATERIAL:	
WHOLE DIM (X)	: 3		
ONE-PLACE (X.X)	: 1.5		
TWO-PLACE (X.XX)	: 0.50		
ANGLE	: 1°		
THIRD ANGLE PROJECTION			
DO NOT SCALE DRAWING		REFER TO ES0018 FOR FASTENER TIGHTENING GUIDELINES	
TITLE: DRAINAGE SYSTEM INSTL			
SHEET 1 OF 5	PART NO	179937	REV
REF:	1	29-Apr-2013	

FOR
DRAINAGE
CALLOUTS
SEE DWG NO
116229-01-000

* 179937 * A

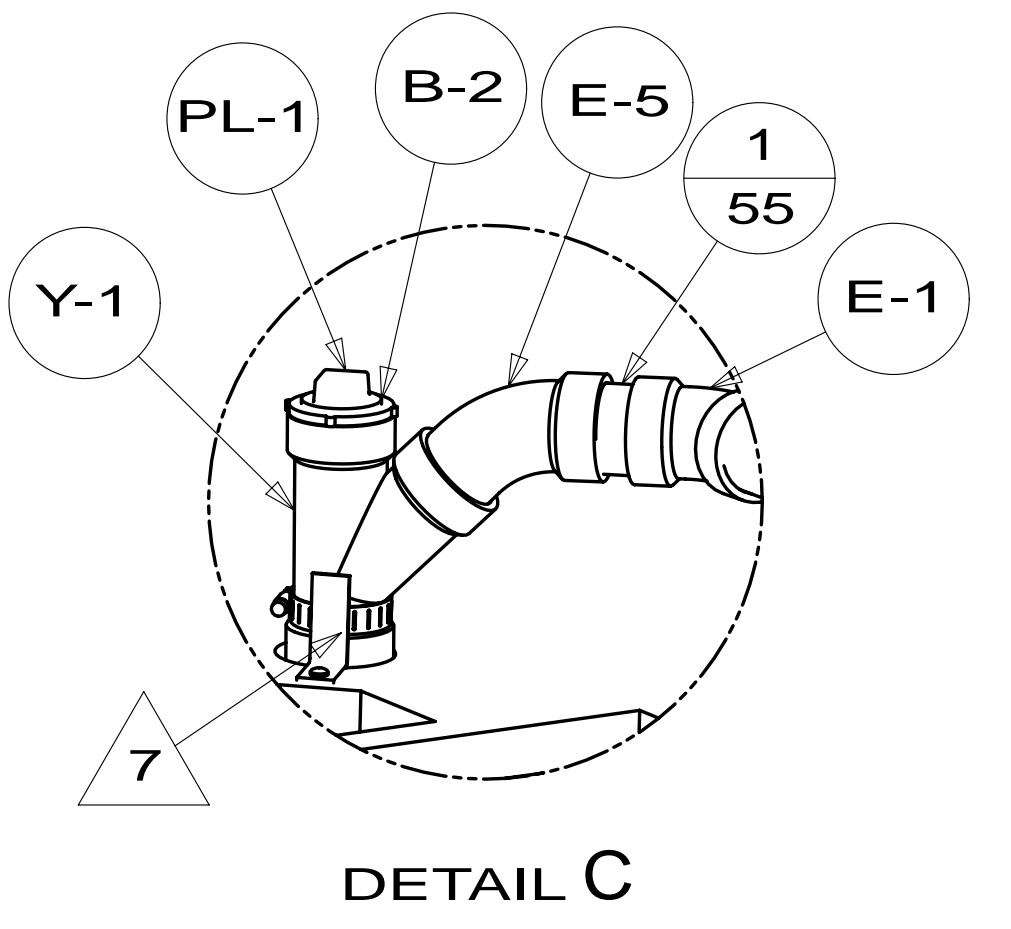
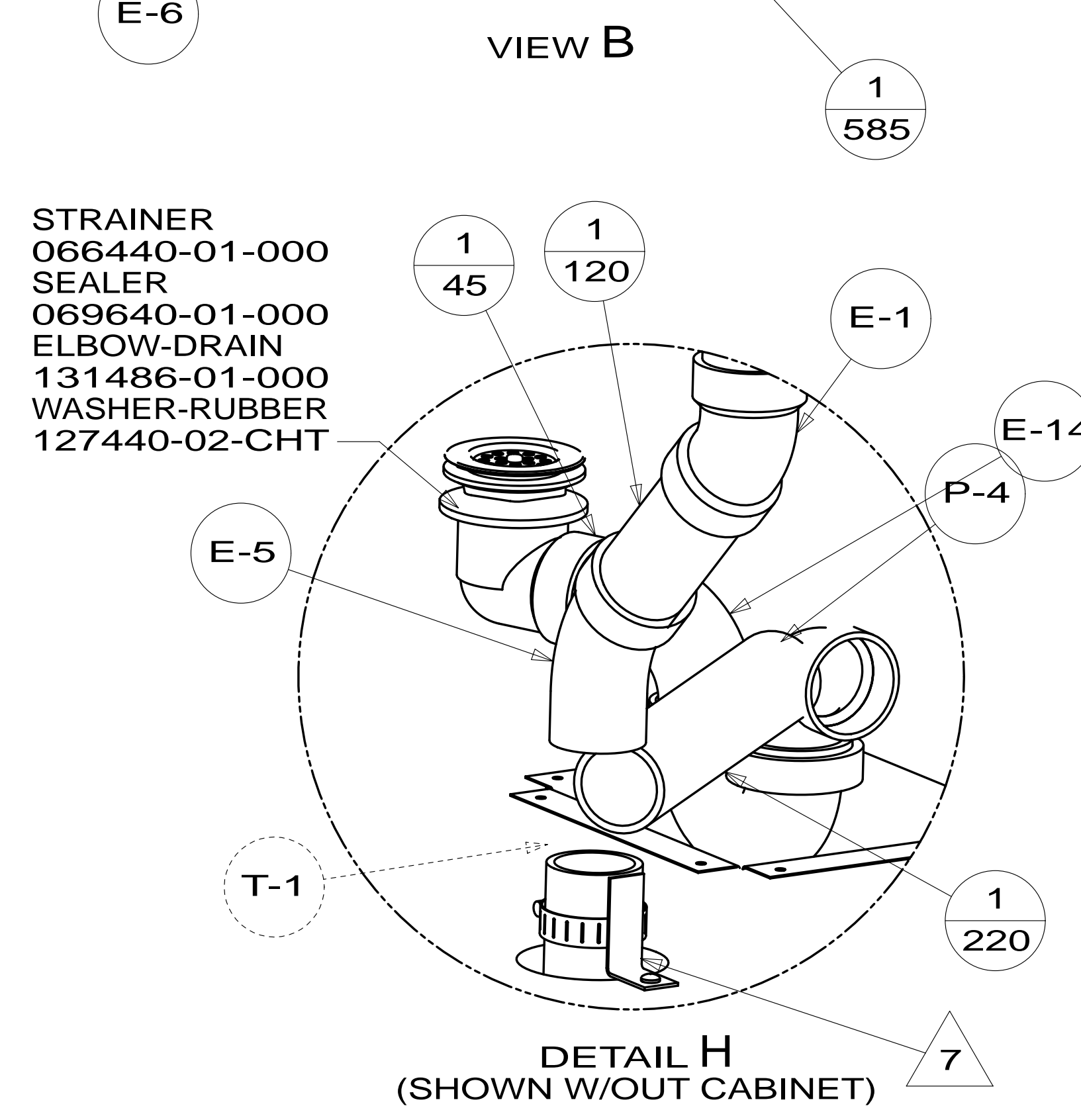
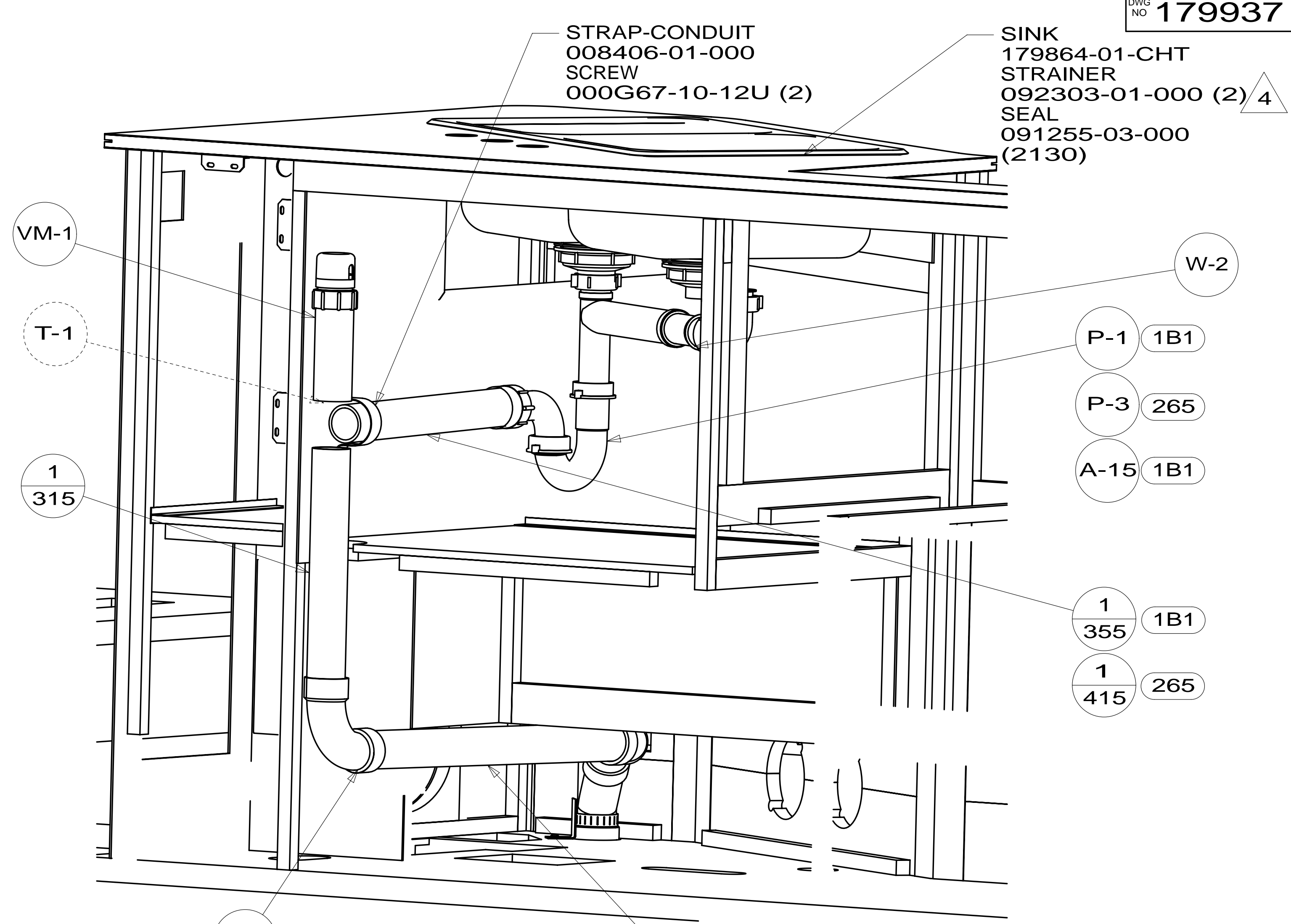
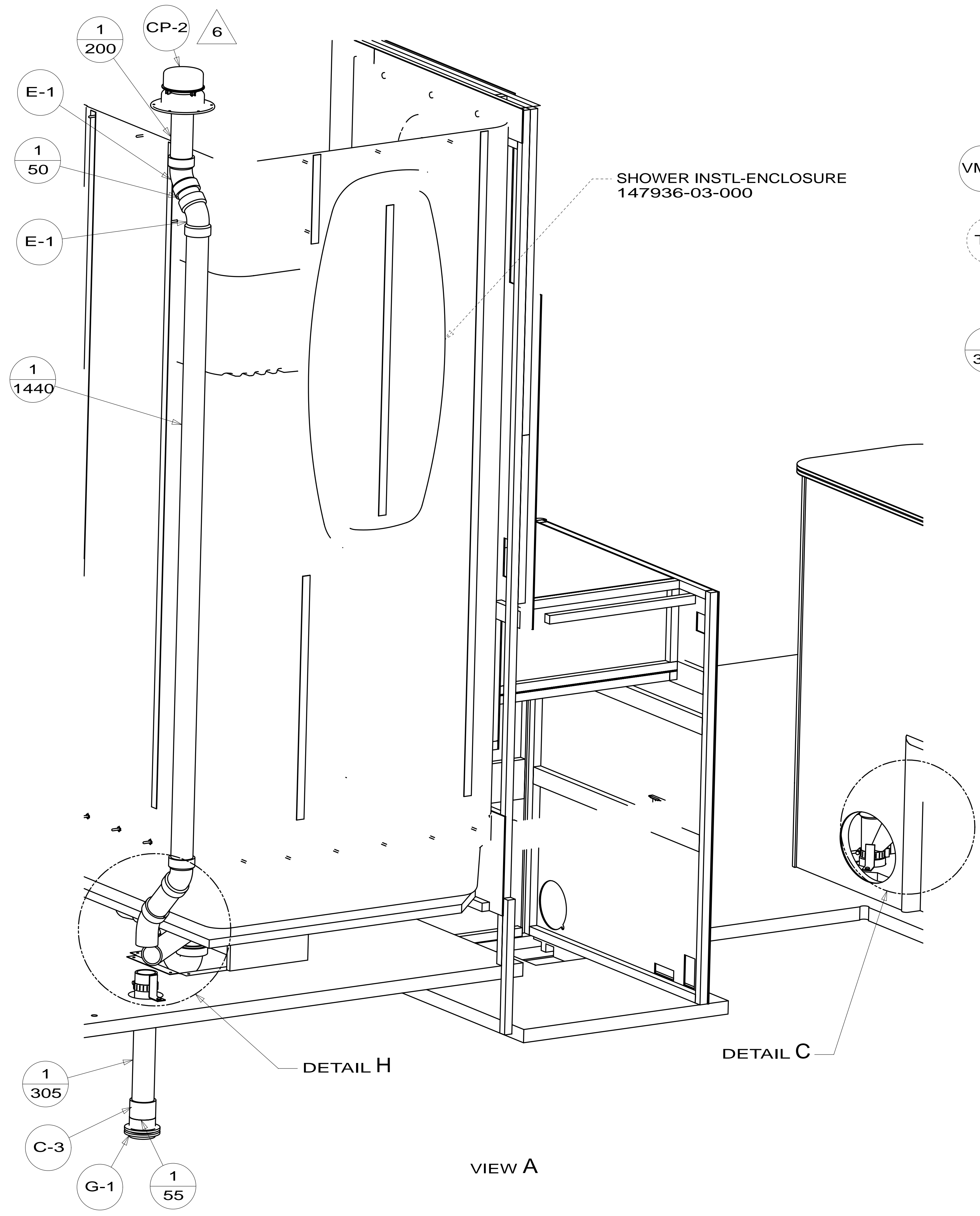

FIRST USED	13 231W	
TITLE:	DO NOT SCALE DRAWING	
SHEET 2	PART NO 179937	REV
		29-Apr-2013

* 179937 * A

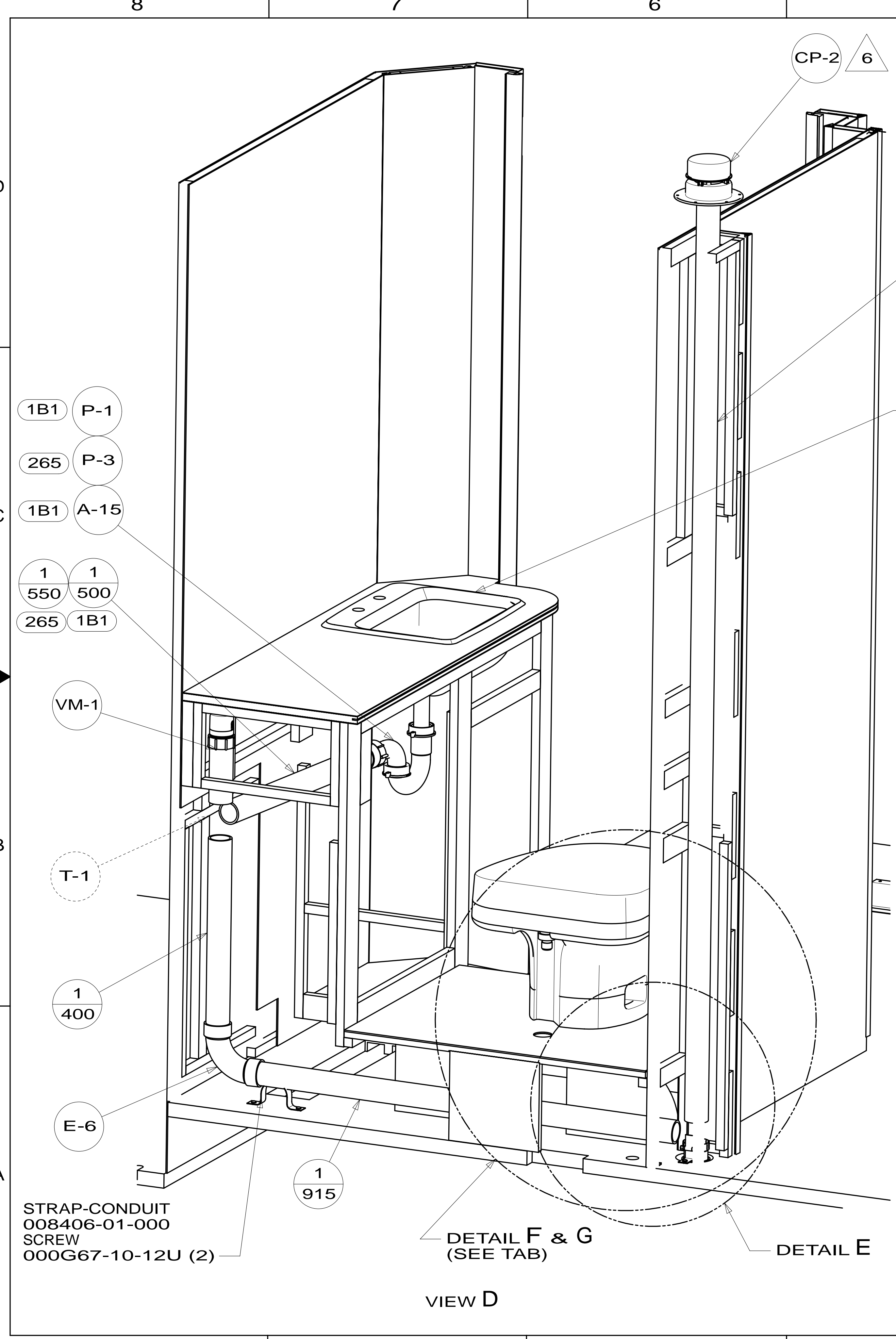

FLANGE-CLOSET
151541-01-000

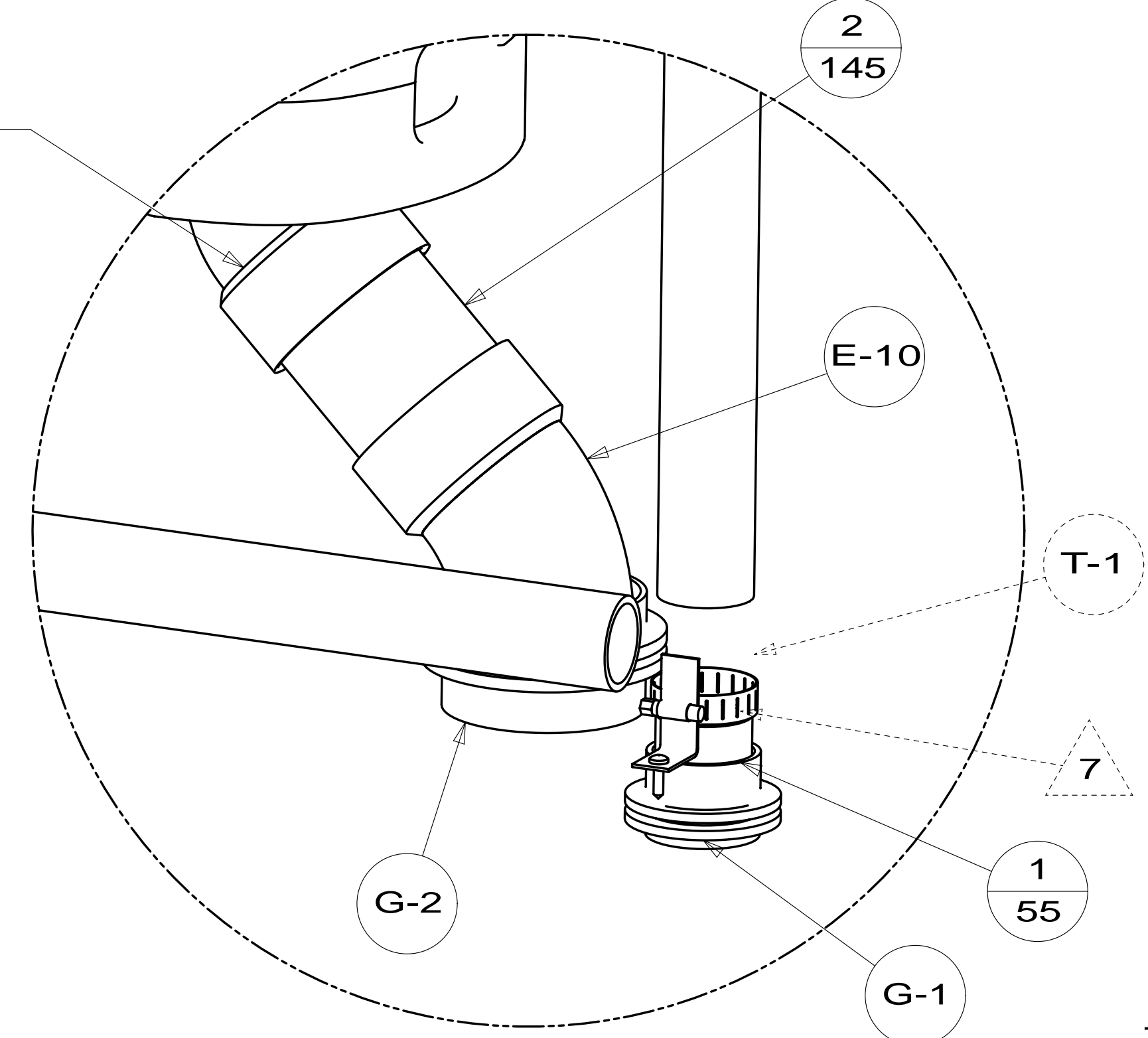

SINK
096927-01-CHT
SEAL
091255-02-000 (A/R)

SPRAYER BRACKET

TOILET
160815-04-CHT 43E
SCREW
087721-01-000(6)

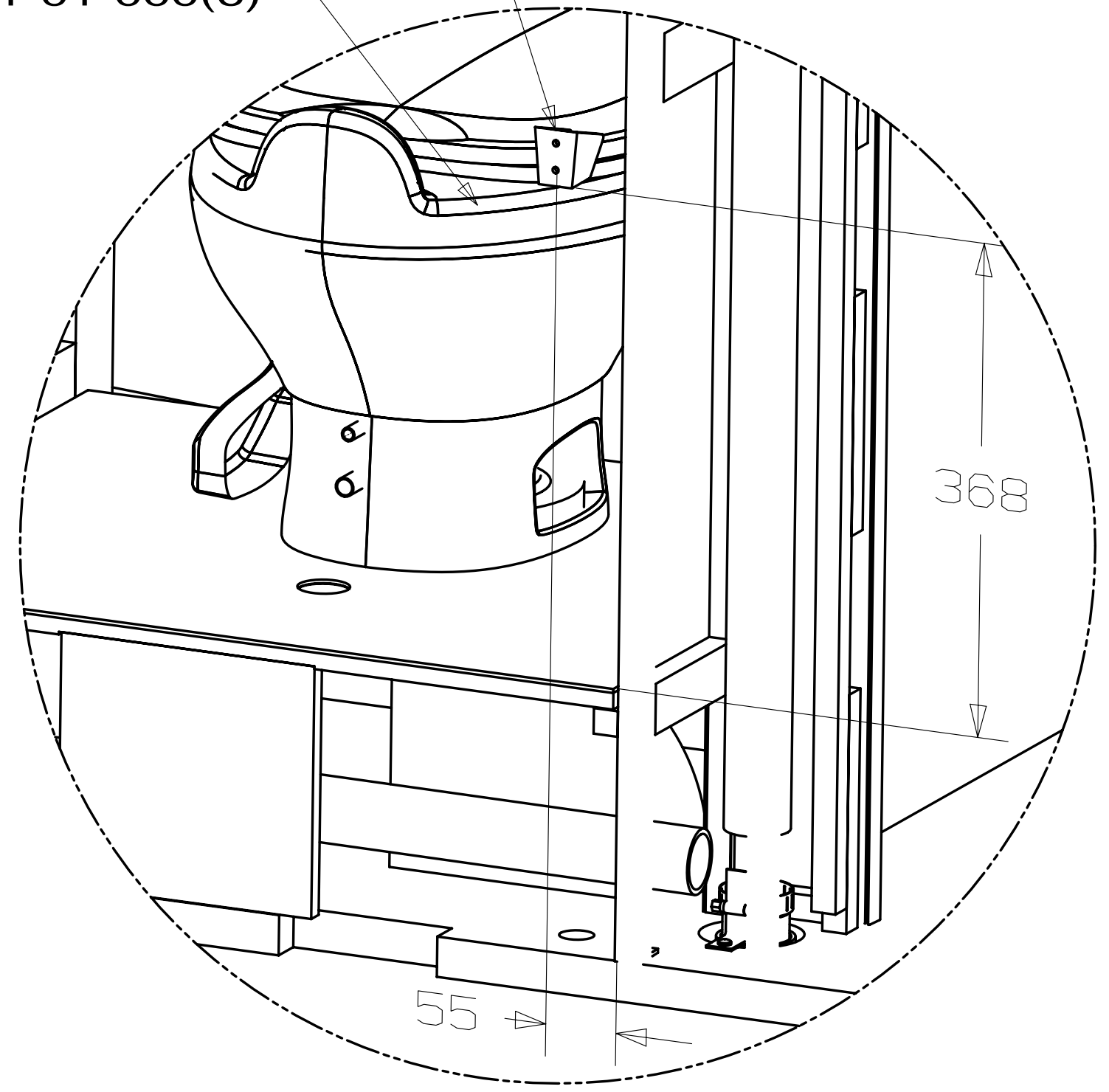

TOILET
147421-05-CHT
SCREW
087721-01-000(6)

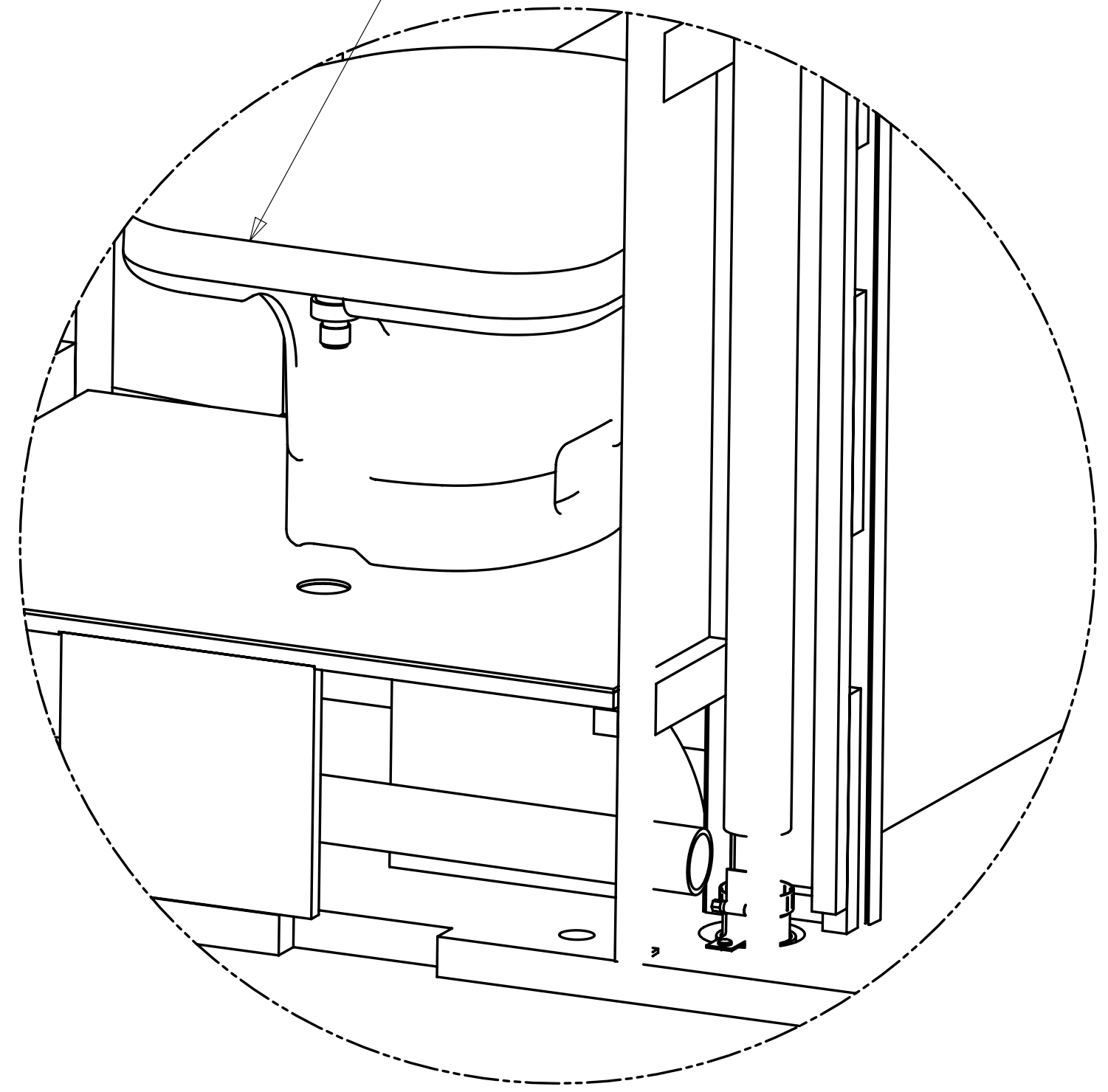

STRAP-CONDUIT
008406-01-000
SCREW
000G67-10-12U (2)

DETAIL F & G
(SEE TAB)

DETAIL E

VIEW D

FIRST USED	13 231W	
DO NOT SCALE DRAWING		
TITLE: DRAINAGE SYSTEM INSTL		
SHEET 3	PART NO 179937	REV
		29-Apr-2013

*179937 *A

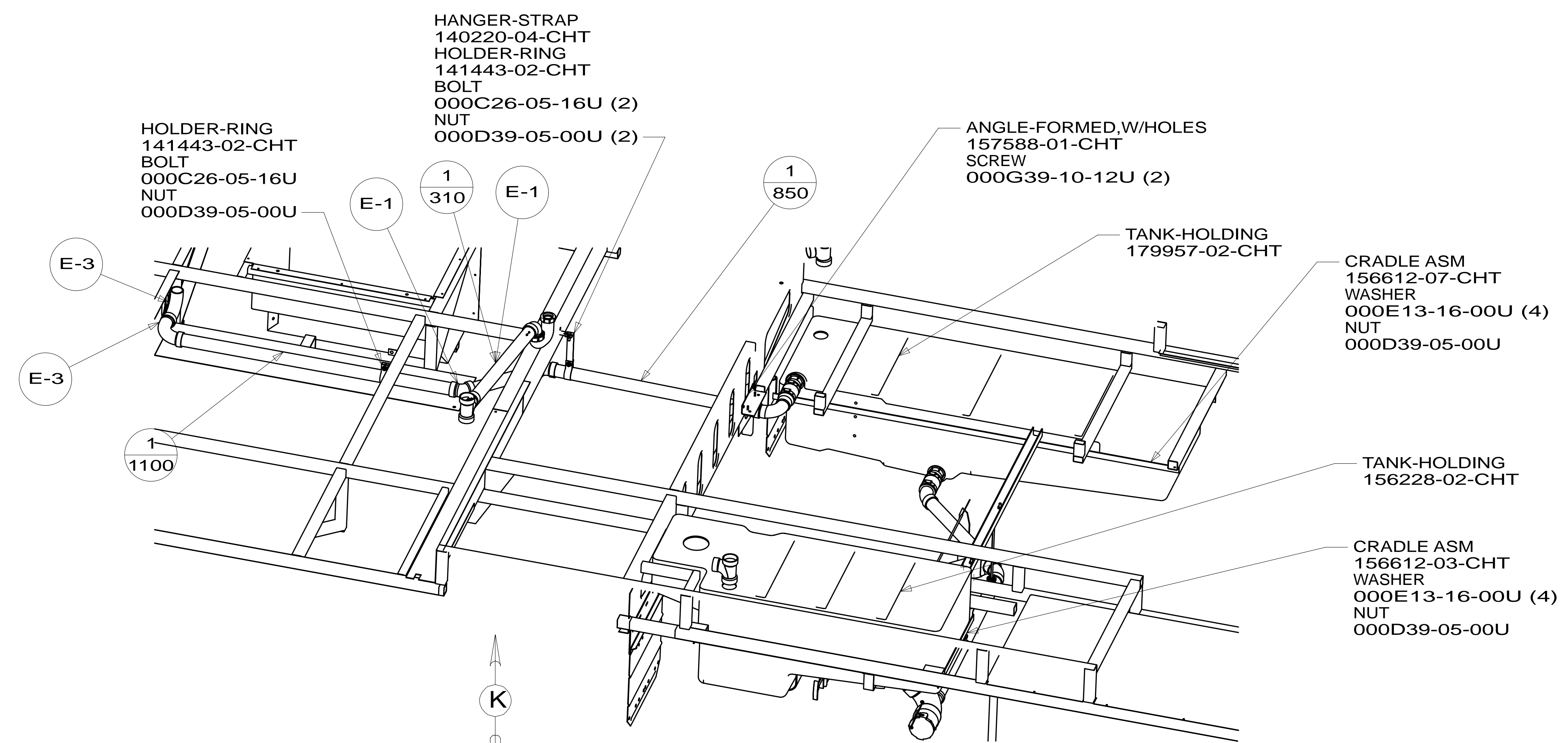

VIEW J
(SHOWING ONLY TANKS AND DRAINS)

FIRST USED	13 231W		
DO NOT SCALE DRAWING			
TITLE:	DRAINAGE SYSTEM INSTL		
SHEET 4	PART NO	179937	REV
		1	29-Apr-2013

* 179937 * A

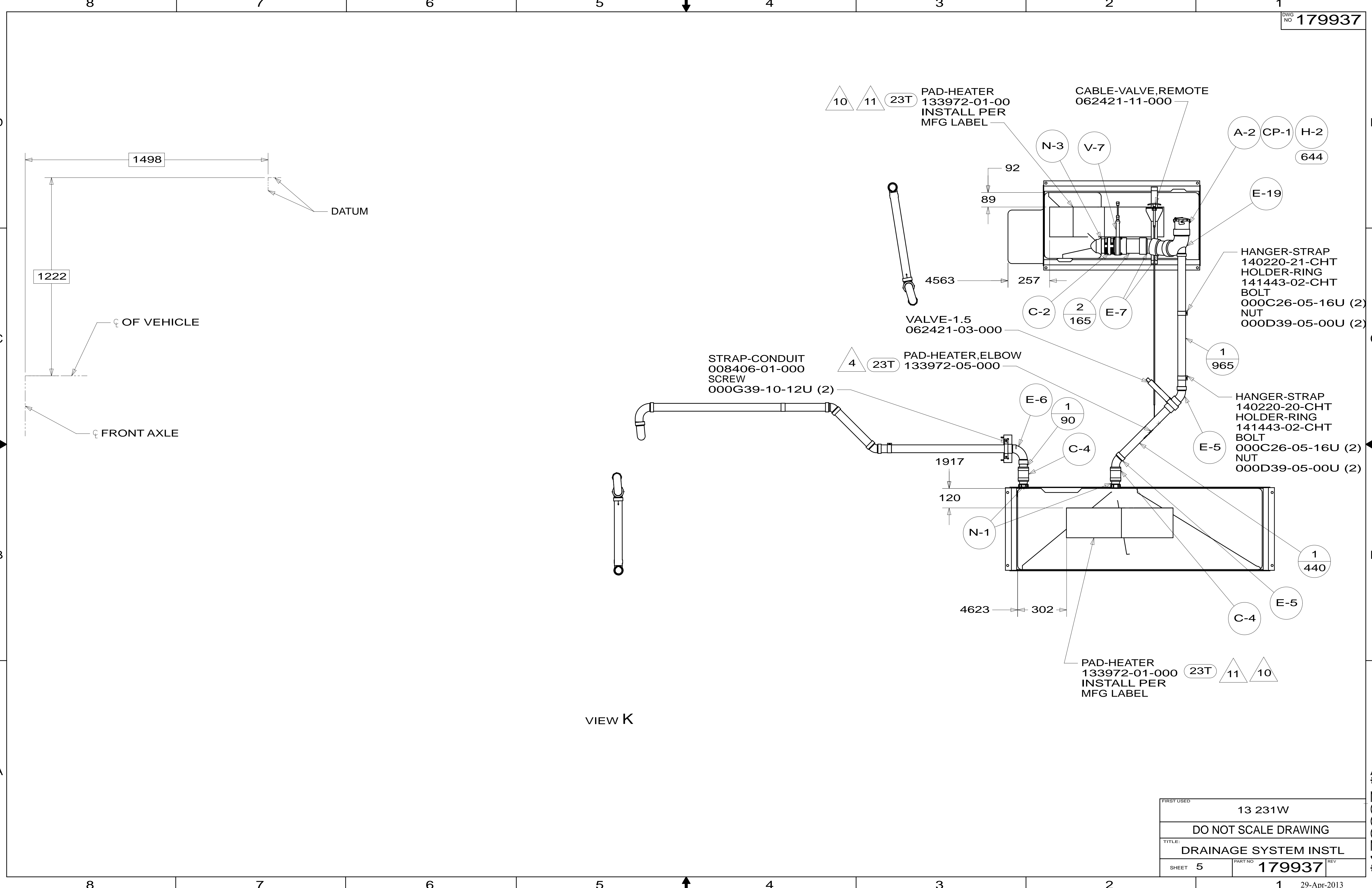

VIEW K

FIRST USED	13 231W		
TITLE:	DO NOT SCALE DRAWING		
TITLE:	DRAINAGE SYSTEM INSTL		
SHEET 5	PART NO	179937	REV
		1	29-Apr-2013

* 179937 * A

DWG NO	VIEW	MODEL
180669-01	E,H,K	231W
180669-02	F,J,L	231WP

RELEASE	REV DATE	DWG NO	180669
REV ZONE	REVISION RECORD	DATE	DFTR-ORIG

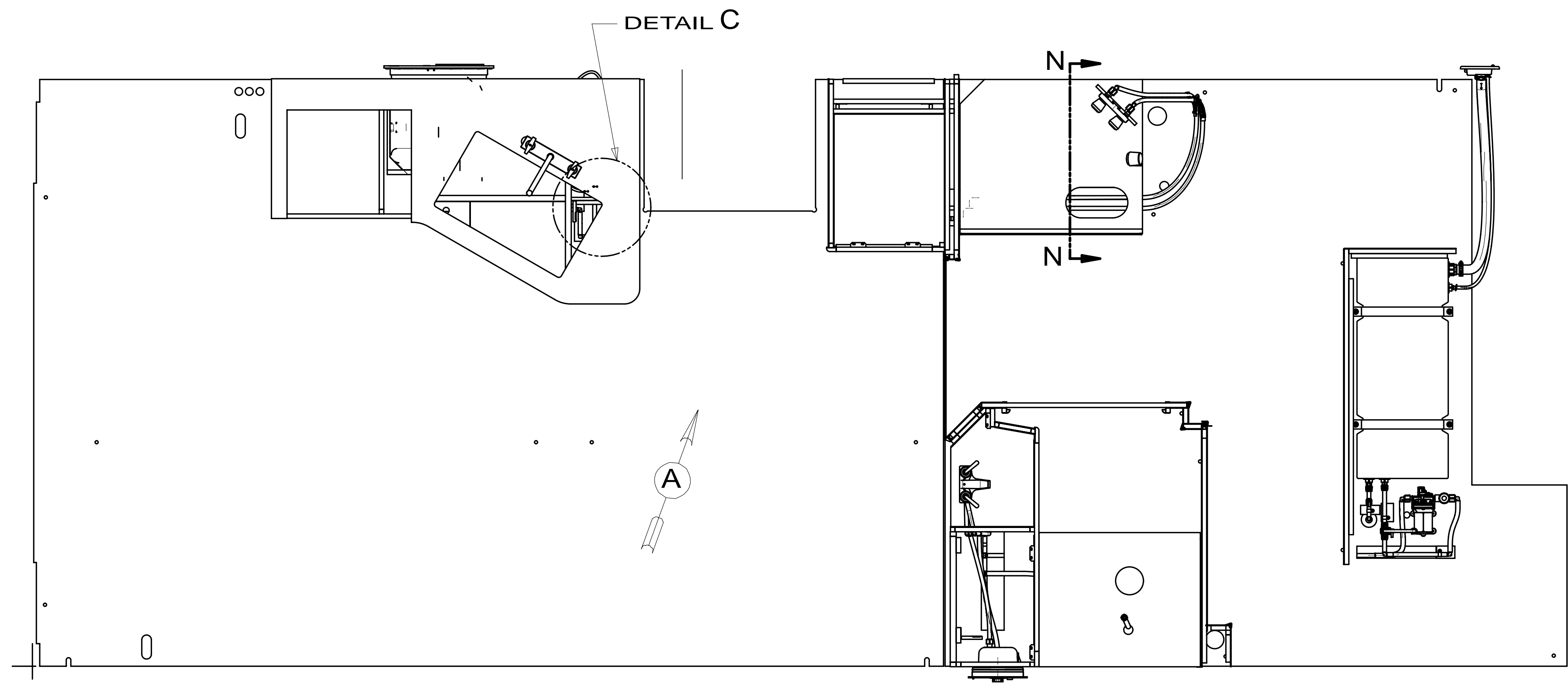

- 64R EXTERIOR WASH STATION
- 53Z WTR HTR-6GAL/110/LP/MTR/AUTO
- 1J4 EXT WASH STATION-WITHOUT
- 53F WATER HEATER-ELEC IGNITION

- 9. INSTALL BYPASS PLUG FOR SYSTEM TESTING AND SHIPPING.
- 8. ALL CRIMP FITTINGS TO 1/2" PEX TUBING REQUIRE 1/2" CLAMP 140171-03-000.
- 7. ALL CRIMP FITTINGS TO 5/8" PEX TUBING REQUIRE 5/8" CLAMP 140171-04-000.
- 6. LABEL HOT AND COLD SUPPLY TUBES AND TAPE FITTING TO TUBE BEFORE CABINET SET TO PREVENT MOVEMENT.
- 5. ADD PIPE WRAP (LADDER SCRAP 110157-02-000) INSULATION.
- 4. ADD TEFLON TAPE 010405-02-000.
- 3. ALL TUBING TO BE SECURED AT 1200 INTERVALS MAXIMUM WITH CLAMP 010495-01-000 AND SCREW 000G67-10-12U OR EQUIVALENT.
- 2. TUBING TO BE INSTALLED WITH SUFFICIENT SLOPE TO PROVIDE DRAINAGE TO NEAREST VALVE.
- 1. PLASTIC FITTINGS TO BE SEALED WITH SEALANT 084456-01-000.

		COPYRIGHT 2013 WINNEBAGO INDUSTRIES, INC.	
DFTR	ORIG. DATE	ALL DIMENSIONS ARE IN MILLIMETERS	
CHKR			
P.E.			
M.E.	FIRST USED		
DSNR		13 231W	
UNSPECIFIED TOLERANCES ARE:		MATERIAL:	
WHOLE DIM (X)	: 3		
ONE-PLACE (X.X)	: 1.5		
TWO-PLACE (X.XX)	: 0.50		
ANGLE	: 1°		
THIRD ANGLE PROJECTION			
DO NOT SCALE DRAWING		REFER TO ES0018 FOR FASTENER TIGHTENING GUIDELINES	
TITLE: WATER SYSTEM INSTL			
SHEET 1 OF 4	PART NO	180669	REV
REF:	1	20-Aug-2013	

FOR WATER CALLOUTS SEE DWG NO 116230-01-000

A * 180669

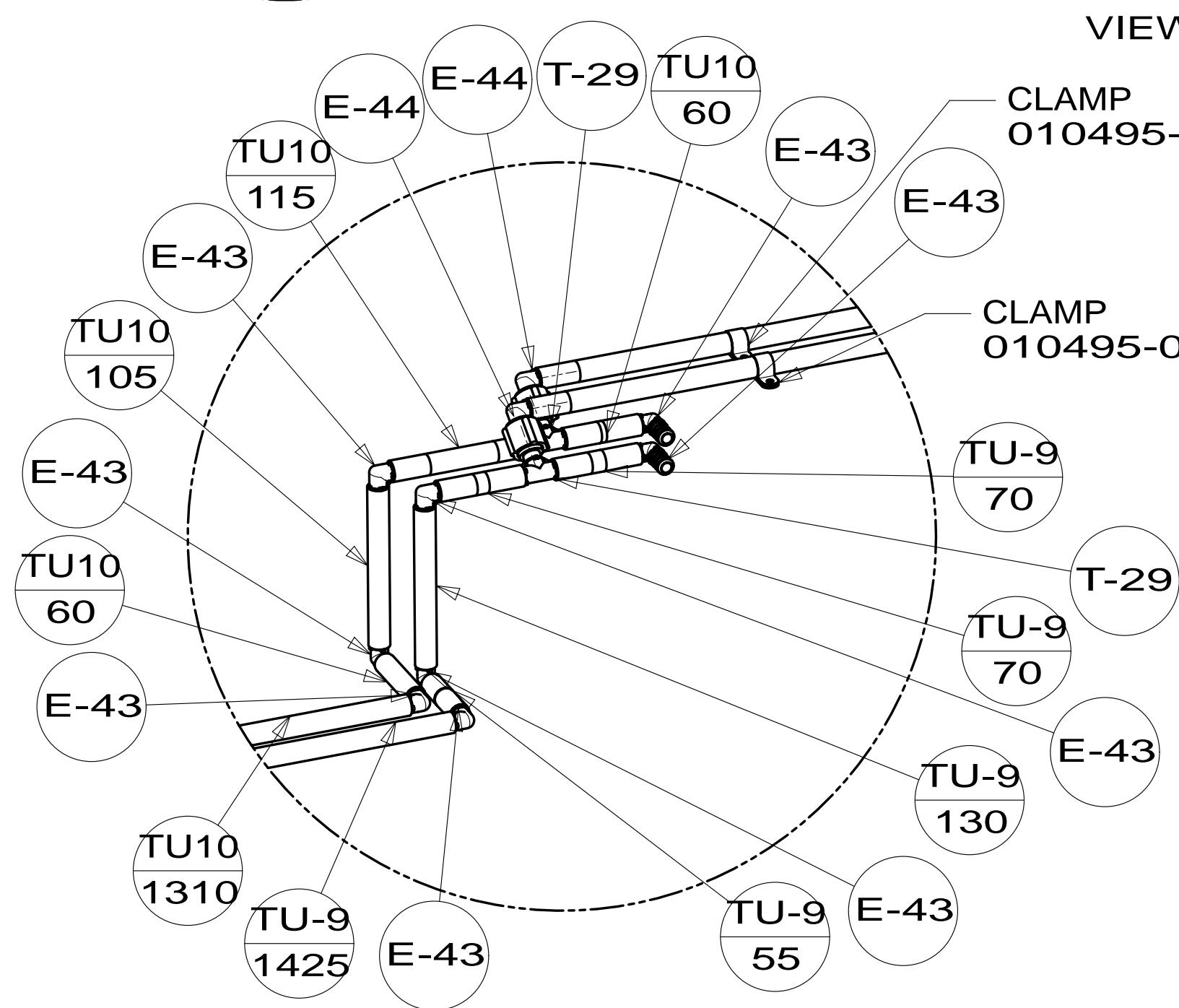
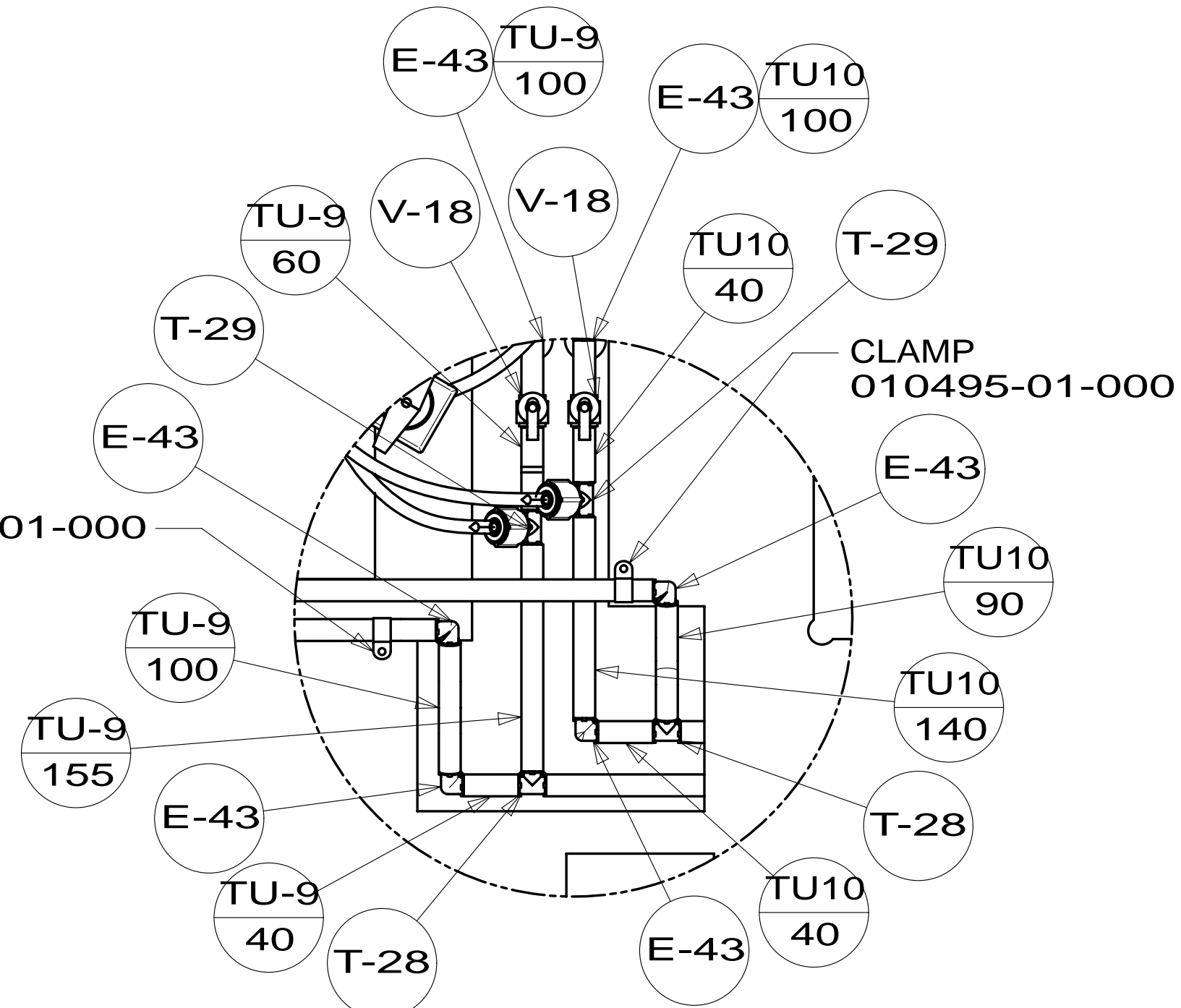
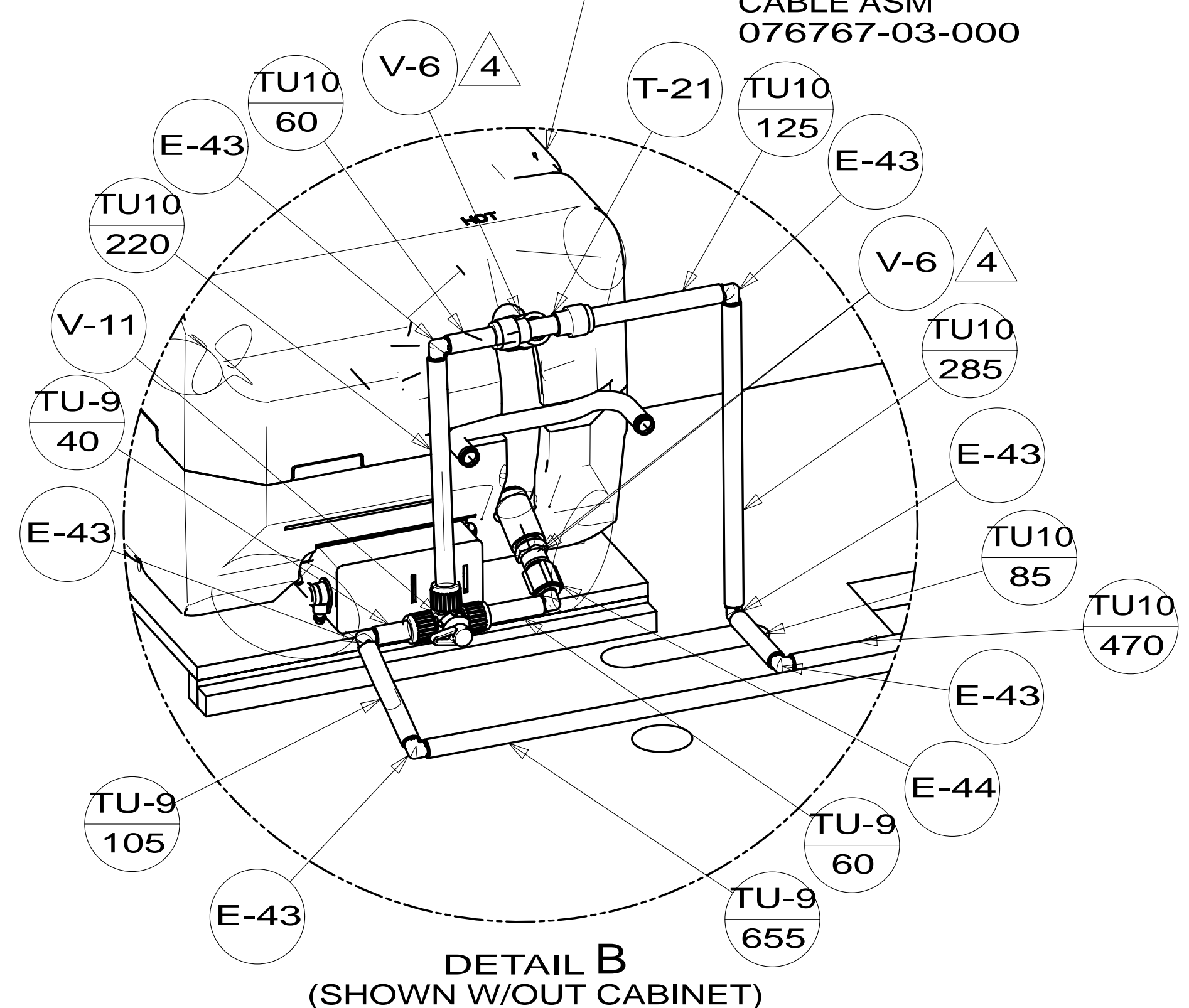
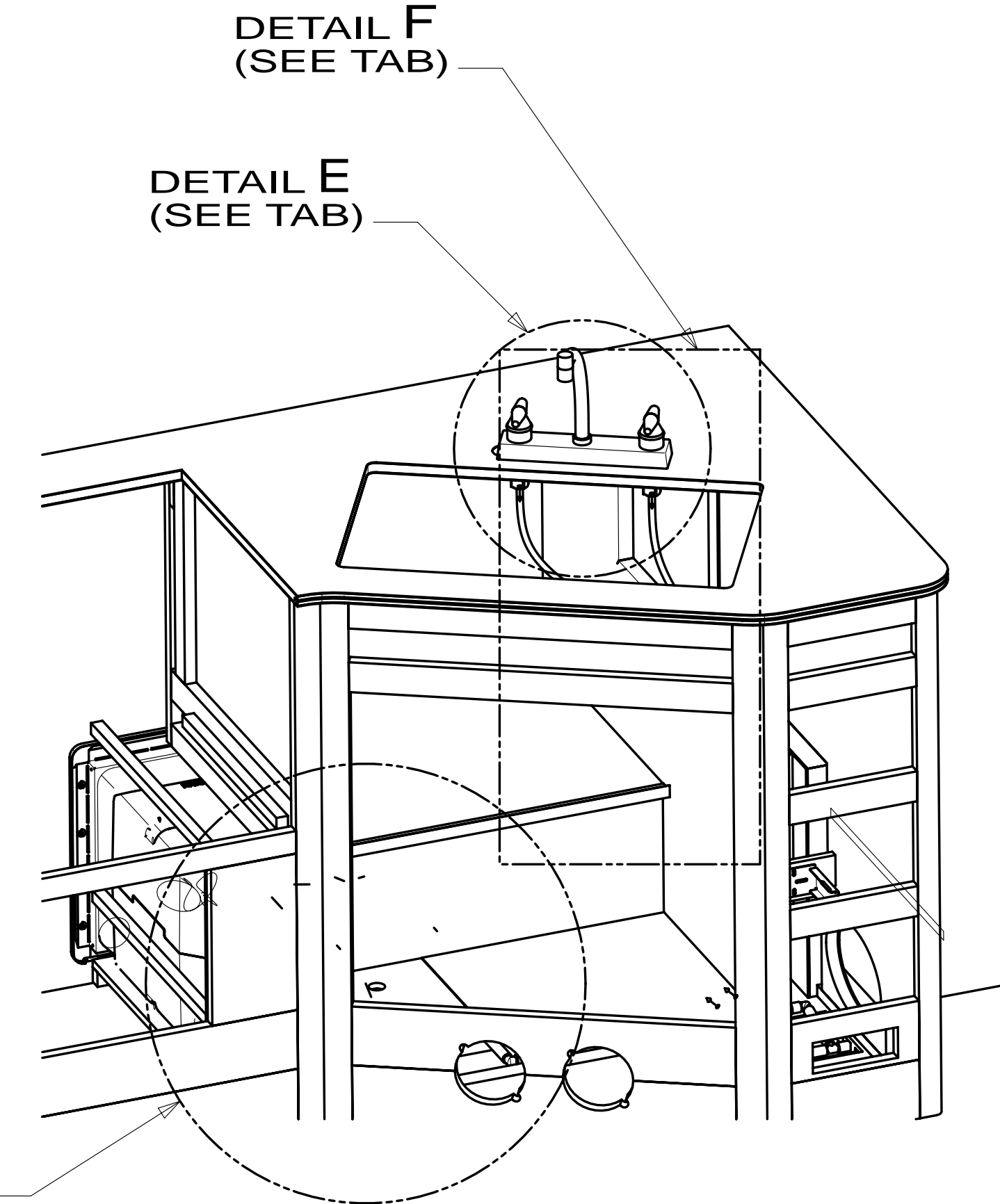
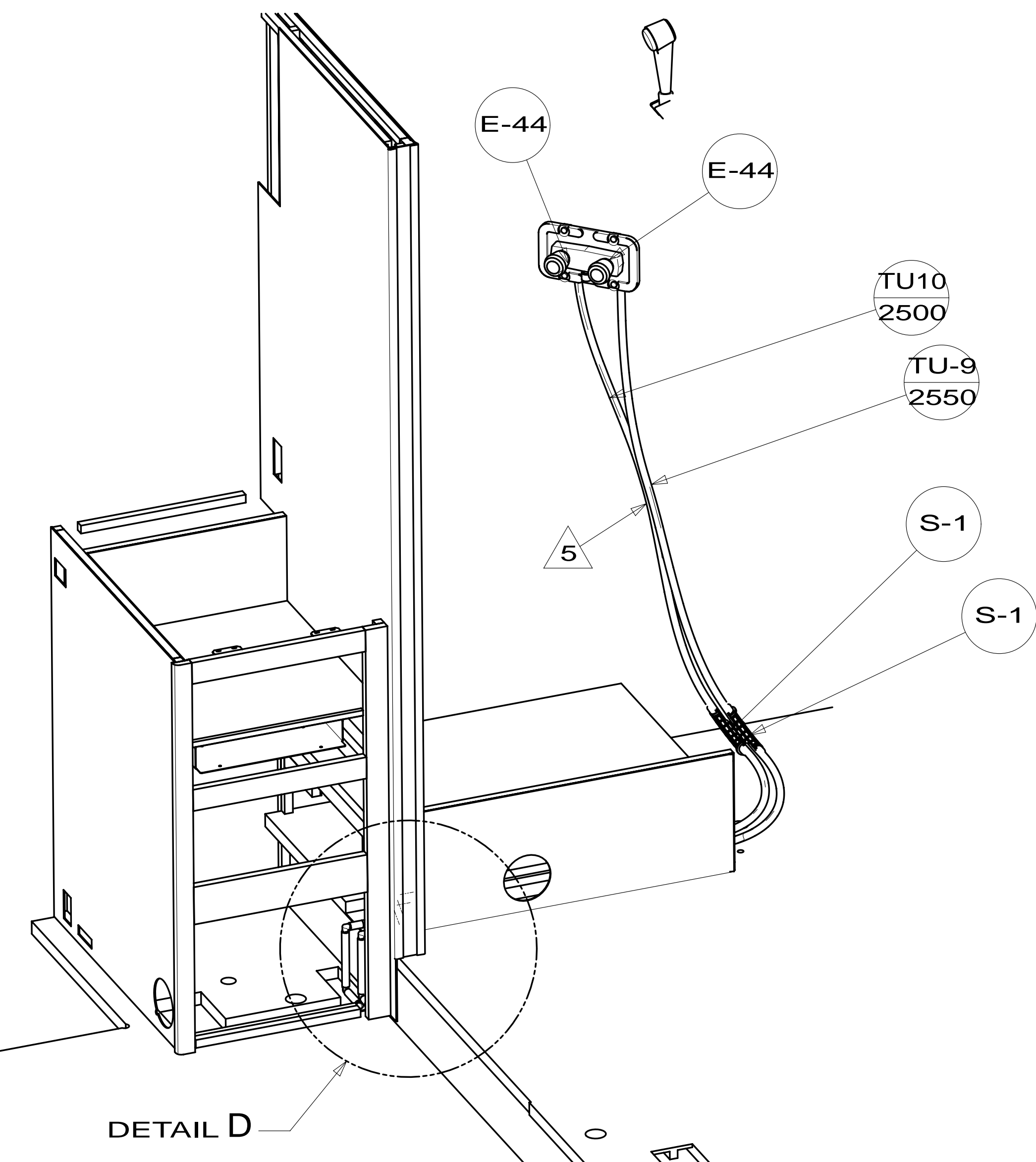
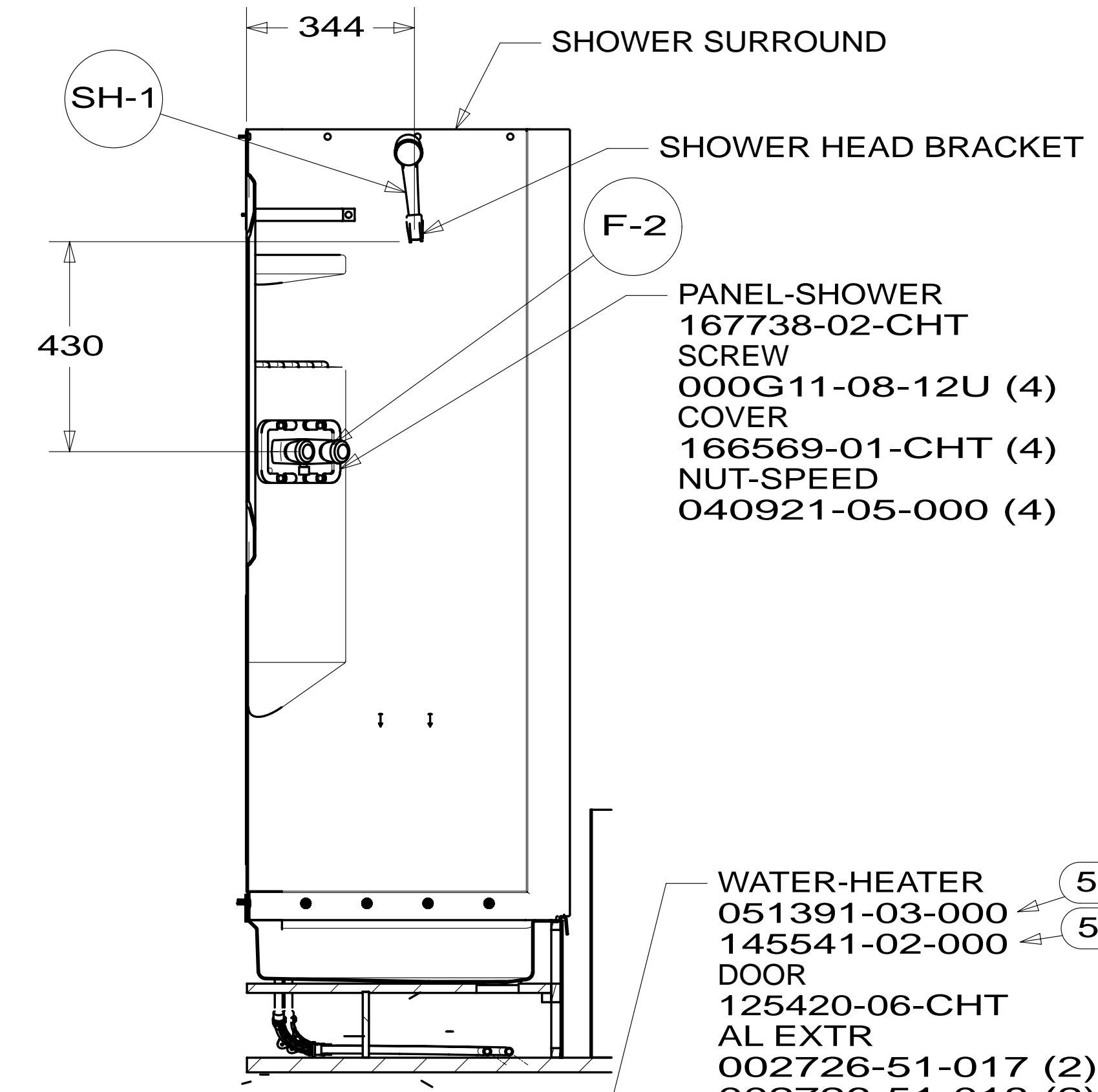

FIRST USED	13 231W	
TITLE:	DO NOT SCALE DRAWING	
SHEET	2	PART NO 180669 REV
20-Aug-2013		

* 180669

FAUCET-GALLEY, SGL CONTROL
149164-01-CHT

FAUCET-GALLEY, DUAL LEVERS
140117-03-CHT

DETAIL H & J
(SEE TAB)

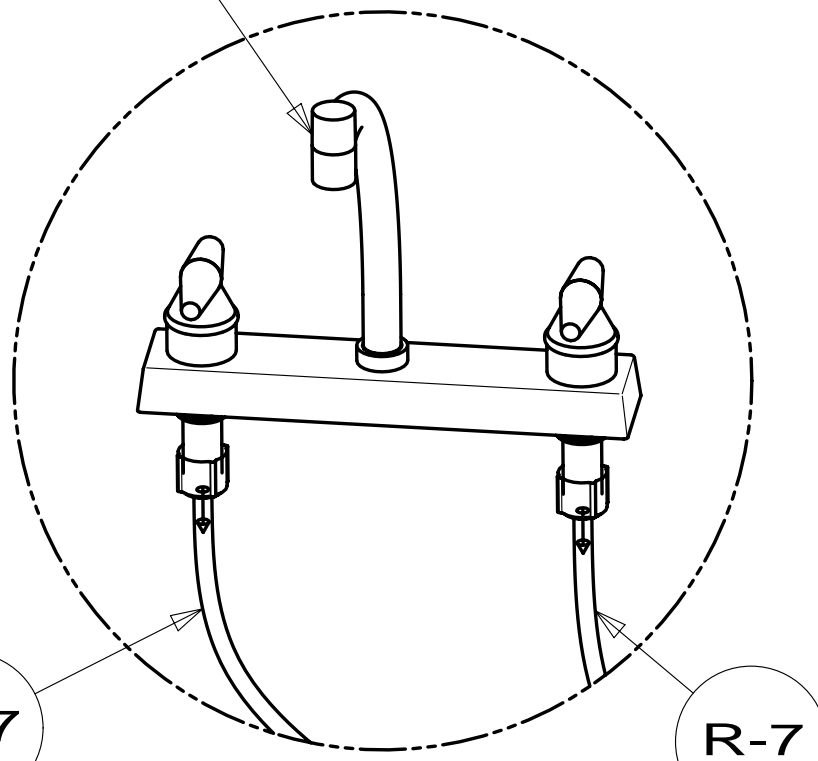
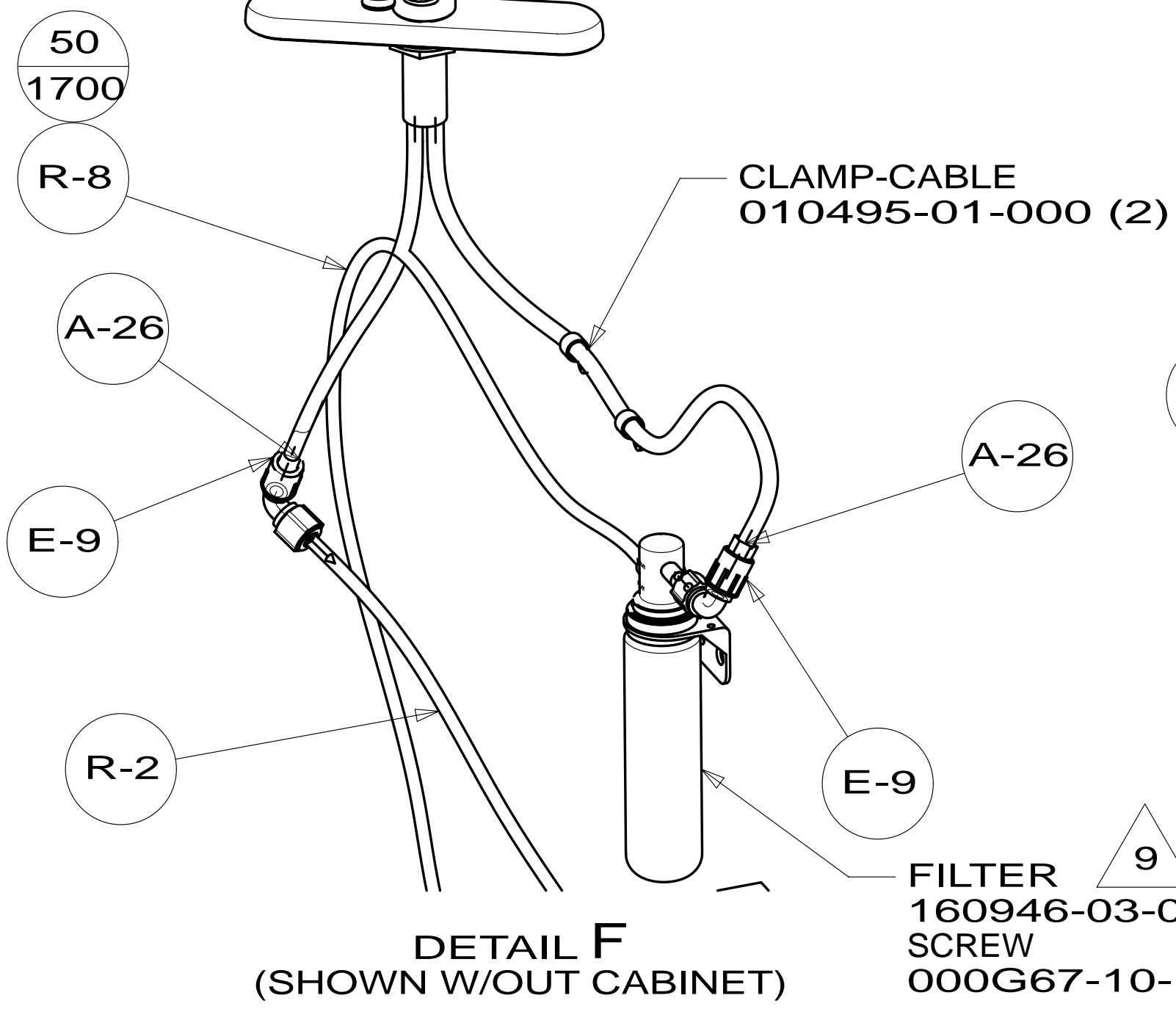

DETAIL E
(SHOWN W/OUT CABINET)

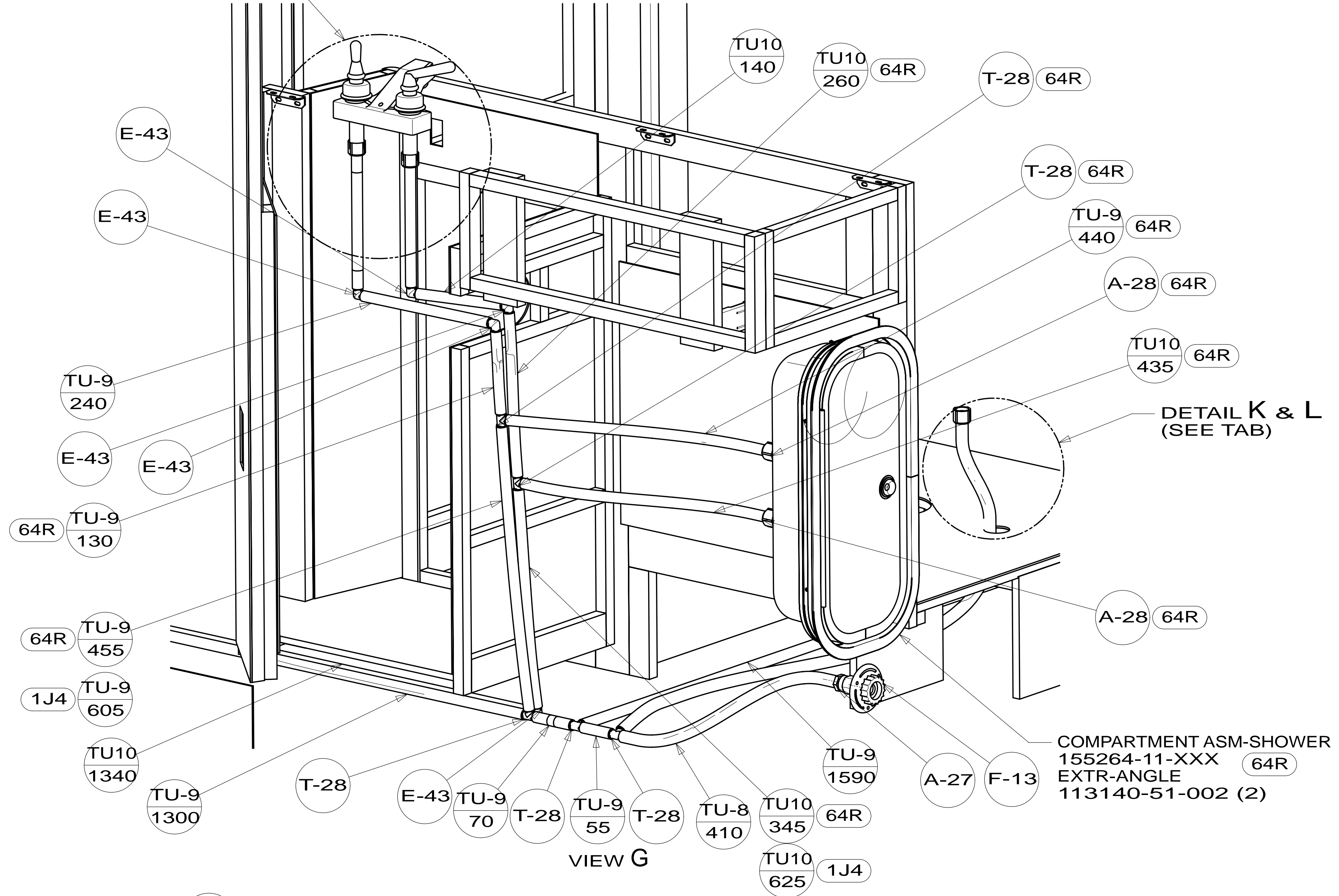

VIEW G

FAUCET-LAV, DUAL CONTROL
148886-03-CHT

FAUCET-LAV
165730-01-CHT

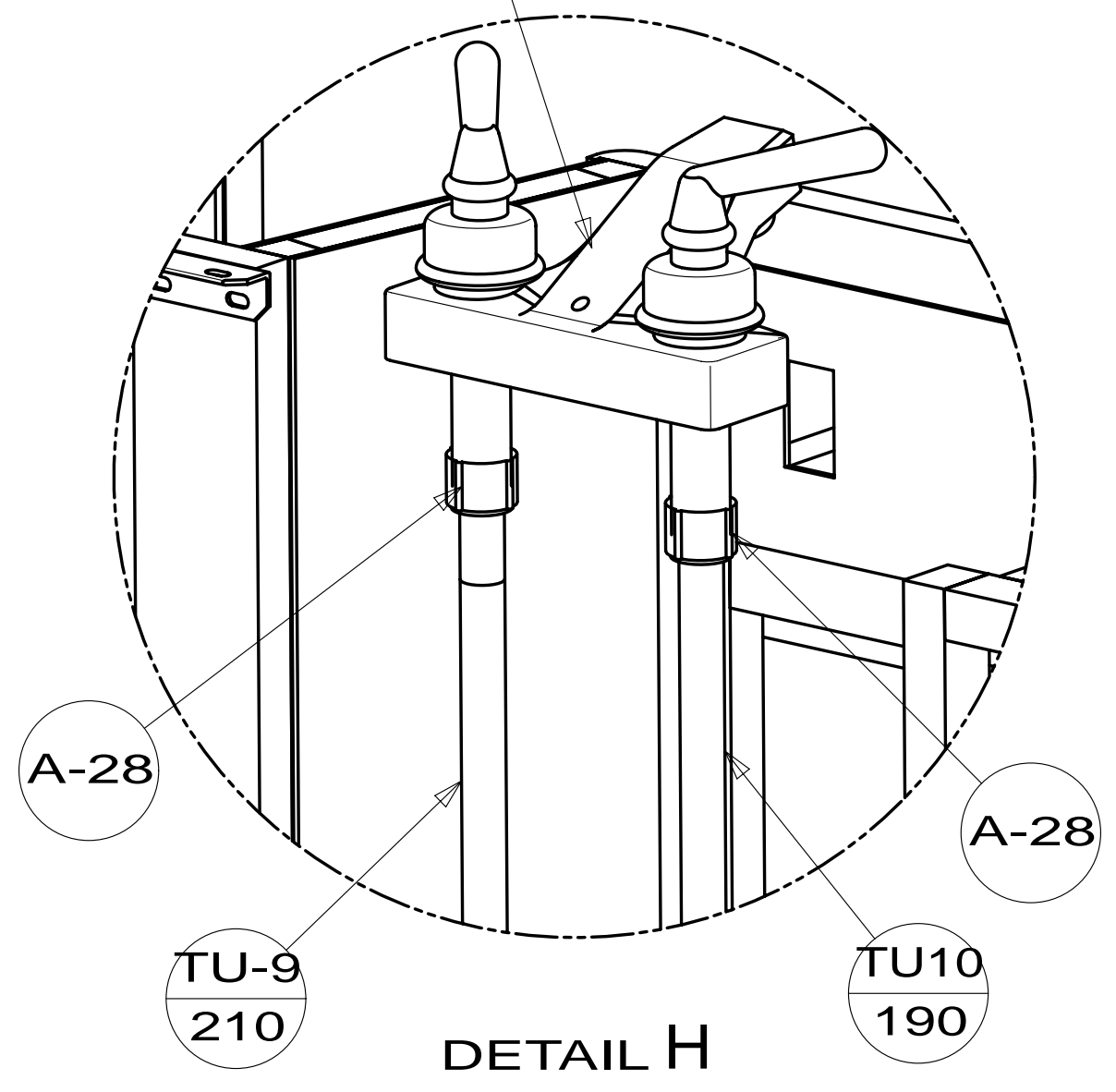

DETAIL H

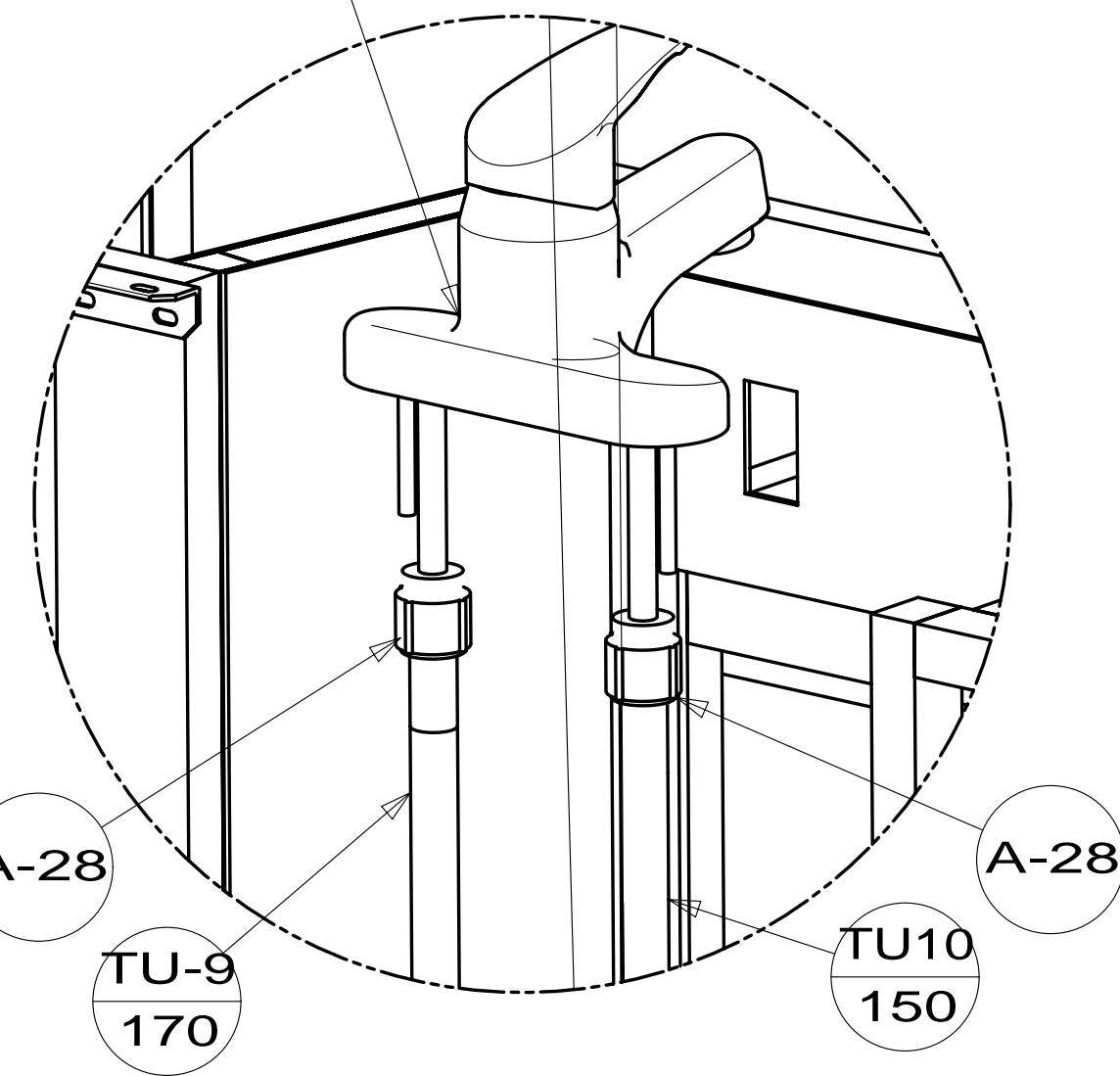

DETAIL J

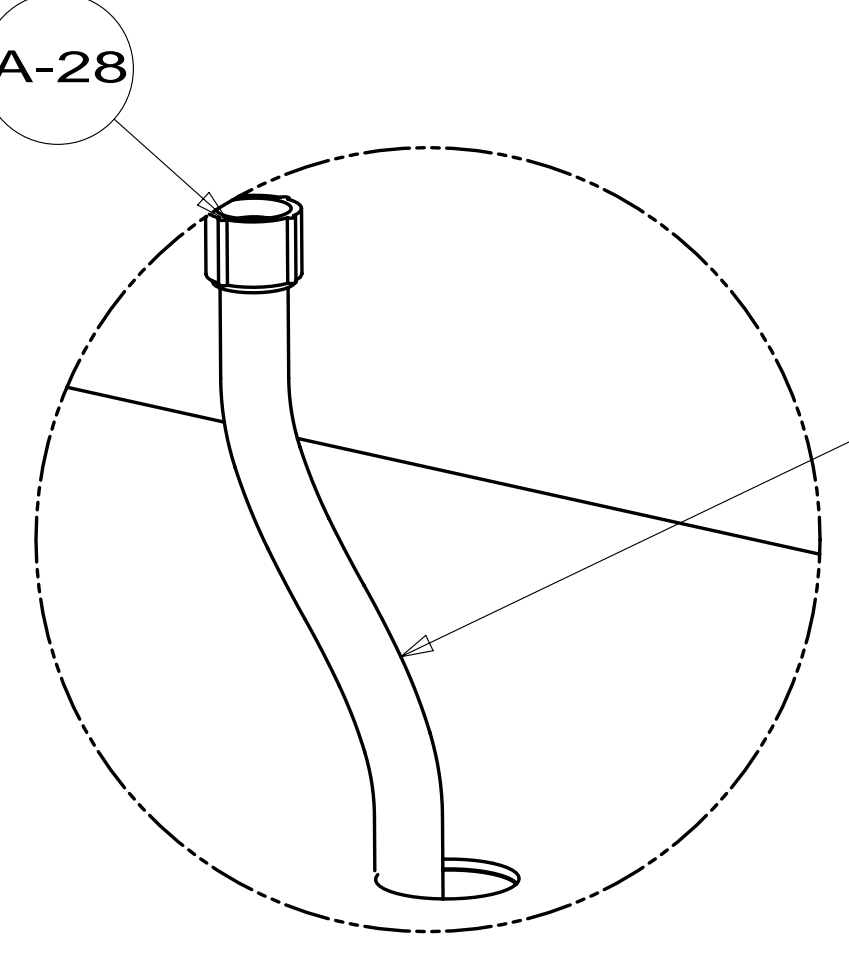

DETAIL K

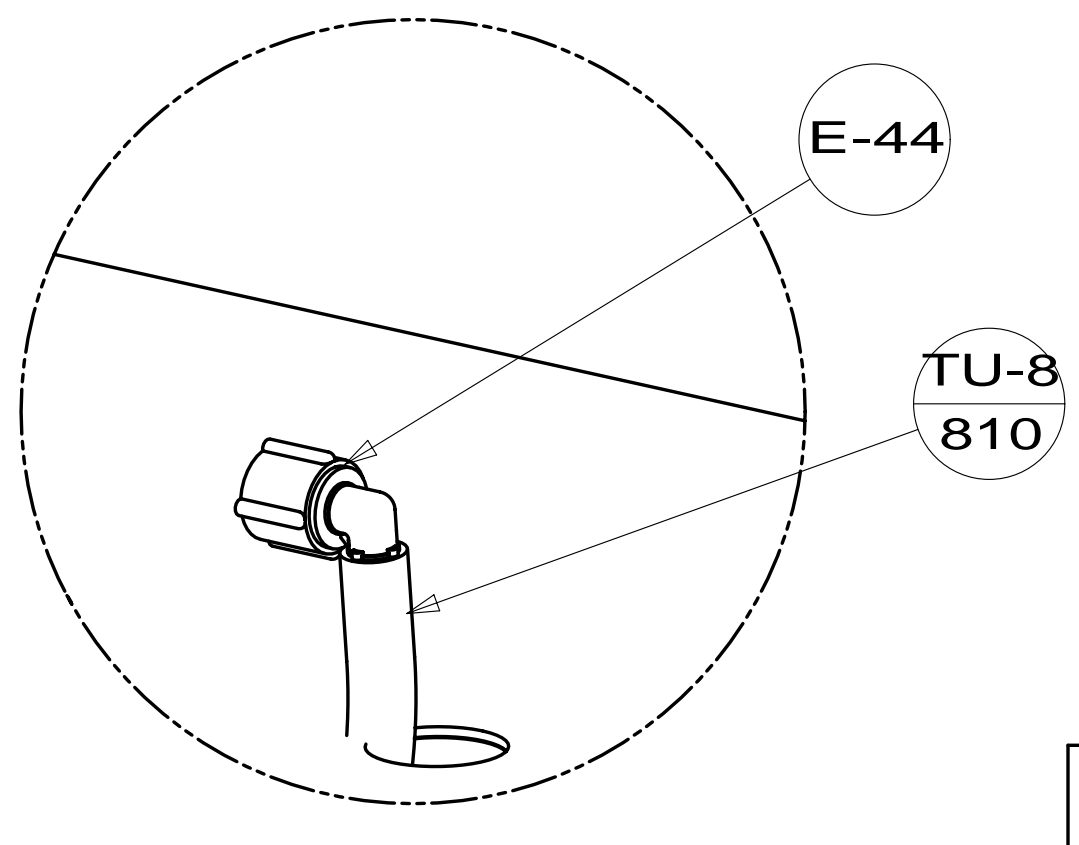

DETAIL L

FIRST USED	13 231W	
TITLE:	DO NOT SCALE DRAWING	
SHEET 3	PART NO	180669
	REV	
20-Aug-2013		

* 180669

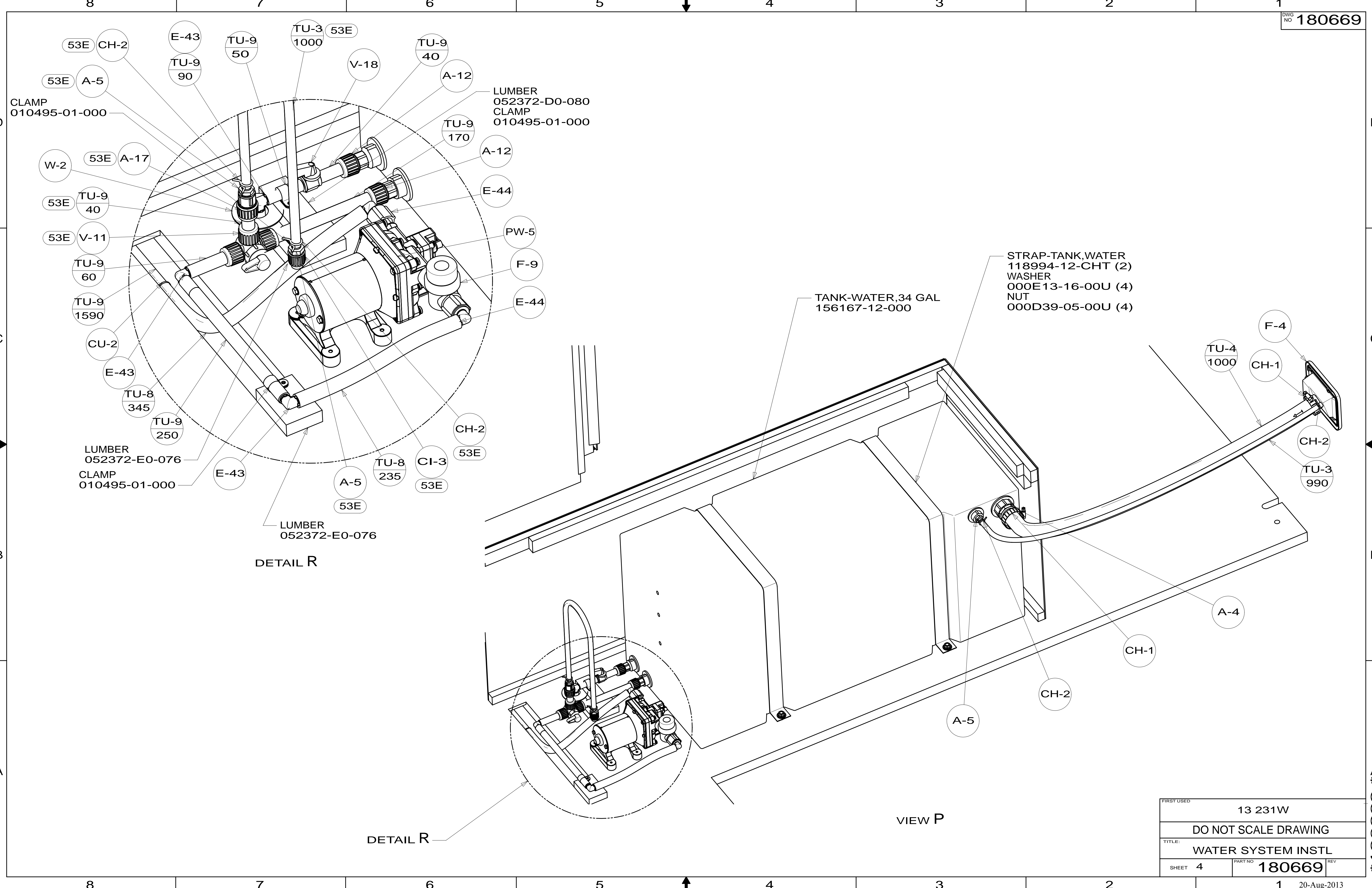

CLAMP
010495-01-000

LUMBER
052372-D0-080
CLAMP
010495-01-000

TANK-WATER,34 GAL
156167-12-000

STRAP-TANK,WATER
118994-12-CHT (2)
WASHER
000E13-16-00U (4)
NUT
000D39-05-00U (4)

LUMBER
052372-E0-076
CLAMP
010495-01-000

LUMBER
052372-E0-076

DETAIL R

VIEW P

DETAIL R

FIRST USED	13 231W		
TITLE:	DO NOT SCALE DRAWING		
SHEET 4	PART NO	180669	REV
			20-Aug-2013

* 180669