

DWG NO	-----	MODEL
181550-01	SECTION B-B	231J
181550-02	SECTION F-F	231JP

RELEASE	REV DATE	DWG NO	181550
REV ZONE	REVISION RECORD	DATE	DTR-ORIG

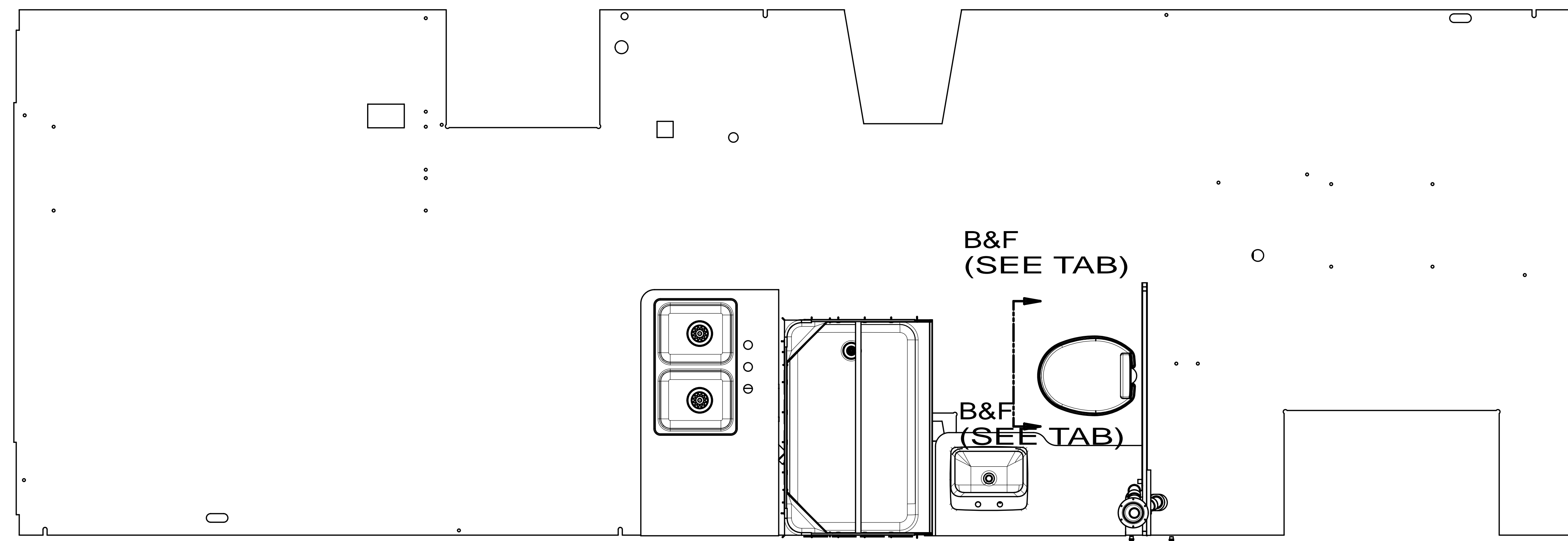

- NOTES:
1. SLOPE OF HORIZONTAL PIPING TO BE MINIMUM OF 3 PER 305 mm.
 2. SLOPE OF TRAP ARM MUST BE 6 PER 305 mm.
 3. ALL PIPE AND FITTINGS TO BE ASSEMBLED WITH SOLVENT 004020-01-000 (USA), 004020-02-000 (CAN)
 4. USE SMOOTH PLUMBERS PUTTY 167459-01-000 TO SEAL STRAINER (0.2 PER STRAINER).
 5. SEAL AROUND SHOWER WITH SILICONE.
 6. VENT PIPE MUST PROJECT 51 MIN AND 64 MAX ABOVE ROOF FOR PROPER FIT AND FUNCTION. ADD S-1 (116666-01-CHT SEAL-VENT PIPE) AROUND PIPE ON ROOF BEFORE VENT CAP IS INSTALLED.
 7. SECURE VENT PIPE TO FLOOR WITH CLAMP 062401-02-000 (2), SCREW 000G67-10-12U (2), BRACKET 136878-01-CHT (2).
 8. SECURE DRAINAGE PIPES TO CABINET USING WIRE TIE 108046-02-000, AND SCREW 000G67-10-12U AT INTERVALS OF NOT OF NOT MORE THAN 4 FEET APART.
 9. SEE DRAWING 061607 FOR INSTALLATION OF GROMMETS.
 10. WATERLESS P-TRAP MUST BE INSTALLED WITH THE RIBS POINTING DOWN
 11. PREP THE SURFACE PER MANUFACTURERS INSTRUCTIONS BEFORE APPLYING THE HEATING PAD.
 12. SEE WIRING INSTL-BODY FOR ELECTRICAL CONNECTION.

- 43E TOILET PROCELAIN-ROUND
- 464 TOILET
- 1B1 CODES/STANDARDS USA
- 265 CODES/STANDARDS-CSA/CMVSS
- 23T DRAINAGE SYSTEM-HEATED
- 644 GREAT ALASKAN RENTALS

FOR DRAINAGE CALLOUTS SEE DWG NO 116229-01-000

		COPYRIGHT 2012 WINNEBAGO INDUSTRIES, INC.	
DTR	ORIG. DATE	ALL DIMENSIONS ARE IN MILLIMETERS	
CHKR			
P.E.			
M.E.	FIRST USED	13 231J	
DSNR			
UNSPECIFIED TOLERANCES ARE:		MATERIAL:	
WHOLE DIM (X)	: 3		
ONE-PLACE (X.X)	: 1.5		
TWO-PLACE (X.XX)	: 0.50		
ANGLE	: 1°		
THIRD ANGLE PROJECTION			
DO NOT SCALE DRAWING	REFER TO ES0018 FOR FASTENER TIGHTENING GUIDELINES		
TITLE: DRAINAGE SYSTEM INSTL			
SHEET 1 OF 3	PART NO 181550	REV	
REF:	1	13-Jun-2012	

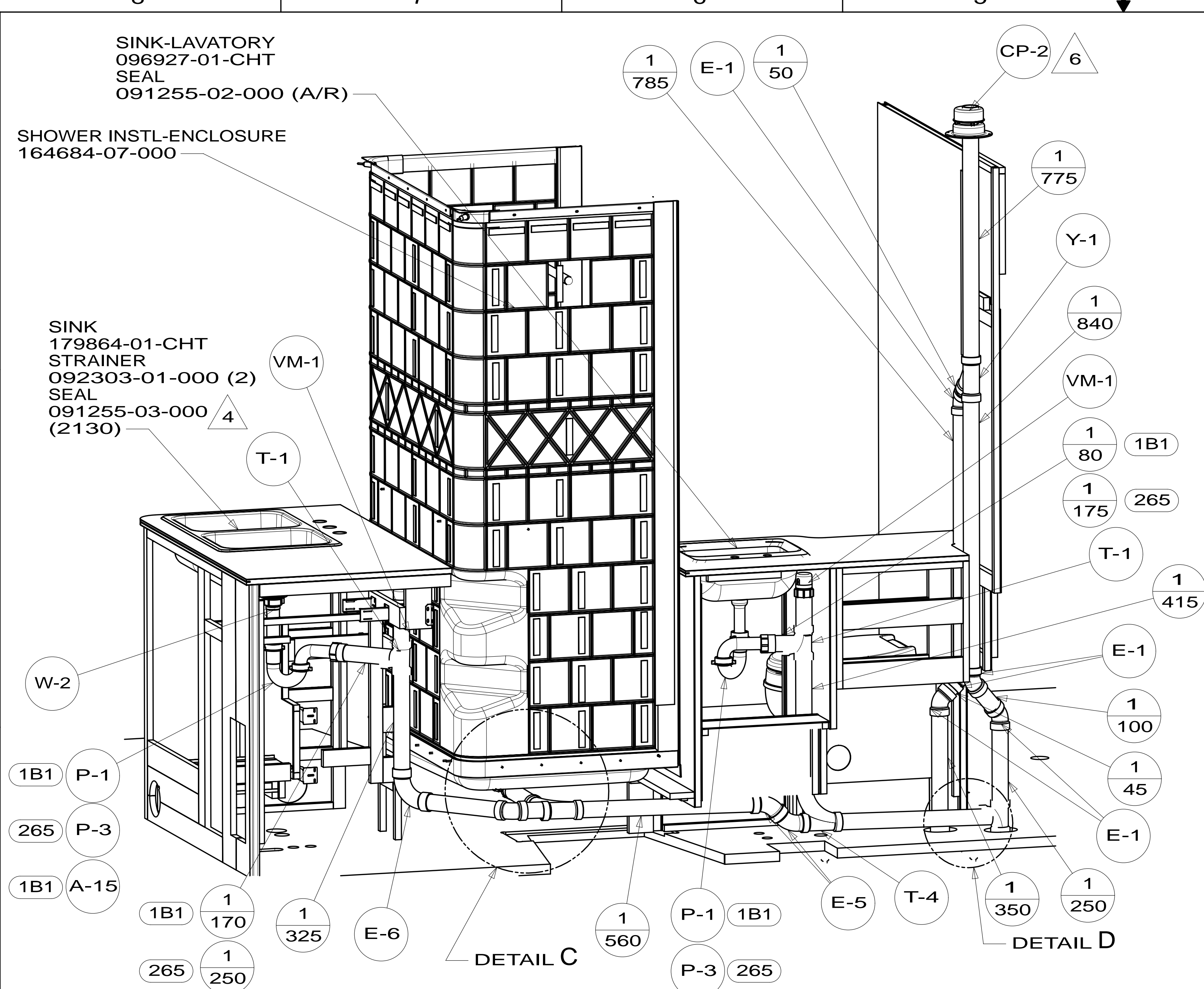

VIEW A

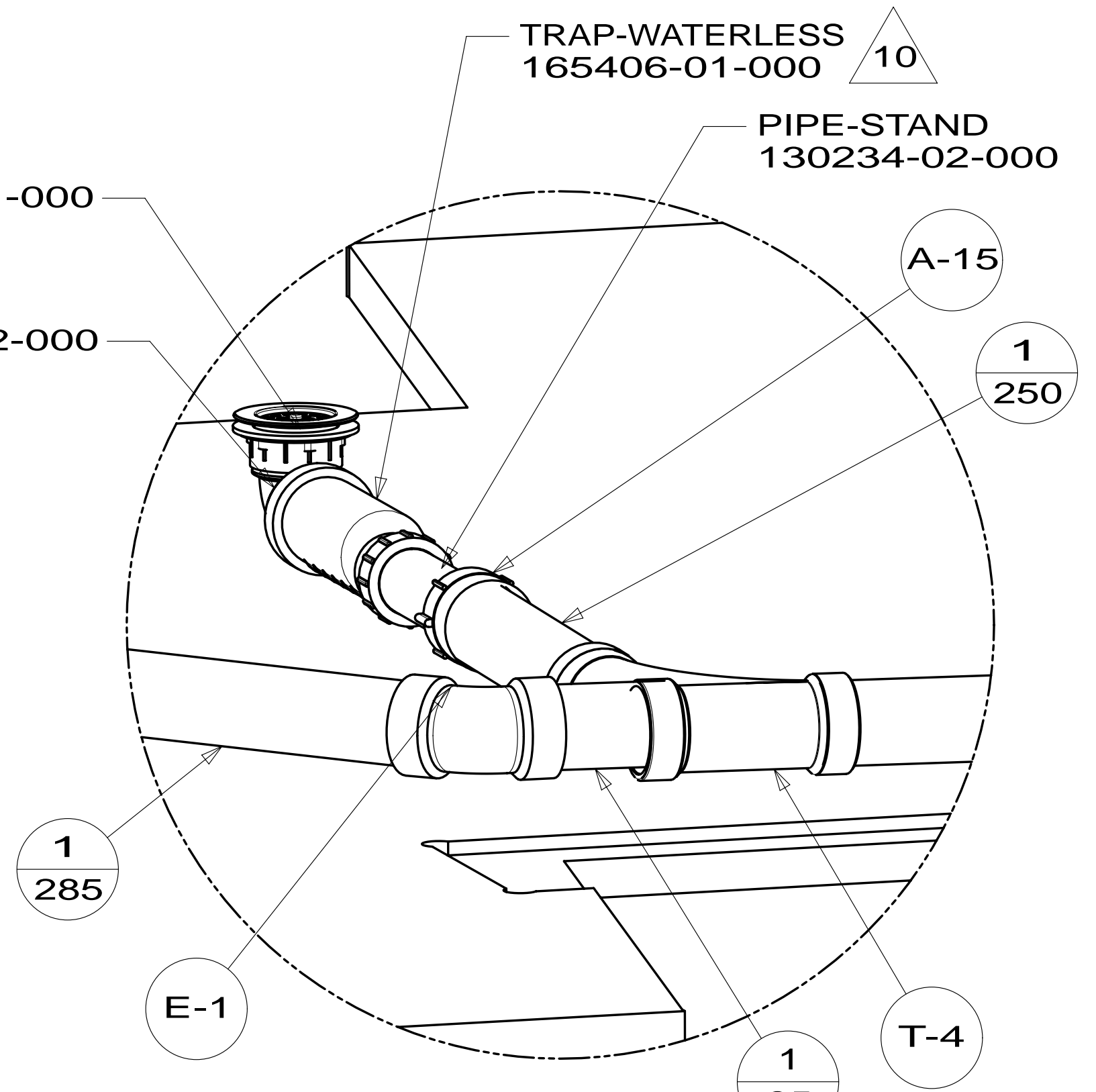

DETAIL C (SHOWN W/OUT SHOWER AND CABINETS)

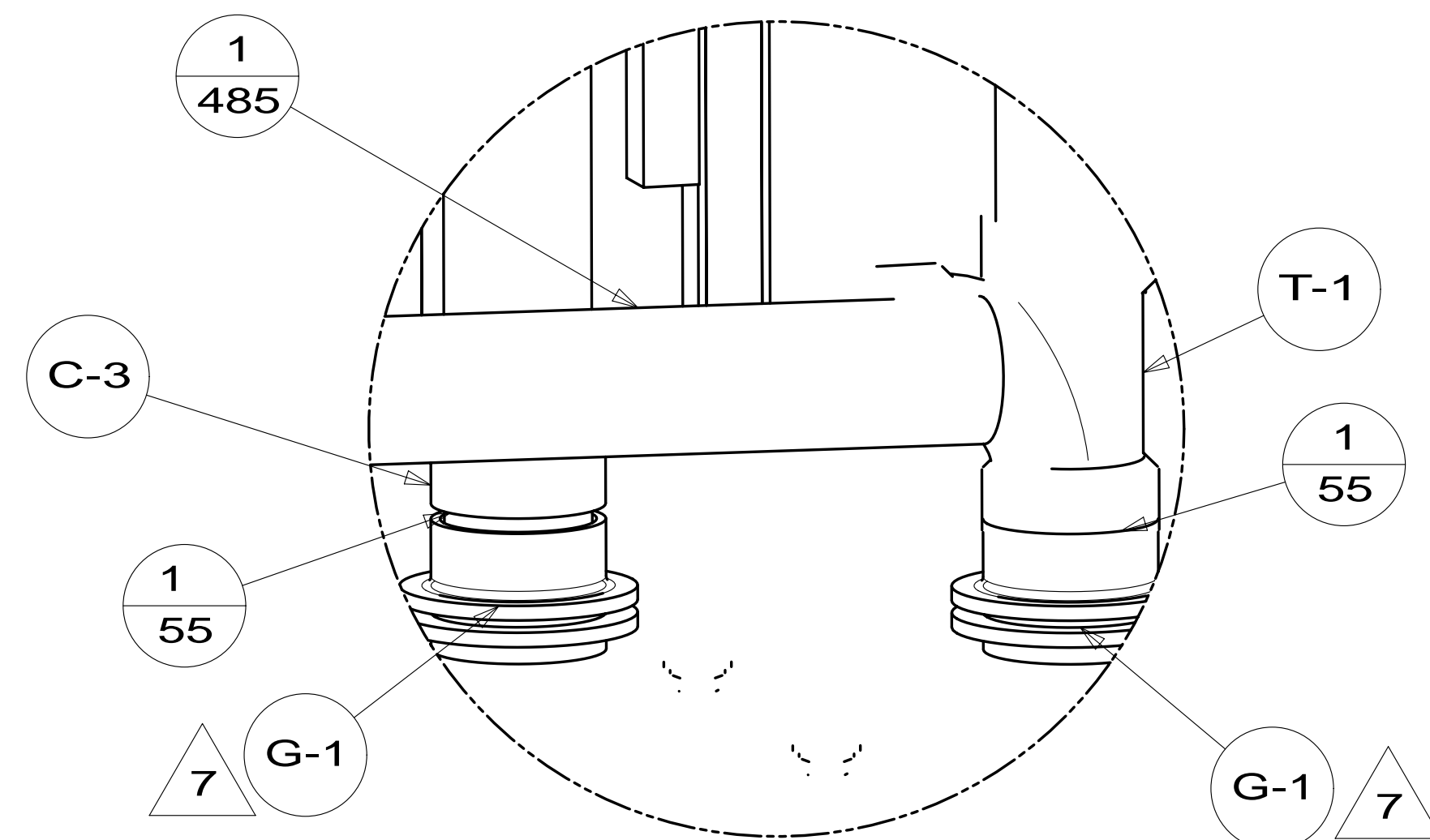

DETAIL D (SHOWN W/OUT FLOOR AND CABINETS)

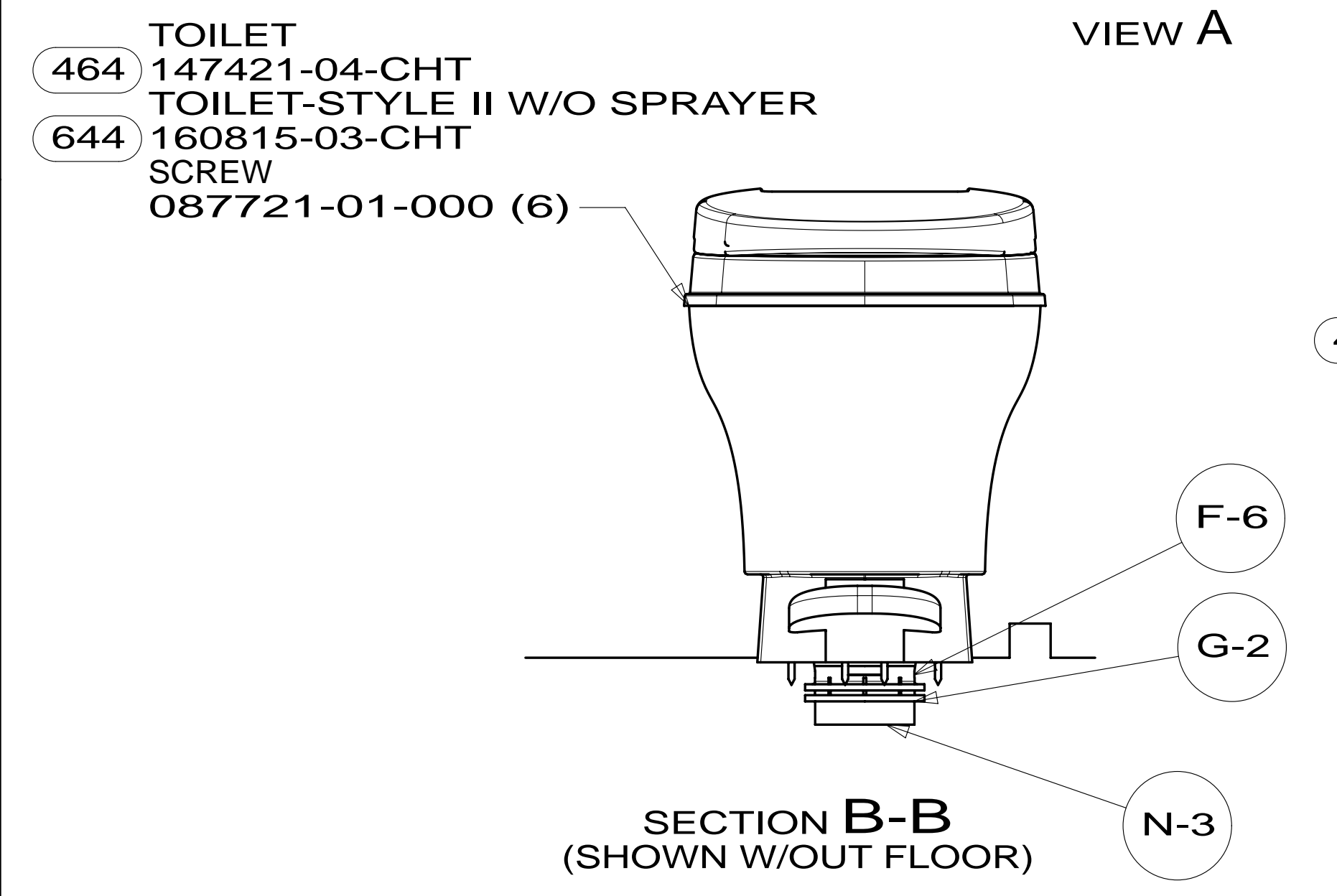

SECTION B-B (SHOWN W/OUT FLOOR)

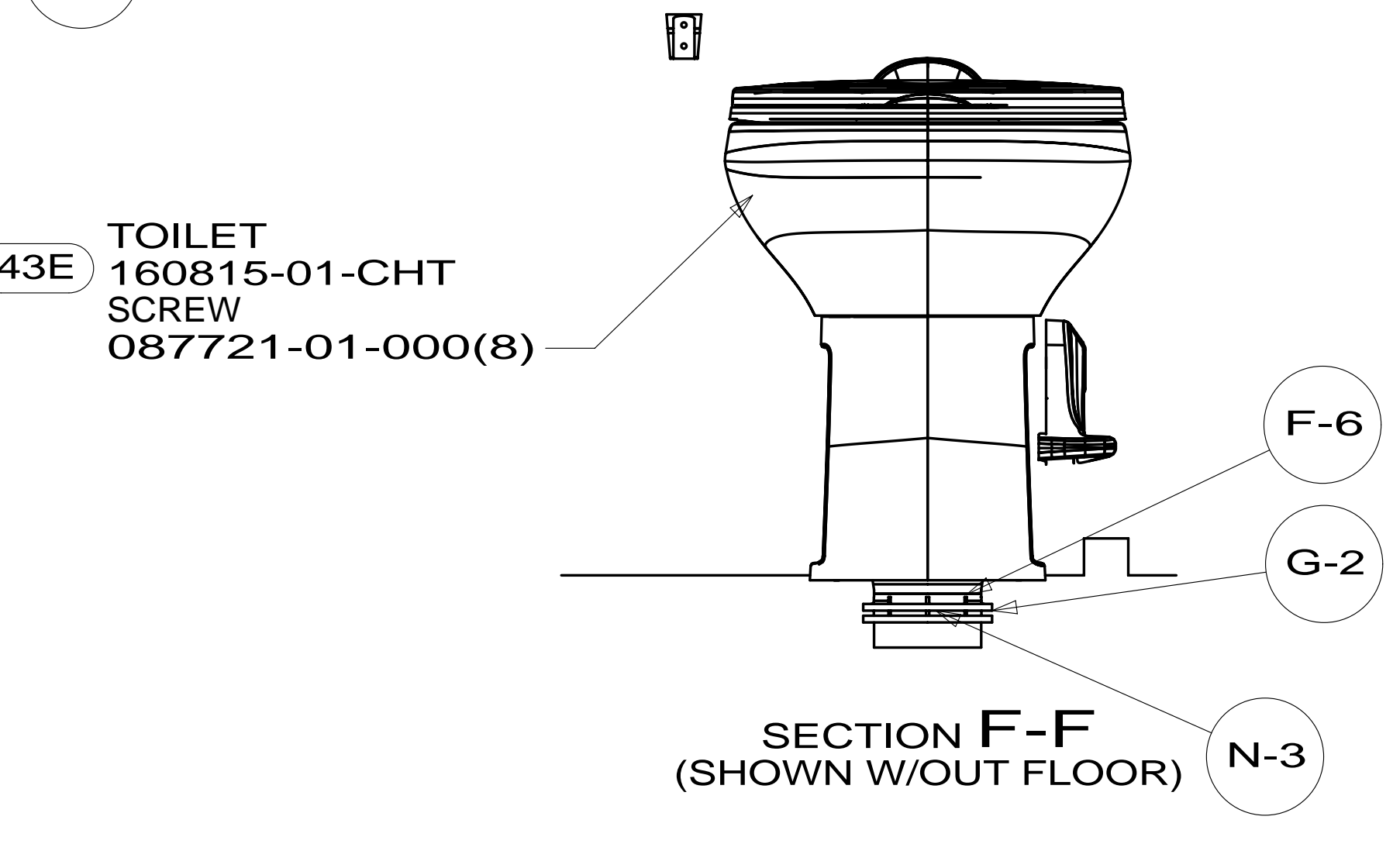

SECTION F-F (SHOWN W/OUT FLOOR)

FIRST USED	13 231J	
TITLE:	DO NOT SCALE DRAWING	
	DRAINAGE SYSTEM INSTL	
SHEET 2	PART NO 181550	REV
		13-Jun-2012

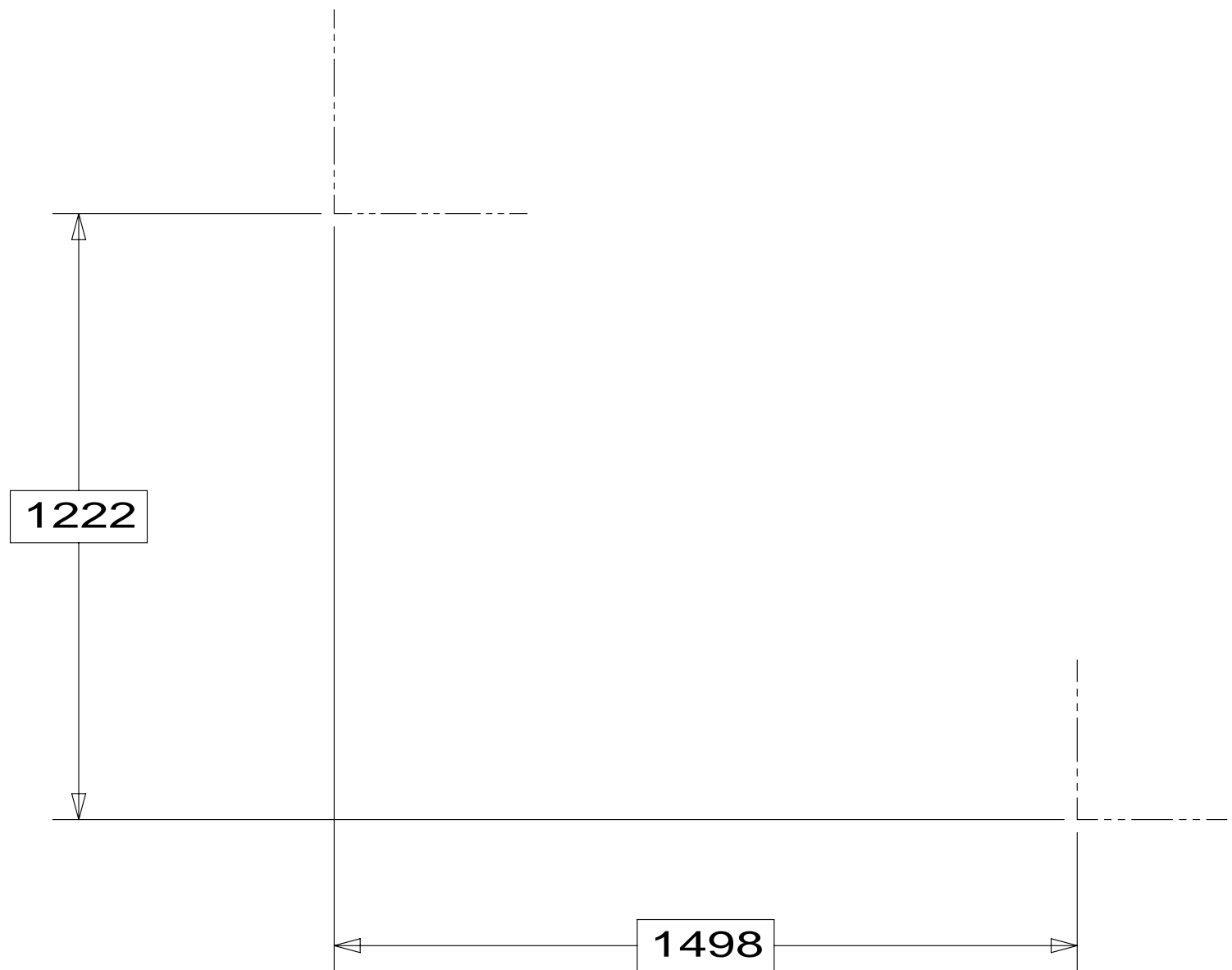

11 PAD-HEATER
133972-04-000
23T 12 INSTALL PER
MANUFACTURERS LABEL

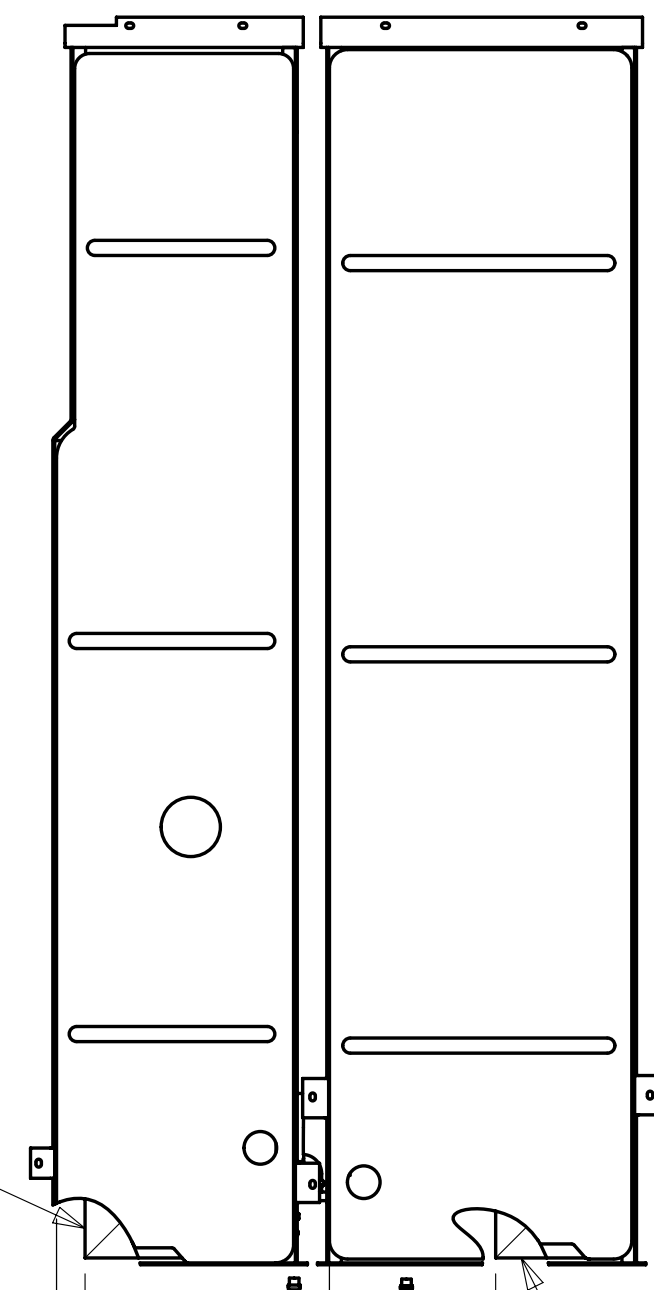

4778 47 5229 275

11 PAD-HEATER
133972-04-000
23T 12 INSTALL PER
MANUFACTURERS LABEL

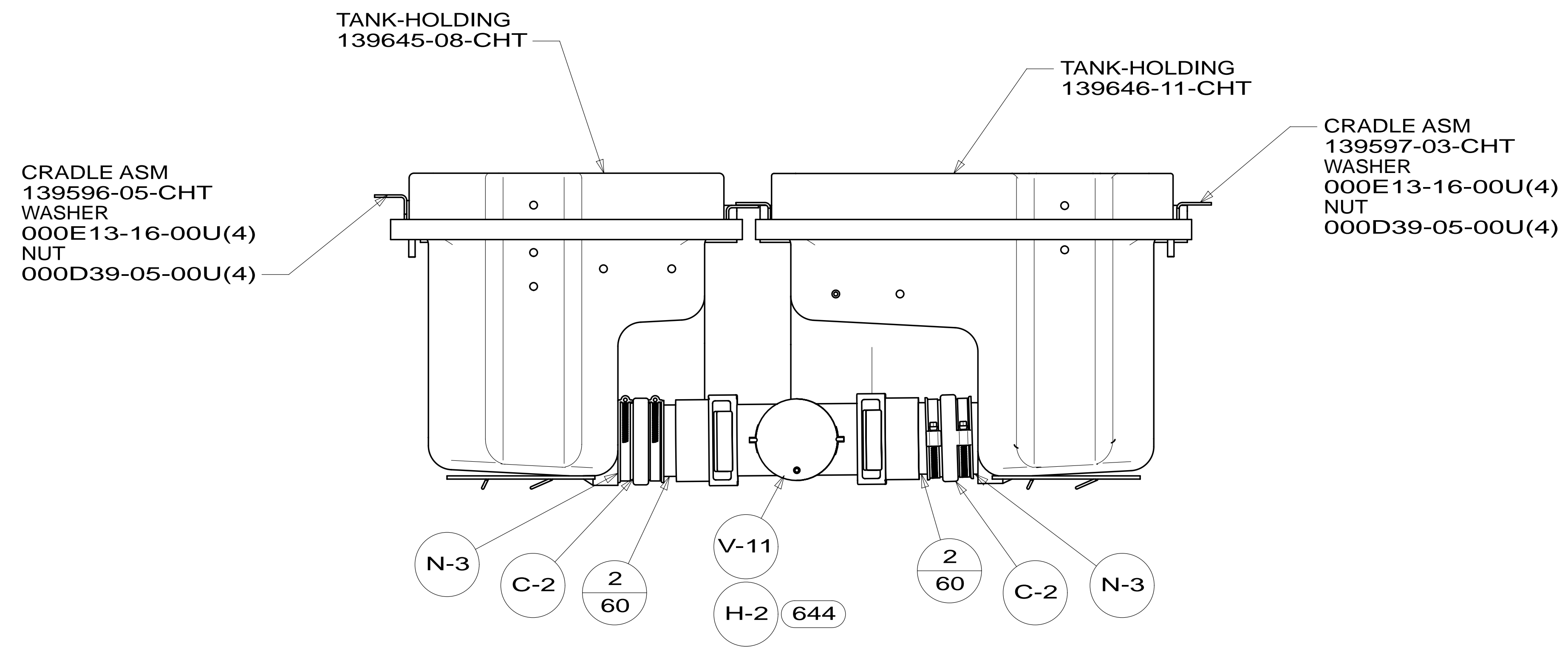
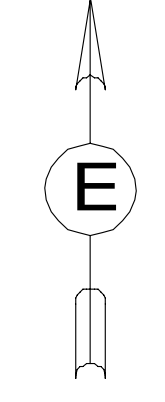

VIEW E

FIRST USED	13 231J	
TITLE:	DO NOT SCALE DRAWING	
TITLE:	DRAINAGE SYSTEM INSTL	
SHEET 3	PART NO 181550	REV

DWG NO	VIEW	MODEL
181549-01	CC, BD	231J
181549-02	CB, BE	231JP

RELEASE	REV DATE	DWG NO	181549
REV ZONE	REVISION RECORD	DATE	DTR-ORIG

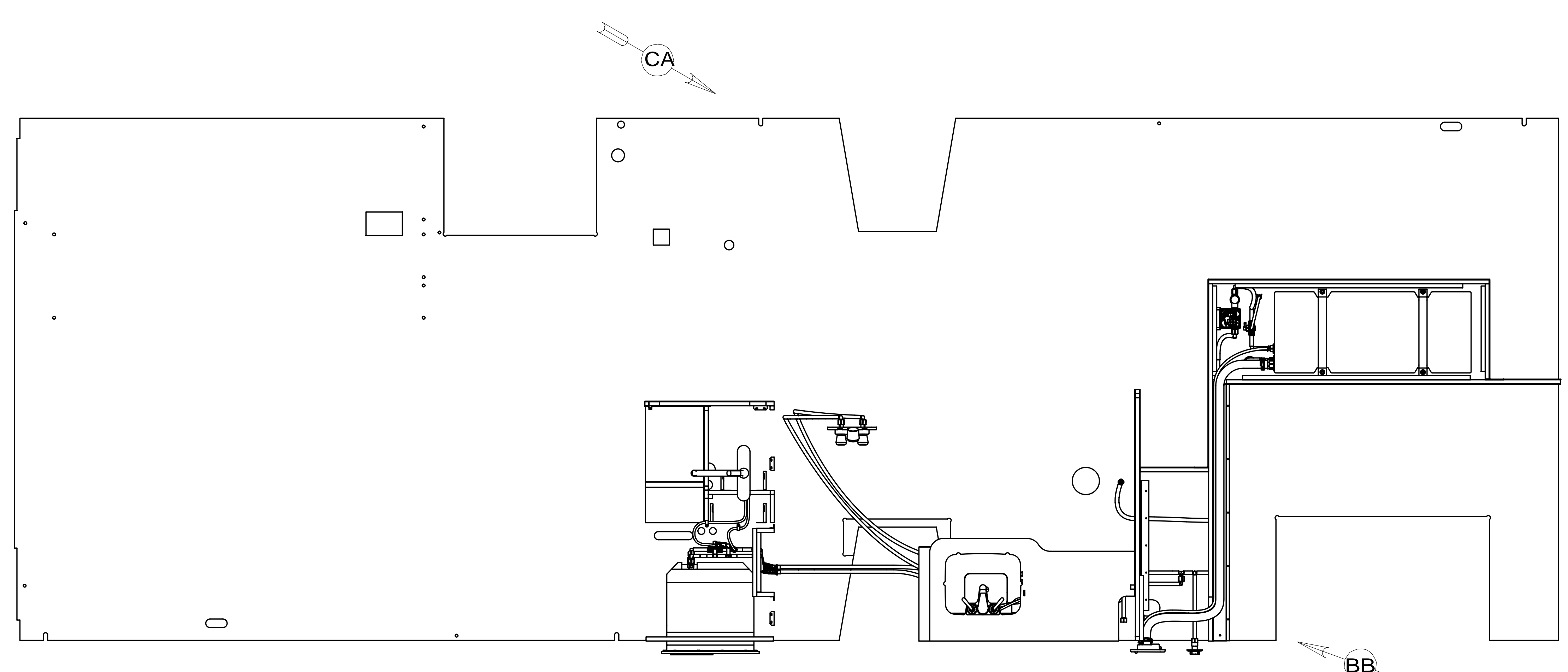

- (644) GREAT ALASKAN RENTAL PACKAGE
- (53Z) WTR HTR-6GAL/110/LP/MTR/AUTO
- (1J4) EXT WASH STATION - WITHOUT
- (64R) EXTERIOR WASH STATION
- (53F) WATER HEATER-ELEC. IGNITION
- (53E) WATER SYS WINTERIZATION PKG

8. ALL CRIMP FITTINGS TO 1/2" PEX TUBING REQUIRE 1/2" CLAMP 140171-03-000.
7. ALL CRIMP FITTINGS TO 5/8" PEX TUBING REQUIRE 5/8" CLAMP 140171-04-000.
6. LABEL HOT AND COLD SUPPLY TUBES AND TAPE FITTING TO TUBE BEFORE CABINET SET TO PREVENT MOVEMENT.
5. ADD PIPE WRAP (LADDER SCRAP 110157-02-000) INSULATION.
4. ADD TEFLON TAPE 010405-02-000.
3. ALL TUBING TO BE SECURED AT 1200 INTERVALS MAXIMUM WITH CLAMP 010495-01-000 AND SCREW 000G67-10-12U OR EQUIVALENT.
2. TUBING TO BE INSTALLED WITH SUFFICIENT SLOPE TO PROVIDE DRAINAGE TO NEAREST VALVE.
1. PLASTIC FITTINGS TO BE SEALED WITH SEALANT 084456-01-000.

NOTES:

		COPYRIGHT 2012 WINNEBAGO INDUSTRIES, INC.
DTR	ORIG. DATE	
CHKR	ALL DIMENSIONS ARE IN MILLIMETERS	
P.E.		
M.E.	FIRST USED	
DSNR	13 231J	
UNSPECIFIED TOLERANCES ARE:		MATERIAL:
WHOLE DIM (X)	: 3	
ONE-PLACE (X.X)	: 1.5	
TWO-PLACE (X.XX)	: 0.50	
ANGLE	: 1°	
THIRD ANGLE PROJECTION		
DO NOT SCALE DRAWING		REFER TO ES0018 FOR FASTENER TIGHTENING GUIDELINES
TITLE: WATER SYSTEM INSTL		
SHEET 1 OF 3	PART NO 181549	REV
REF:	1	13-Jun-2012

FOR WATER CALLOUTS SEE DWG NO 116230-01-000

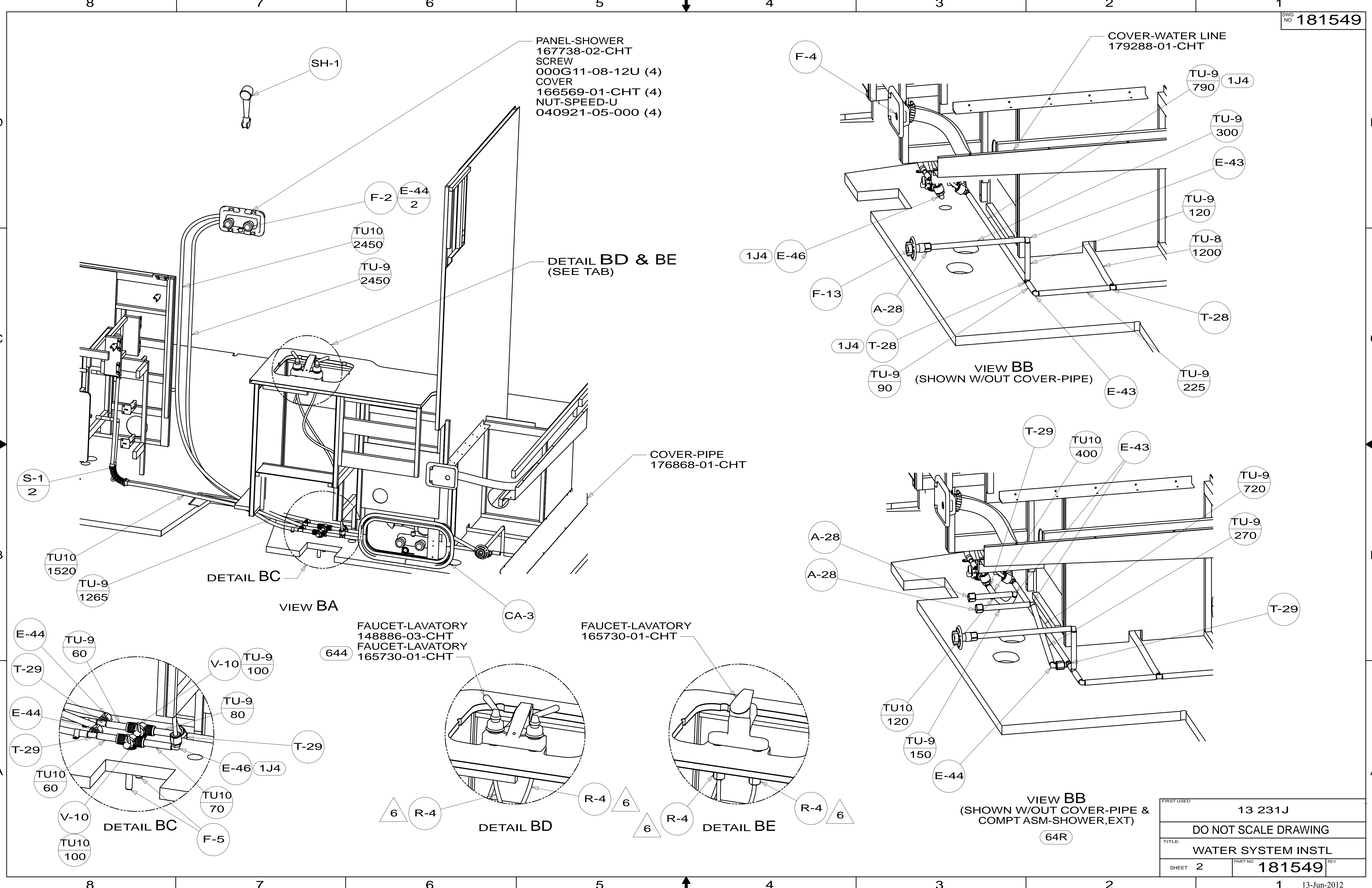

PANEL-SHOWER
167738-02-CHT
SCREW
000G11-08-12U (4)
COVER
166569-01-CHT (4)
NUT-SPEED-U
040921-05-000 (4)

COVER-WATER LINE
179288-01-CHT

DETAIL BD & BE
(SEE TAB)

VIEW BB
(SHOWN W/OUT COVER-PIPE)

COVER-PIPE
176868-01-CHT

VIEW BB
(SHOWN W/OUT COVER-PIPE &
COMPT ASM-SHOWER,EXT)

FAUCET-LAVATORY
148886-03-CHT
FAUCET-LAVATORY
165730-01-CHT

FAUCET-LAVATORY
165730-01-CHT

FIRST USED	13 231J
DO NOT SCALE DRAWING	
TITLE: WATER SYSTEM INSTL	
SHEET 2	PART NO 181549 REV

- TANK ASM
156167-08-000
- STRAP
118994-10-CHT(2)
- WASHER
000E13-16-00U(4)
- NUT
000D39-05-00U(4)
- ELEVATOR BOLT
000C18-05-40U(4)

FAUCET-GALLEY
149164-01-CHT

DETAIL CC
(SEE TAB)

- WATER HEATER
051391-03-000 53F
- 145541-02-000 53Z
- DOOR
125420-06-CHT
- AL EXTR
002726-01-210(2)
- 002726-01-212(2)
- SCREW
000G39-10-169(18)
- SEALANT
069640-14-000
- CABLE
076767-03-000

- FILTER
160946-03-000
- SCREW
000G67-10-12U (2)

DETAIL CD

VIEW CA

DETAIL CB

- CLAMP
010495-01-000
- SCREW
000G67-10-12U

FAUCET-GALLEY
140117-03-CHT

FAUCET-GALLEY
149164-01-CHT

- VALVE
132483-01-000
- ELBOW
132782-01-000
- TUBE
074462-01-000
(100MM)

DETAIL CE

DETAIL CE

DETAIL CD

DETAIL CC

DETAIL CC

FIRST USED	13 231J	
DO NOT SCALE DRAWING		
TITLE:	WATER SYSTEM INSTL	
SHEET 3	PART NO	181549
	REV	