

- 8 USE LOCTITE 062917-06-000 ON ALL THREADS WHEN INSTALLING BRACKET
- 7 SECURE VENT PIPE WITH CLAMP 062401-02-000.
- 6 VENT PIPE MUST PROJECT 51 MIN AND 64 MAX ABOVE ROOF FOR PROPER FIT AND FUNCTION.
- 5. SEAL AROUND SHOWER WITH SILICONE.
- 4. SECURE DRAINAGE PIPES TO CABINET USING WIRE TIE 108046-02-000, AND SCREW 000G67-10-12B AT INTERVALS OF NOT MORE THAN 4 FEET APART.
- 3. ALL PIPE AND FITTINGS TO BE ASSEMBLED WITH SOLVENT 004020-01-000 (USA), 004020-02-000 (CAN)
- 2. SLOPE OF TRAP ARM MUST BE 6 PER 305 mm.
- 1. SLOPE OF HORIZONTAL PIPING TO BE MINIMUM OF 3 PER 305 mm.

NOTES:

		COPYRIGHT 2012 WINNEBAGO INDUSTRIES, INC.	
DTR	ORIG. DATE	ALL DIMENSIONS ARE IN MILLIMETERS	
CHKR			
P.E.			
M.E.	FIRST USED		
DSNR		12 BM170X	
UNSPECIFIED TOLERANCES ARE:		MATERIAL:	
WHOLE DIM (X)	: 3		
ONE-PLACE (X.X)	: 1.5		
TWO-PLACE (X.XX)	: 0.50		
ANGLE	: 1°		
THIRD ANGLE PROJECTION			
DO NOT SCALE DRAWING		REFER TO ES0018 FOR FASTENER TIGHTENING GUIDELINES	
TITLE: DRAINAGE SYSTEM INSTL			
SHEET 1 OF 5	PART NO	178254	REV
REF:	1		

FOR DRAINAGE CALLOUTS SEE DWG NO 116229-01-000

SINK-GALLEY
165378-01-CHT
FAUCET
165378-02-CHT
SEAL
091255-02-000
STRAINER
163659-01-000

ADAPTER-IN LINE
165406-03-000

ADAPTER-ANGLE
165406-02-000

TRAP-WATERLESS
165406-01-000

PIPE-STAND
130234-02-000

CONNECTOR
152146-01-000

SPACER
166672-06-CHT
SCREW
000G39-10-169 (6)

SINK-LAV
151679-01-CHT
SEAL
091255-03-000
STRAINER
163569-01-000

ADAPTER-IN LINE
165406-03-000

ADAPTER-ANGLE
165406-02-000

TRAP-WATERLESS
165406-01-000

PIPE-STAND
130234-02-000

CONNECTOR
152146-01-000

GASKET
167219-03-CHT
(UNDER WOOD FLOOR)

VIEW A

VIEW B

FIRST USED	12 BM170X
DO NOT SCALE DRAWING	
TITLE:	DRAINAGE SYSTEM INSTL
SHEET 2	PART NO 178254
REV	2/6/2012

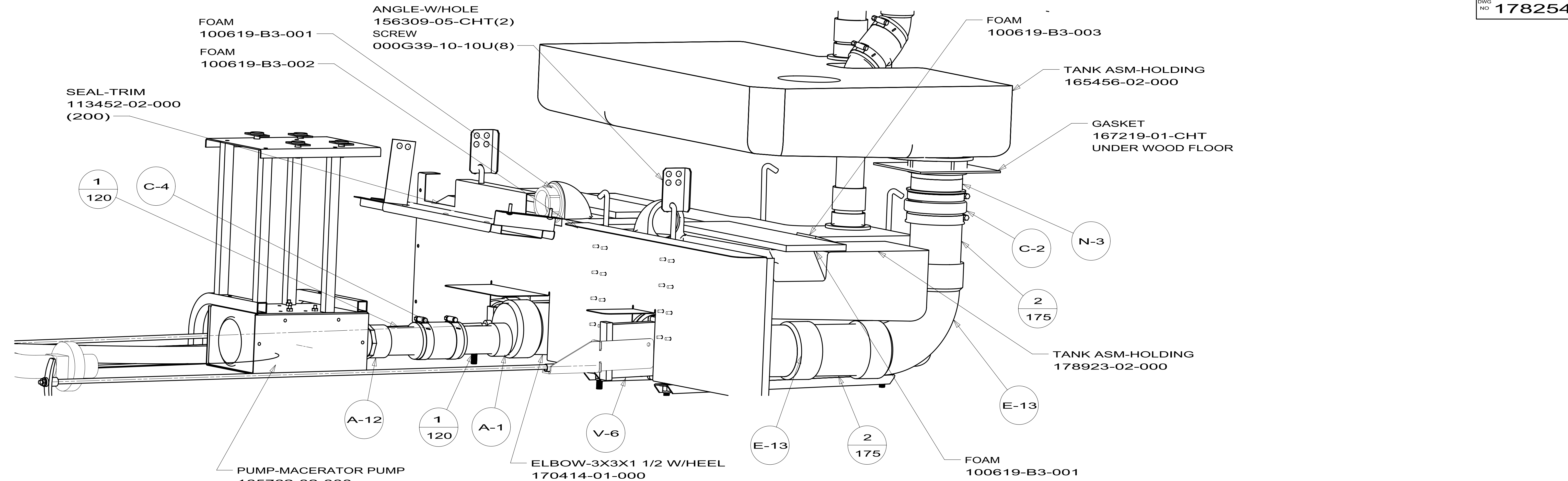

VIEW C

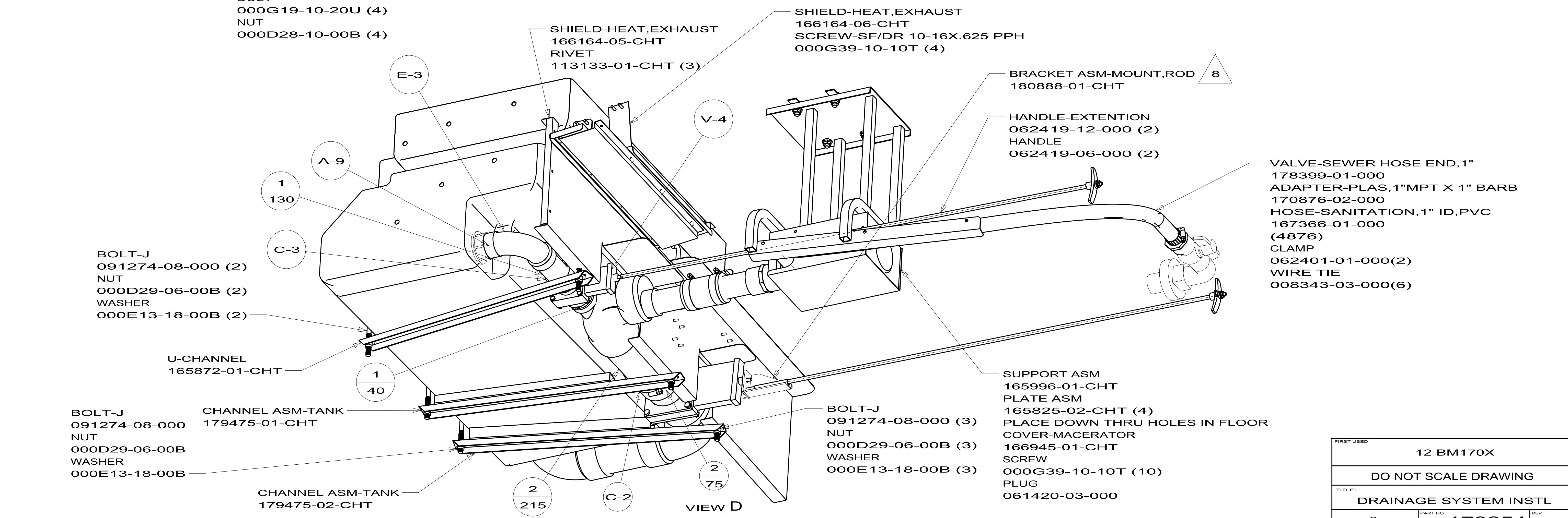

VIEW D

FIRST USED	12 BM170X	
TITLE:	DO NOT SCALE DRAWING	
SHEET 3	PART NO	178254
	REV	

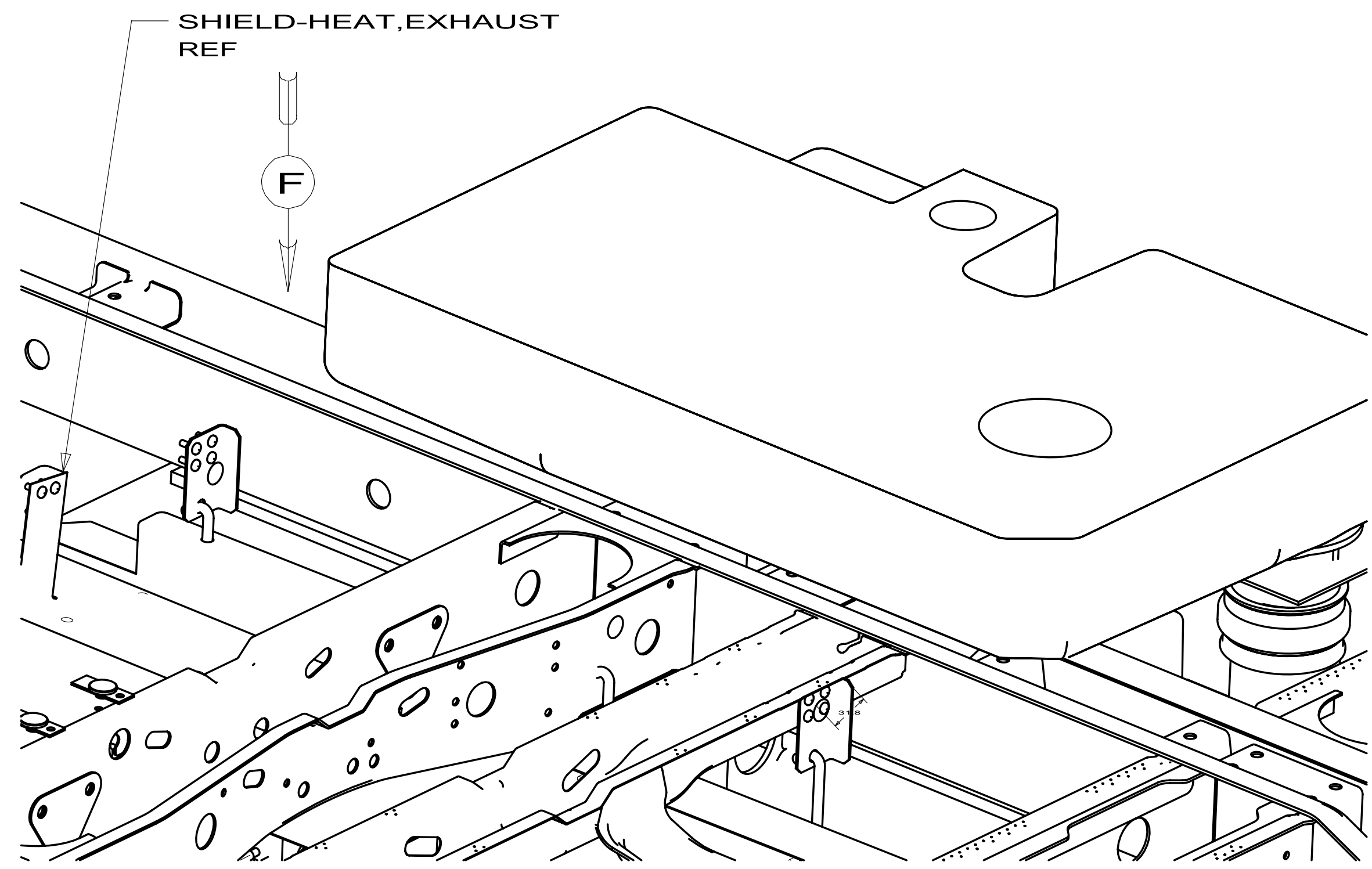

VIEW E

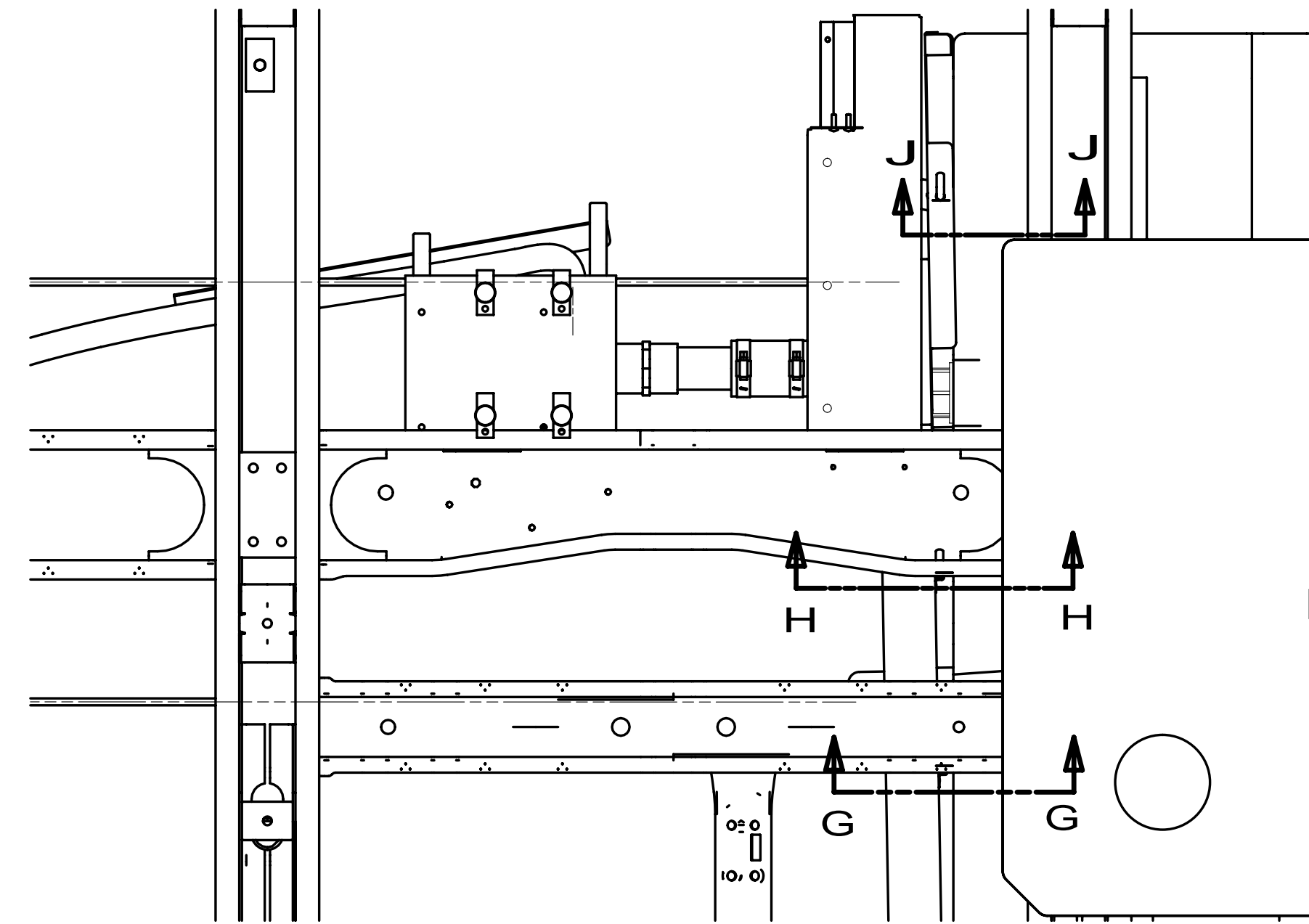

VIEW F

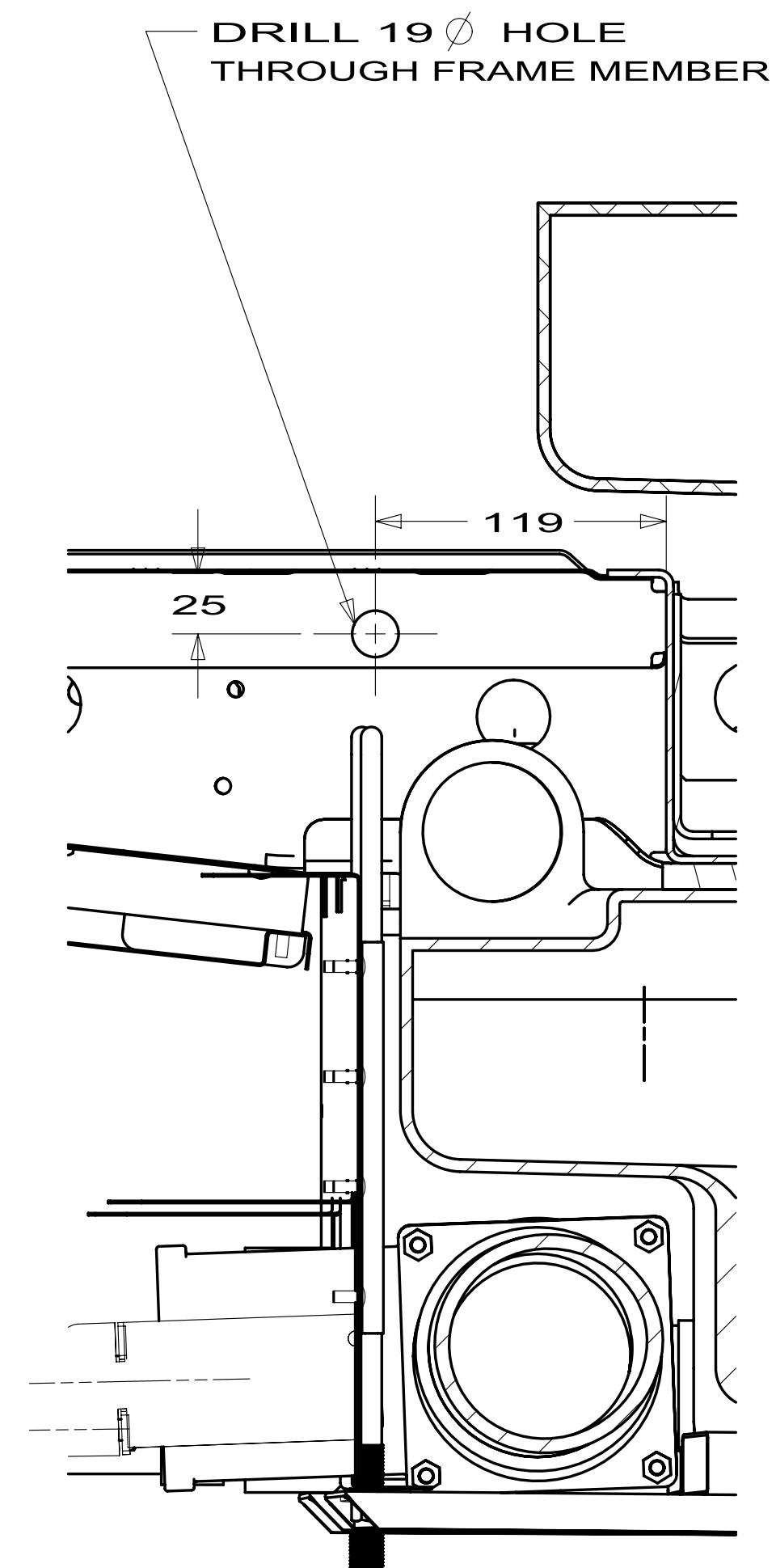

SECTION G-G

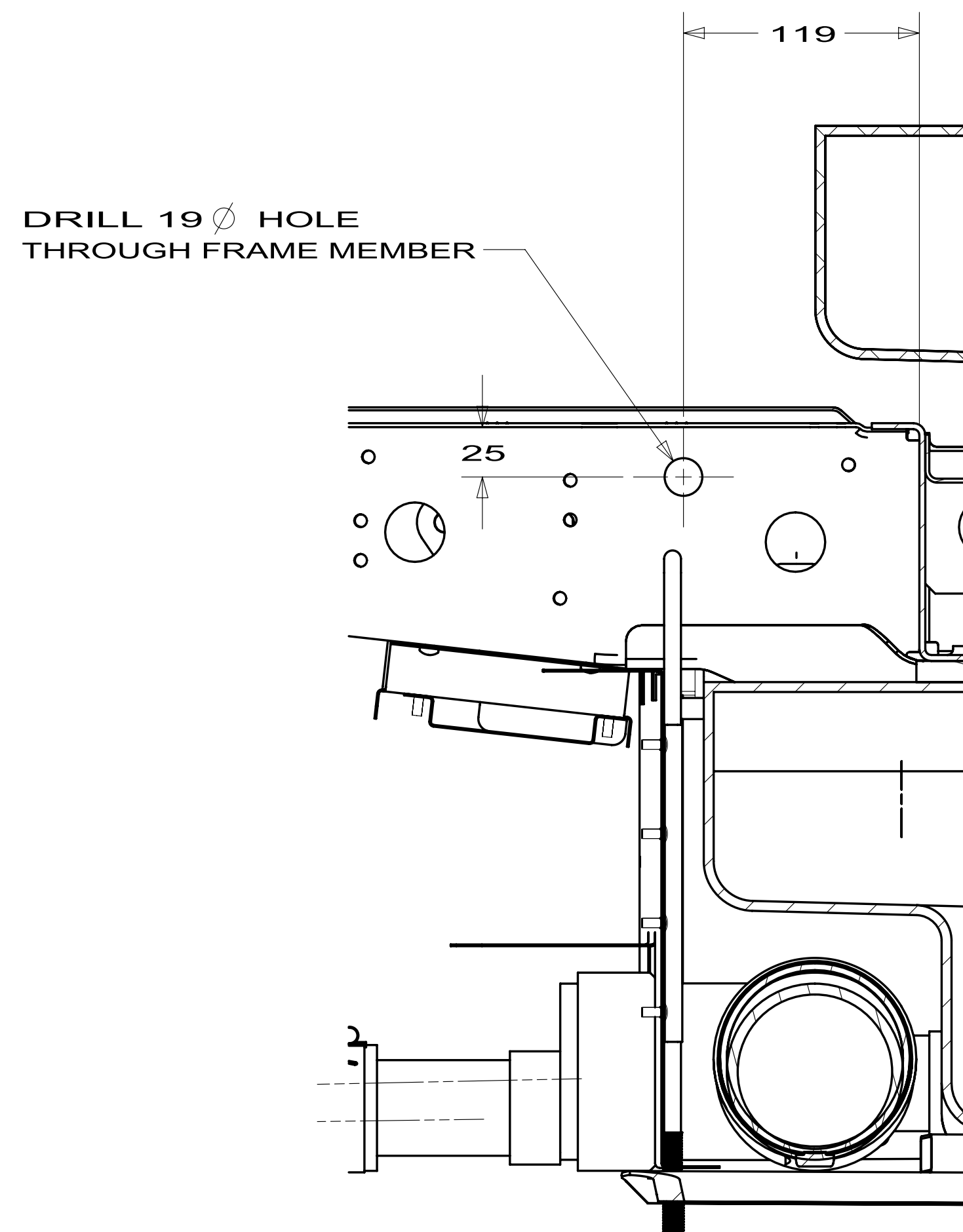

SECTION H-H

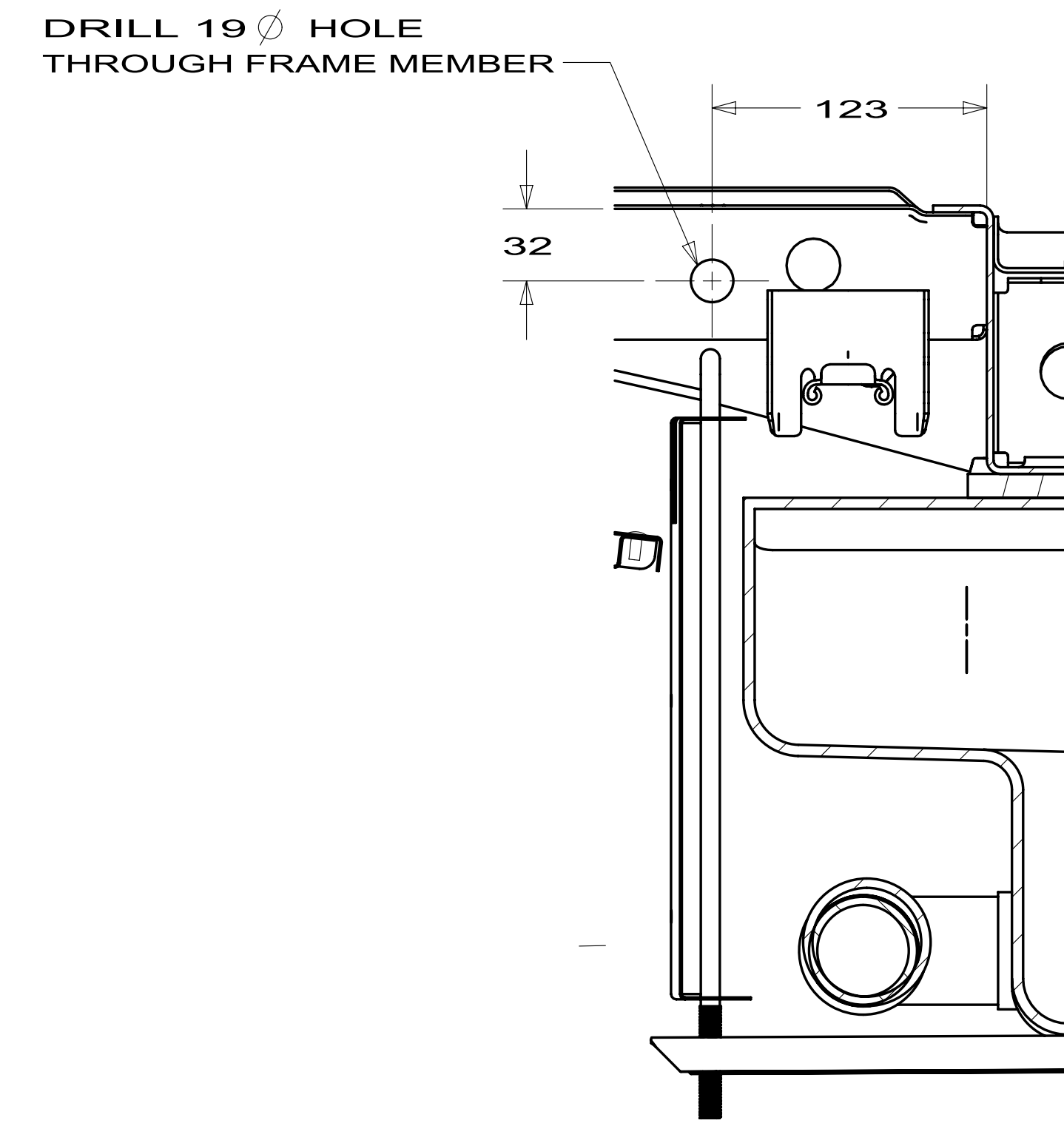

SECTION J-J

FIRST USED	12 BM170X	
TITLE:	DO NOT SCALE DRAWING	
	DRAINAGE SYSTEM INSTL	
SHEET 4	PART NO 178254	REV

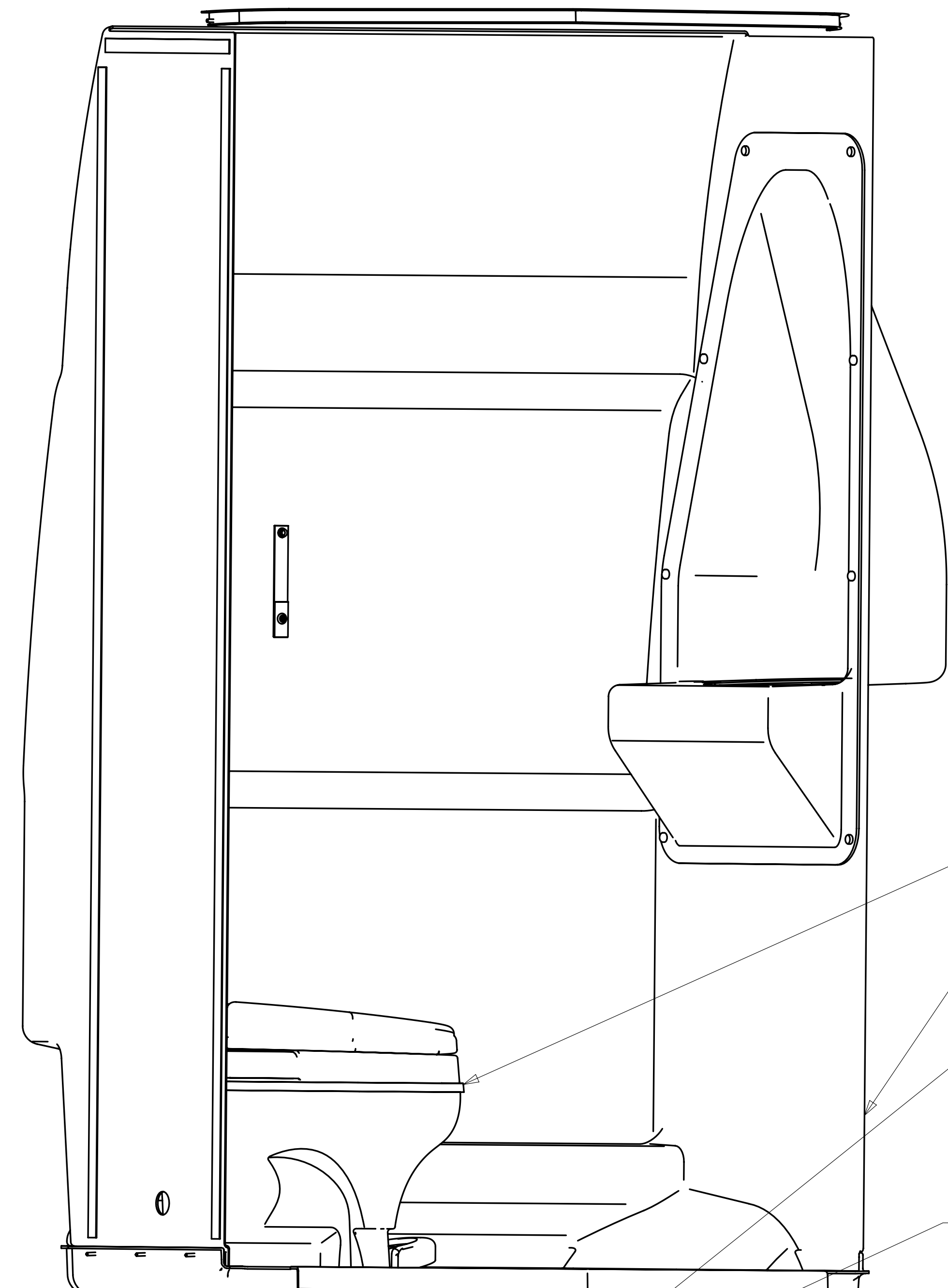

TOILET
147421-02-CHT

SHOWER INSTL
178627-01-XXX

STRAINER
066440-01-000
SEALANT
084456-01-000
NUT
130403-01-000

WASHER-RUBBER
127440-02-000

GASKET
167219-02-CHT
UNDER WOOD FLOOR

FLANGE
2 167352-01-000

ADAPTER-ANGLE
165406-02-000

TRAP-WATERLESS
165406-01-000

PIPE-STAND
130234-03-000

VIEW K

2 SEAL TOILET FLANGE TO SHOWER PAN WITH SILICONE.

1 NIPPLE TO BE TRIMMED TO LENGTH ON INSTALL.

NOTES:

FIRST USED	12 BM170X		
TITLE:	DRAINAGE SYSTEM INSTL		
SHEET 5	PART NO	178254	REV

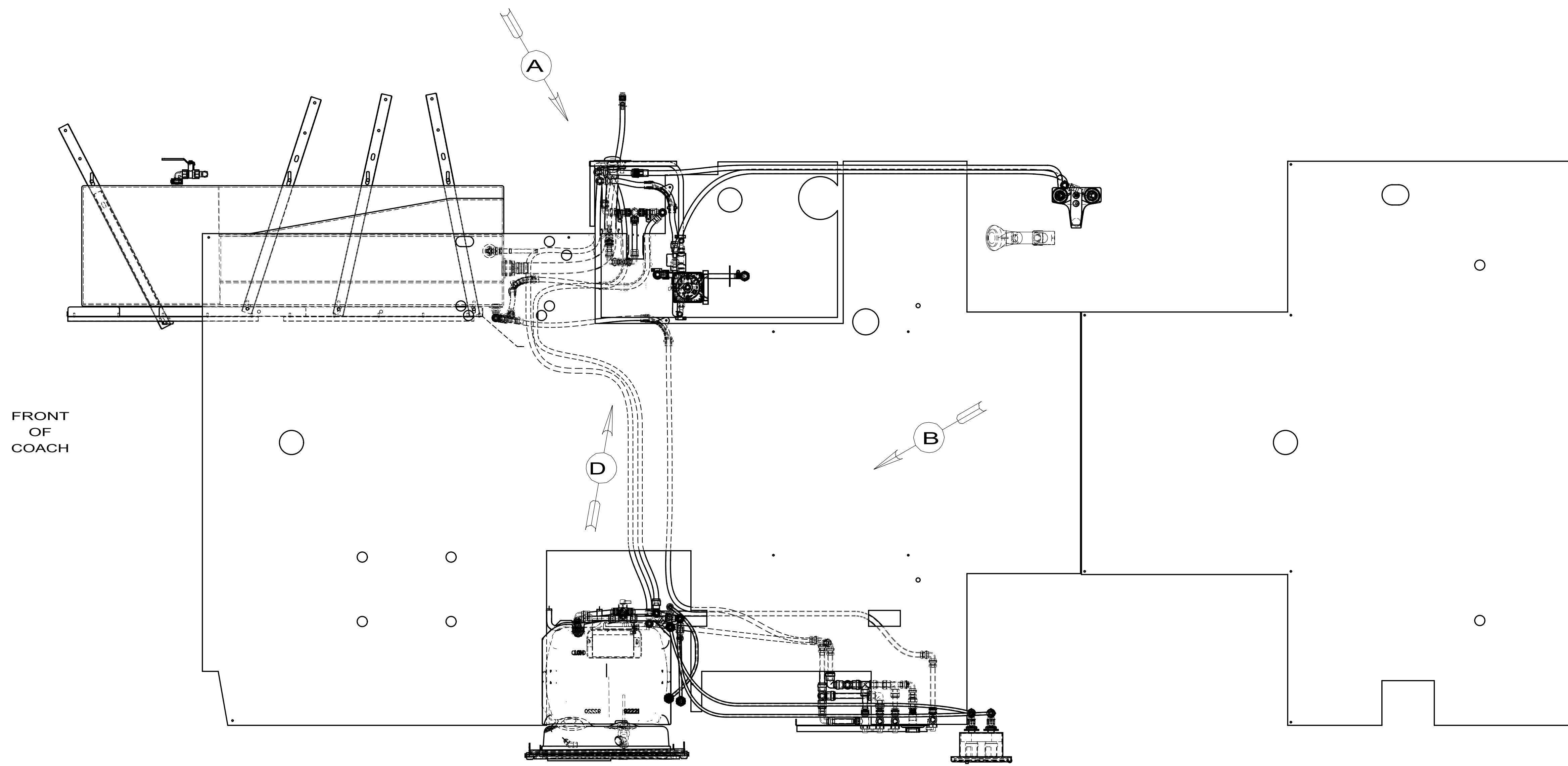

FRONT OF COACH

- 29B WATER PURIFIER
- 501 WATER PURIFIER WITHOUT
- 53B WTR HTR-6 GAL ELEC/LP/GAS

- NOTES:
- 6 ADD TEFLON TAPE 010405-03-000.
 - 5 ADD TEFLON TAPE 010405-02-000.
 - 4 ADD TEFLON TAPE 010405-01-000.
 - 3. ALL TUBING TO BE SECURED AT 1200 INTERVALS MAXIMUM WITH CLAMP 010495-01-000 AND SCREW 000G67-10-12B OR EQUIVALENT.
 - 2. TUBING TO BE INSTALLED WITH SUFFICIENT SLOPE TO PROVIDE DRAINAGE TO NEAREST VALVE.
 - 1. PLASTIC FITTINGS TO BE SEALED WITH SEALANT 084456-01-000.

		COPYRIGHT 2011 WINNEBAGO INDUSTRIES, INC.	
DTR	ORIG. DATE	ALL DIMENSIONS ARE IN MILLIMETERS	
CHKR			
P.E.			
M.E.	FIRST USED		
DSNR		12 170X	
UNSPECIFIED TOLERANCES ARE:		MATERIAL:	
WHOLE DIM (X)	: 3		
ONE-PLACE (X.X)	: 1.5		
TWO-PLACE (X.XX)	: 0.50		
ANGLE	: 1°		
THIRD ANGLE PROJECTION			
DO NOT SCALE DRAWING		REFER TO ES0018 FOR FASTENER TIGHTENING GUIDELINES	
TITLE: WATER SYSTEM INSTL			
SHEET 1 OF 3	PART NO 178835	REV	
REF:	1	12/28/2011	

FOR WATER CALLOUTS SEE DWG NO 116230-01-000

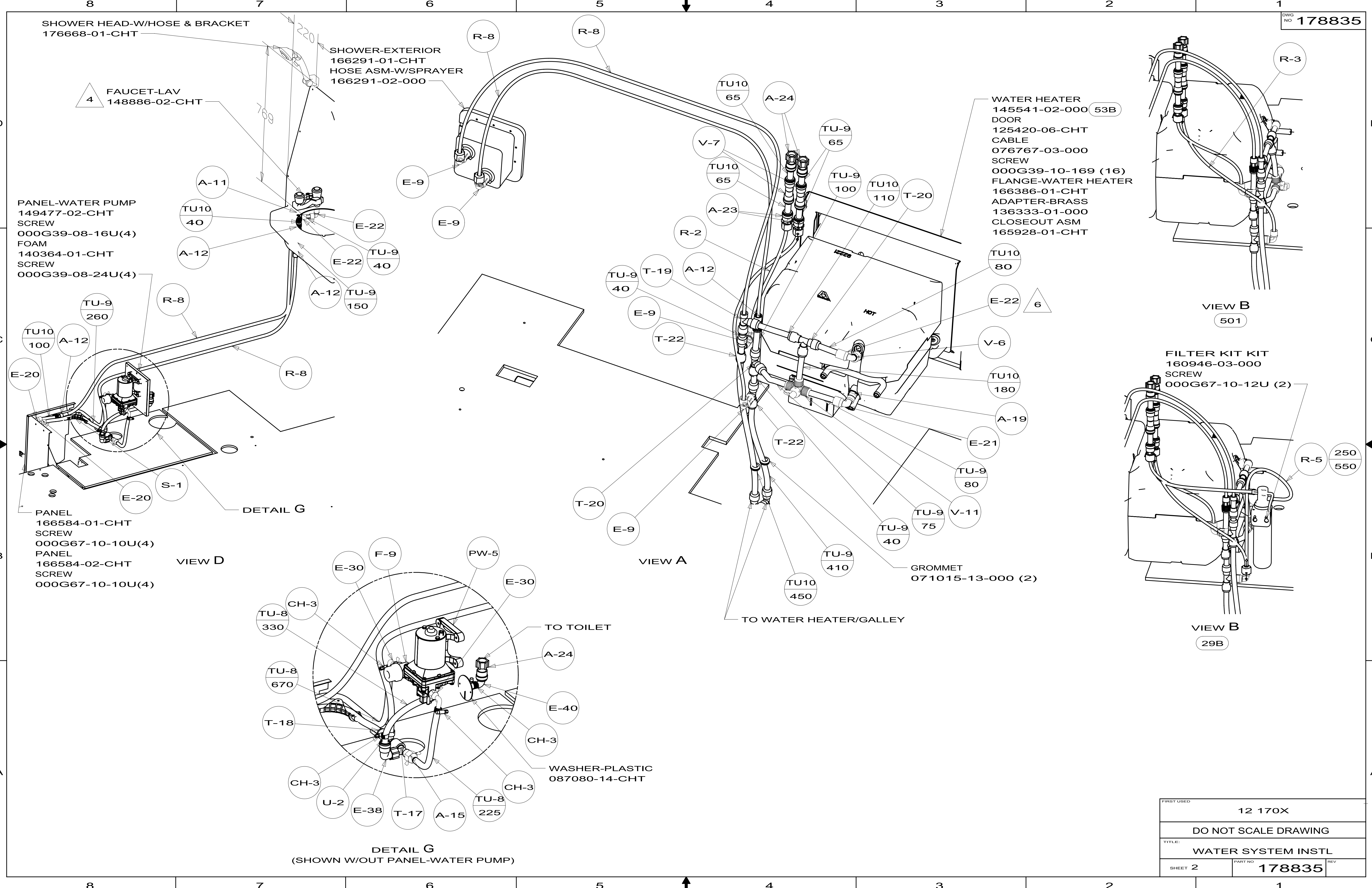

SHOWER HEAD-W/HOSE & BRACKET
176668-01-CHT

SHOWER-EXTERIOR
166291-01-CHT
HOSE ASM-W/SPRAYER
166291-02-000

FAUCET-LAV
148886-02-CHT

PANEL-WATER PUMP
149477-02-CHT
SCREW
000G39-08-16U(4)
FOAM
140364-01-CHT
SCREW
000G39-08-24U(4)

WATER HEATER
145541-02-000 53B
DOOR
125420-06-CHT
CABLE
076767-03-000
SCREW
000G39-10-169 (16)
FLANGE-WATER HEATER
166386-01-CHT
ADAPTER-BRASS
136333-01-000
CLOSEOUT ASM
165928-01-CHT

PANEL
166584-01-CHT
SCREW
000G67-10-10U(4)
PANEL
166584-02-CHT
SCREW
000G67-10-10U(4)

FILTER KIT KIT
160946-03-000
SCREW
000G67-10-12U (2)

TO TOILET

WASHER-PLASTIC
087080-14-CHT

GROMMET
071015-13-000 (2)

DETAIL G
(SHOWN W/OUT PANEL-WATER PUMP)

FIRST USED	12 170X	
TITLE:	DO NOT SCALE DRAWING	
TITLE:	WATER SYSTEM INSTL	
SHEET 2	PART NO	178835
	REV	

- U-CHANNEL 165872-03-CHT
- BOLT-HOOK 091274-08-000
- BOLT HOOK 091274-06-000
- WASHER 000E13-18-00U (2)
- NUT 000D29-06-00U (2)
- TUBE 122737-51-088
- TAPE 76322-02-000 (400) (TAPE TUBE TO TOP OF CHANNEL)

- CLAMP-HOSE 062401-01-000

- U-CHANNEL 165872-03-CHT (3)
- BOLT-HOOK 091274-08-000 (3)
- BOLT-HOOK 091274-06-000 (3)
- WASHER 000E13-18-00U (6)
- NUT 000D29-06-00U (6)

- GROMMET 023942-01-000

- GROMMET 016188-10-000 (3)

TANK ASM-WATER, 28 GAL 165457-02-000

SHIELD ASM-EXHAUST 166164-01-CHT

NUT 000D39-06-00U TOP SIDE OF CHANNEL

NUT 000D39-06-00U (3) TOP SIDE OF CHANNEL

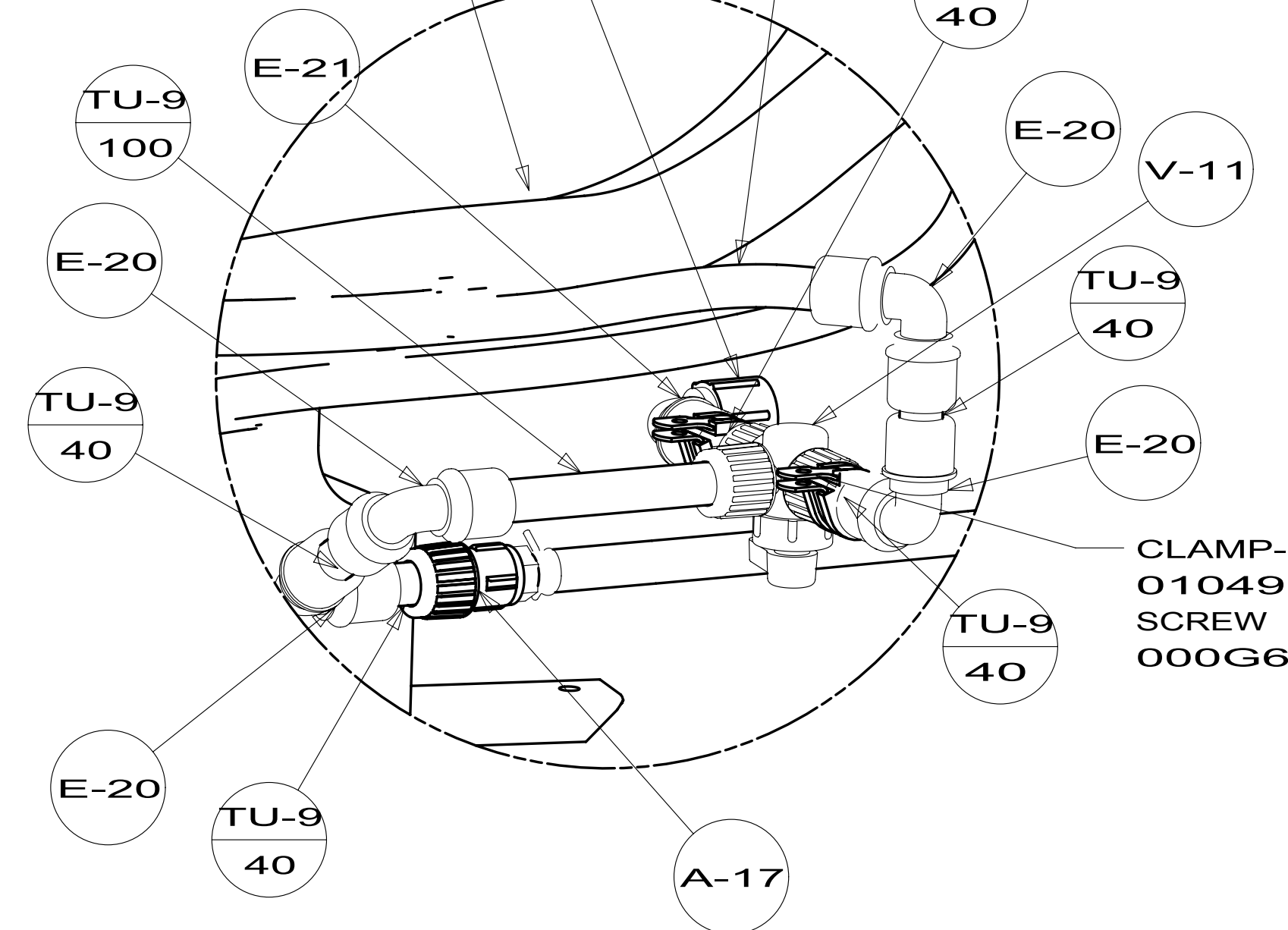

DETAIL F

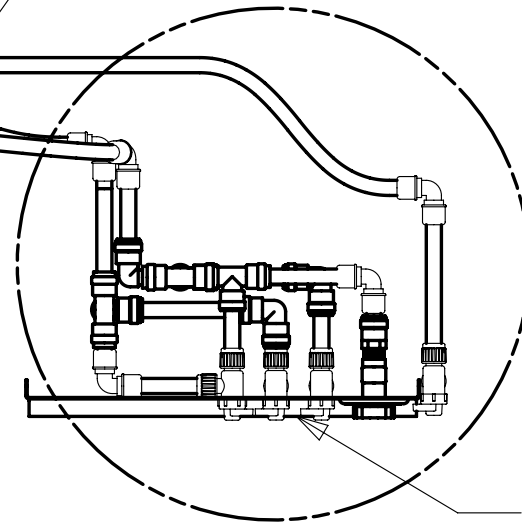

DETAIL E

PANEL-WATER CENTER 167283-02-CHT

WATER LINES AND TANKS UNDER FLOOR

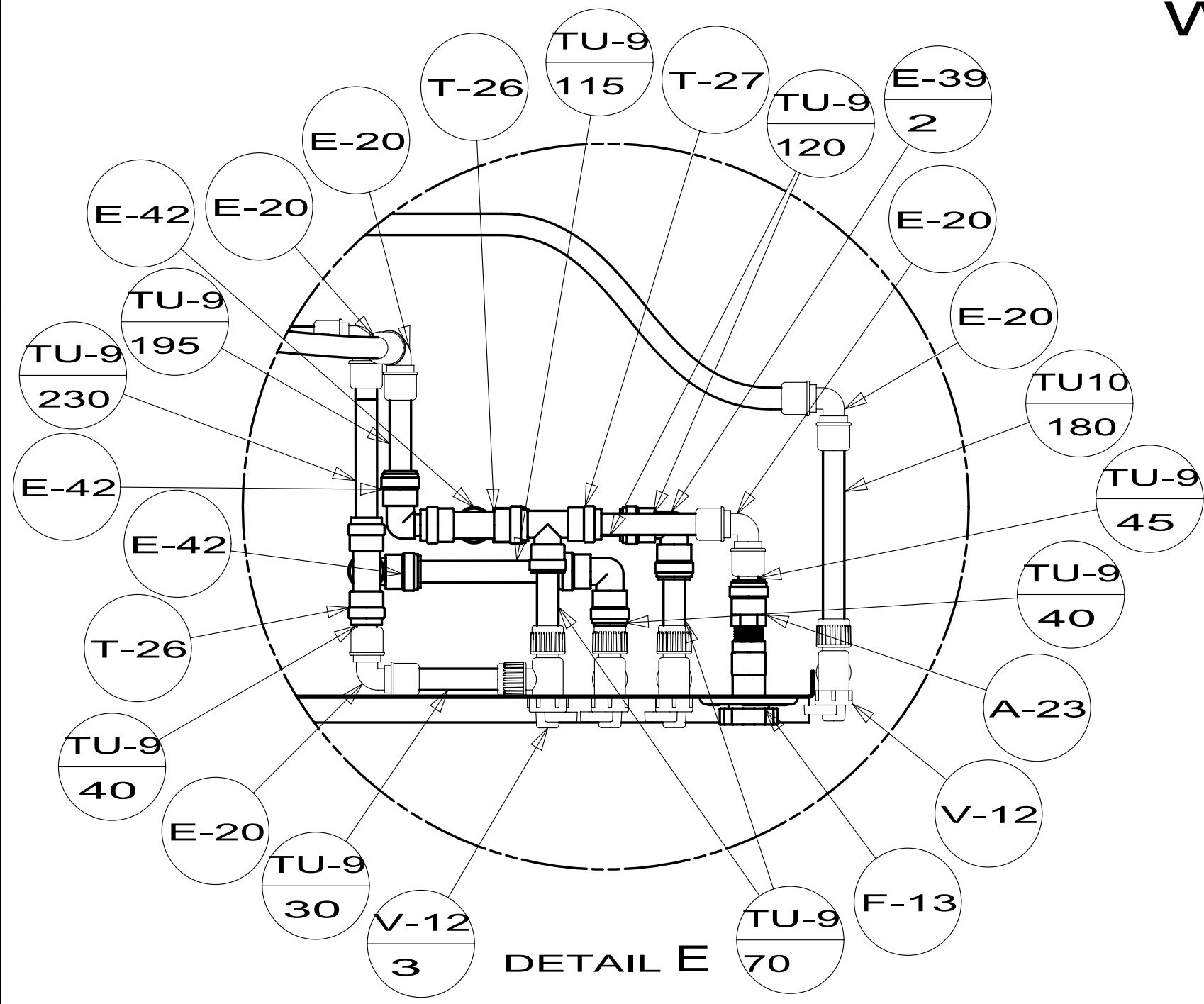

DETAIL E

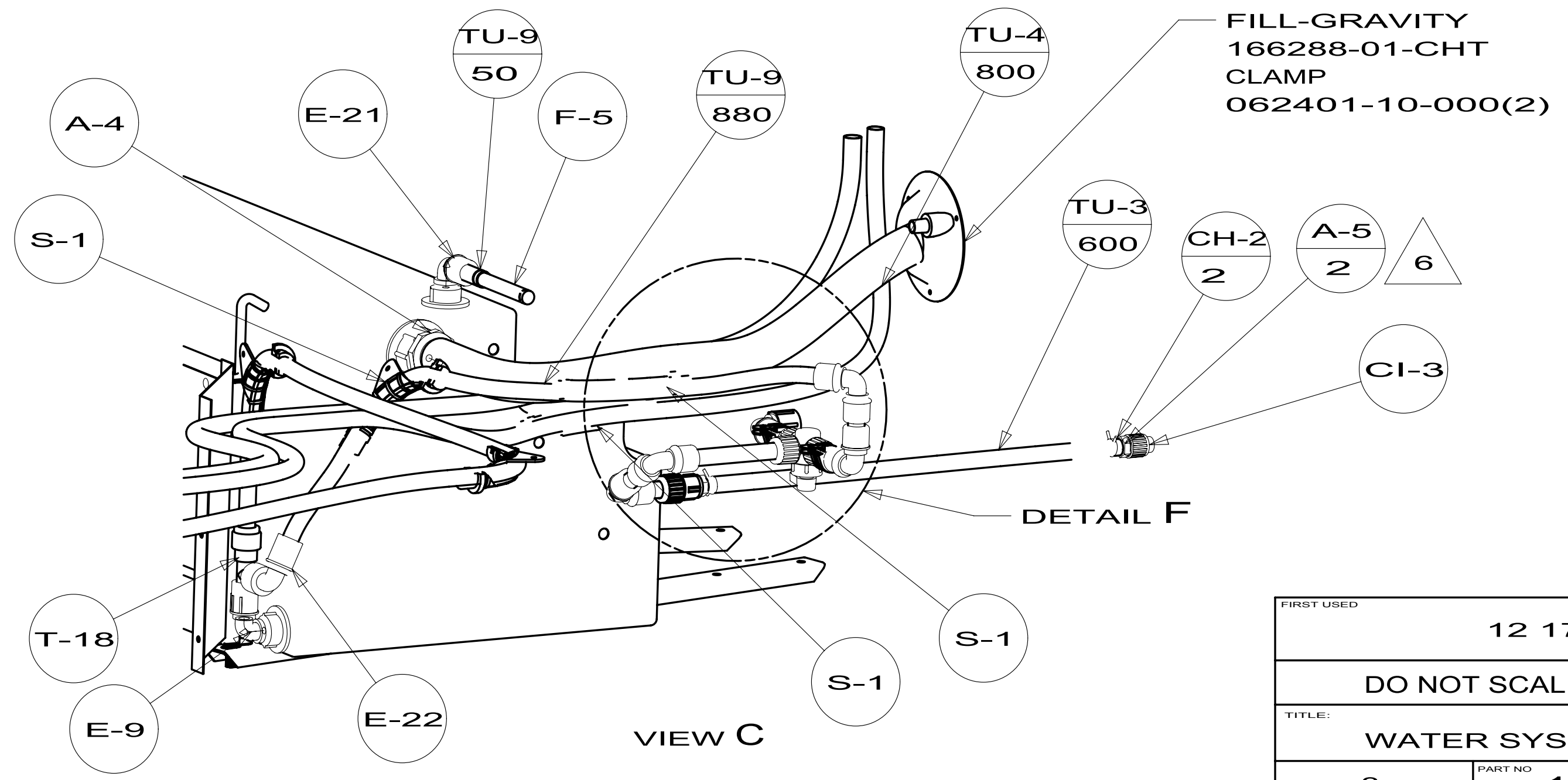

VIEW C

FIRST USED	12 170X	
TITLE:	DO NOT SCALE DRAWING	
SHEET 3	PART NO	178835
	REV	