



DANGER

Danger of electrical shock, burns or death. Always remove all power sources before attempting any repair, service or diagnostic work. Power can be present from shore power, generator, inverter or battery. All power sources must be disabled and secured before performing any service.



CAUTION

If you lack the skills, tools or equipment to perform diagnostic or repair work leave such work to an authorized Winnebago Industries dealer or other qualified shop.

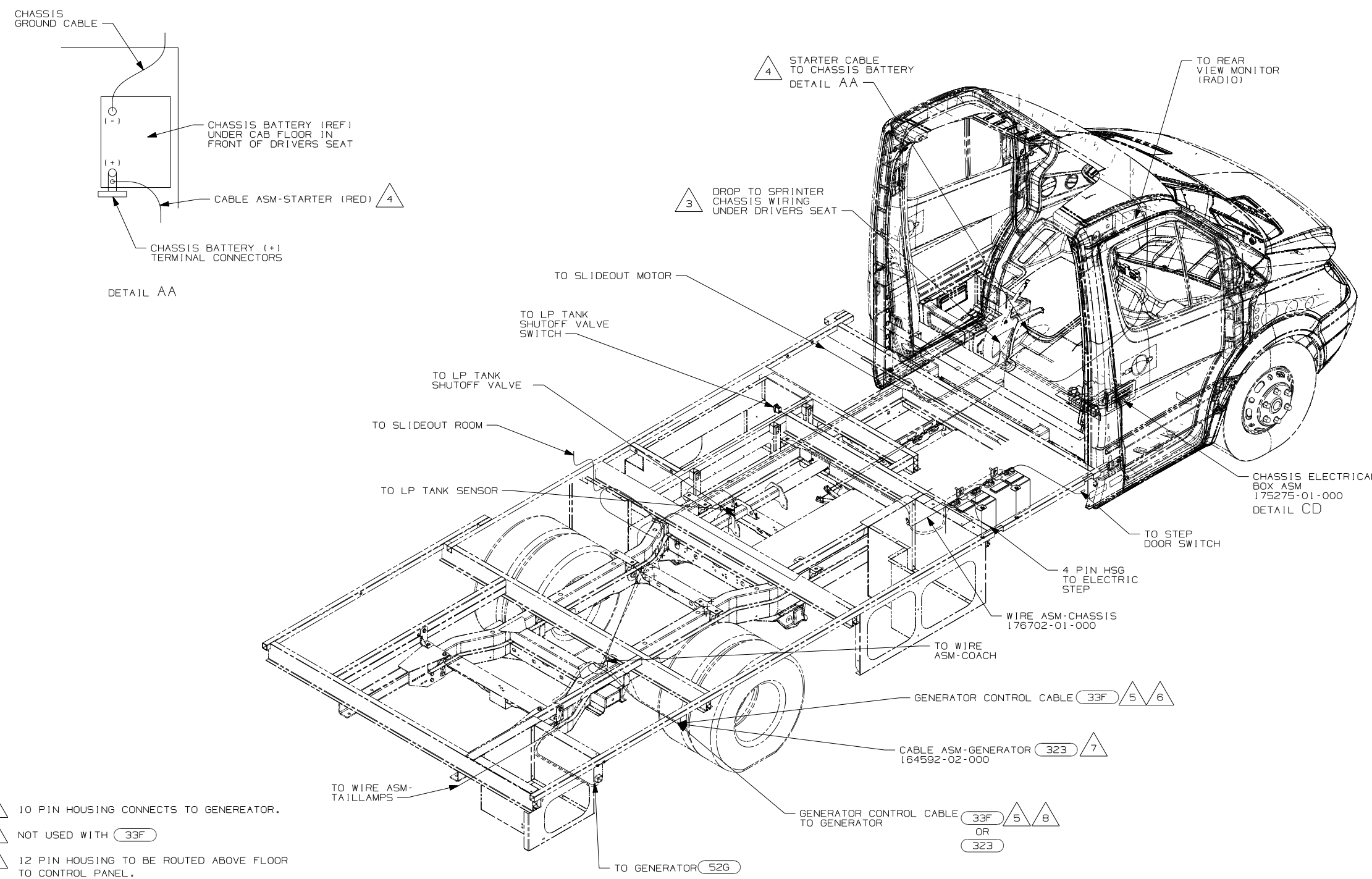

- 8 10 PIN HOUSING CONNECTS TO GENERATOR.
- 7 NOT USED WITH 33F
- 6 12 PIN HOUSING TO BE ROUTED ABOVE FLOOR TO CONTROL PANEL.
- 5 WITH FEATURE 33F CABLE IS SUPPLIED WITH GENERATOR.
- 4 SEE BATTERY INSTL FOR ADDITIONAL INFORMATION.
- 3 CUT WIRE TIE AROUND SPRINTER SEAL, ROUTE THE CHASSIS WIRING THROUGH HOLE AND WIRE TIE SEAL WITH WIRE TIE 8343-04-000.

2. SECURE CONDUIT 41953, TAB AS REQUIRED, OVER ALL WIRES IN CONTACT WITH SHARP EDGES.

1. LEGEND: — WINNEBAGO: - - - - - CABLE: - - - - - CHASSIS SUPPLIED WIRING.

- 323 GENERATOR PREP KIT - DIESEL
- 33F GEN-3.5 KW ONAN DIESEL
- 526 GEN-3.6KW ONAN LP MICROQUIET
- 1MD MERCEDES-11,030# GVWR,DIESEL
- 265 CODES/STANDARDS-CSA/CMVSS
- 1B1 CODES/STANDARDS USA

WINNEBAGO		COPYRIGHT 2010 WINNEBAGO INDUSTRIES, INC.	
DFTR	ORIG. DATE		
CHKR	ALL DIMENSIONS ARE IN MILLIMETERS		
P.E.	FIRST USED	11 524J	
M.E.			
DSNR			
UNSPECIFIED TOLERANCES ARE:		MATERIAL:	
WHOLE DIM (X)	: 3		
ONE-PLACE (X.X)	: 1.5		
TWO-PLACE (X.XX)	: 0.50		
ANGLE	: 1°		
THIRD ANGLE PROJECTION		DO NOT SCALE DRAWING	
TITLE: WIRING INSTL-CHASSIS			
SHEET 1 of 3	PART NO	176435	REV
REF:	1 4/19/2010		

FOR ELECTRICAL TORQUE SPECIFICATIONS SEE DWG NO. 128783-01-000

(X-X)

FOR ELECTRICAL CALLOUTS SEE DWG NO. 121339-01-000

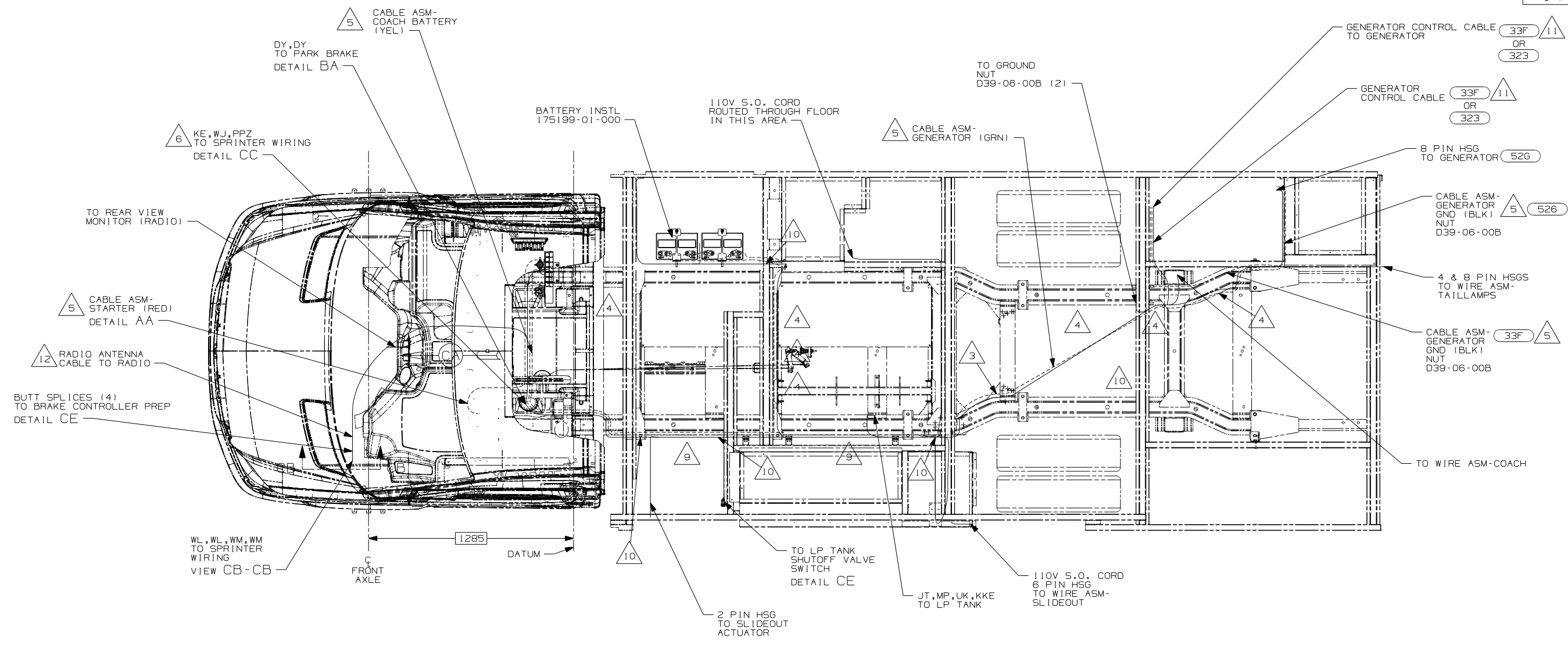

- △12 SEE ANTENNA INSTL FOR ADDITIONAL INFORMATION.
- △11 WITH FEATURE (33F) CABLE SUPPLIED WITH DIESEL GENERATOR.
- △10 TIE-WIRE MOUNT 116673-01-000. USE HOLES IN BODY MOUNTS.
- △9 TIE-WIRE MOUNT 116673-01-000. USE HOLES IN SLIDEOUT MOUNTING TRAY.
- △8 CUT BROWN/BLACK WIRE FROM PARK BRAKE SWITCH AND RECONNECT TO CIRCUIT DY OF WIRE ASM-CHASSIS AS SHOWN.
- △7 SEE WIRING INSTL-BODY,12V FOR ADDITIONAL INFORMATION.
- △6 ROUTE WIRES THROUGH CAB FLOOR UNDER DRIVERS SEAT PEDESTAL.
- △5 SEE BATTERY INSTL FOR ADDITIONAL INFORMATION.
- △4 CLAMP 83610-02-000, SCREW G39-08-12B. DO NOT DRILL OR SCREW INTO SPRINTER FRAME. USE ALUMINUM RISERS.
- △3 TIE WIRE MOUNT WIRE TIE TO CHASSIS CROSS MEMBER.

2. SECURE CONDUIT 41953, TAB AS REQUIRED, OVER ALL WIRES IN CONTACT WITH SHARP EDGES.

1. LEGEND: — WINNEBAGO: - - - - - CABLE: - - - - - CHASSIS SUPPLIED WIRING.

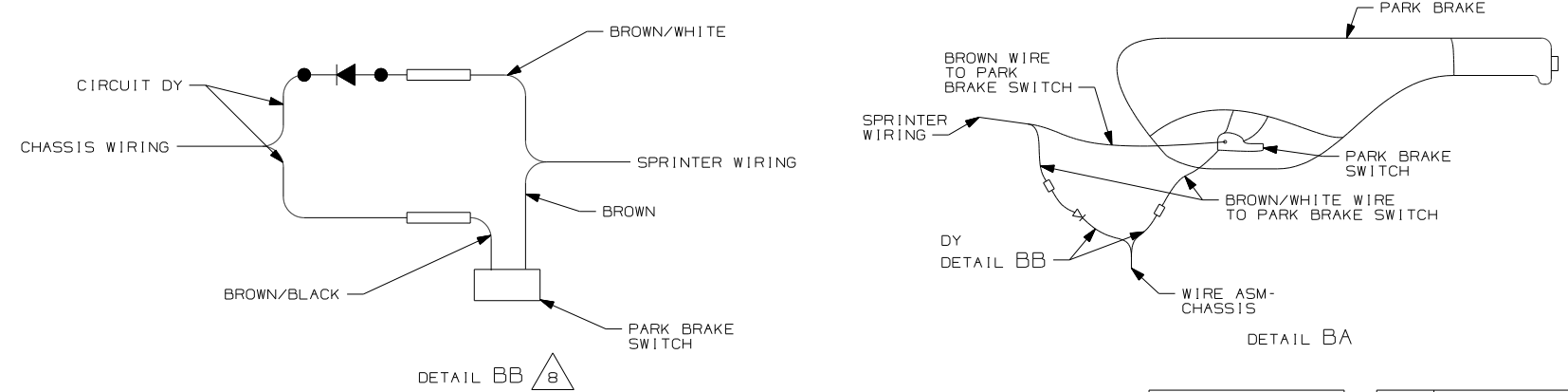

- (323) GENERATOR PREP KIT - DIESEL
- (33F) GEN-3.5 KW ONAN DIESEL
- (526) GEN-3.6KW ONAN LP MICROQUIET
- (1MD) MERCEDES-11,030# GVWR,DIESEL
- (265) CODES/STANDARDS-CSA/CMVSS
- (1B1) CODES/STANDARDS USA

FOR ELECTRICAL TORQUE SPECIFICATIONS SEE DWG NO. 128783-01-000

X-X FOR ELECTRICAL CALLOUTS SEE DWG NO. 121339-01-000

FIRST USED	11 524J	
TITLE	DO NOT SCALE DRAWING	
	WIRING INSTL-CHASSIS	
SHEET 2	PART NO	176435
	REV	

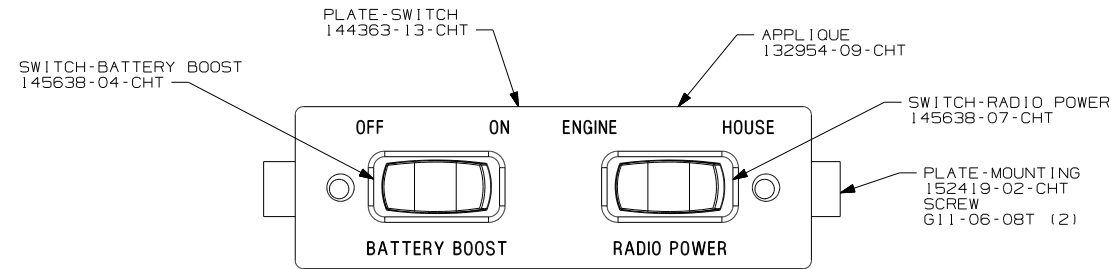

DETAIL CA

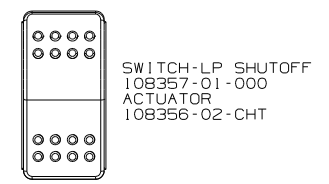

DETAIL CE

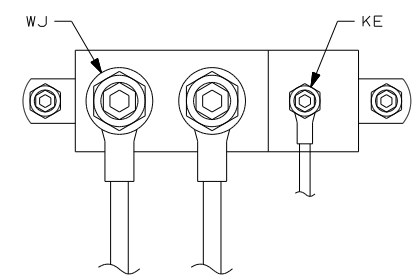

DETAIL CC 3

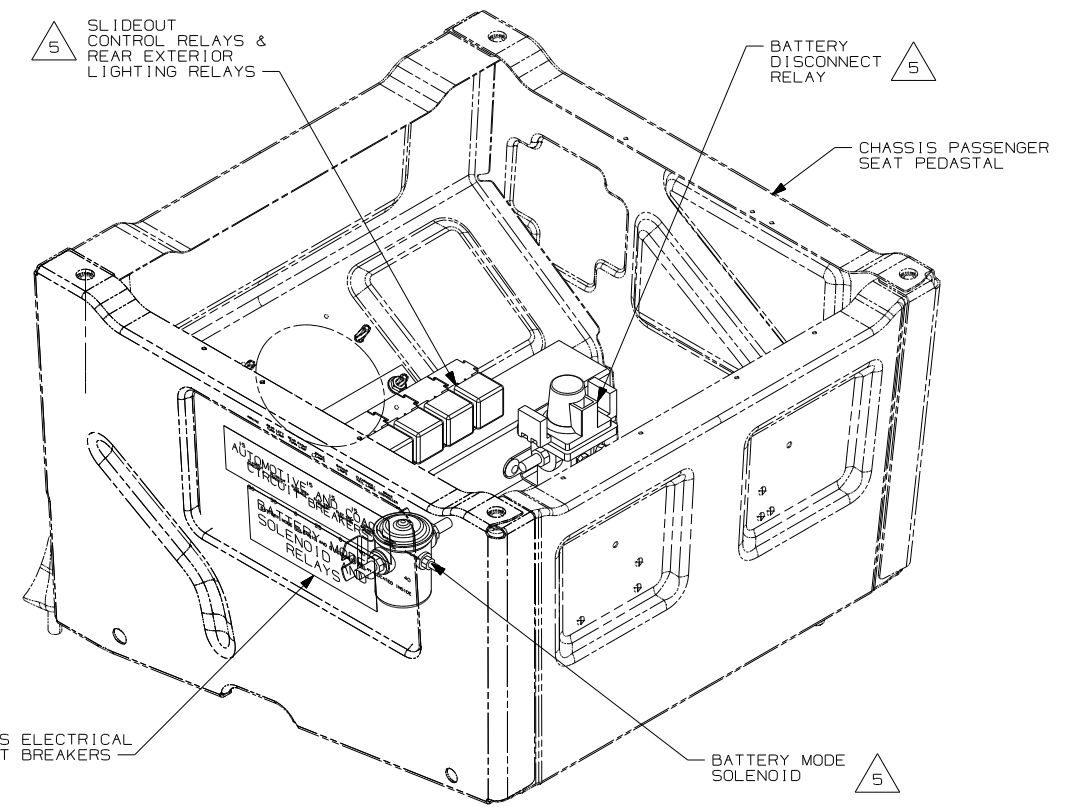

DETAIL CD

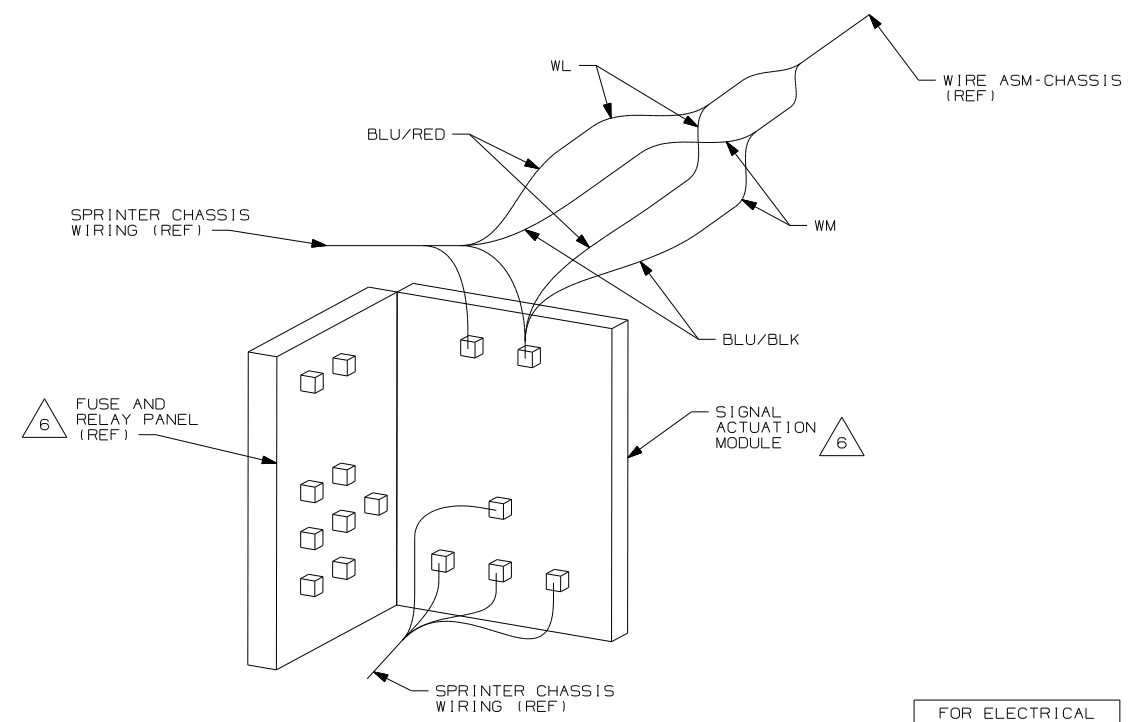

SECTION CB-CB

- 6 LOCATED IN DRIVERS SIDE KICKER PANEL.
- 5 SEE CHASSIS ELECTRICAL BOX ASM FOR ADDITIONAL INFORMATION.
- 4 REMOVE 30MM PLUG IN FIREWALL UNDER DASH. ROUTE WIRE ASM-CHASSIS FROM ENGINE COMPARTMENT THROUGH FIREWALL INTO CAB.
- 3 CONNECTION POINT IS LOCATED UNDER DRIVERS SEAT.

2. SECURE CONDUIT 41953, TAB AS REQUIRED, OVER ALL WIRES IN CONTACT WITH SHARP EDGES.

1. LEGEND: — WINNEBAGO: - - - - - CABLE: - - - - - CHASSIS SUPPLIED WIRING.

NOTES:

- 1MD MERCEDES-11,030# GVWR, DIESEL
- 265 CODES/STANDARDS-CSA/CMVSS
- 1B1 CODES/STANDARDS USA

FIRST USED	11 524J
TITLE	DO NOT SCALE DRAWING
TITLE	WIRING INSTL-CHASSIS
SHEET 3	PART NO 176435 REV

FOR ELECTRICAL TORQUE SPECIFICATIONS SEE DWG NO. 128783-01-000

X-X FOR ELECTRICAL CALLOUTS SEE DWG NO. 121339-01-000