

DWG NO	MODEL	DETAILS, SECTIONS
177072-01	231N	N
177072-02	231NP	P, R

RELEASE	REV DATE	DWG NO
A		177072
REV ZONE	REVISION RECORD	DATE
		DFTR-016

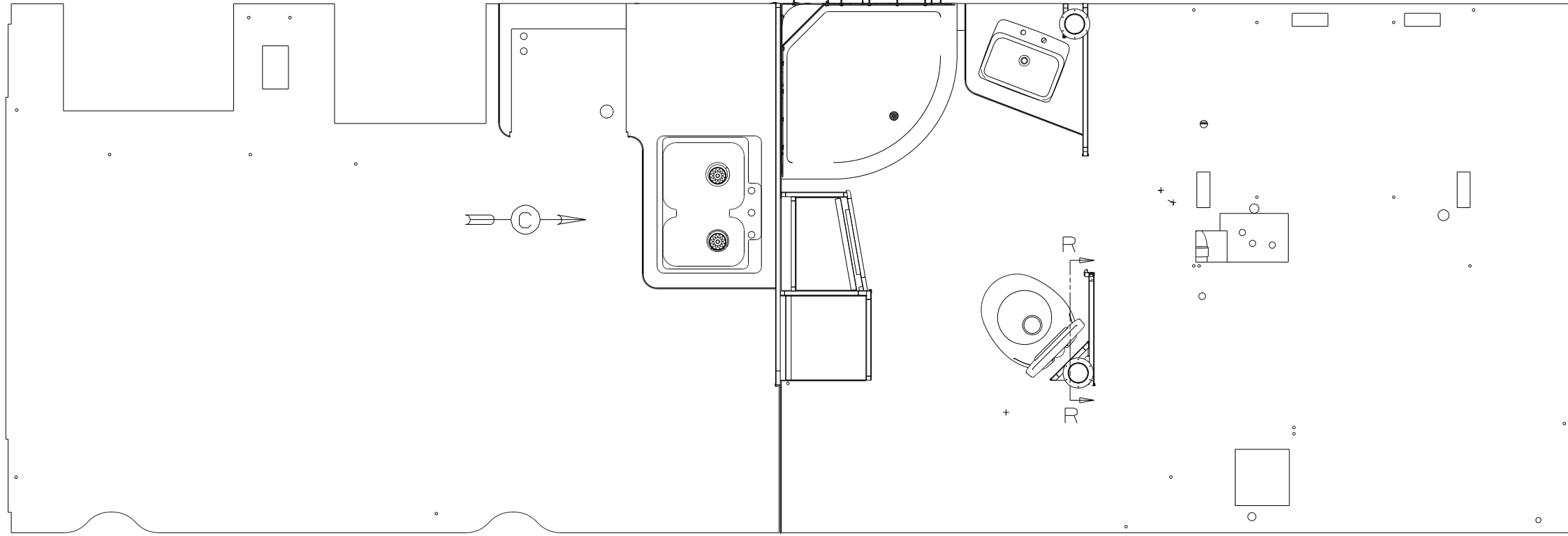

- NOTES:
10. USE SMOOTH PLUMBERS PUTTY 167459-01-000 TO SEAL STRAINER (0.2 PER STRAINER).
 9. PREP THE SURFACE PER MANUFACTURERS INSTRUCTIONS BEFORE APPLYING THE HEATING PAD.
 8. SECURE PIPES TO CABINET USING WIRE TIE 108046-02-000 AND SCREW G67-10-12B.
 7. SECURE VENT TUBES TO FLOOR WITH CLAMP 62401-02-000 (2), SCREW G67-10-12B (2), AND BRACKET 136878-01-CHT (2).
 6. VENT PIPE MUST PROJECT 51 MIN AND 64 MAX ABOVE ROOF FOR PROPER FIT AND FUNCTION.
 5. SEAL AROUND SHOWER WITH SILICONE.
 4. SEE WIRING INSTL-BODY, 12V FOR ELECTRICAL CONNECTION.
 3. ALL PIPE AND FITTINGS TO BE ASSEMBLED WITH SOLVENT 4020-01-000 (USA), 4020-02-000 (CAN)
 2. SLOPE OF TRAP ARM MUST BE 6 PER 305 mm.
 1. SLOPE OF HORIZONTAL PIPING TO BE MIN 3 PER 305 mm.

- (644) GREAT ALASKAN RENTAL PACKAGE
- (1B1) CODES/STANDARDS-USA
- (265) CODES/STANDARDS-CSA/CMVSS
- (23T) DRAINAGE SYSTEM-HEATED

WINNEBAGO		COPYRIGHT 2010 WINNEBAGO INDUSTRIES, INC.	
DFTR	ORIG. DATE	ALL DIMENSIONS ARE IN MILLIMETERS	
CHKR		FIRST USED	
P.E.		11 231N	
M.E.		UNSPECIFIED TOLERANCES ARE:	
DSNR		MATERIAL:	
		WHOLE DIM (X)	: 3
		ONE-PLACE (X.X)	: 1.5
		TWO-PLACE (X.XX)	: 0.50
		ANGLE	: 1°
		THIRD ANGLE PROJECTION	
DO NOT SCALE DRAWING		REFER TO ES0018 FOR FASTENER TIGHTENING GUIDELINES	
TITLE: DRAINAGE SYSTEM INSTL			
SHEET 1 OF 4	PART NO	177072	REV
REF:	12/17/2010		

(X-X)
FOR
DRAINAGE
CALLOUTS
SEE DWG NO
116229-01-000

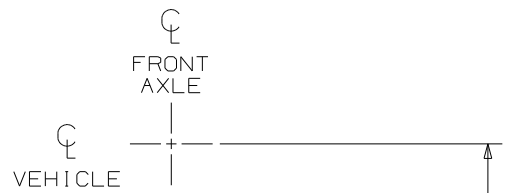

1222

DATUM

ORTHO@17
TOP VIEW
(SHOWN W/FLOOR)

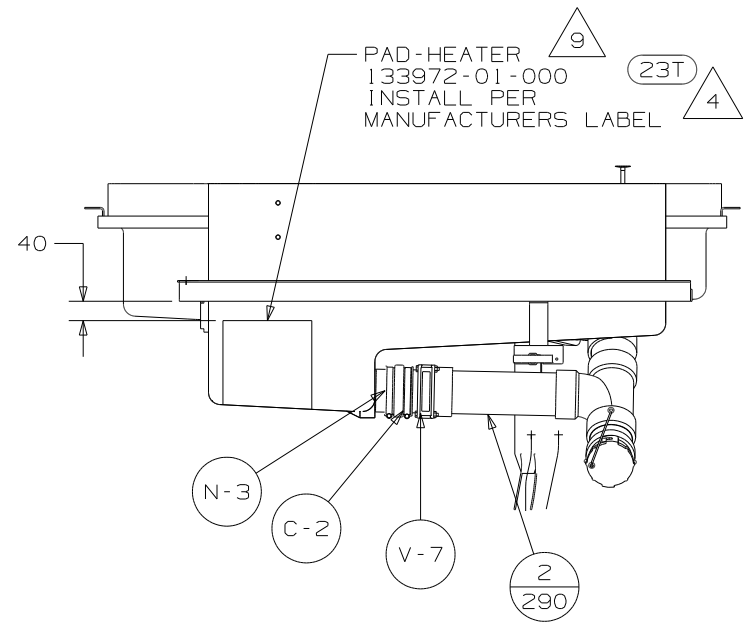
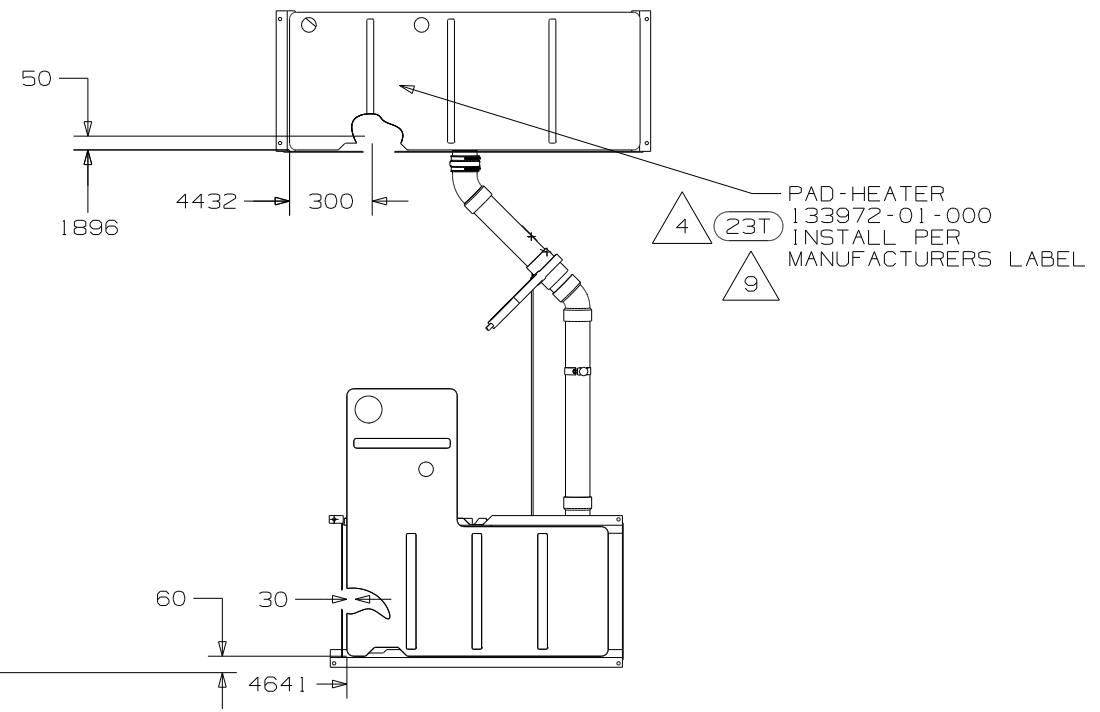

TANK - HOLDING
169281-02-CHT

CRADLE ASM
156612-04-CHT
WASHER
E13-16-00B (4)
NUT
D39-05-00B (4)

CABLE - VALVE, REMOTE
62421-11-000

HANGER - STRAP
140220-19-CHT
BOLT
C18-05-40A
NUT
D39-05-00B
HOLDER - RING
141443-05-CHT
BOLT
C26-05-16B
NUT
D39-05-00B

CRADLE ASM
156612-02-CHT
WASHER
E13-16-00B (4)
NUT
D39-05-00B (4)

TANK - HOLDING
156229-05-CHT

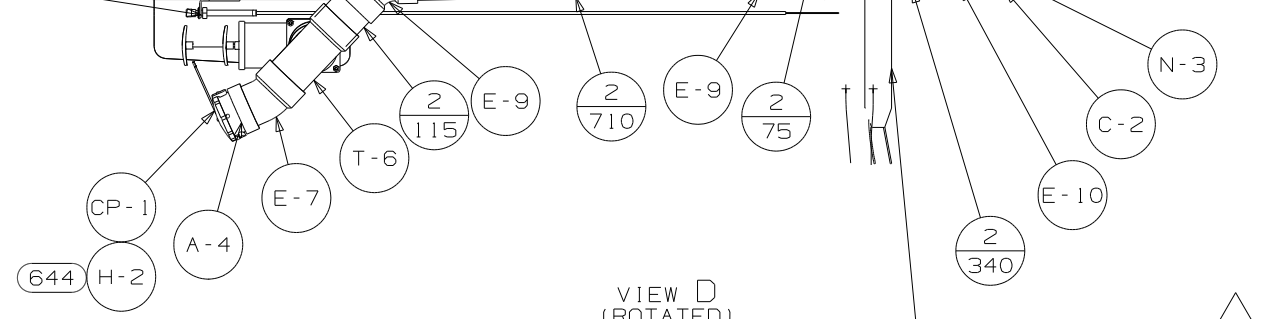

VIEW D
(ROTATED)

PAD-HEATER, ELBOW
133972-05-000

FIRST USED	11 231N
DO NOT SCALE DRAWING	
TITLE	DRAINAGE SYSTEM INSTL
SHEET 3	PART NO 177072 REV

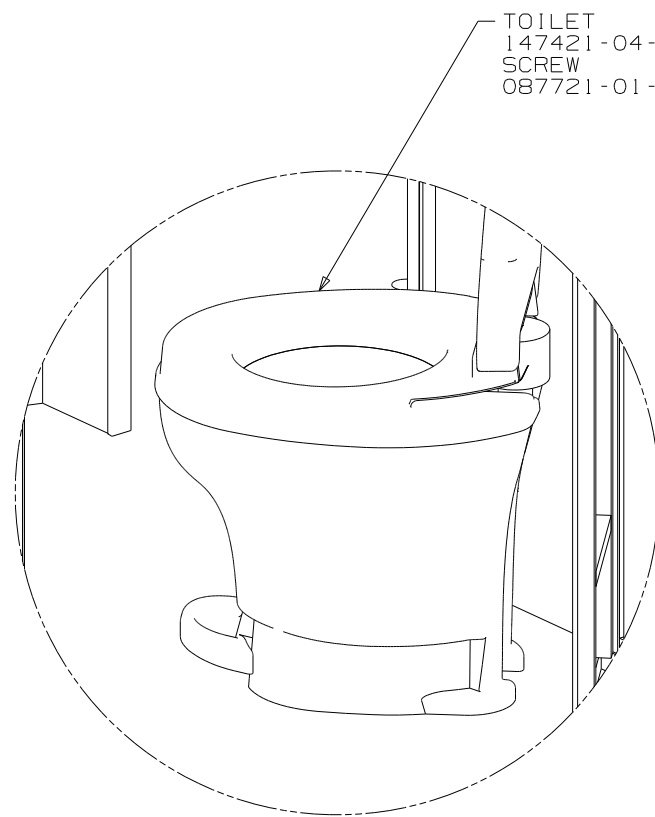

TOILET
147421-04-000
SCREW
087721-01-000 (6)

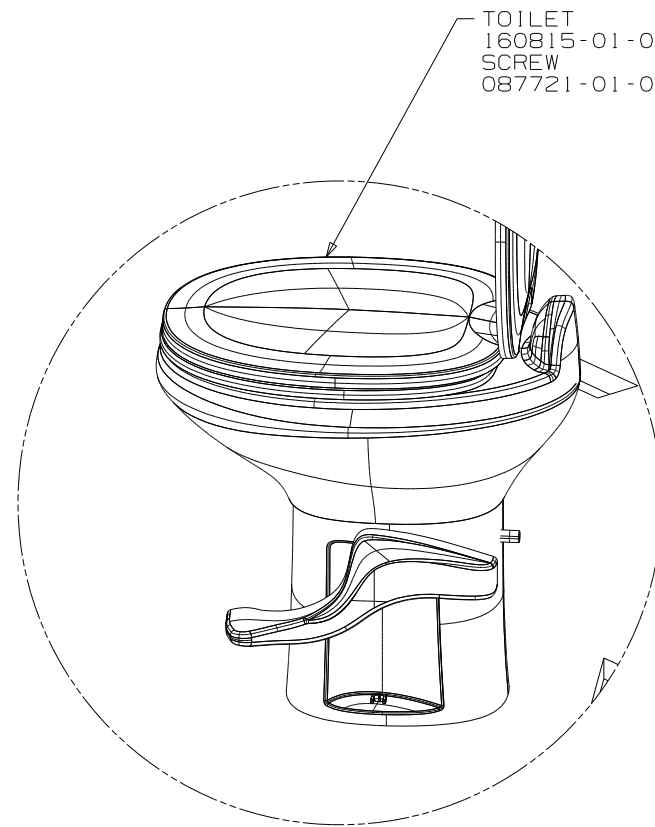

TOILET
160815-01-000
SCREW
087721-01-000 (6)

DETAIL N

DETAIL P

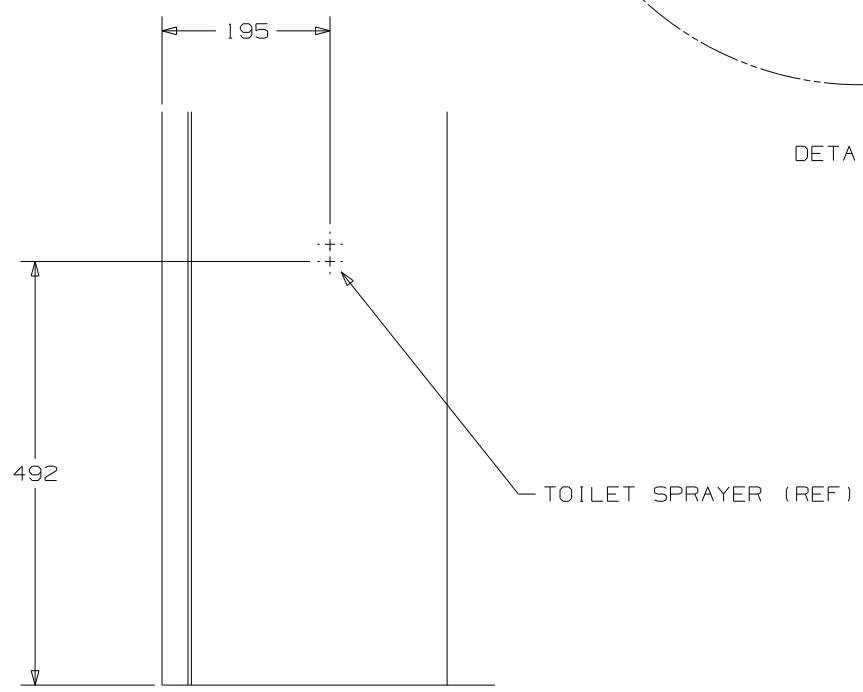

SECTION R-R

FIRST USED	11 231N
TITLE	DO NOT SCALE DRAWING DRAINAGE SYSTEM INSTL
SHEET 4	PART NO 177072 REV

DWG NO	MODEL	VIEWS OR DETAILS
177073-01	231N	P, S, A
177073-02	231NP	R, T, U, V

RELEASE	REV DATE	DWG NO
A		177073
REV ZONE	REVISION RECORD	DATE
		DFTR-0R16

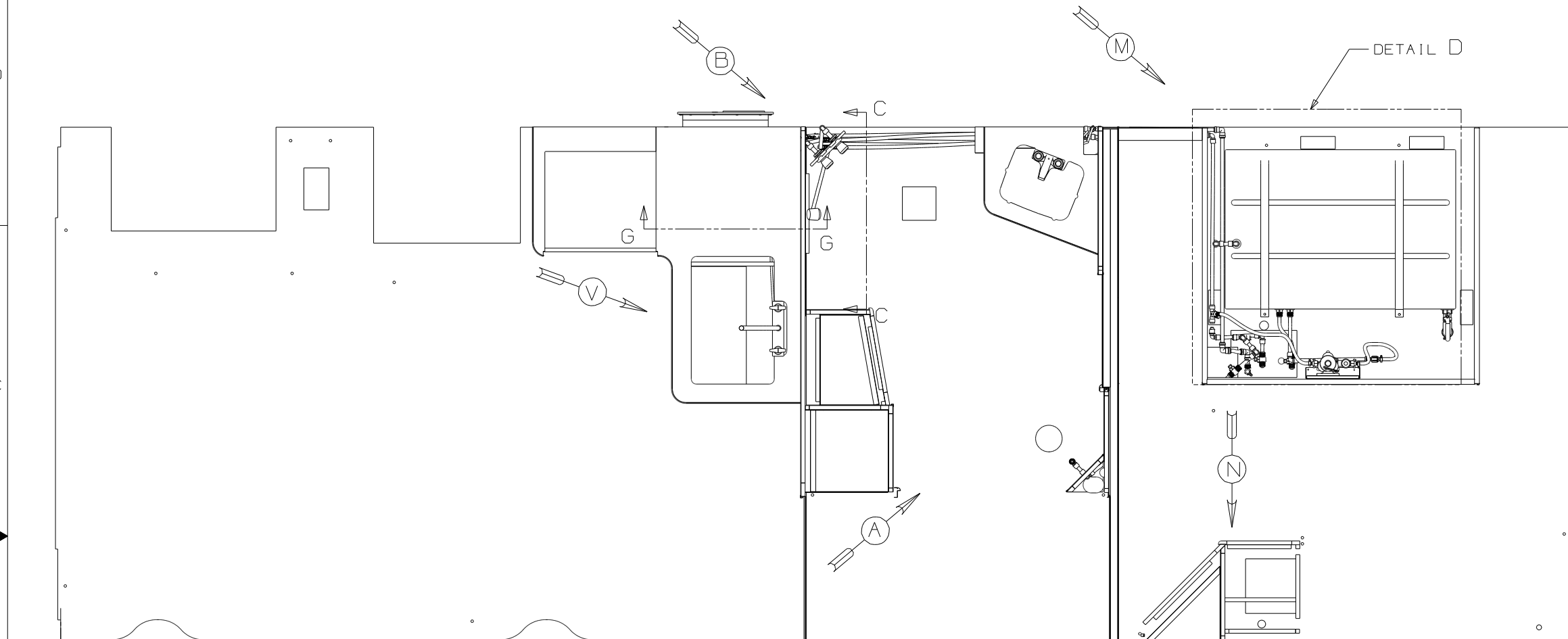

- (1J4) EXT WASH STATION - WITHOUT
- (64R) EXTERIOR WASH STATION
- (53Z) WATER HTR-6,GAS/120/IGN,REM
- (53F) WATER HEATER-ELEC. IGNITION
- (53E) WATER SYS WINTERIZATION PKG

- NOTES:
1. PLASTIC FITTINGS TO BE SEALED WITH SEALANT 084456-01-000.
 2. TUBING TO BE INSTALLED WITH SUFFICIENT SLOPE TO PROVIDE DRAINAGE TO NEAREST VALVE.
 3. ALL TUBING TO BE SECURED AT 1200 INTERVALS MAXIMUM WITH CLAMP 010495-01-000 AND SCREW 000667-10-12B OR EQUIVALENT.
 4. ADD TEFLON TAPE 010405-01-000.
 5. ADD TEFLON TAPE 010405-02-000.
 6. ADD TEFLON TAPE 010405-03-000.
 7. ADD PIPE WRAP (LADDER SCRAP 110157-02-000) INSULATION. OR USE CARPET PAD (SCRAP) 075233-06-000.
 8. USE WHEN NOT USING 53E OPTION.

FOR WATER CALLOUTS SEE DWG NO 116230-01-000

WINNEBAGO		COPYRIGHT 2011 WINNEBAGO INDUSTRIES, INC.	
DFTR	ORIG. DATE	ALL DIMENSIONS ARE IN MILLIMETERS	
CHKR		11 231N	
P.E.		UNSPECIFIED TOLERANCES ARE:	
M.E.	FIRST USED	WHOLE DIM (X)	: 3
DSNR		ONE-PLACE (X.X)	: 1.5
		TWO-PLACE (X.XX)	: 0.50
		ANGLE	: 1°
THIRD ANGLE PROJECTION		MATERIAL:	
DO NOT SCALE DRAWING		REFER TO ES0018 FOR FASTENER TIGHTENING GUIDELINES	
TITLE: WATER SYSTEM INSTL			
SHEET 1 OF 5	PART NO	177073	REV
REF:	1 3/25/2011		

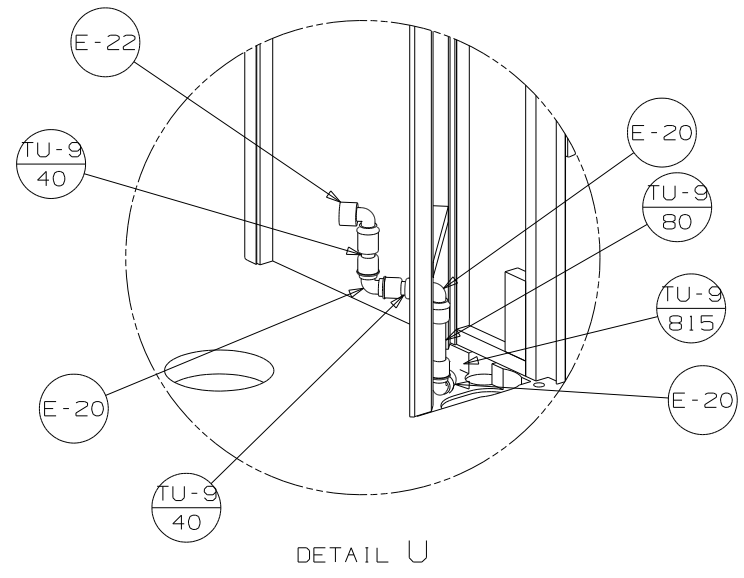

DETAIL U

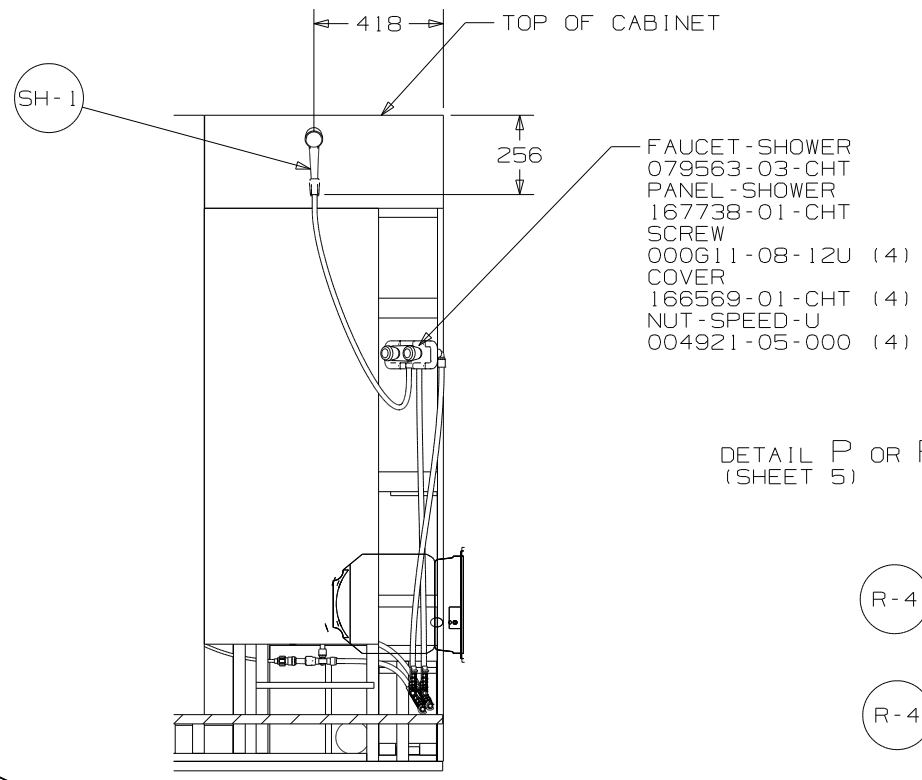

SECTION C-C (ROTATED)

- FAUCET - SHOWER 079563-03-CHT
- PANEL - SHOWER 167738-01-CHT
- SCREW 000611-08-12U (4)
- COVER 166569-01-CHT (4)
- NUT - SPEED - U 004921-05-000 (4)

DETAIL P OR R (SHEET 5)

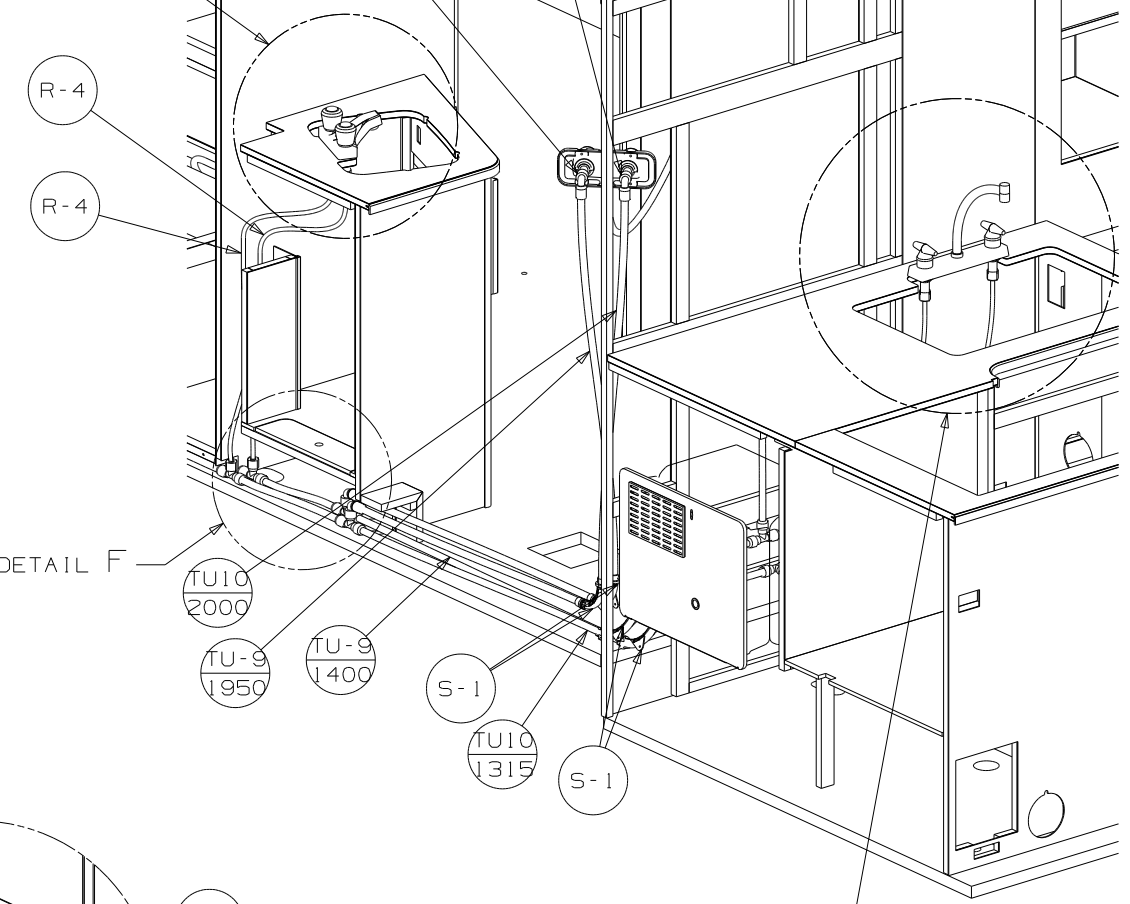

VIEW B

DETAIL S OR T (SHEET 5)

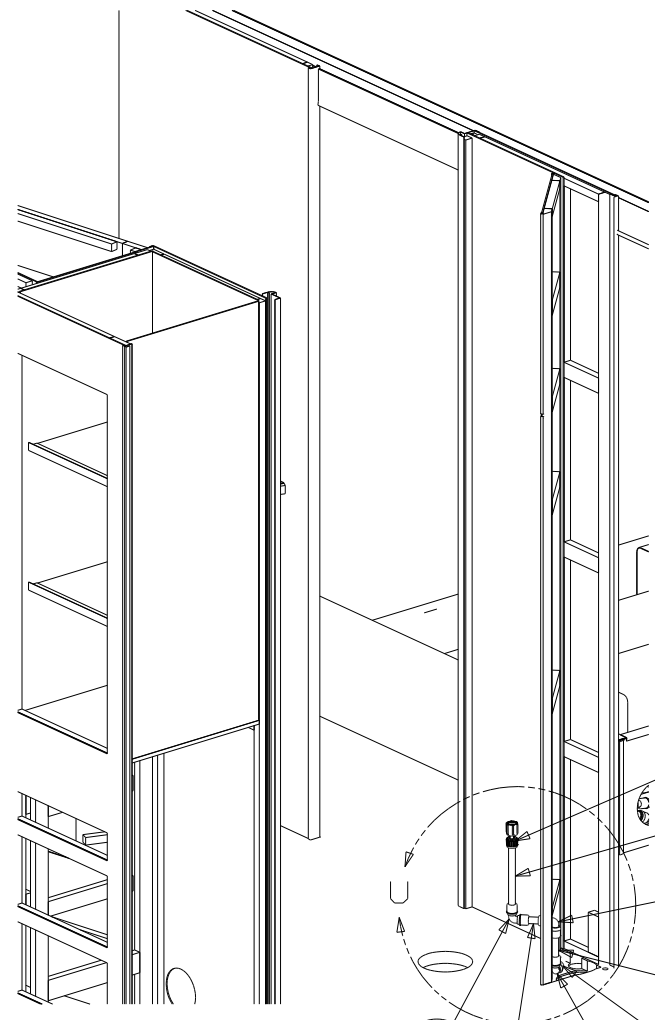

VIEW A

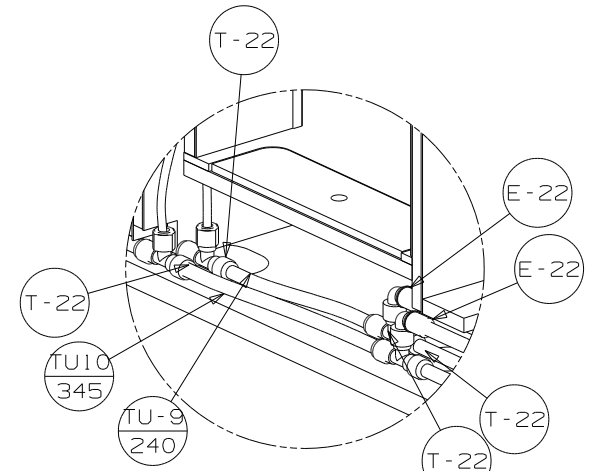

DETAIL F

FIRST USED	11 231N
DO NOT SCALE DRAWING	
TITLE:	WATER SYSTEM INSTL
SHEET 2	PART NO 177073 REV

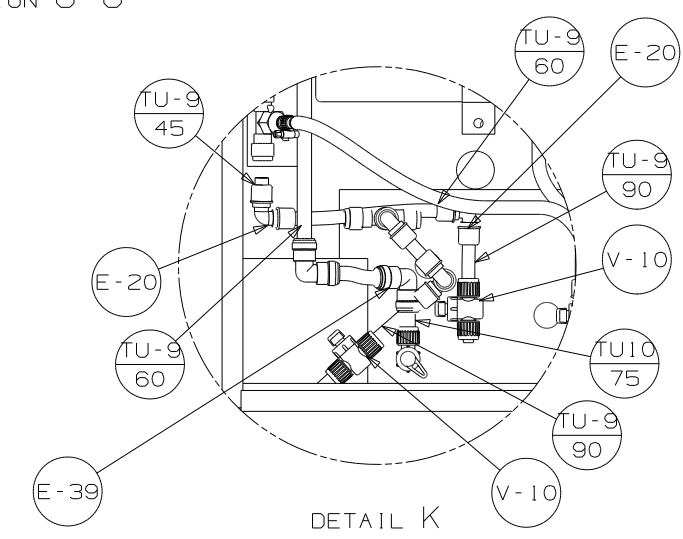
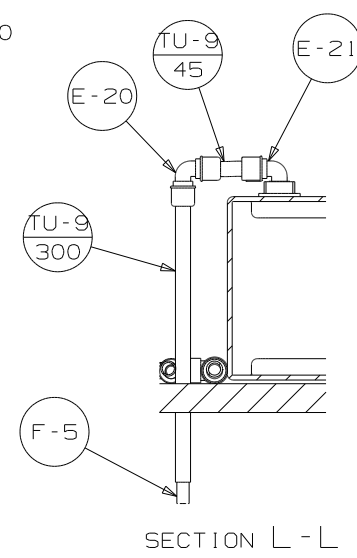
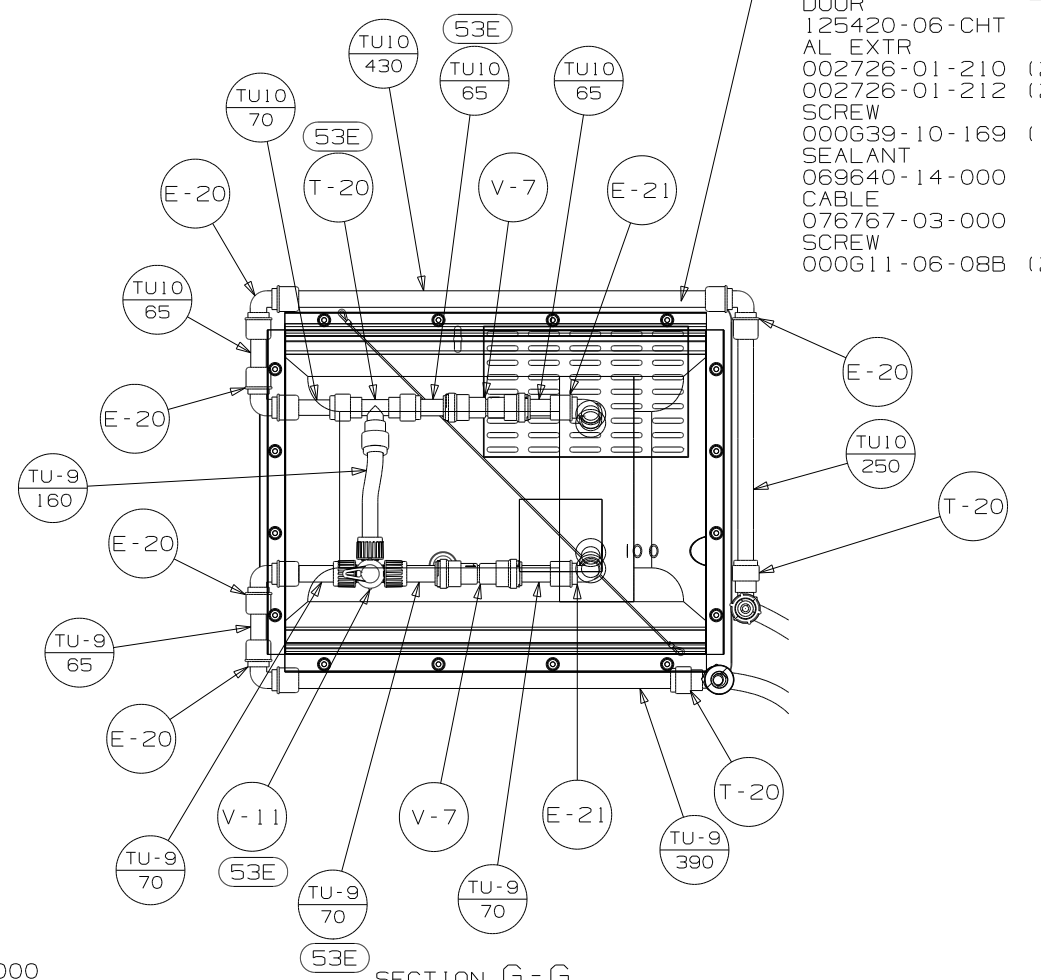
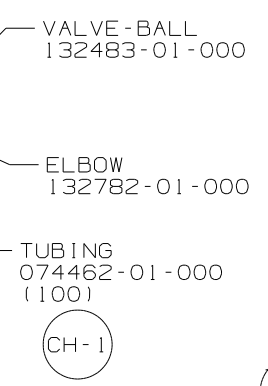
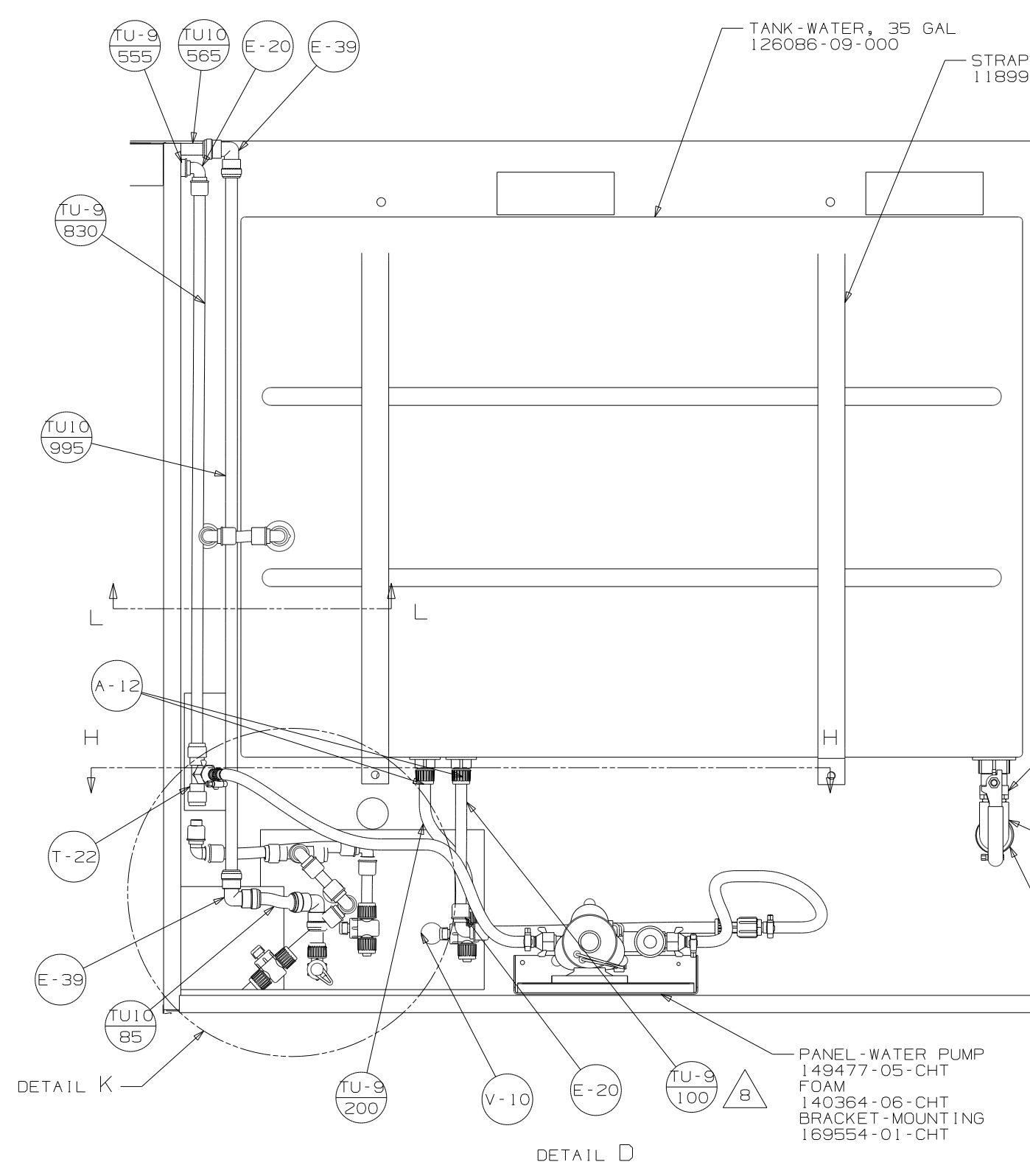

FIRST USED	11 231N	
TITLE:	DO NOT SCALE DRAWING	
TITLE:	WATER SYSTEM INSTL	
SHEET 3	PART NO	177073
	REV	

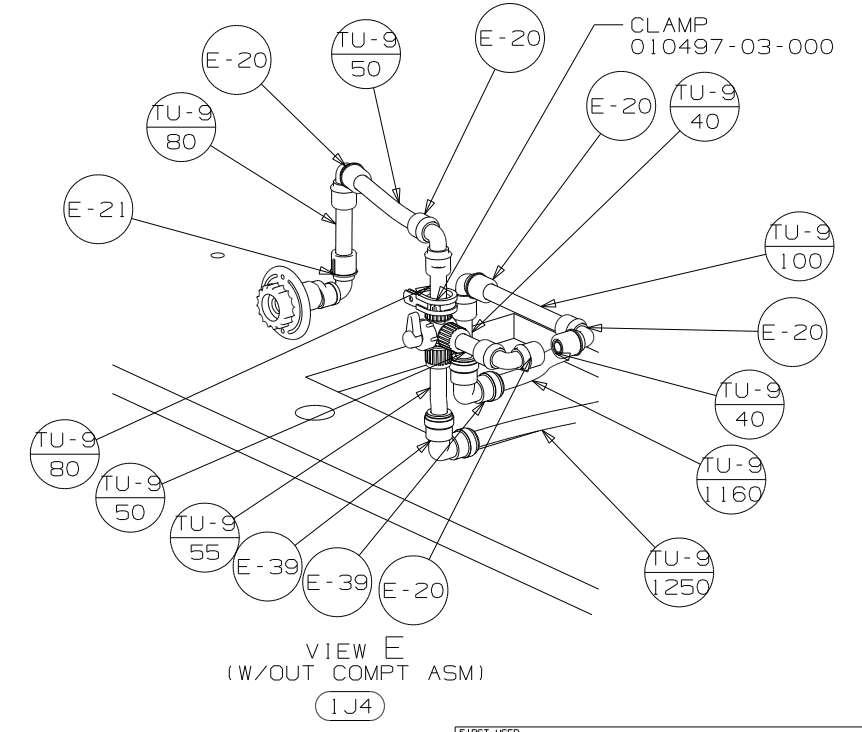
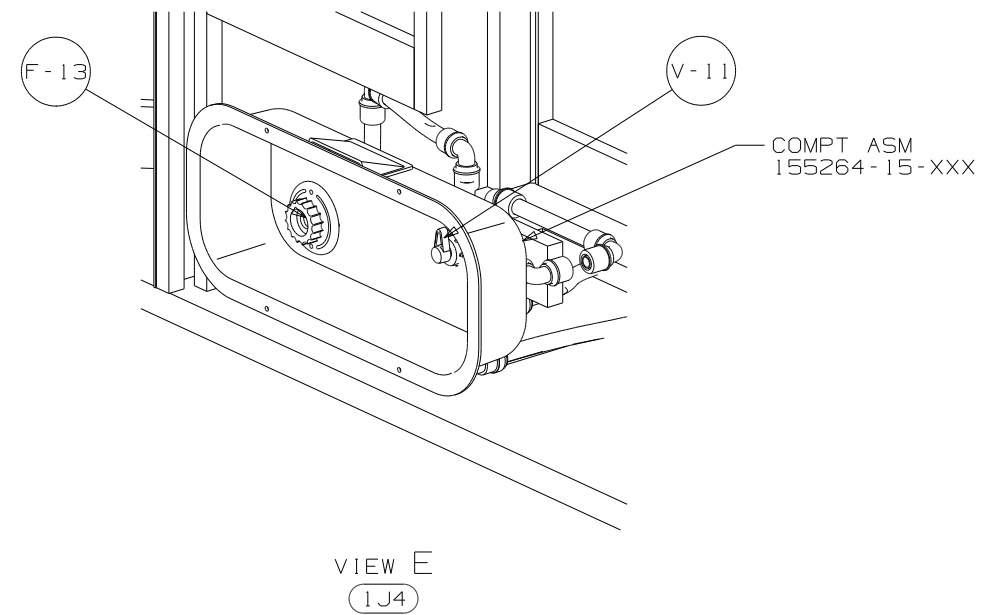
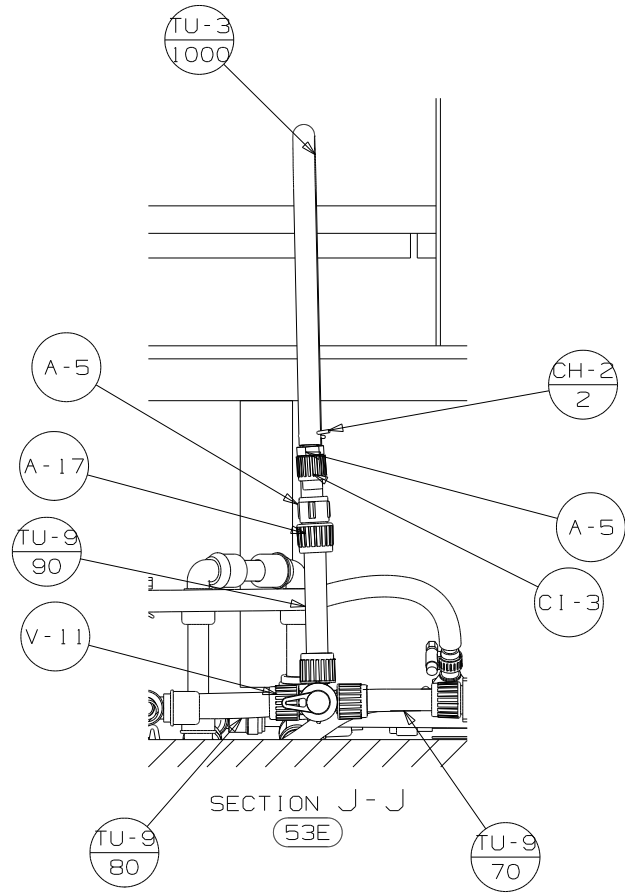
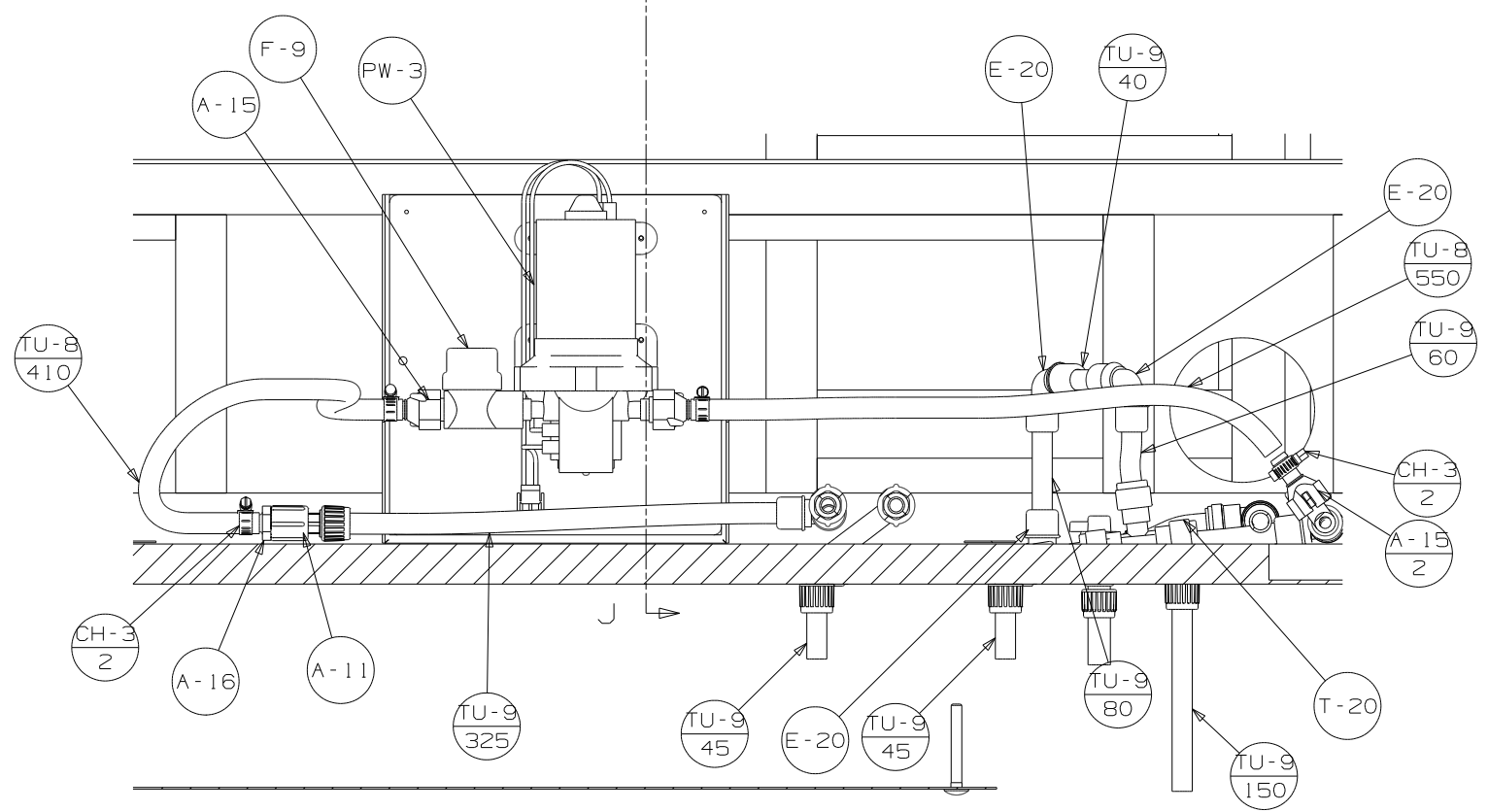

FIRST USED	11 231N
TITLE	DO NOT SCALE DRAWING
TITLE	WATER SYSTEM INSTL
SHEET 4	PART NO 177073 REV
1 3/25/2011	

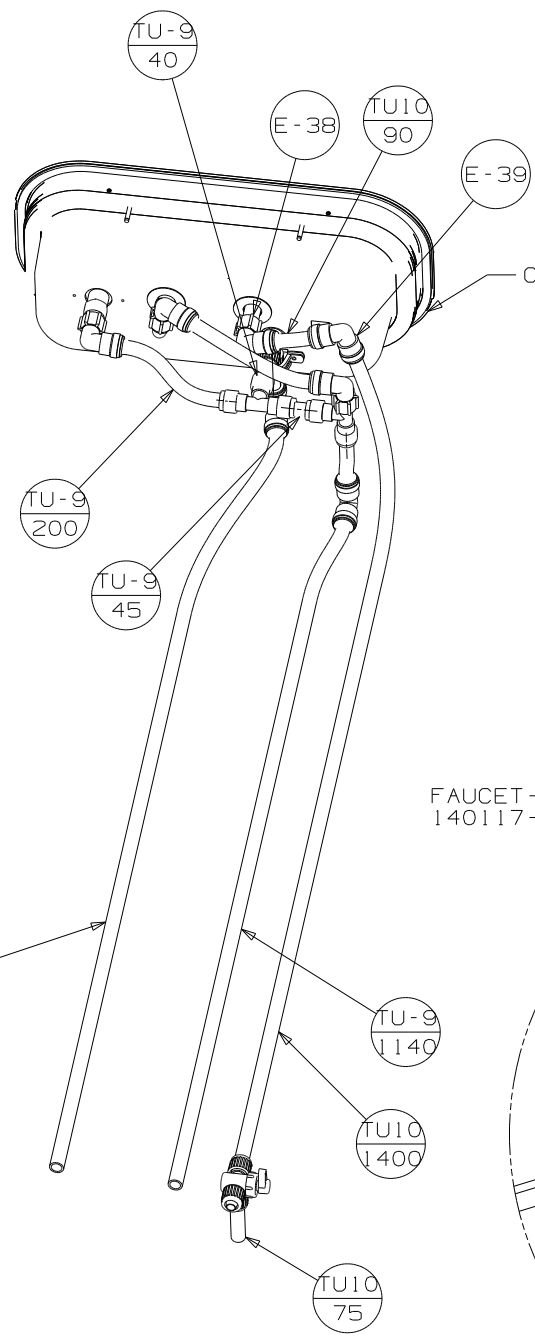

COMPARTMENT ASM
155264-04-XXX

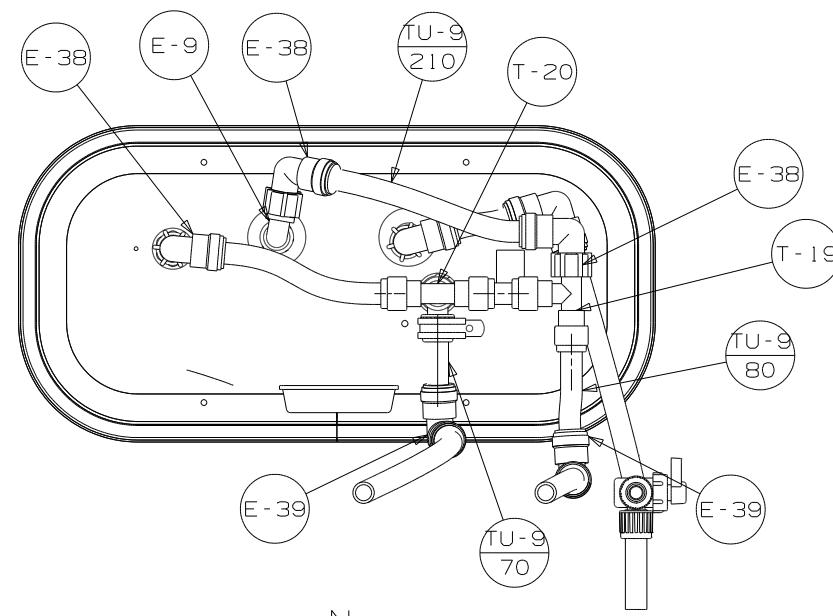

VIEW N
64R

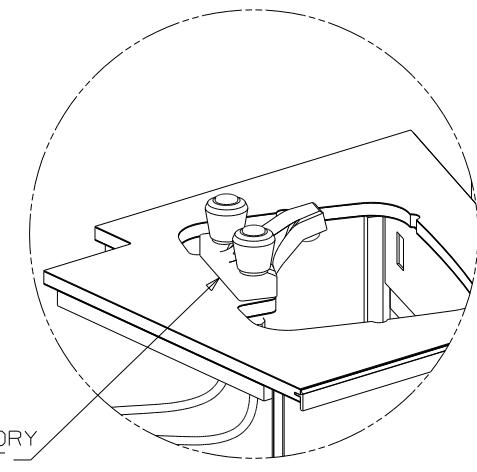

DETAIL P

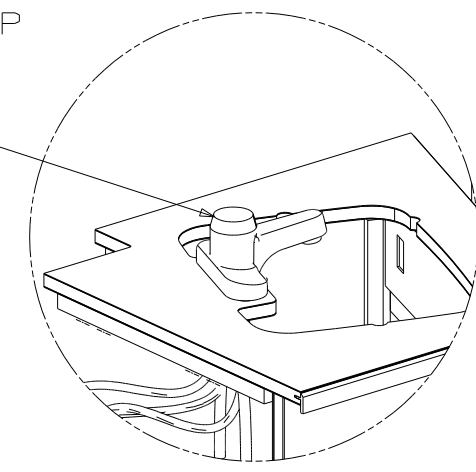

DETAIL R

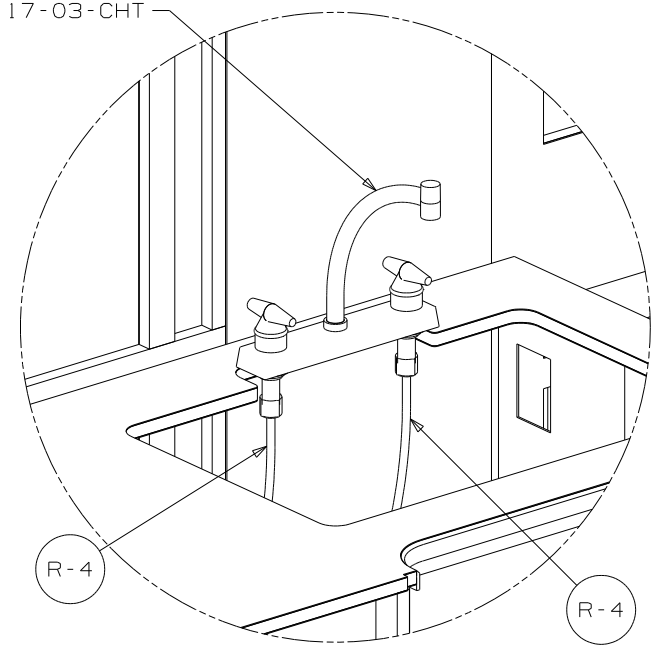

DETAIL S

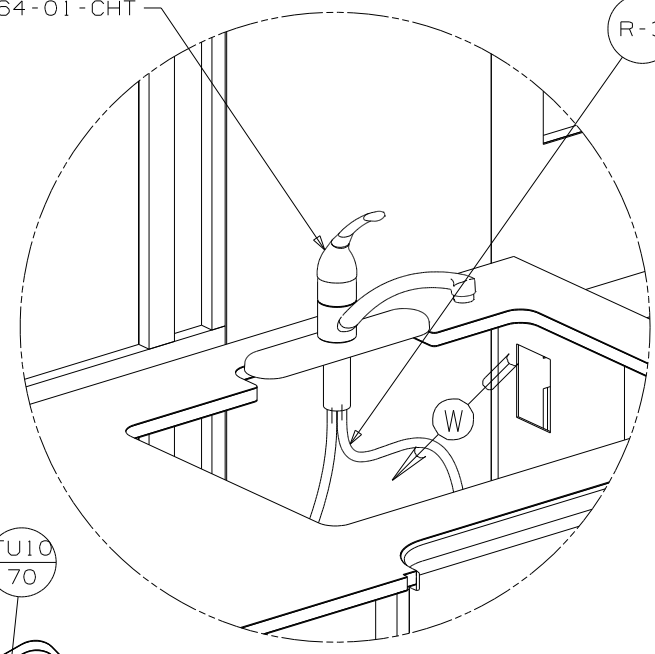

DETAIL T

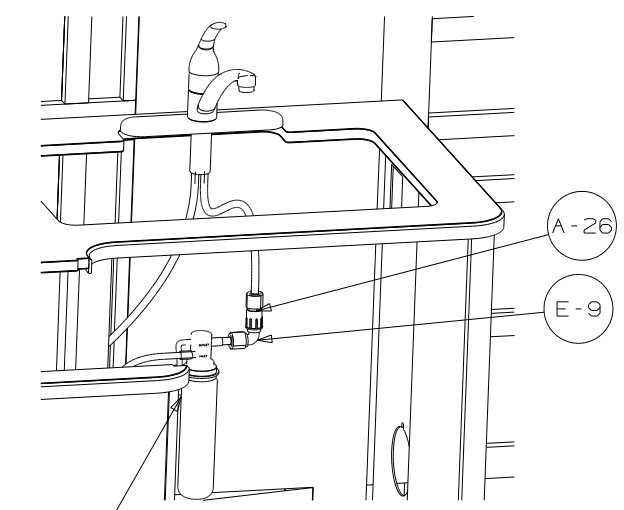

VIEW V

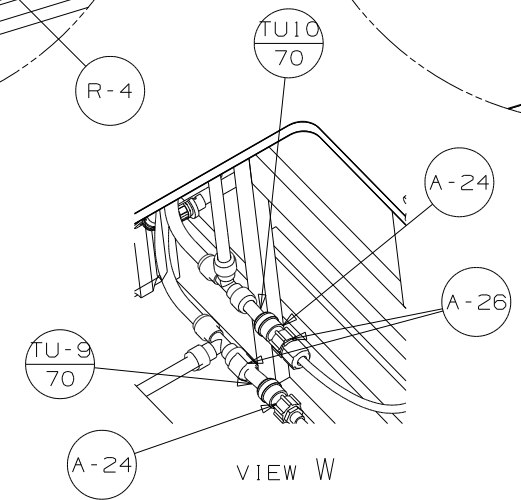

VIEW W

FILTER
160946-03-000
SCREW
000667-10-12U (2)

VIEW M
64R

FIRST USED	11 231N
TITLE	DO NOT SCALE DRAWING
TITLE	WATER SYSTEM INSTL
SHEET 5	PART NO 177073 REV