



DANGER

Danger of electrical shock, burns or death. Always remove all power sources before attempting any repair, service or diagnostic work. Power can be present from shore power, generator, inverter or battery. All power sources must be disabled and secured before performing any service.



CAUTION

If you lack the skills, tools or equipment to perform diagnostic or repair work leave such work to an authorized Winnebago Industries dealer or other qualified shop.

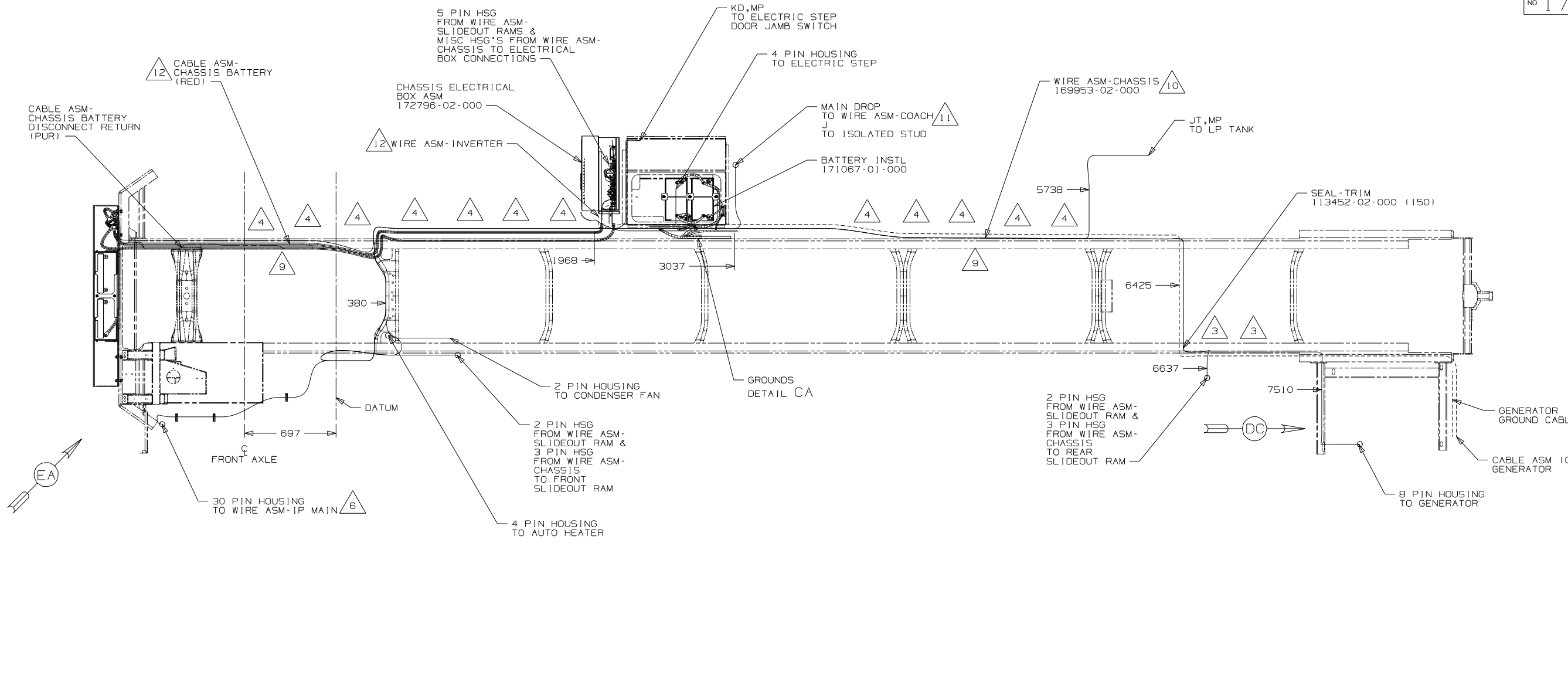

- △12 SEE BATTERY INSTL FOR ADDITIONAL INFORMATION.
- △11 SEE INSTL-BODY, 12V FOR ADDITIONAL INFORMATION.
- △10 COIL UP EXTRA WIRE AND TIE BACK TO LOOM.
- △9 SECURE SO WIRES DO NOT CONTACT EXHAUST.
- △8 ROUTE WIRES & CABLE OVER SPRING HANGER AT THIS POINT.
- △7 SUPPLIED WITH CHASSIS.
- △6 SEE WIRING INSTL-FRONT END FOR ADDITIONAL INFORMATION.
- △5 ROUTE WIRES & CABLE INSIDE CHASSIS RAIL AT THIS POINT AND TO THE REAR.
- △4 CLAMP 83610-03-000, SCREW G39-08-12B.
- △3 CLAMP 83610-01-000, SCREW G39-08-12B.

2. SECURE CONDUIT 41953-09, -10, -11, -13, AND -14 OVER ALL WIRES IN CONTACT WITH SHARP EDGES.

1. LEGEND: ——— WINNEBAGO: - - - - - CABLE: - - - - - CHASSIS SUPPLIED WIRING.

NOTES:

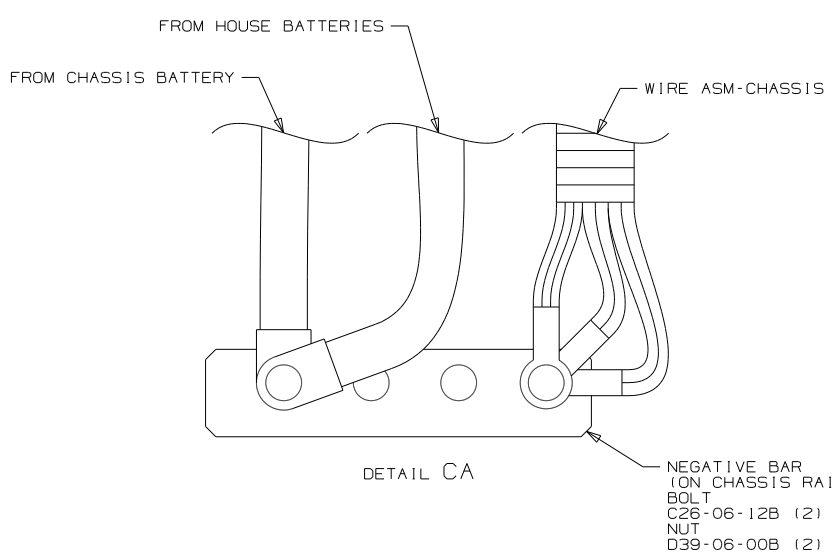

FOR ELECTRICAL TORQUE SPECIFICATIONS SEE DWG NO. 128783-01-000

FOR ELECTRICAL CALLOUTS SEE DWG NO. 121339-01-000

- ILL FRTL (FRED) 27K-300HP 22.5TIRE
- 265 CODES/STANDARDS-CSA/CMVSS
- 1B1 CODES/STANDARDS USA

FIRST USED	10 J35P
TITLE	DO NOT SCALE DRAWING
TITLE	WIRING INSTL-CHASSIS
SHEET 3	PART NO 171905 REV

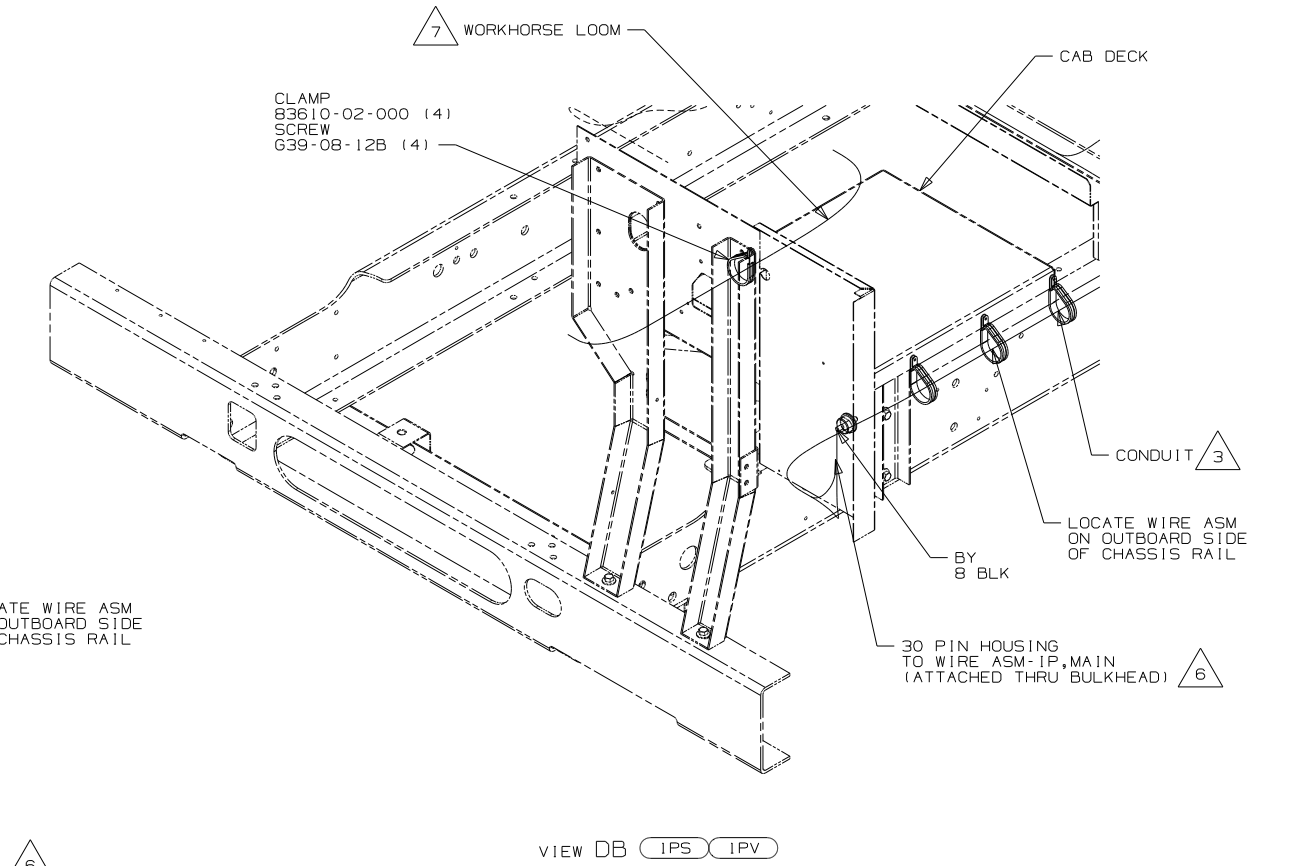
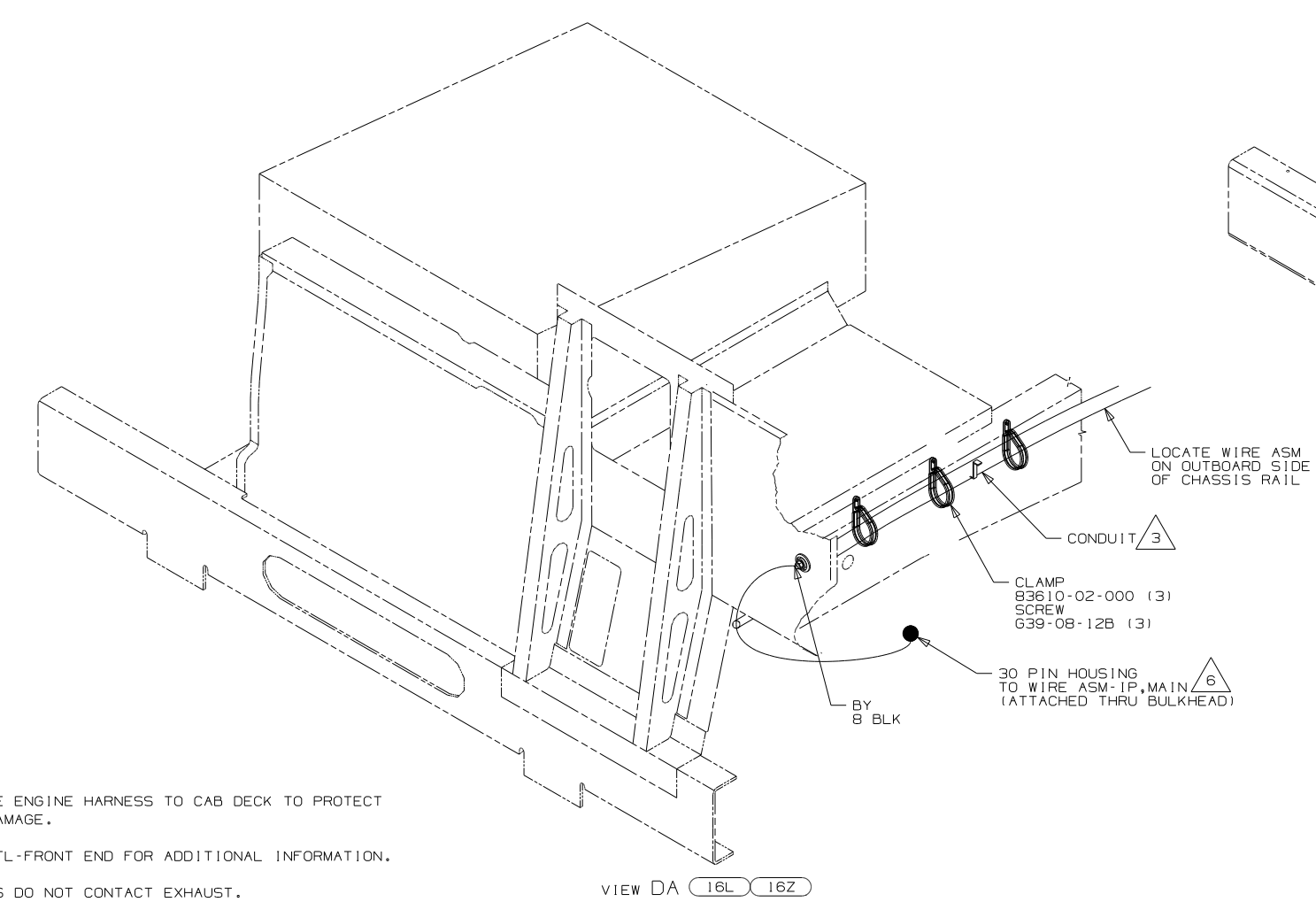
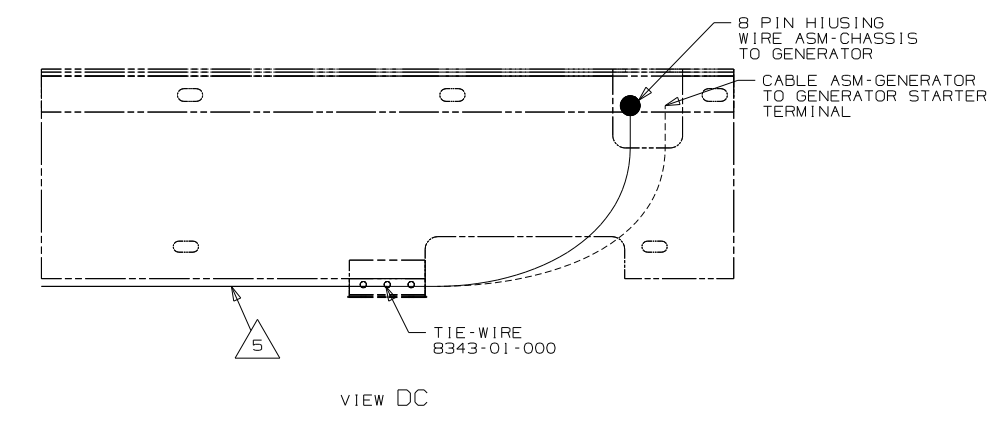
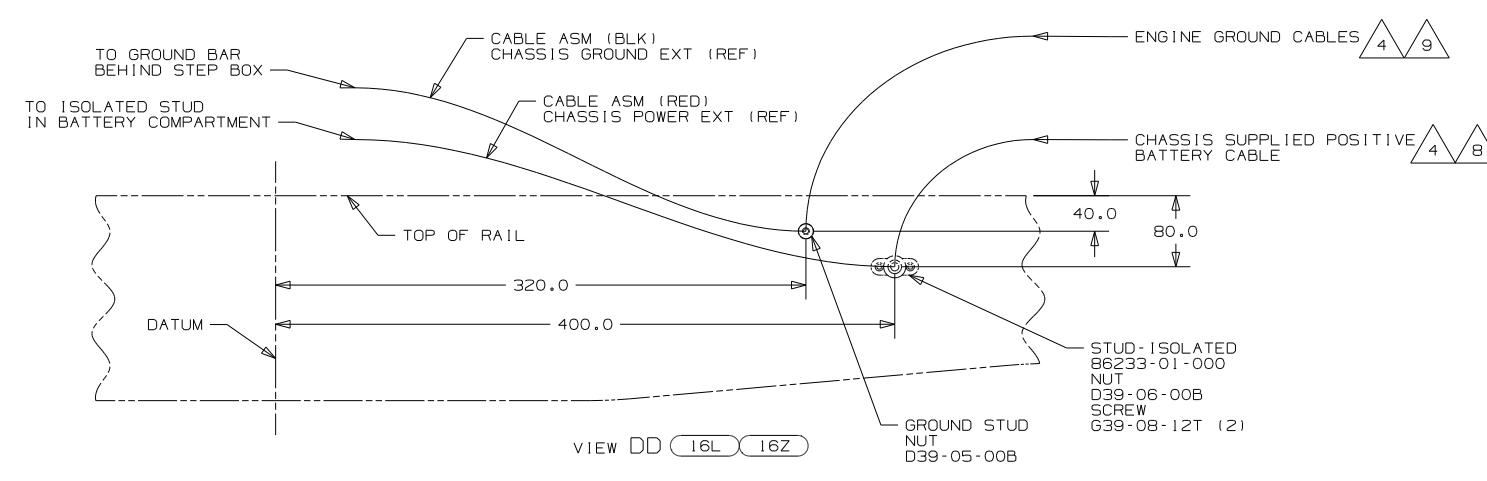

- 7 CLAMP WORKHORSE ENGINE HARNESS TO CAB DECK TO PROTECT HARNESS FROM DAMAGE.
- 6 SEE WIRING INSTL-FRONT END FOR ADDITIONAL INFORMATION.
- 5 SECURE SO WIRES DO NOT CONTACT EXHAUST.
- 4 SUPPLIED WITH CHASSIS.
- 3 COVER WITH CONDUIT 41953-10-000 AND 41953-11-000 AS REQUIRED.

- 9 CUT CHASSIS SUPPLIED BATTERY CABLE 700MM FROM BATTERY TERMINAL AND ADD TERMINAL 8348-01-000 TO CUT END
- 8 CUT CHASSIS SUPPLIED POSITIVE BATTERY CABLE 150MM FROM BATTERY TERMINAL END, DISCARD TERMINAL END AND ADD TERMINAL 113738-01-000 TO CUT END. COIL EXCESS ALONG FRAME RAIL JUST BEHIND THE RADIATOR AND TIE UP WITH WIRE-TIE 8343-04-000

2. SECURE CONDUIT 41953-09, -10, -11, -13, AND -14 OVER ALL WIRES IN CONTACT WITH SHARP EDGES.

1. LEGEND: — WINNEBAGO; - - - CABLE; - - - CHASSIS SUPPLIED WIRING.

NOTES:

FOR ELECTRICAL TORQUE SPECIFICATIONS SEE DWG NO. 128783-01-000

FOR ELECTRICAL CALLOUTS SEE DWG NO. 121339-01-000

- 1PV WORKHORSE 24,000#-22.5 TIRE
- 1PS WORKHORSE 22,000#-22.5 TIRE
- 16Z FORD 24,000#-22.5 ALUM WHEEL
- 16L FORD 22,000#-22.5 AL WHL
- 265 CODES/STANDARDS-CSA/CMVSS
- 1B1 CODES/STANDARDS USA

FIRST USED	10 J35P
DO NOT SCALE DRAWING	
TITLE:	WIRING INSTL-CHASSIS
SHEET 4	PART NO 171905 REV

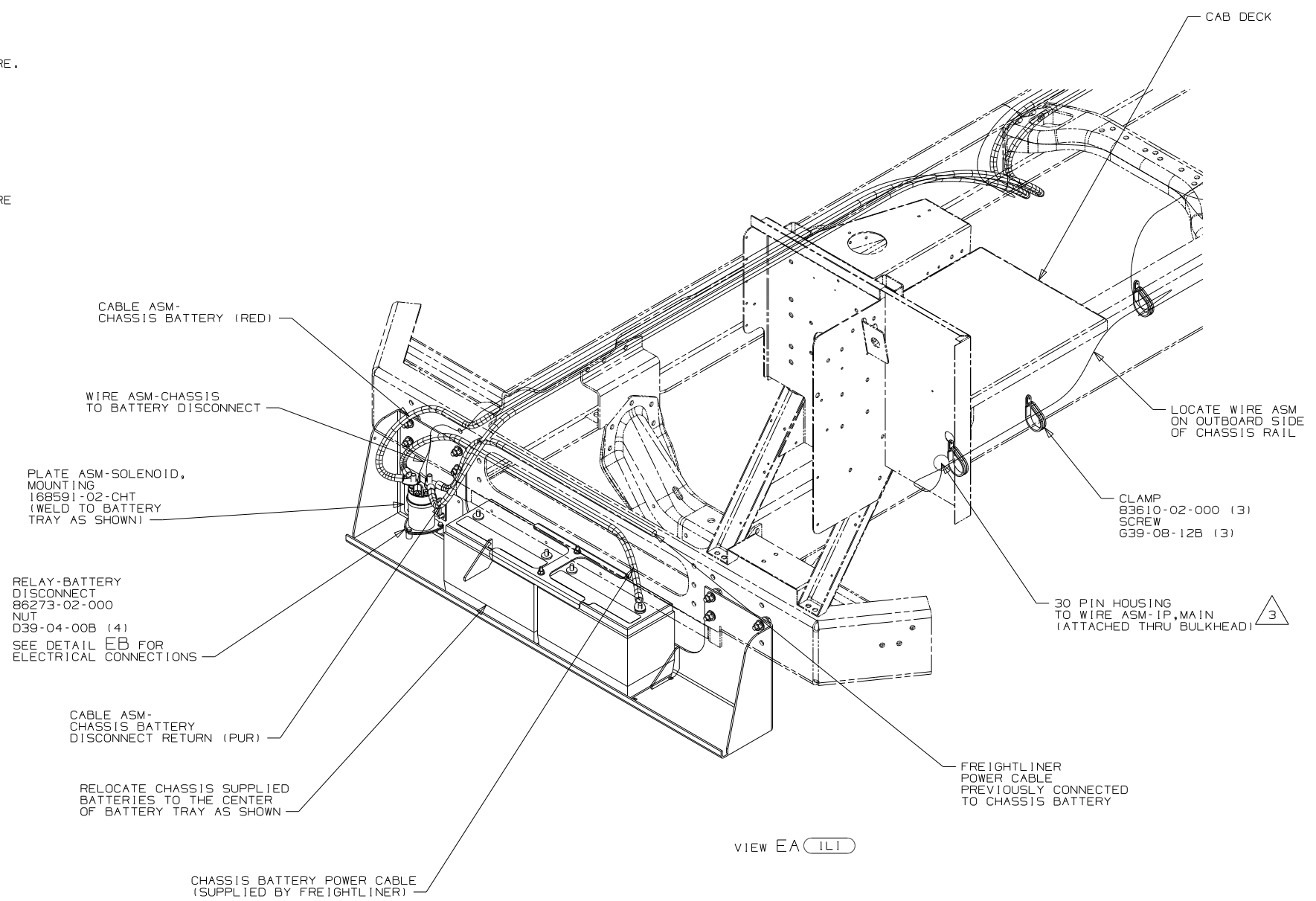
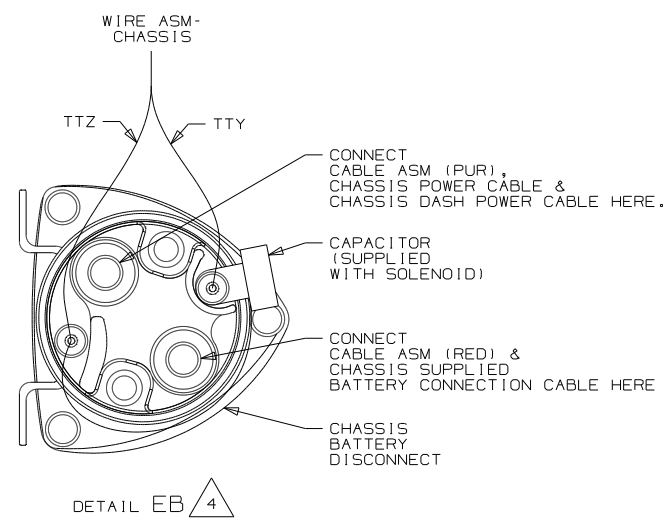

- 4 SEE BATTERY INSTL FOR ADDITIONAL INFORMATION.
- 3 SEE WIRING INSTL-FRONT END FOR ADDITIONAL INFORMATION.
2. SECURE CONDUIT 41953-09, -10, -11, -13, AND -14 OVER ALL WIRES IN CONTACT WITH SHARP EDGES.
1. LEGEND: — WINNEBAGO: - - - - - CABLE: - - - - - CHASSIS SUPPLIED WIRING.
- NOTES:

(ILL)	FRTL (FRED) 27K-300HP 22.5TIRE	
(265)	CODES/STANDARDS-CSA/CMVSS	
(1B1)	CODES/STANDARDS USA	
(1B1)	(265)	(ILL)
FIRST USED		
10 J35P		
DO NOT SCALE DRAWING		
TITLE:		
WIRING INSTL-CHASSIS		
SHEET 5	PART NO	REV
	171905	
1 9/24/2009		

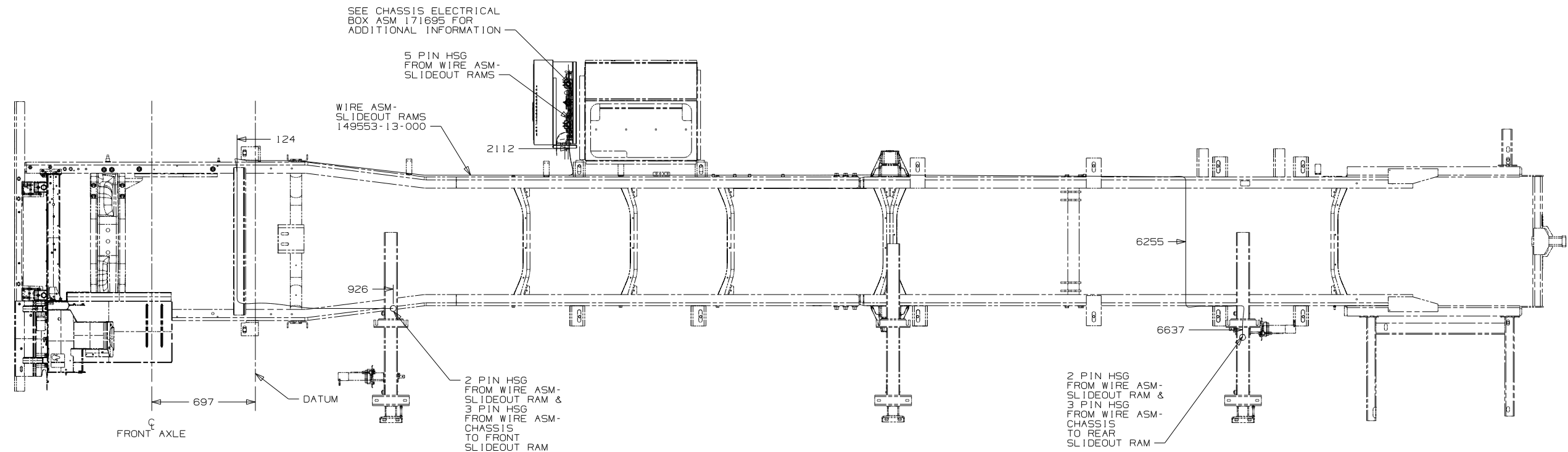

3. WIRE ASM-SLIDEOUT IS ROUTED AND CLAMPED WITH WIRE ASM-CHASSIS.
2. SECURE CONDUIT 41953, TAB AS REQUIRED, OVER ALL WIRES IN CONTACT WITH SHARP EDGES.
1. LEGEND: — WINNEBAGO: - - - - - CABLE: - - - - - CHASSIS SUPPLIED WIRING.

NOTES:

- (1LL) FRTL (FRED) 27K-300HP 22.5 TIRE
- (1PV) WORKHORSE 24,000#-22.5 TIRE
- (1PS) WORKHORSE 22,000#-22.5 TIRE
- (16Z) FORD 24,000#-22.5 ALUM WHEEL
- (16L) FORD 22,000#-22.5 AL WHL
- (265) CODES/STANDARDS-CSA/CMVSS
- (1B1) CODES/STANDARDS USA

(1B1) (265)

FOR ELECTRICAL TORQUE SPECIFICATIONS SEE DWG NO. 128783-01-000

(X-X) FOR ELECTRICAL CALLOUTS SEE DWG NO. 121339-01-000

FIRST USED	10 J35P
TITLE	DO NOT SCALE DRAWING
TITLE	WIRING INSTL-CHASSIS
SHEET 6	PART NO 171905 REV