

- 6 VENT PIPE MUST PROJECT 51 MIN AND 64 MAX ABOVE ROOF FOR PROPER FIT AND FUNCTION.
- SEAL AROUND SHOWER WITH SILICONE.
 - SLOPE OF TRAP ARM MUST BE 6 PER 305 mm.
 - SLOPE OF HORIZONTAL PIPING TO BE MIN 3 PER 305 mm.
 - ALL EXTERIOR OPENINGS AROUND PIPE TO BE SEALED WITH 131264-03-000.
 - ALL PIPE AND FITTINGS TO BE ASSEMBLED WITH SOLVENT 4020-01-000 (US), 4020-02-000 (CAN).

NOTES:

FOR DRAINAGE CALLOUTS SEE DWG NO 116229-01-000

WINNEBAGO		COPYRIGHT 2008 WINNEBAGO INDUSTRIES, INC.	
DFT	ORIG. DATE	ALL DIMENSIONS ARE IN MILLIMETERS	
CHKR		FIRST USED	
P.E.		09 728B	
M.E.		UNSPECIFIED TOLERANCES ARE:	
DSNR		WHOLE DIM (X) : 3	
		ONE-PLACE (X.X) : 1.5	
		TWO-PLACE (X.XX) : 0.50	
		ANGLE : 1°	
THIRD ANGLE PROJECTION		MATERIAL:	
DO NOT SCALE DRAWING			
TITLE: DRAINAGE SYSTEM			
SHEET 1 OF 4	PART NO	165320	REV

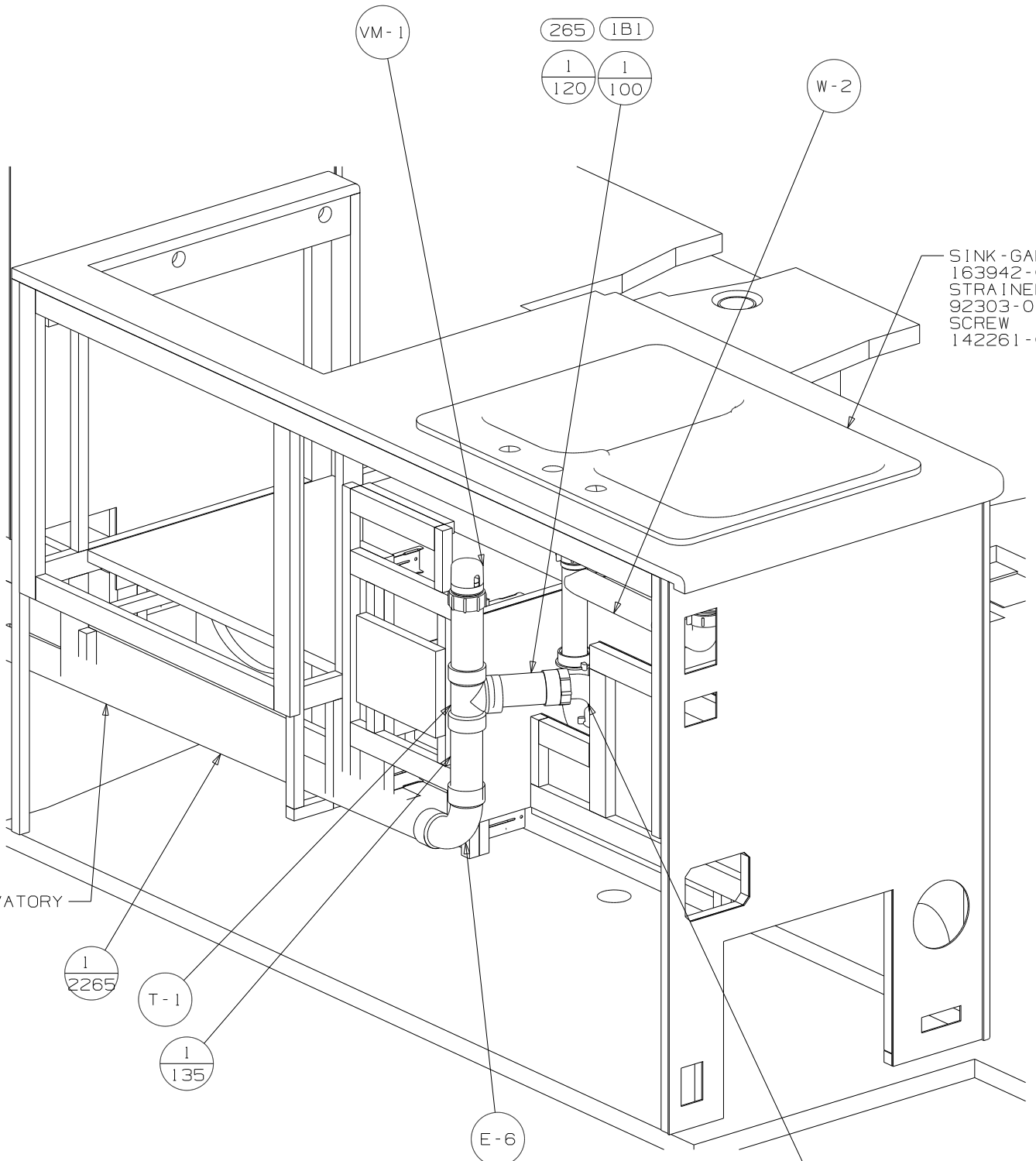

VIEW A

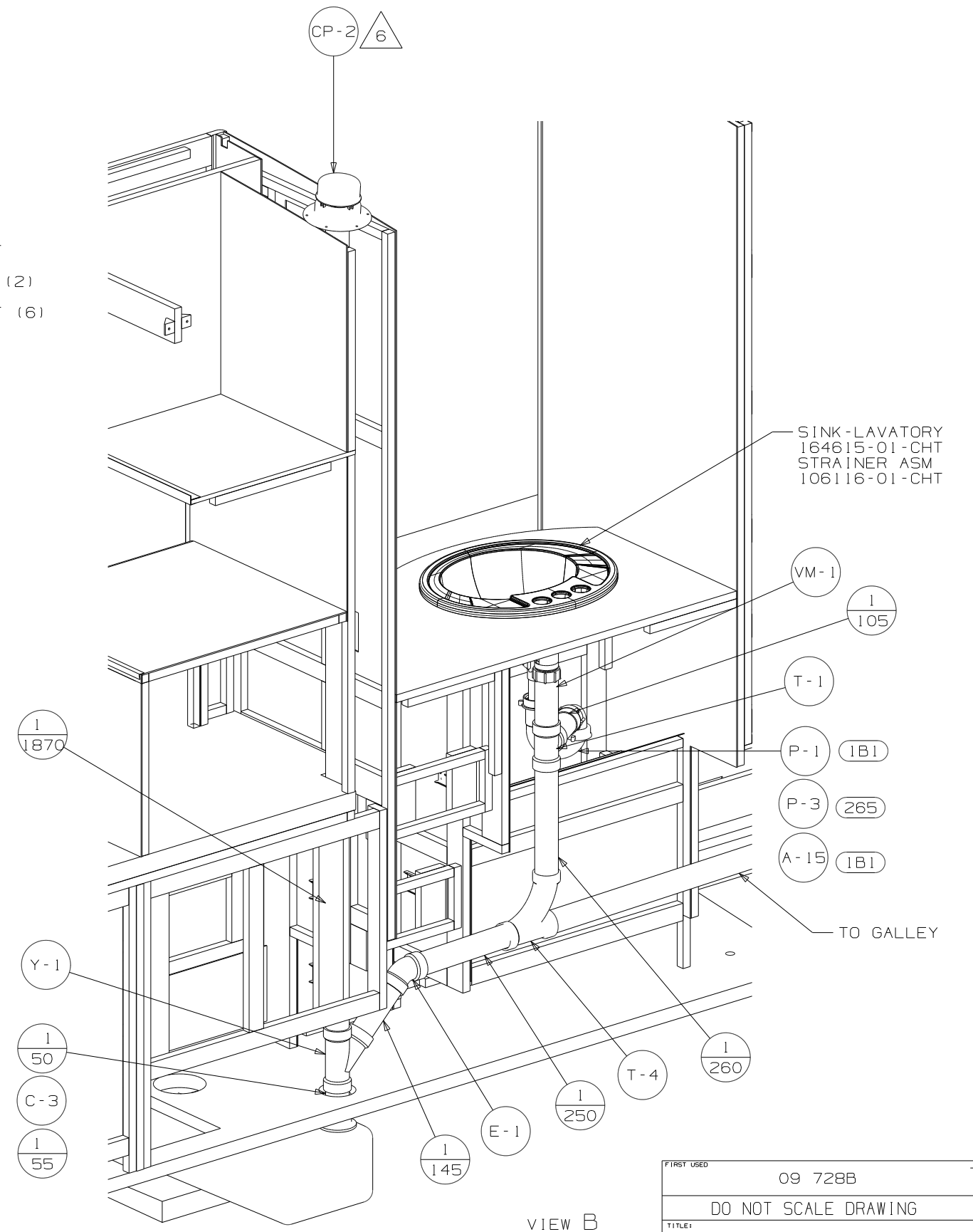

VIEW B

FIRST USED	09 728B		
TITLE:	DO NOT SCALE DRAWING		
	DRAINAGE SYSTEM		
SHEET 2	PART NO	165320	REV
			1 1/30/2008

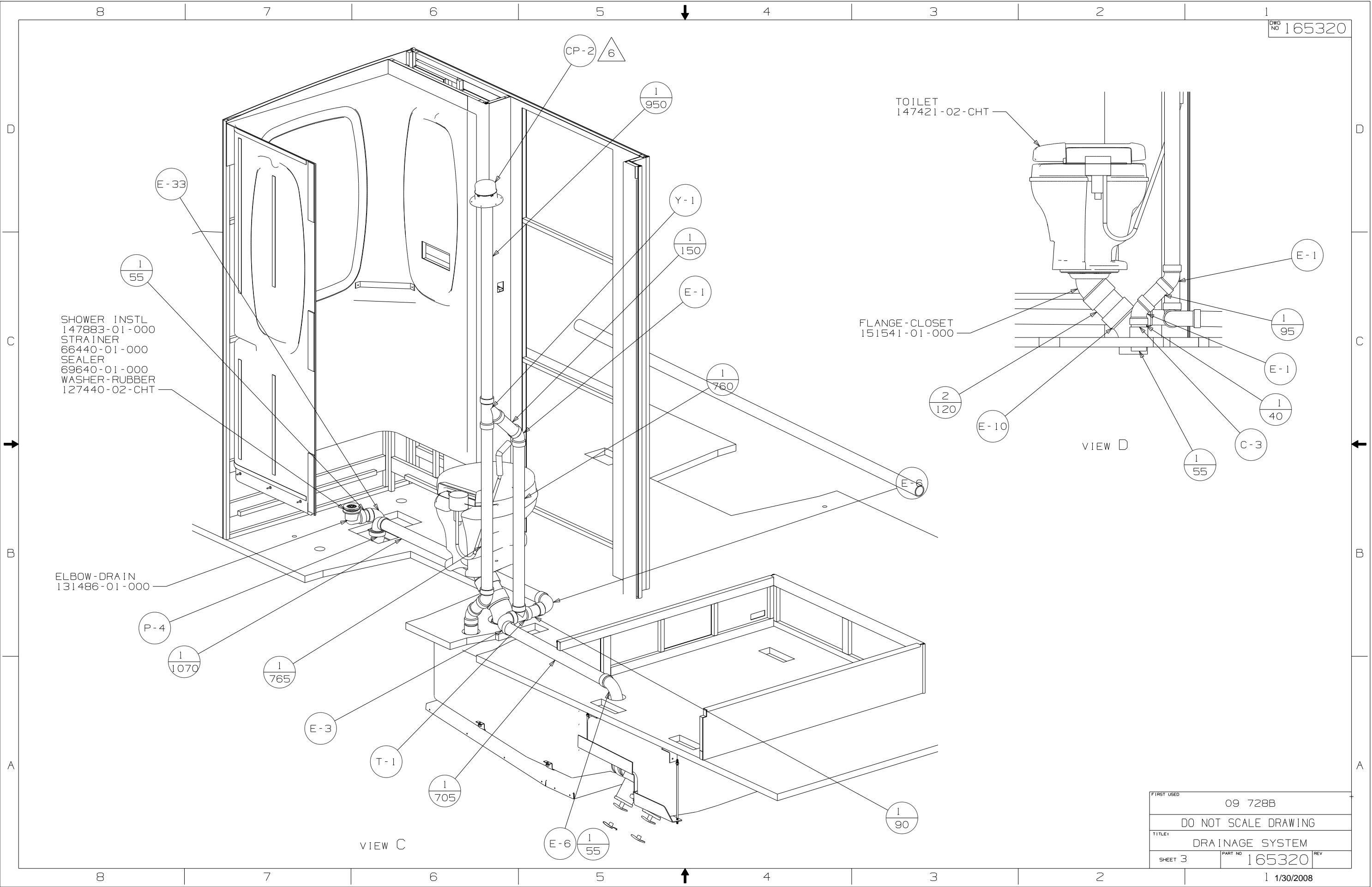

SHOWER INSTL
 147883-01-000
 STRAINER
 66440-01-000
 SEALER
 69640-01-000
 WASHER-RUBBER
 127440-02-CHT

TOILET
 147421-02-CHT

FLANGE-CLOSET
 151541-01-000

ELBOW-DRAIN
 131486-01-000

VIEW D

VIEW C

FIRST USED	09 728B	
TITLE:	DO NOT SCALE DRAWING	
	DRAINAGE SYSTEM	
SHEET 3	PART NO	REV
	165320	

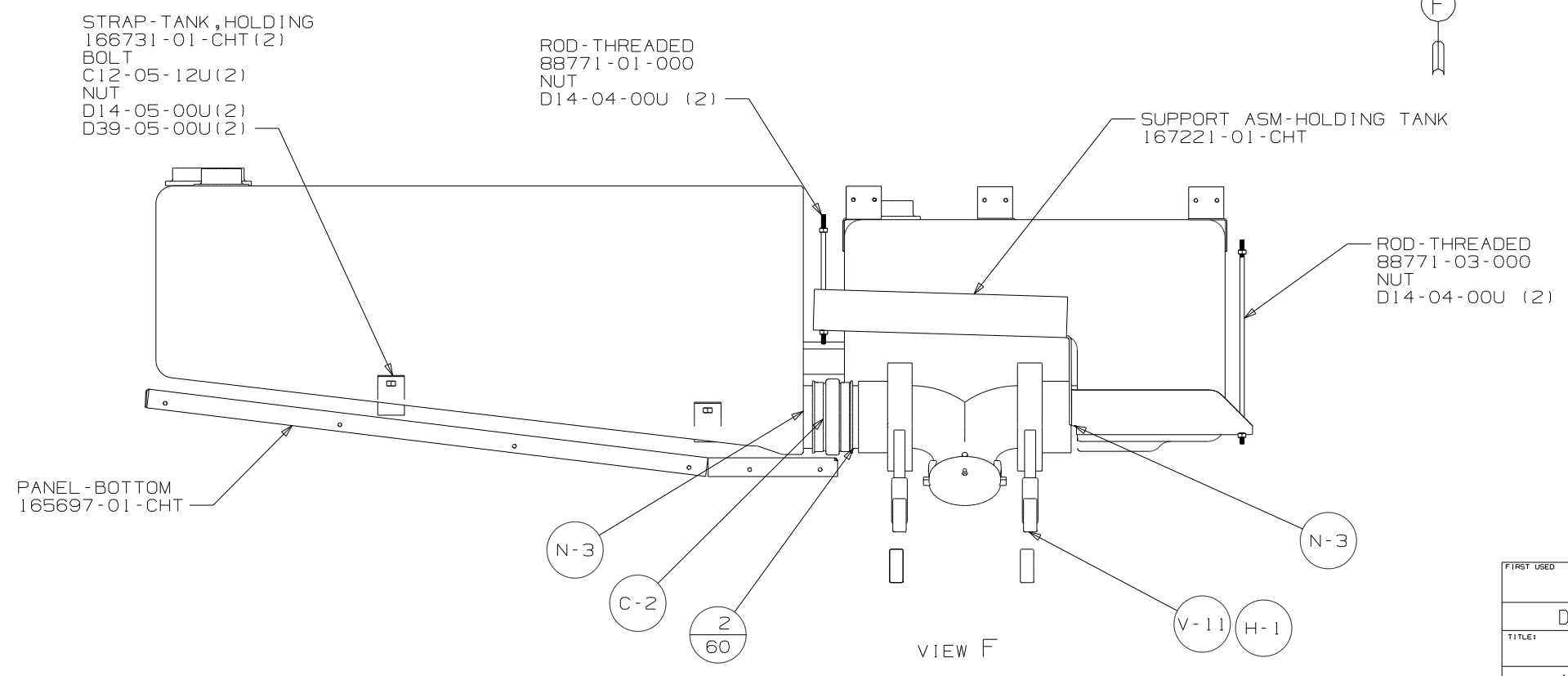
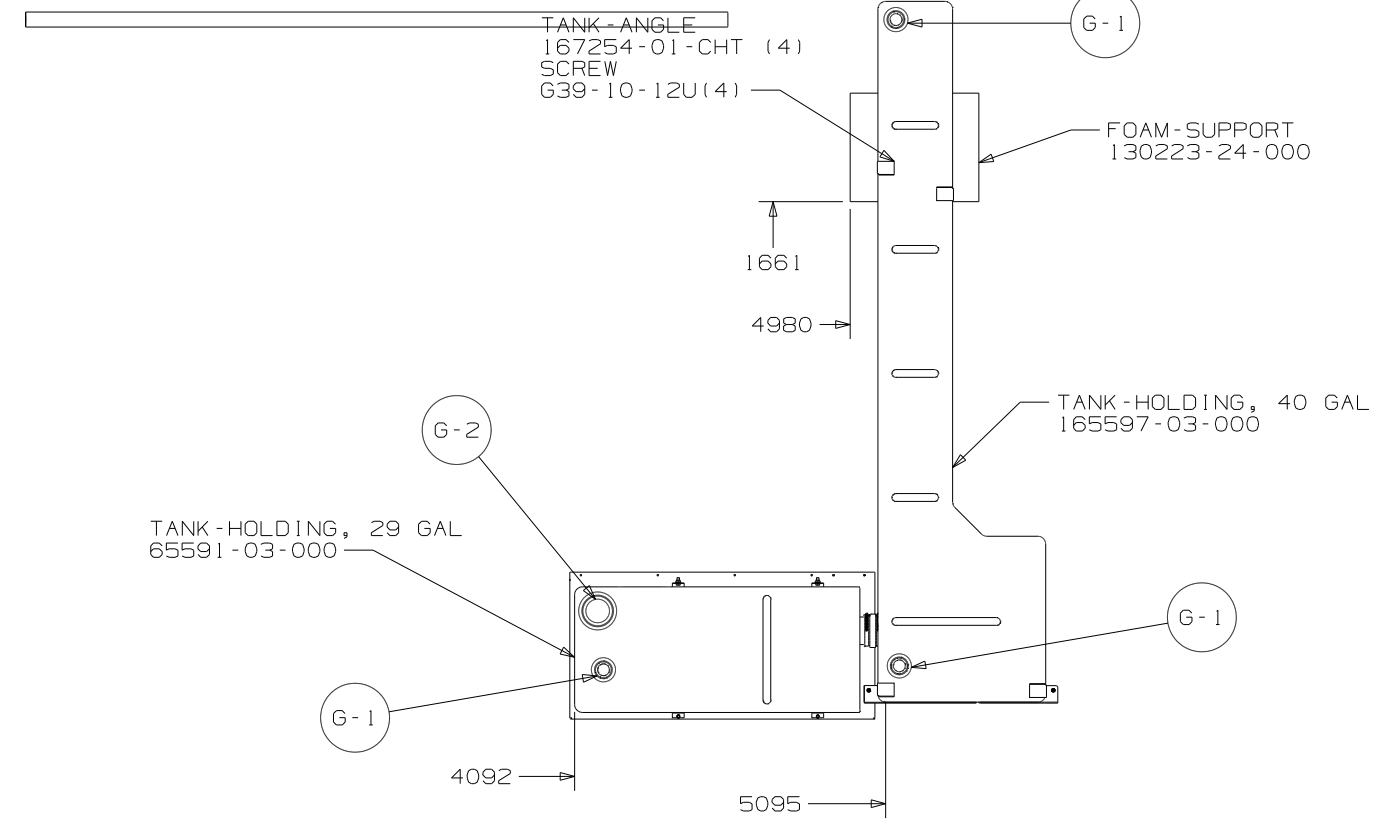
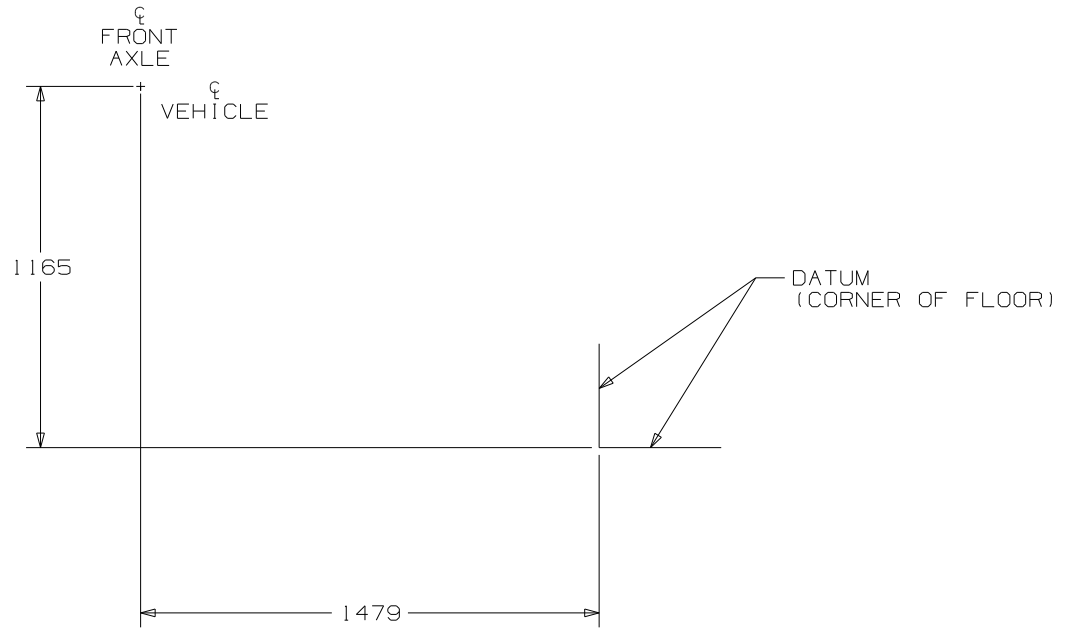

FIRST USED	09 728B	
TITLE	DO NOT SCALE DRAWING	
	DRAINAGE SYSTEM	
SHEET 4	PART NO 165320	REV
	1 1/30/2008	

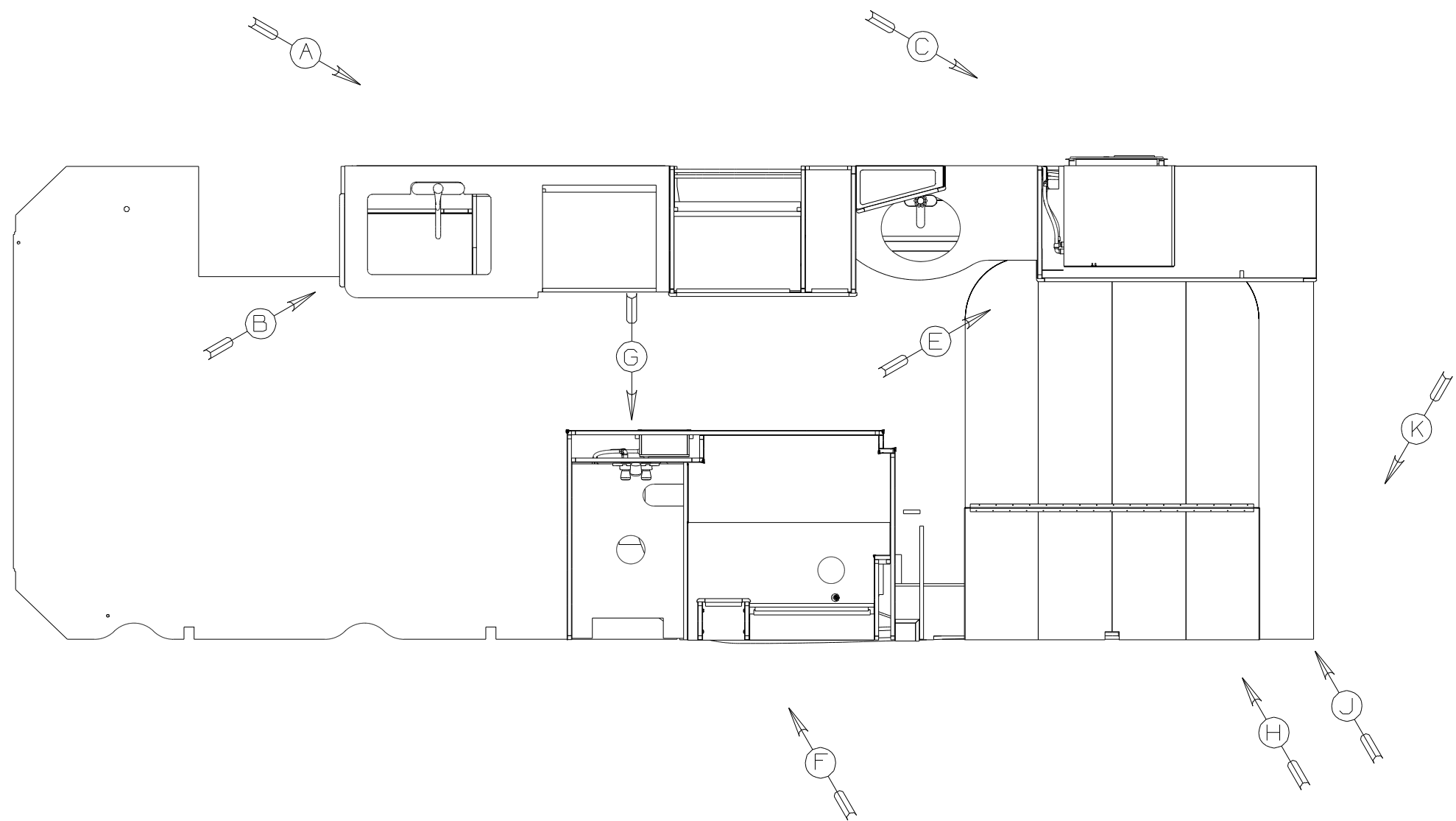

- (53F) WATER HEATER-ELEC. IGNITION
- (53B) WTR HTR-6 GAL ELECTRIC/LP GAS
- (29B) WATER PURIFIER
- (501) WATER PURIFIER-WITHOUT
- (53E) WATER SYS WINTERIZATION PKG
- (64R) EXTERIOR WASH STATION
- (1J4) EXT WASH STATION-WITHOUT
- (1H6) AIR SPRINGS-WITHOUT

- 7 ADD PIPE WRAP (LADDER SCRAP 110157-02-000) INSULATION.
 - 6 ADD TEFLON TAPE 10405-03-000.
 - 5 ADD TEFLON TAPE 10405-02-000.
 - 4 ADD TEFLON TAPE 10405-01-000.
3. ALL TUBING TO BE SECURED AT 1200 INTERVALS MAXIMUM WITH CLAMP 10495-01-000 AND SCREW G67-10-12B OR EQUIVALENT.
 2. TUBING TO BE INSTALLED WITH SUFFICIENT SLOPE TO PROVIDE DRAINAGE TO NEAREST VALVE.
 1. PLASTIC FITTINGS TO BE SEALED WITH SEALANT 84456-01-000.

NOTES:

(X-X)
FOR
WATER
CALLOUTS
SEE DWG NO
116230-01-000

WINNEBAGO		COPYRIGHT 2008 WINNEBAGO INDUSTRIES, INC.	
DFTR	ORIG. DATE	ALL DIMENSIONS ARE IN MILLIMETERS	
CHKR		FIRST USED	
P.E.		09 728B	
M.E.		UNSPECIFIED TOLERANCES ARE:	
DSNR		MATERIAL:	
		WHOLE DIM (X)	: 3
		ONE-PLACE (X.X)	: 1.5
		TWO-PLACE (X.XX)	: 0.50
		ANGLE	: 1°
THIRD ANGLE PROJECTION		DO NOT SCALE DRAWING	
TITLE: WATER SYSTEM INSTL			
SHEET 1 OF 7	PART NO	165328	REV
REF:	1 1/30/2008		

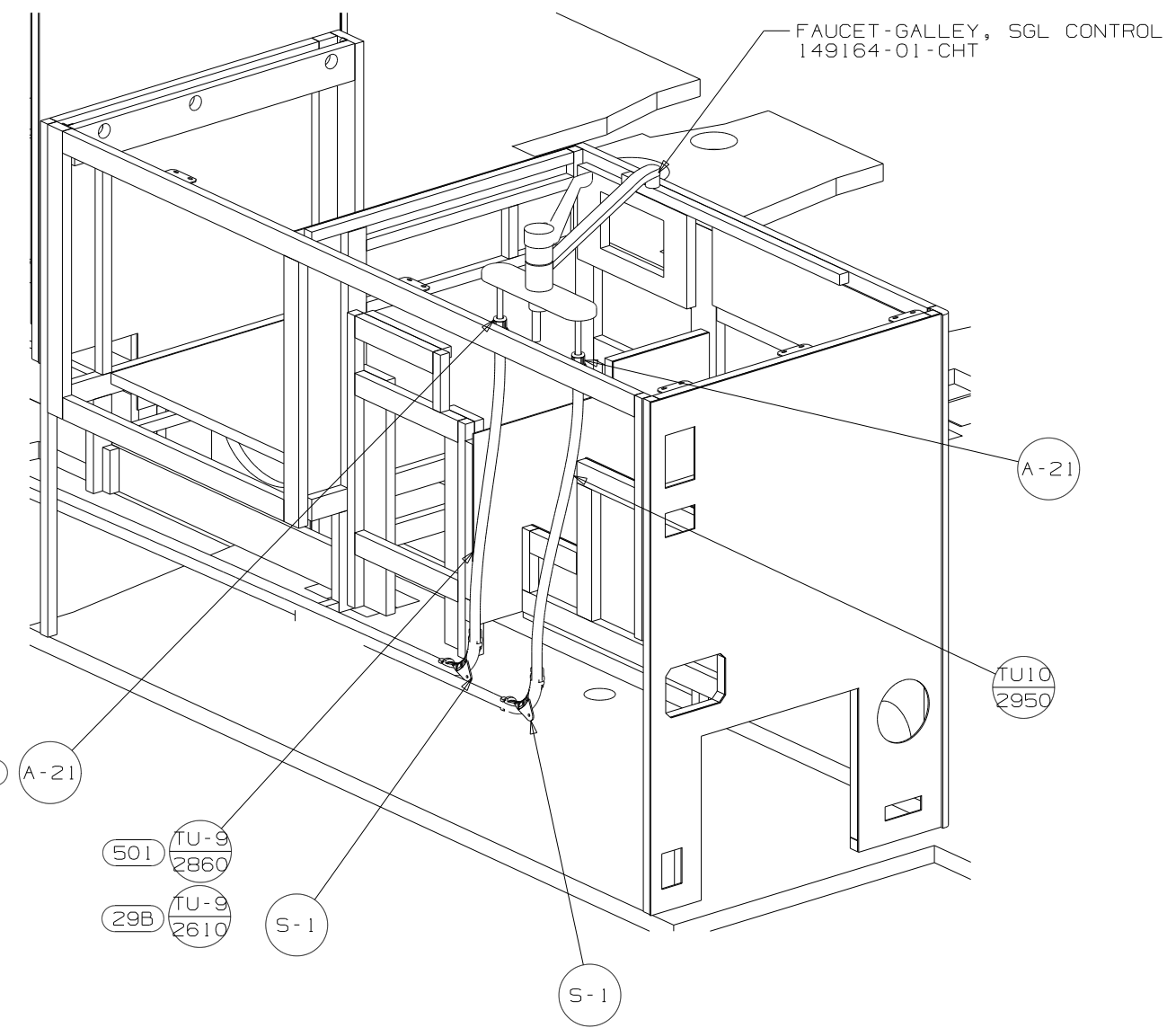

VIEW A

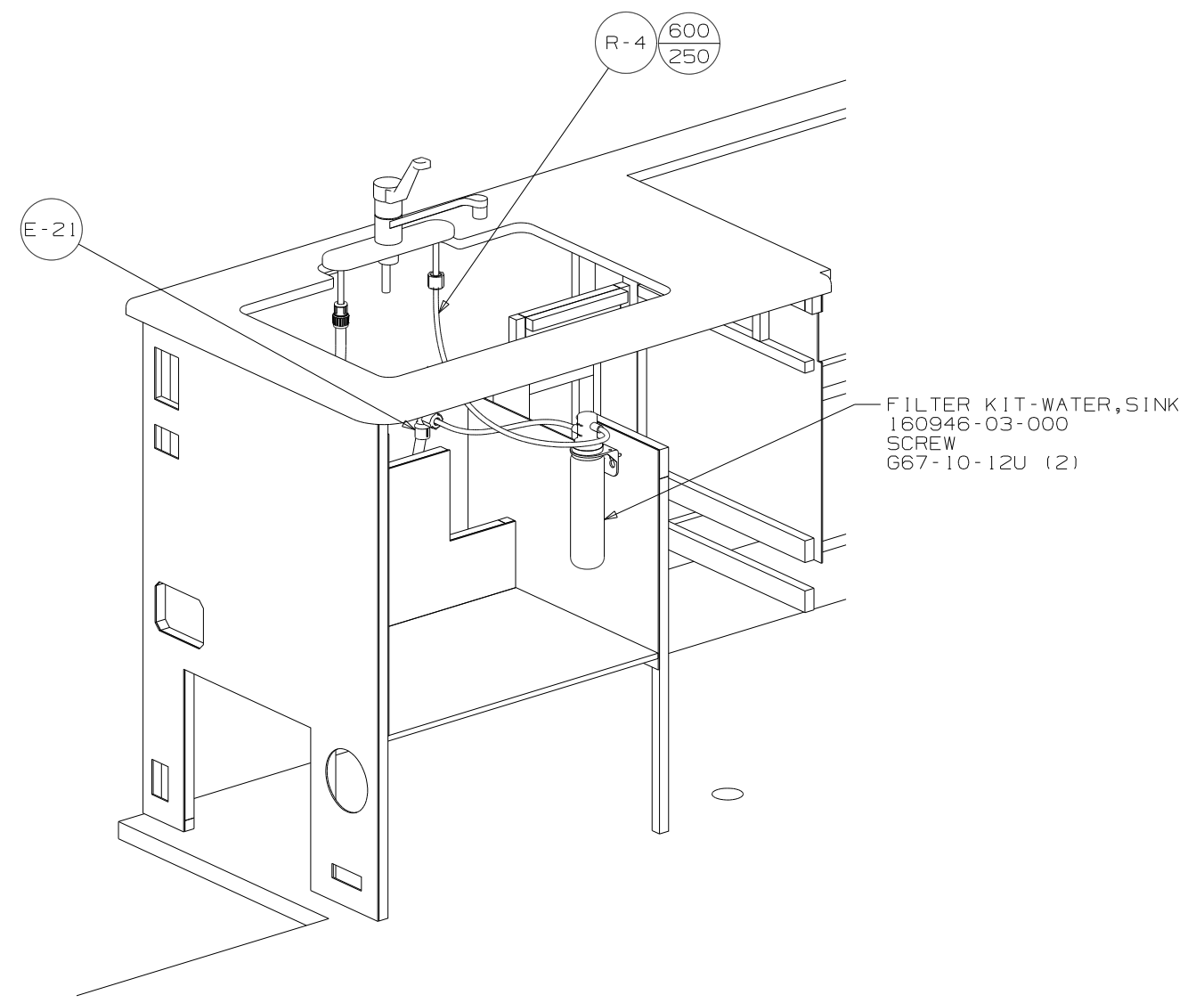

VIEW B

29B

FIRST USED	09 728B
DO NOT SCALE DRAWING	
TITLE:	WATER SYSTEM INSTL
SHEET 2	PART NO 165328 REV

- (53F) WATER HEATER
51391-03-000
- (53B) DOOR
145541-02-000
- 125420-06-CHT
FLANGE
- 152239-01-CHT
EXTR
- 151293-51-004 (2)
- 151293-51-005 (2)
- SCREW
- G39-10-169 (16)
- SEALANT
- 69640-14-000
- 112864-01-000
- CABLE
- 76767-03-000
- SCREW
- G11-06-08B (2)

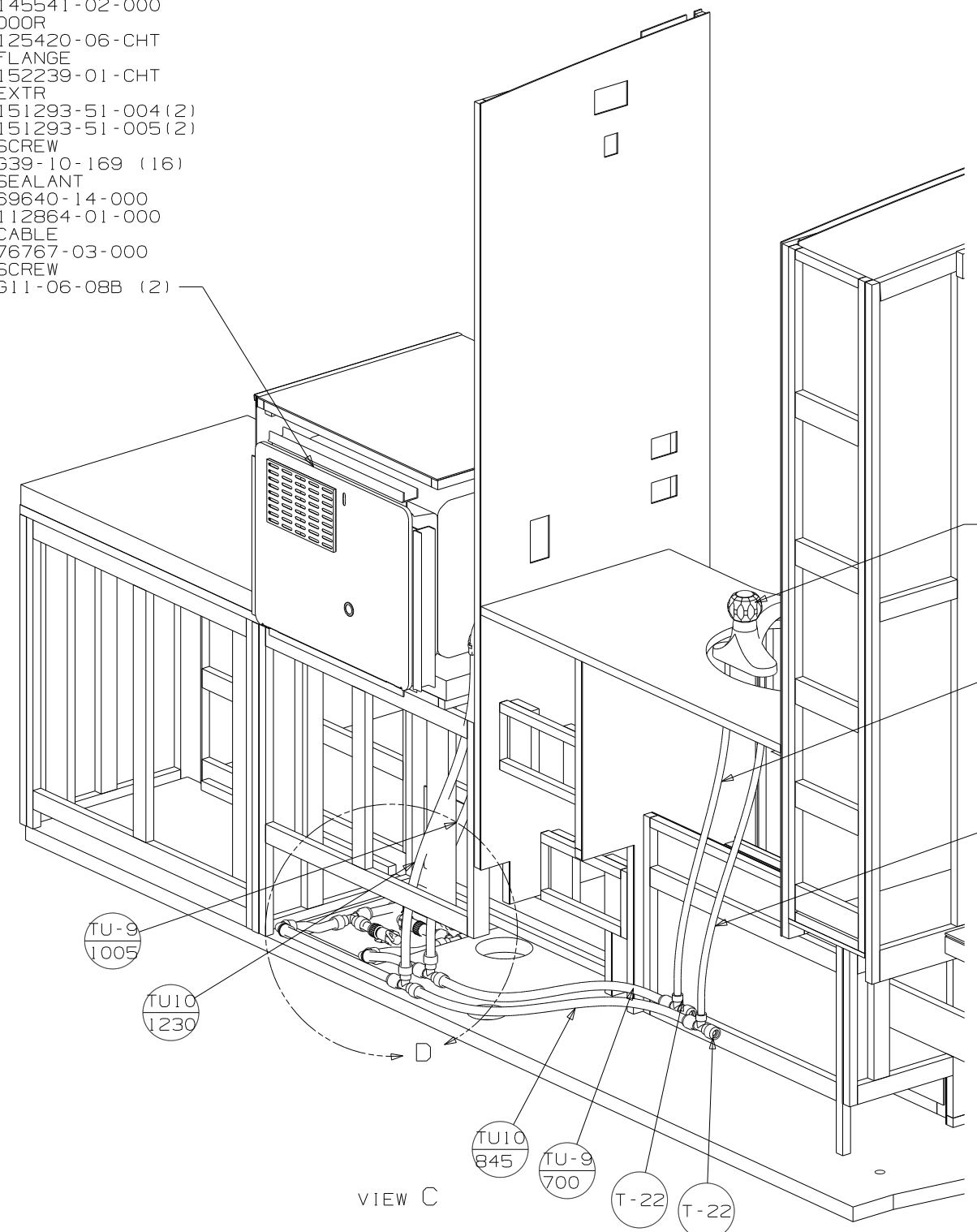

VIEW C

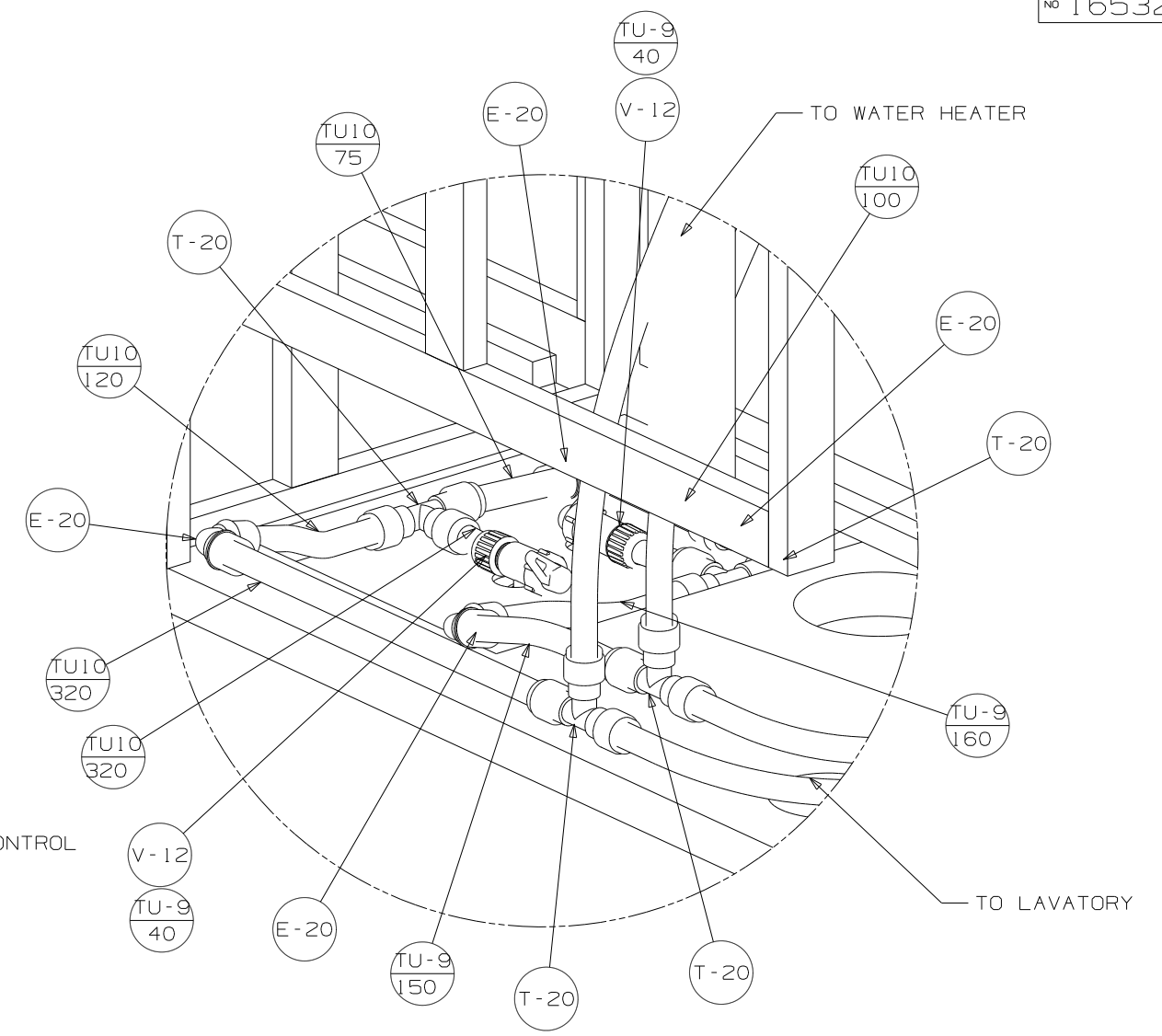

DETAIL D

FIRST USED	09 728B
DO NOT SCALE DRAWING	
TITLE	WATER SYSTEM INSTL
SHEET 3	PART NO 165328 REV

PANEL
78498-01-CHT
SCREW
G11-08-12U (4)
COVER
78500-01-CHT
NUT-SPEED,U
40921-05-000 (4)

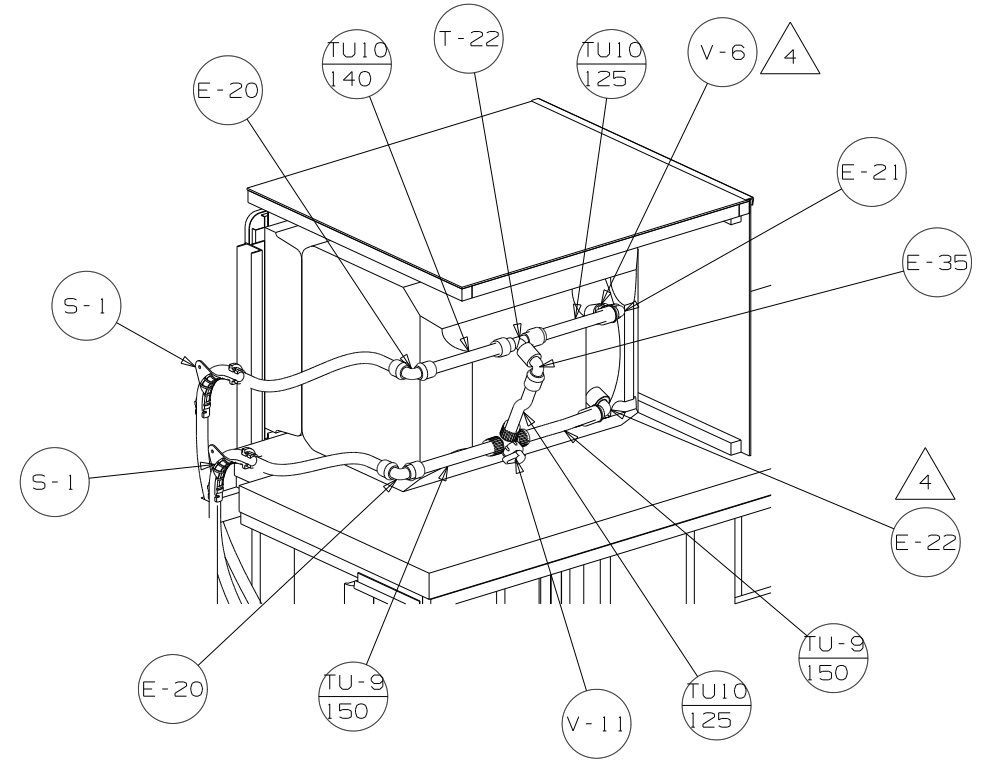

VIEW E

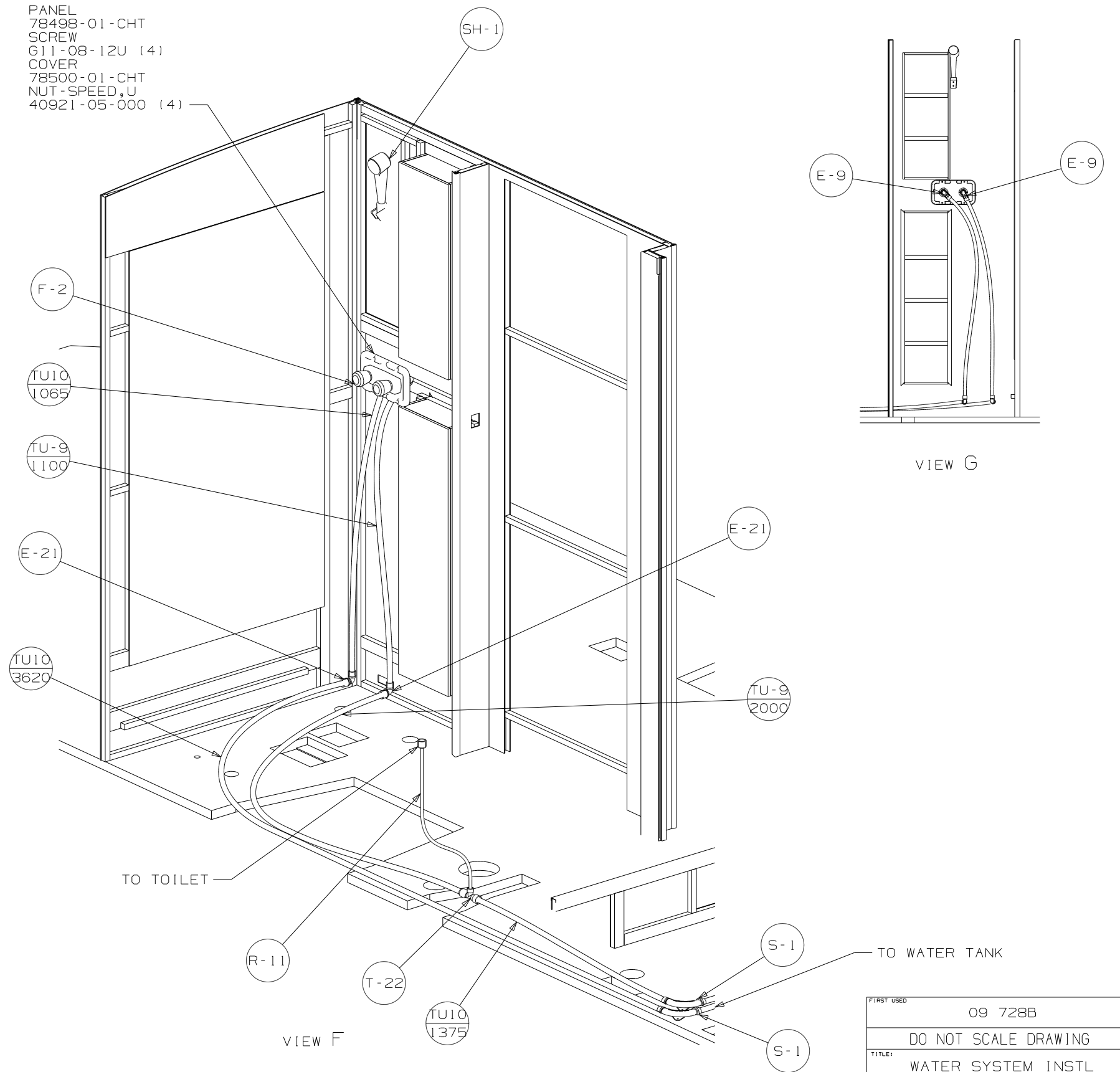

VIEW F

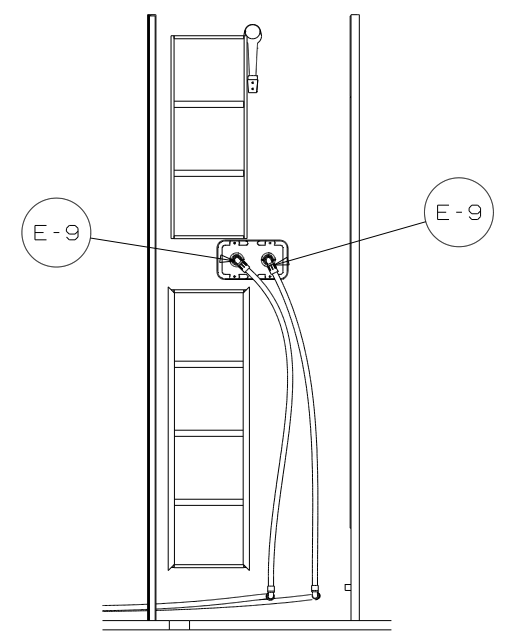

VIEW G

FIRST USED	09 728B
DO NOT SCALE DRAWING	
TITLE:	WATER SYSTEM INSTL
SHEET 4	PART NO 165328 REV

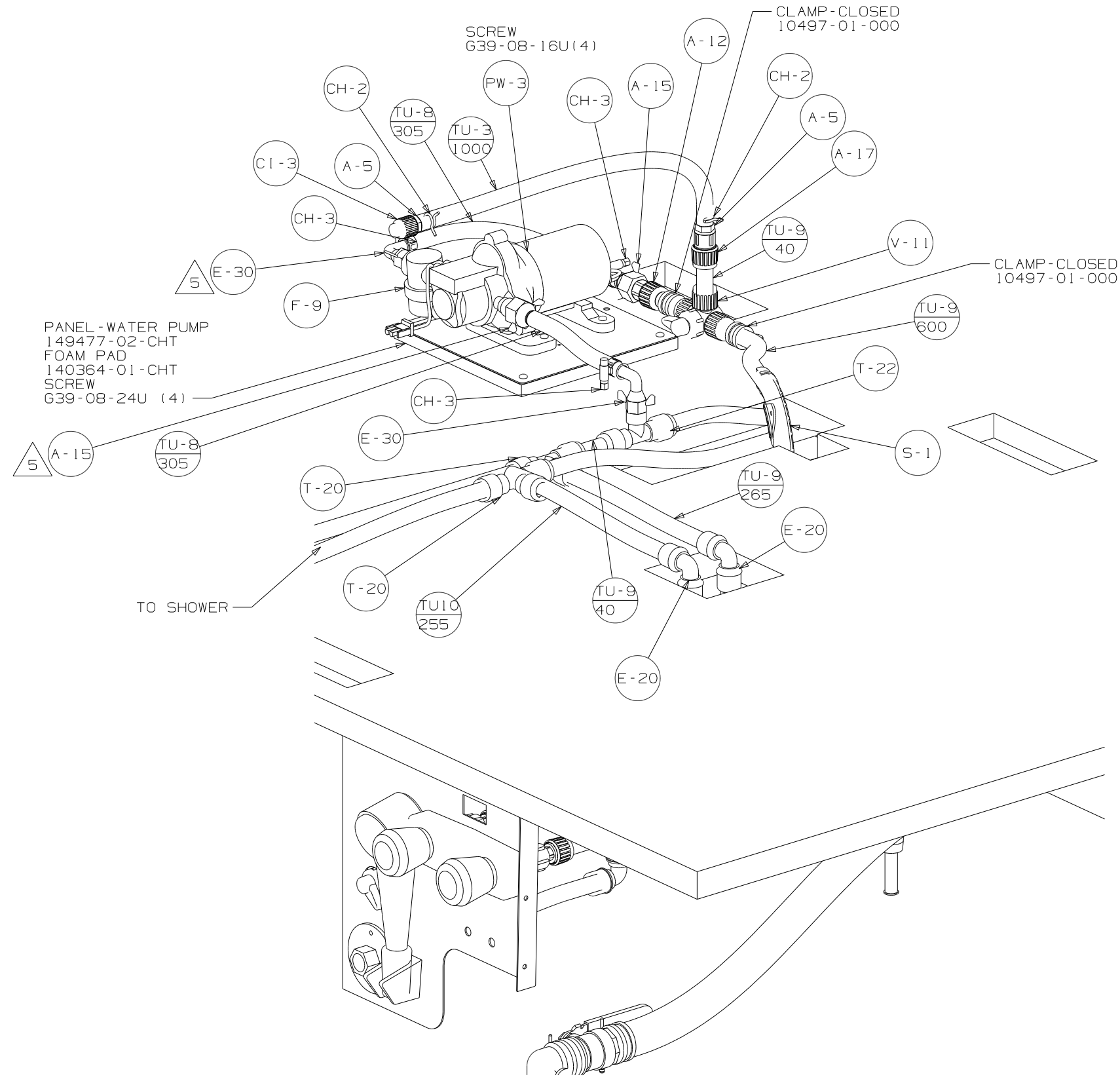

VIEW H

FIRST USED	09 728B	
TITLE	DO NOT SCALE DRAWING	
	WATER SYSTEM INSTL	
SHEET 5	PART NO 165328	REV

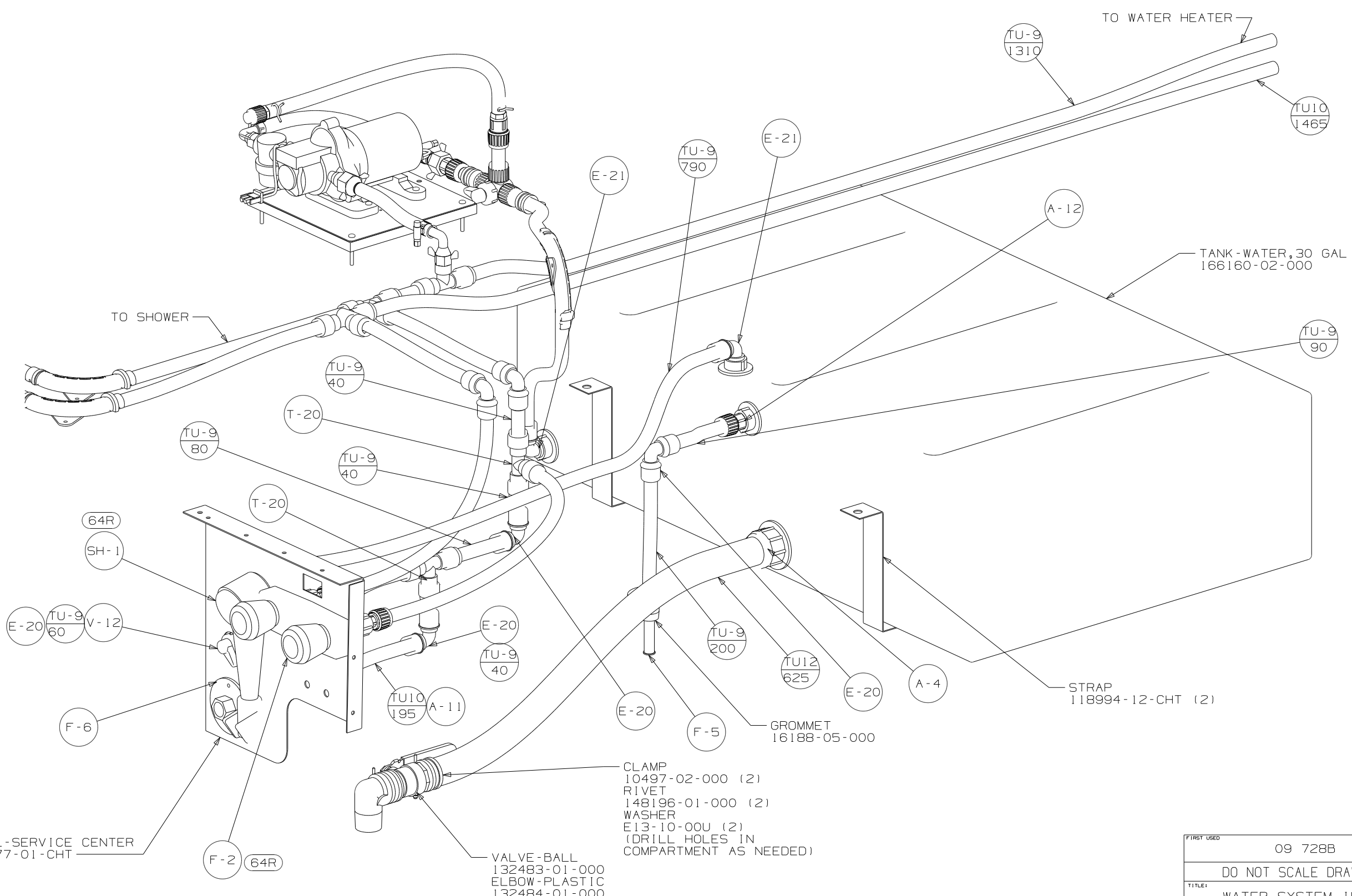

VIEW J

FIRST USED	09 728B
TITLE	DO NOT SCALE DRAWING
SHEET 6	PART NO 165328 REV
	1 1/30/2008

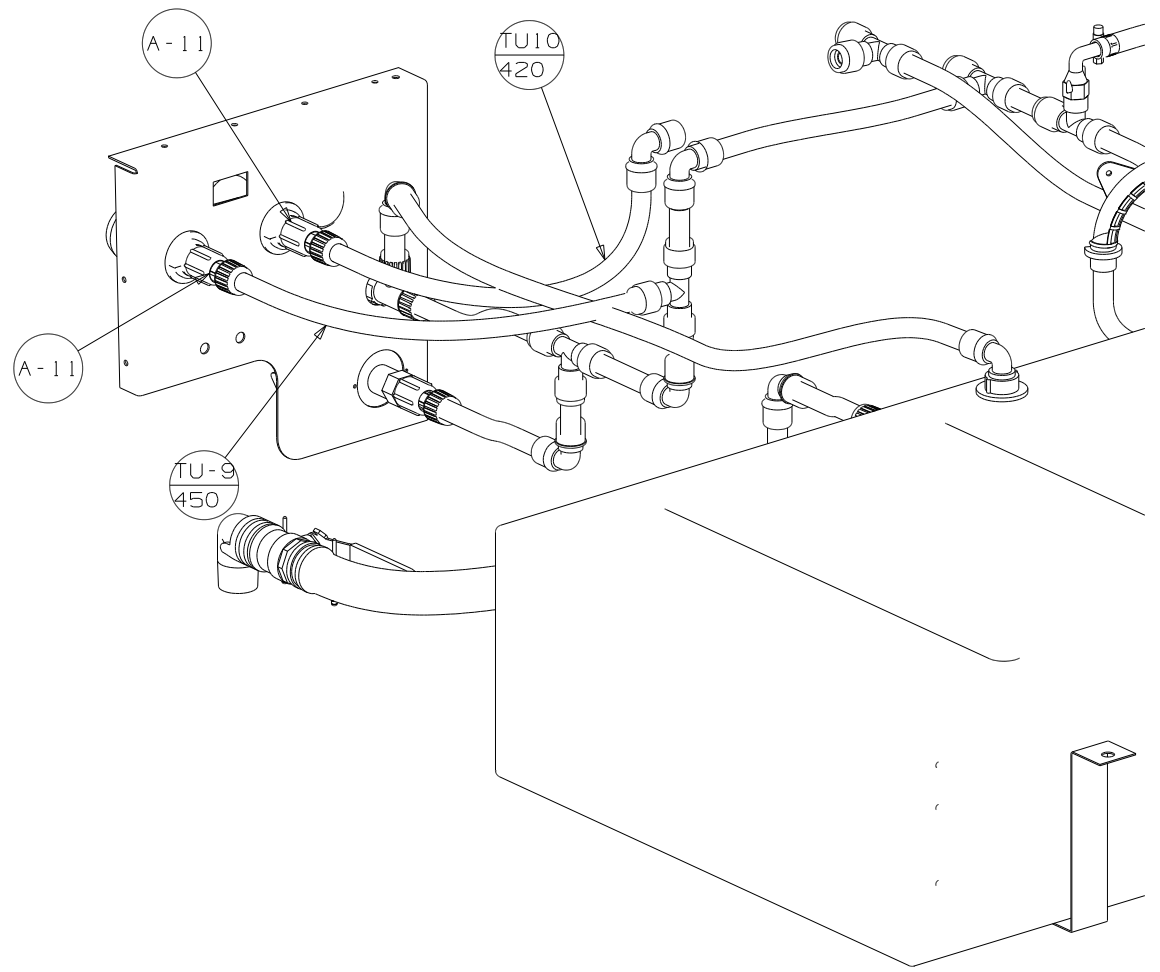

VIEW K
64R

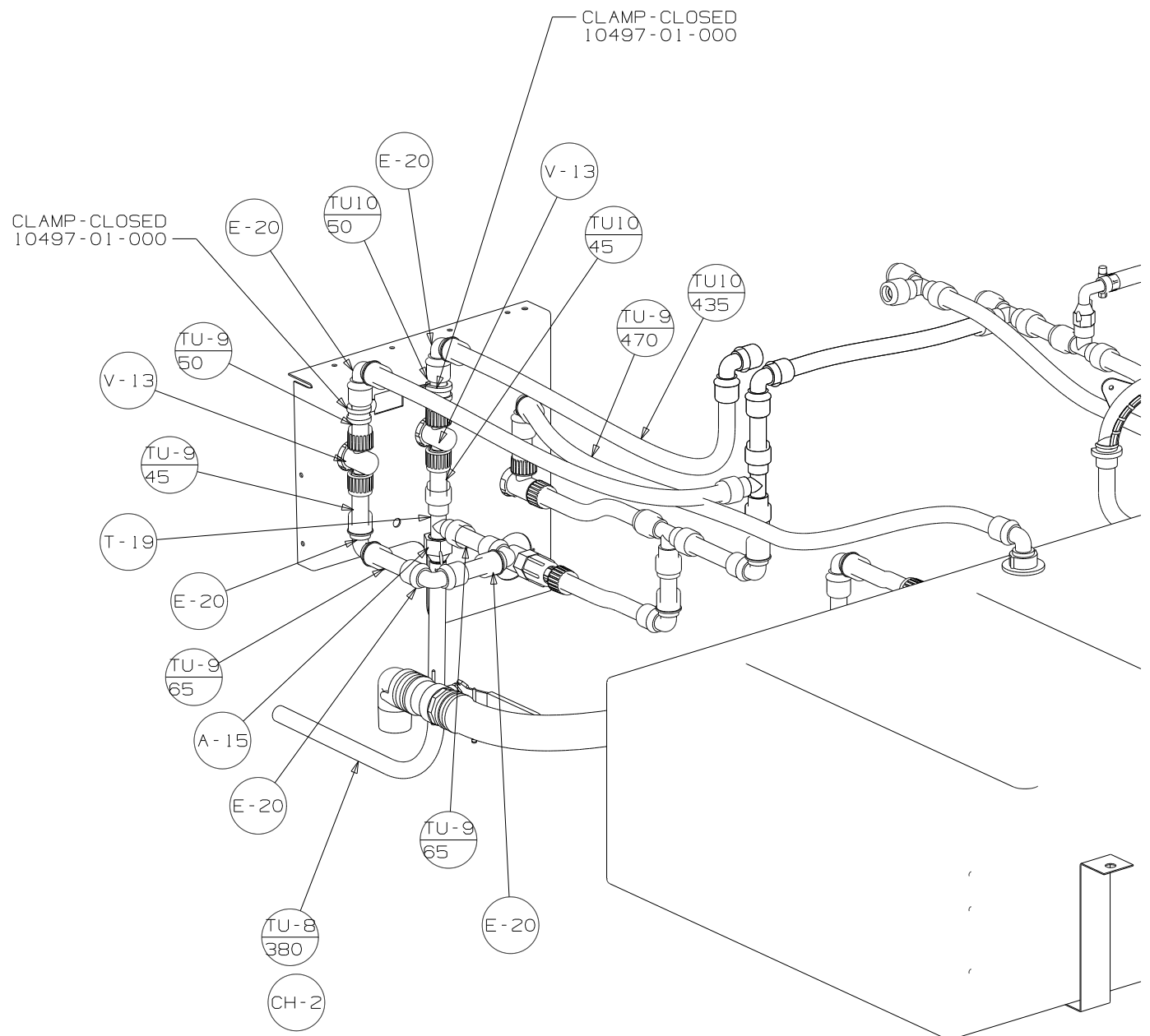

VIEW K
1J4

FIRST USED	09 728B
DO NOT SCALE DRAWING	
TITLE:	WATER SYSTEM INSTL
SHEET 7	PART NO 165328 REV