

- (464) TOILET
- (644) GREAT ALASKAN RENTAL PACKAGE
- (23T) DRAINAGE SYSTEM-HEATED
- (23R) DRAINAGE SYSTEM/HEAT-PREWIRE
- (1B1) CODES/STANDARDS USA
- (265) CODES/STANDARDS-CSA/CMVSS

- NOTES:
7. SECURE VENT TUBES TO FLOOR WITH CLAMP 62401-02-000 (2), SCREW G67-10-12B (2), BRACKET 136878-01-CHT (2).
  6. VENT PIPE MUST PROJECT 51 MIN AND 64 MAX ABOVE ROOF FOR PROPER FIT AND FUNCTION.
  5. SEAL AROUND SHOWER WITH SILICONE.
  4. SEE WIRING INSTL-BODY, 12V FOR ELECTRICAL CONNECTION.
  3. ALL PIPE AND FITTINGS TO BE ASSEMBLED WITH SOLVENT 4020-01-000 (USA), 4020-02-000 (CAN)
  2. SLOPE OF TRAP ARM MUST BE 6 PER 305 mm.
  1. SLOPE OF HORIZONTAL PIPING TO BE MIN 3 PER 305 mm.

FOR DRAINAGE CALLOUTS SEE DWG NO 116229-01-000

<b>WINNEBAGO</b>		COPYRIGHT 2009 WINNEBAGO INDUSTRIES, INC.	
DFT	ORIG. DATE	ALL DIMENSIONS ARE IN MILLIMETERS	
CHKR		FIRST USED	
P.E.		09 229T	
M.E.		UNSPECIFIED TOLERANCES ARE:	
DSNR		MATERIAL:	
		WHOLE DIM (X)	: 3
		ONE-PLACE (X.X)	: 1.5
		TWO-PLACE (X.XX)	: 0.50
		ANGLE	: 1°
THIRD ANGLE PROJECTION		DO NOT SCALE DRAWING	
TITLE:		DRAINAGE SYSTEM INSTL	
SHEET 1 OF 4	PART NO	165656	REV
REF:	1 3/19/2009		

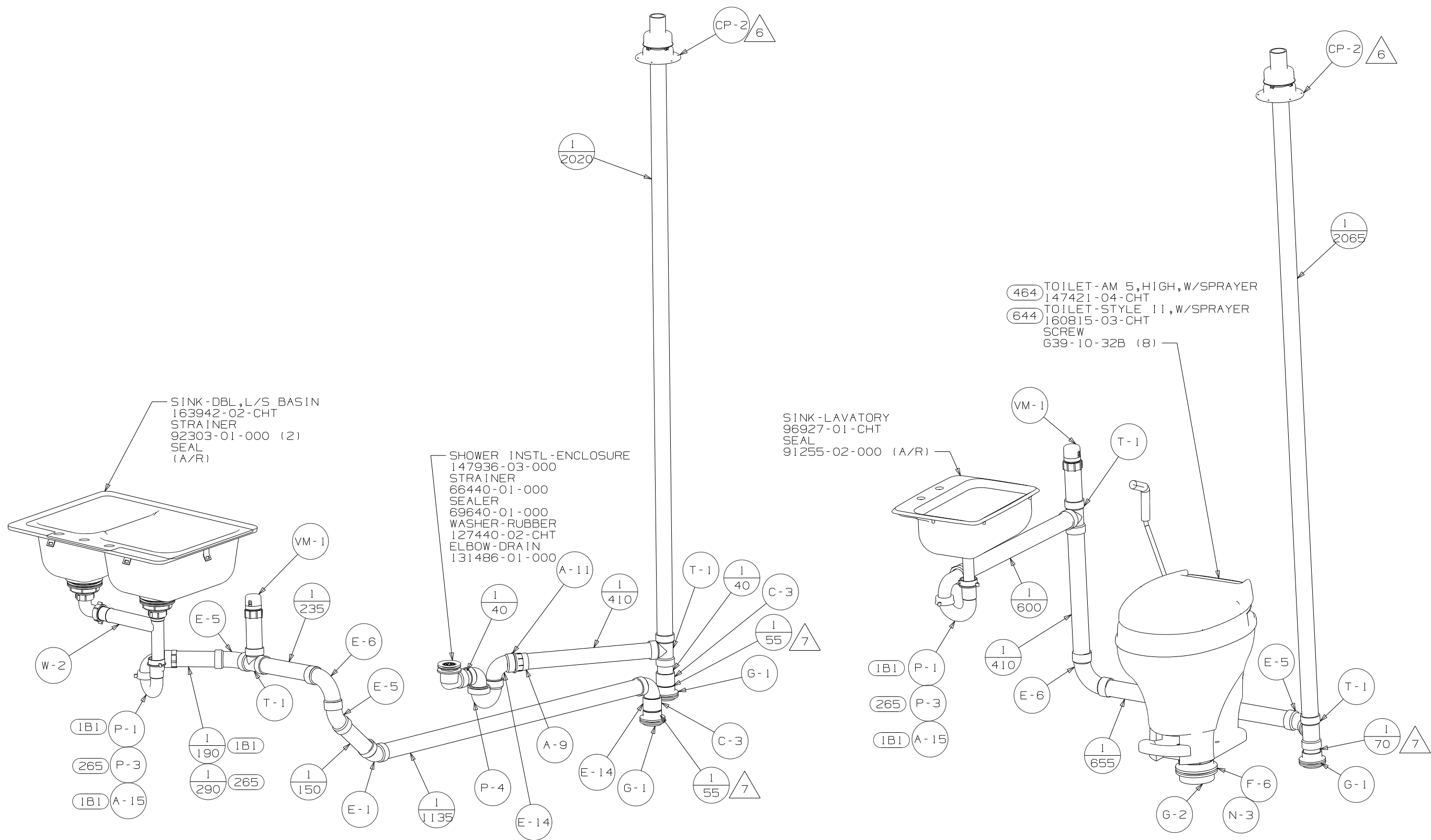

SINK-DBL,L/S BASIN  
163942-02-CHT  
STRAINER  
92303-01-000 (2)  
SEAL  
(A/R)

SHOWER INSTL-ENCLOSURE  
147936-03-000  
STRAINER  
66440-01-000  
SEALER  
69640-01-000  
WASHER-RUBBER  
127440-02-CHT  
ELBOW-DRAIN  
131486-01-000

SINK-LAVATORY  
96927-01-CHT  
SEAL  
91255-02-000 (A/R)

464 TOILET-AM 5,HIGH,W/SPRAYER  
147421-04-CHT  
644 TOILET-STYLE 11,W/SPRAYER  
160815-03-CHT  
SCREW  
G39-10-32B (8)

VIEW A

VIEW C

FIRST USED	09 229T		
TITLE	DO NOT SCALE DRAWING		
	DRAINAGE SYSTEM INSTL		
SHEET 2	PART NO	165656	REV

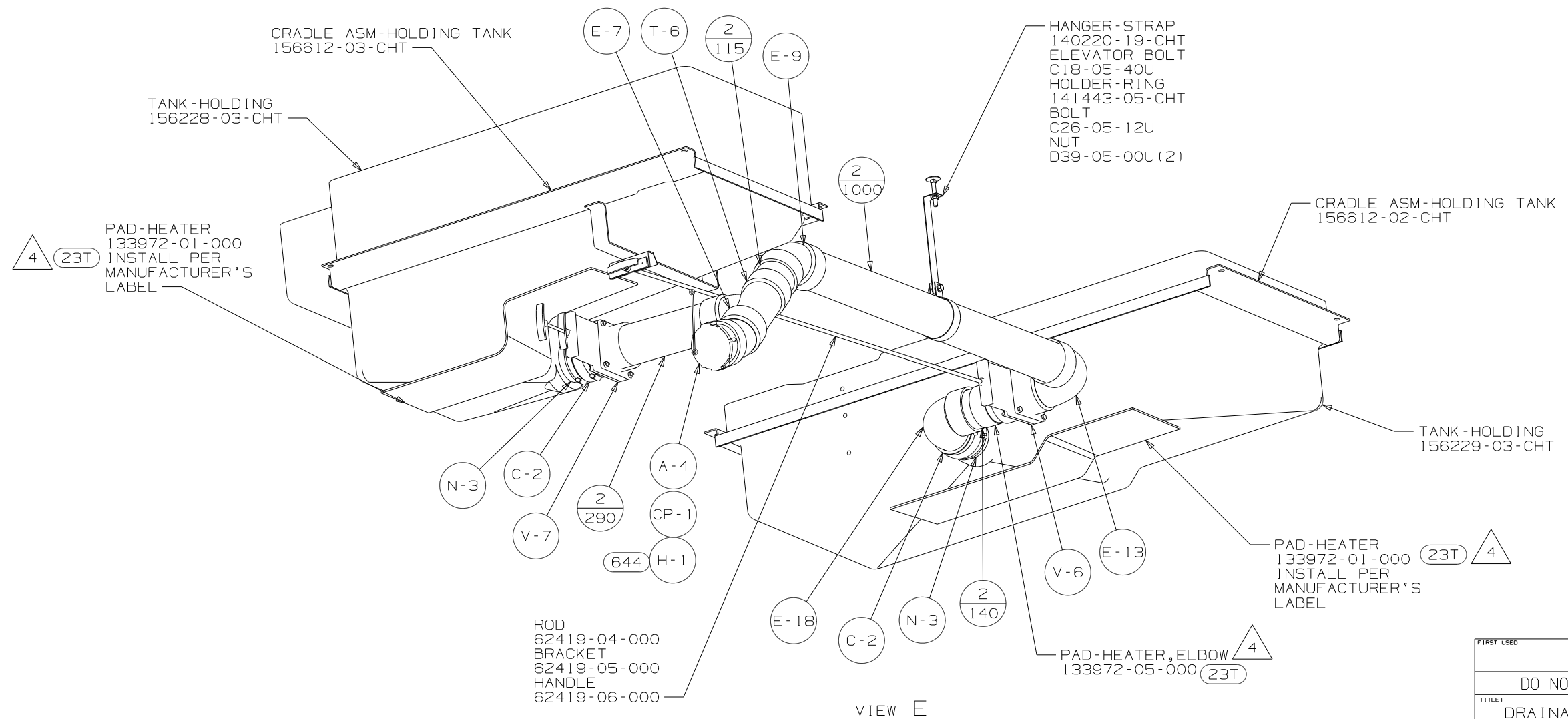
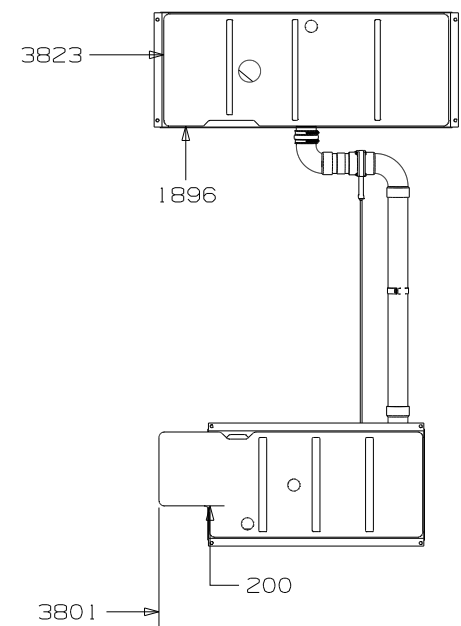
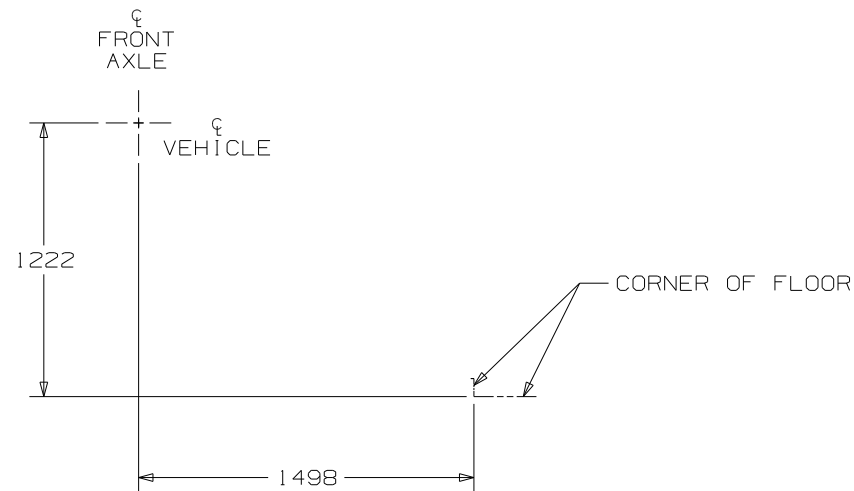

FIRST USED	09 229T
DO NOT SCALE DRAWING	
TITLE	DRAINAGE SYSTEM INSTL
SHEET 3	PART NO 165656 REV

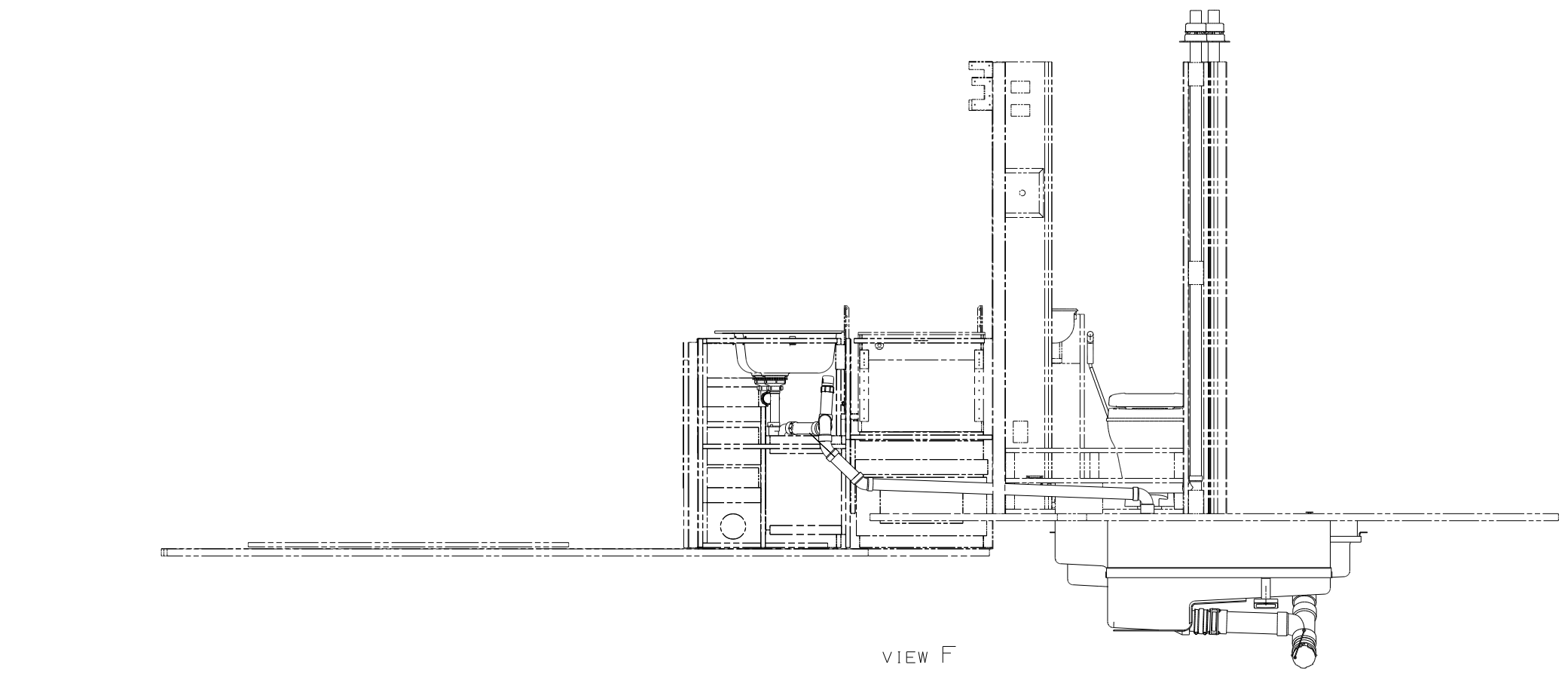

VIEW F

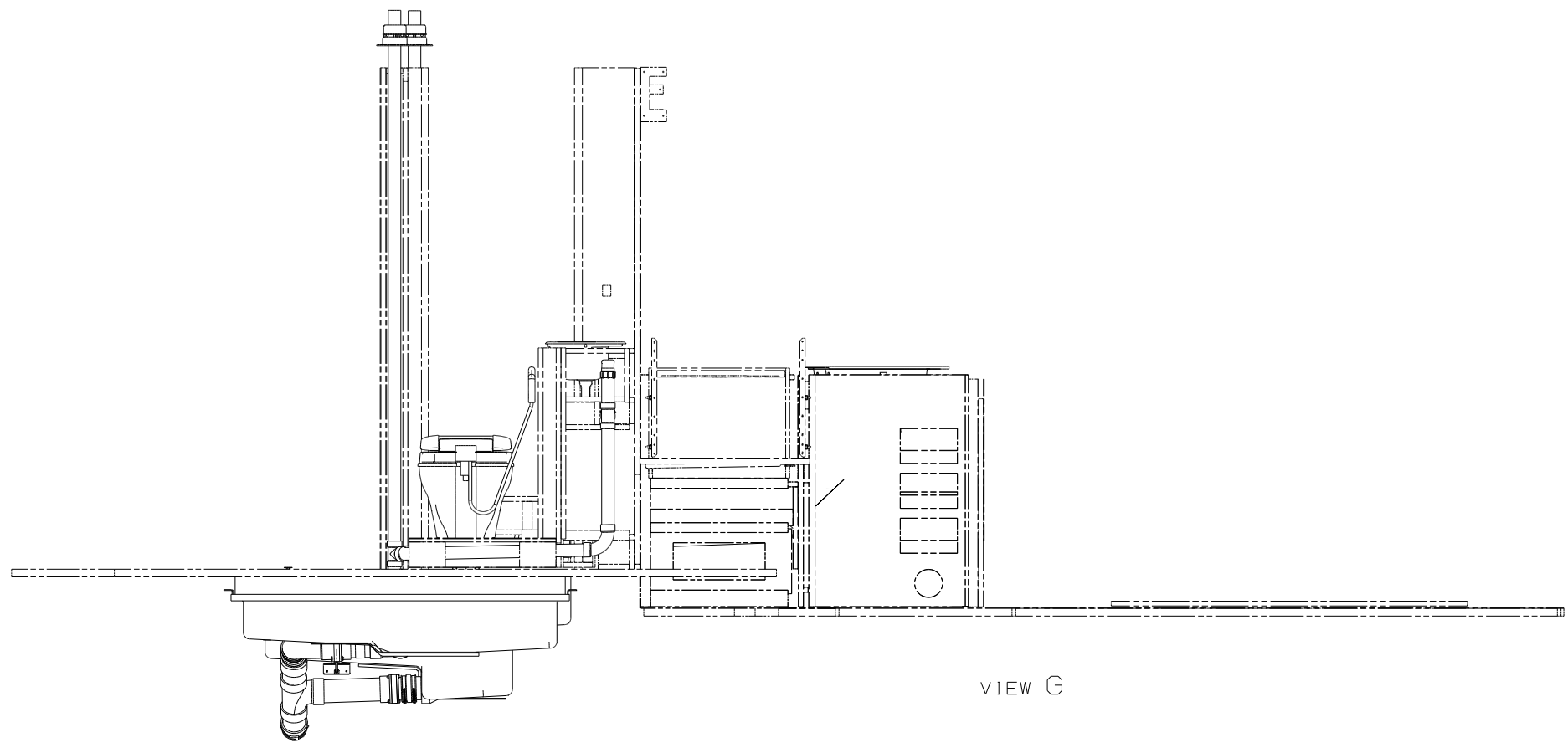

VIEW G

FIRST USED	09 229T		
TITLE	DO NOT SCALE DRAWING		
	DRAINAGE SYSTEM INSTL		
SHEET 4	PART NO	165656	REV

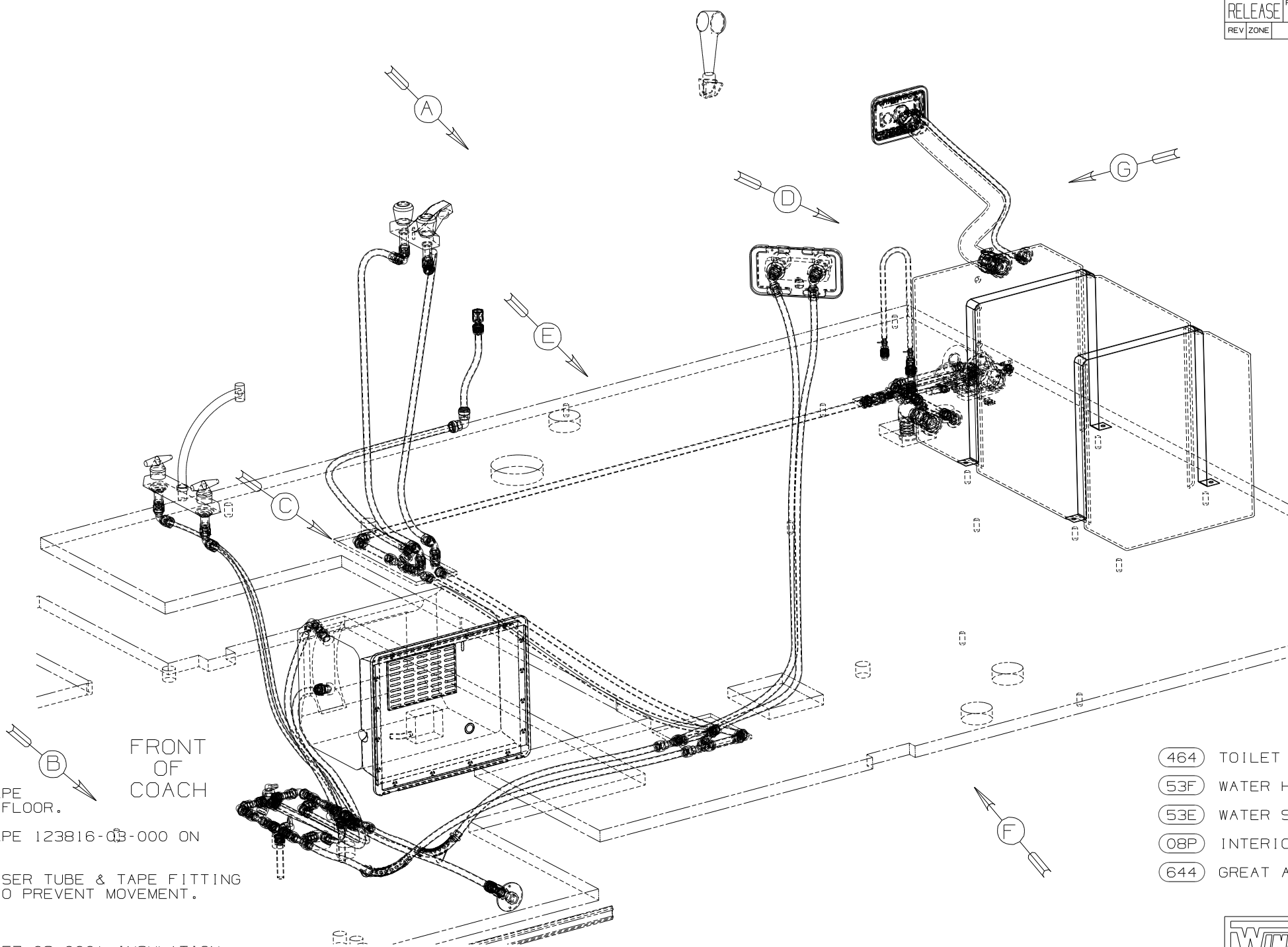

- 11 ATTACH WASHER 087080-13, WITH TAPE 123816-03-000 ON BOTTOM SIDE OF FLOOR.
- 10 ATTACH WASHER 087080-11, WITH TAPE 123816-03-000 ON BOTTOM SIDE OF COMPARTMENT.
- 9 LABEL THE HOT AND COLD SYSTEM RISER TUBE & TAPE FITTING TO THE TUBE BEFORE CABINET SET TO PREVENT MOVEMENT.
- 8 NOT REQUIRED W/ (644).
- 7 ADD PIPE WRAP (LADDER SCRAP 110157-02-000) INSULATION, OR USE CARPET PAD (SCRAP) 075233-06.
- 6 ADD TEFLON TAPE 10405-03-000.
- 5 ADD TEFLON TAPE 10405-02-000.
- 4 ADDS THE RING SYSTEM REPAIRS-025697-06-000 INSTRUCTION SHEET.
3. ALL TUBING TO BE SECURED AT 1200 INTERVALS MAXIMUM WITH CLAMP 10495-01-000 AND SCREW 1567010002B AND SCREW 10-12B.
2. TUBING TO BE INSTALLED WITH SUFFICIENT SLOPE TO PROVIDE DRAINAGE TO NEAREST VALVE.
1. PLASTIC FITTINGS TO BE SEALED WITH SEALANT 84456-01-000.

FRONT OF COACH

- (464) TOILET
- (53F) WATER HEATER-ELEC. IGNITION
- (53E) WATER SYS WINTERIZATION PKG
- (08P) INTERIOR UPGRADE-WITHOUT
- (644) GREAT ALASKAN RENTAL PACKAGE

NOTES:

(X-X)  
FOR WATER CALLOUTS SEE DWG NO 116230-01-000

<b>WINNEBAGO</b>		COPYRIGHT 2009 WINNEBAGO INDUSTRIES, INC.	
DFT	ORIG. DATE	ALL DIMENSIONS ARE IN MILLIMETERS	
CHKR		FIRST USED	
P.E.		09 229T	
M.E.			
DSNR			
UNSPECIFIED TOLERANCES ARE:		MATERIAL:	
WHOLE DIM (X)	: 3		
ONE-PLACE (X.X)	: 1.5		
TWO-PLACE (X.XX)	: 0.50		
ANGLE	: 1°		
THIRD ANGLE PROJECTION			
DO NOT SCALE DRAWING			
TITLE: WATER SYSTEM INSTL			
SHEET 1 OF 5	PART NO	165659	REV
REF	1 4/22/2009		

TANK-WATER, 36 GAL  
156167-03-000  
STRAP-TANK, WATER  
118994-10-CHT (2)

PANEL-SHOWER  
78498-01-CHT  
SCREW  
G11-08-16U (3)  
NUT-SPEED-U  
40921-05-000 (4)

WATER HEATER (53F)  
51391-03-000 (53B)  
145541-02-000  
DOOR  
125420-06-CHT  
AL EXTR  
2726-01-210 (2)  
2726-01-212 (2)  
SCREW  
G39-10-169 (18)  
SEALANT  
69640-14-000  
CABLE  
76767-03-000  
SCREW  
G11-06-08B (2)

FAUCET-LAV  
148886-01-CHT (08P)  
165730-01-CHT (644)

FAUCET-GALLEY  
140117-02-CHT (08P)  
149164-01-CHT (644)

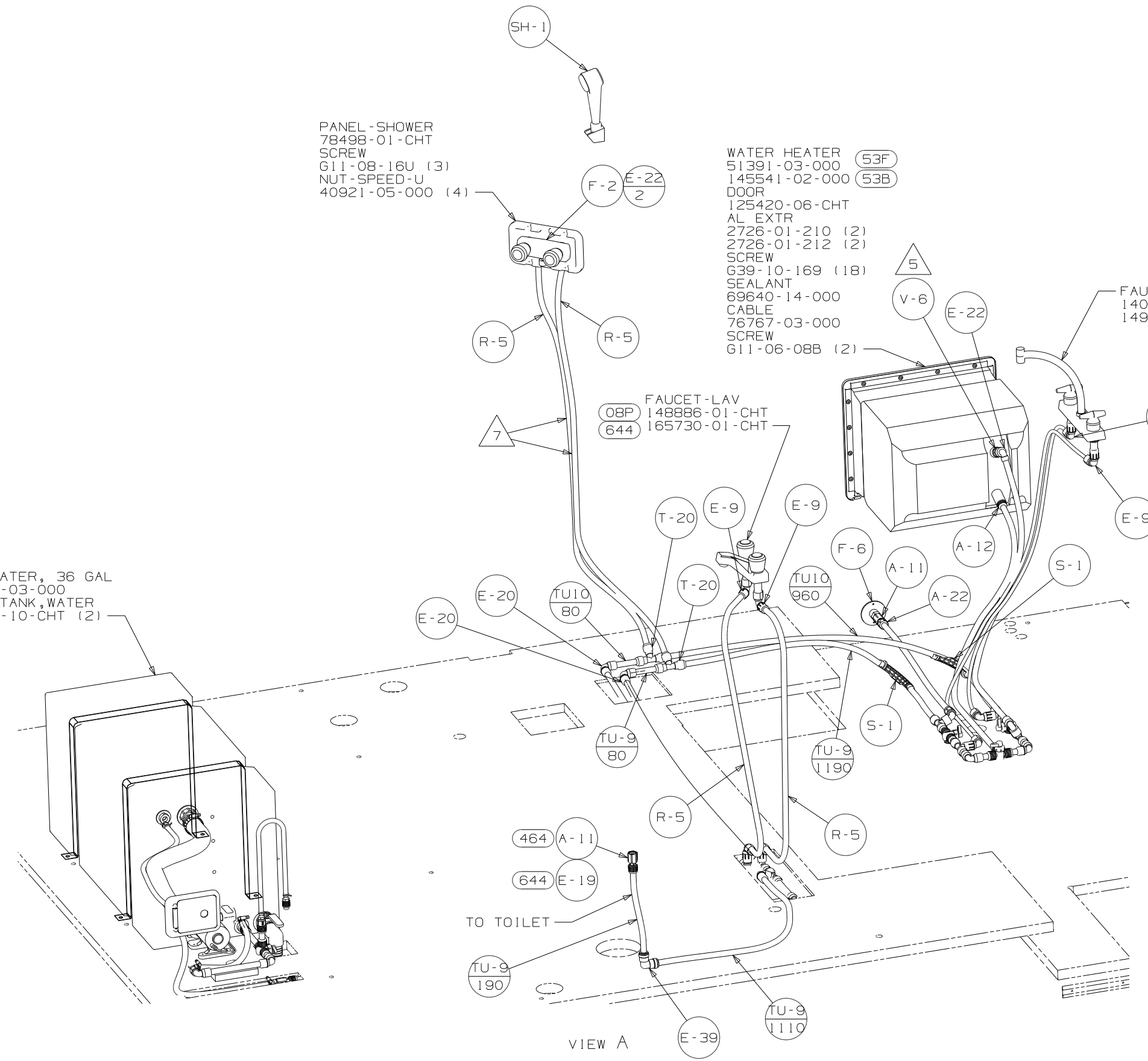

VIEW A

FIRST USED	09 229T
TITLE:	DO NOT SCALE DRAWING
	WATER SYSTEM INSTL
SHEET 2	PART NO 165659 REV

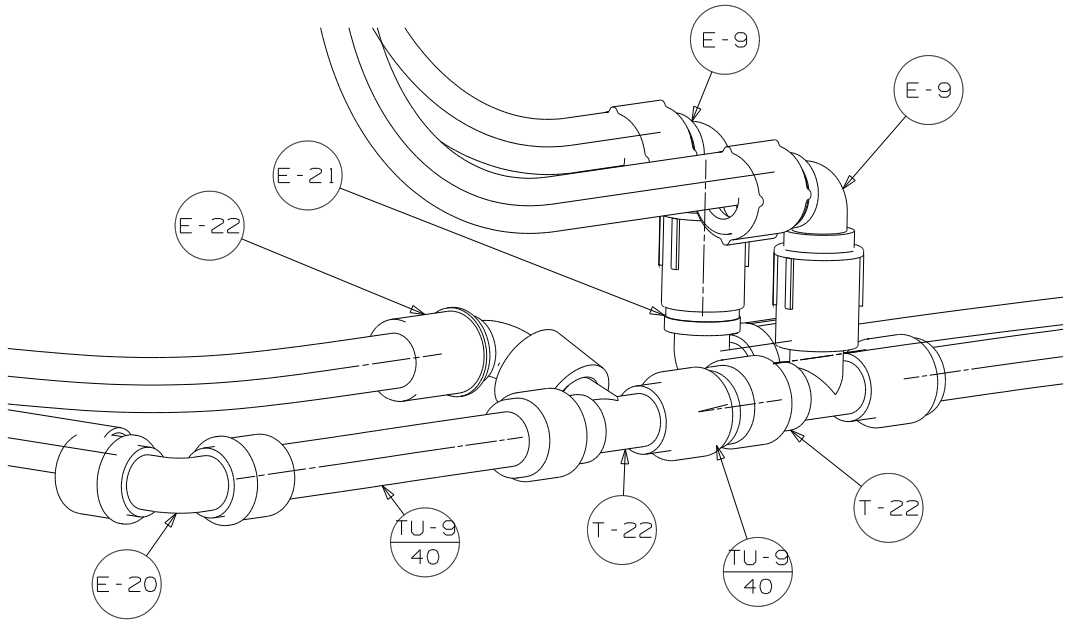

VIEW B  
(SHOWN WITHOUT FLOOR)

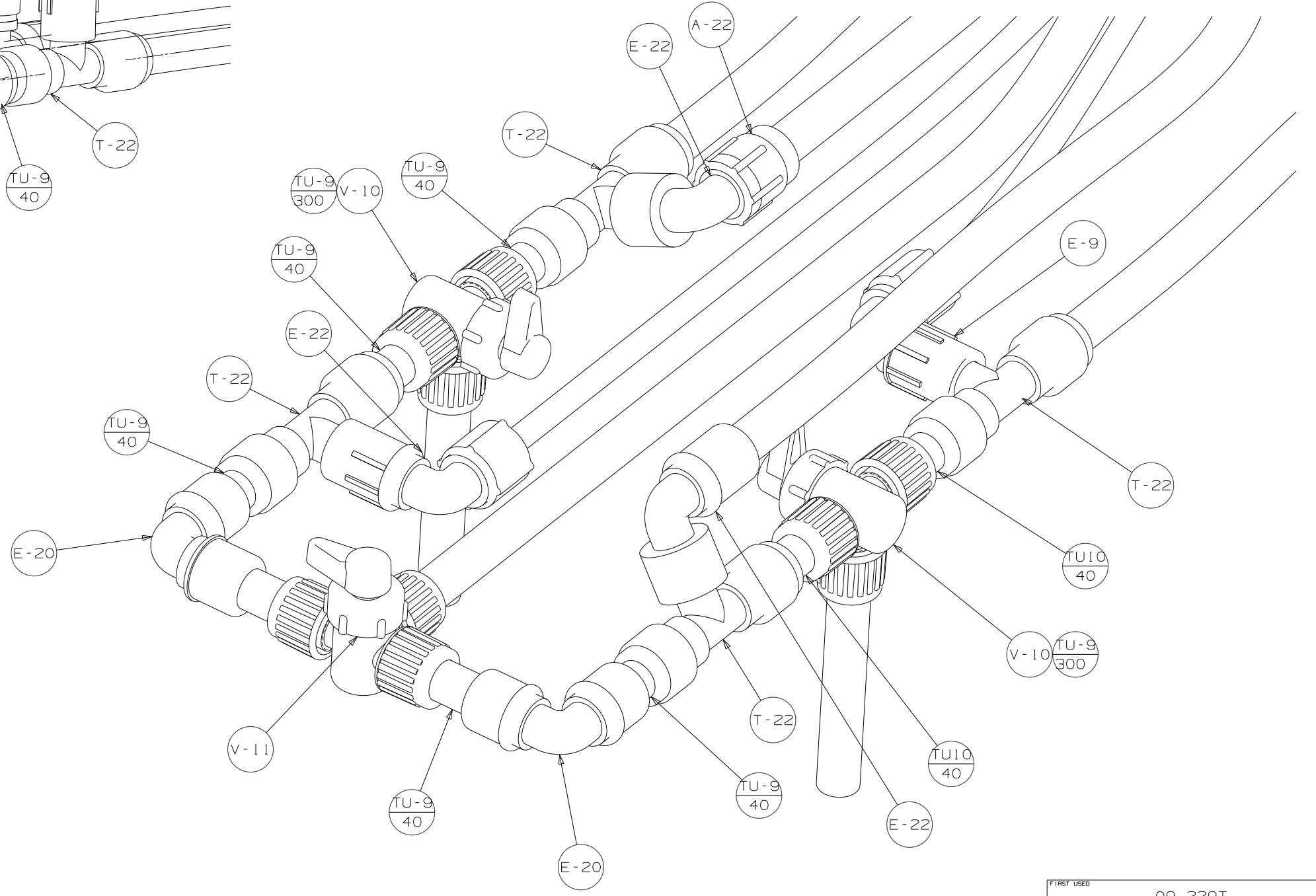

VIEW C  
SHOWN WITHOUT FLOOR

FIRST USED	09 229T
DO NOT SCALE DRAWING	
TITLE	WATER SYSTEM INSTL
SHEET 3	PART NO 165659 REV

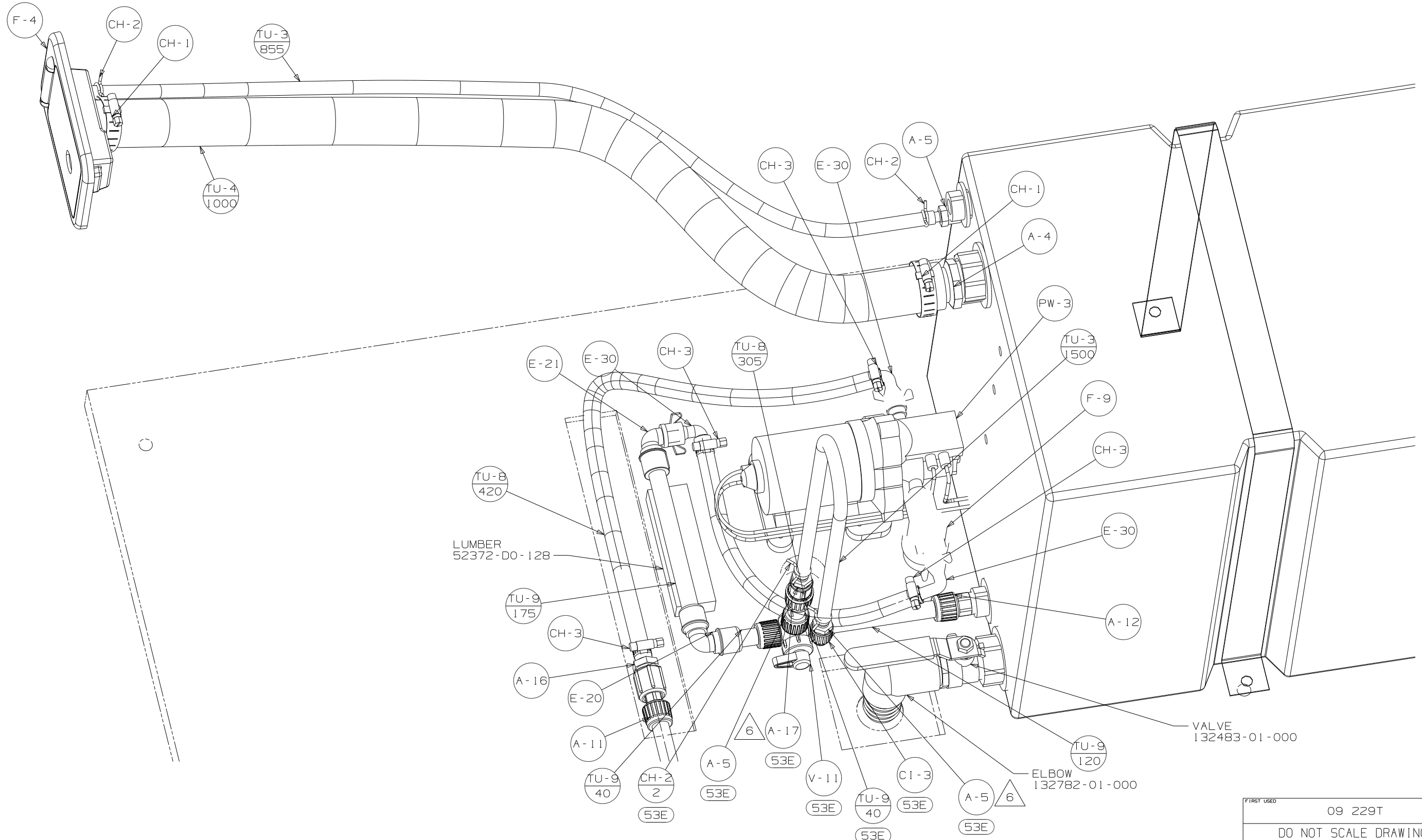

VIEW D

FIRST USED	09 229T
DO NOT SCALE DRAWING	
TITLE:	WATER SYSTEM INSTL
SHEET 4	PART NO 165659 REV



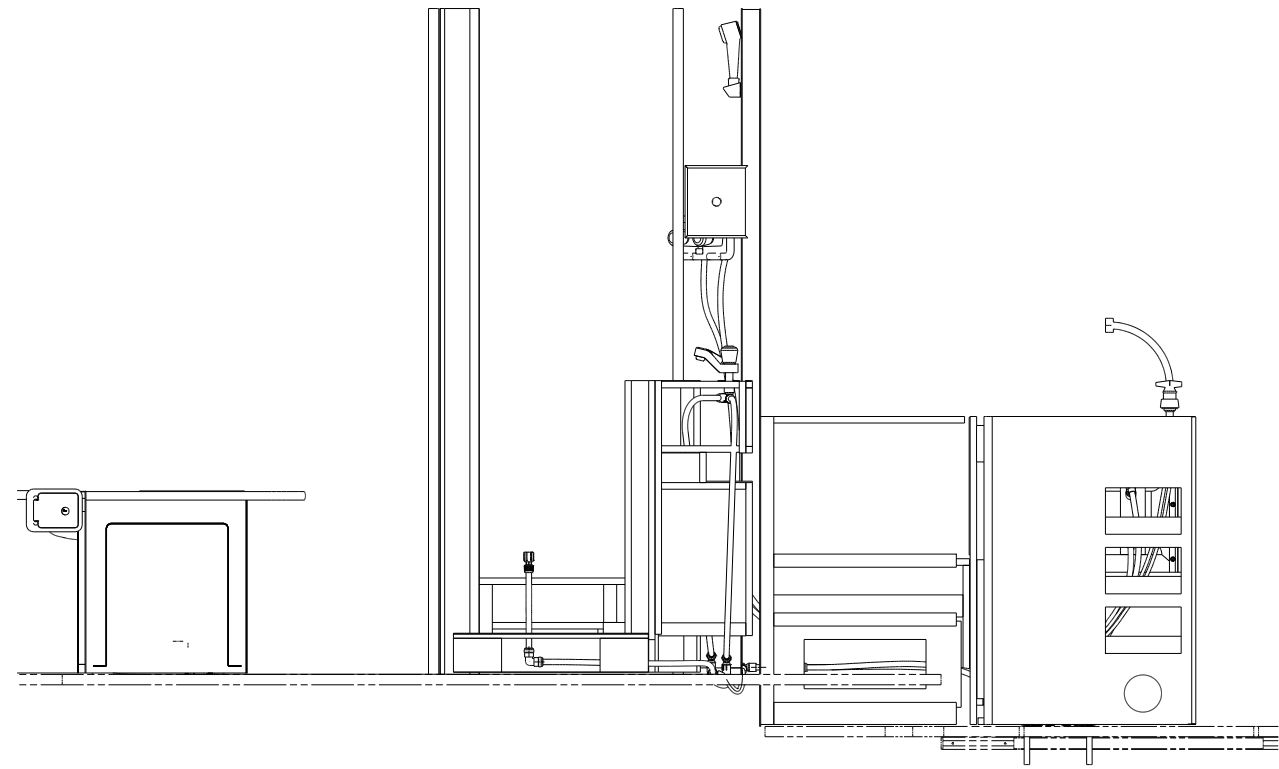

VIEW E

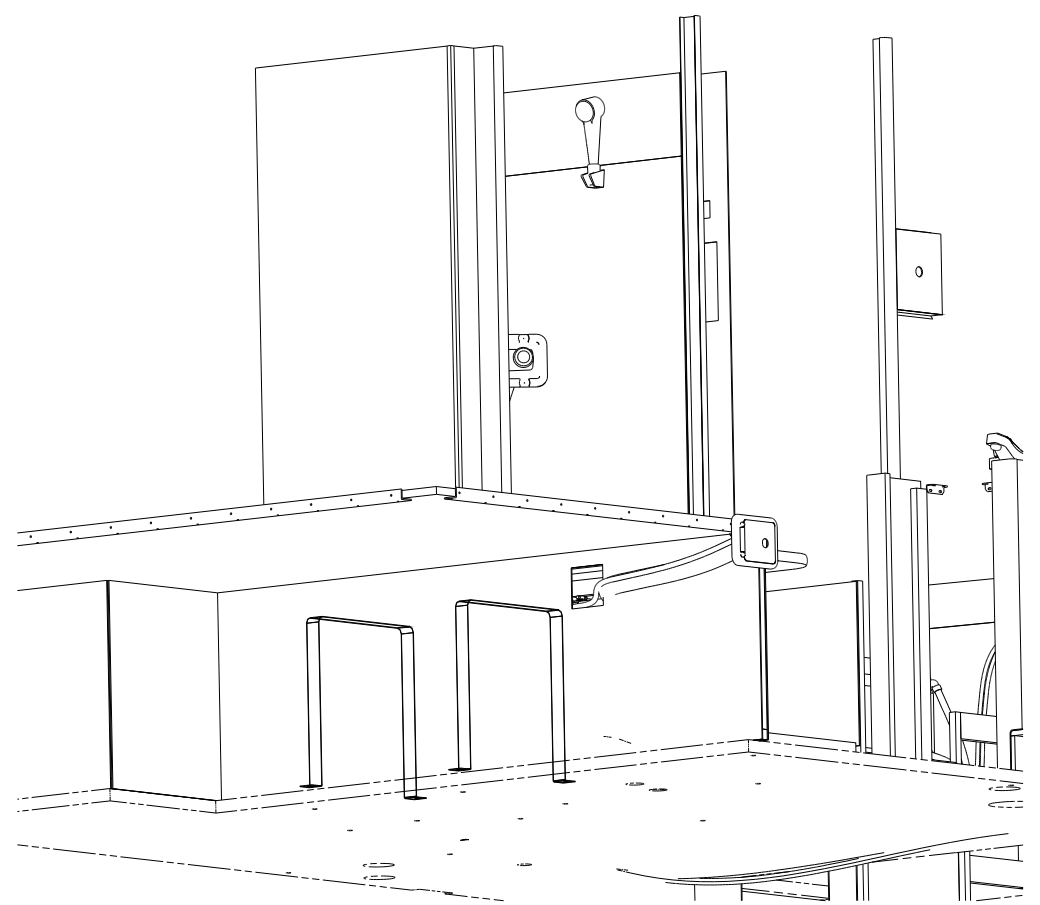

VIEW G

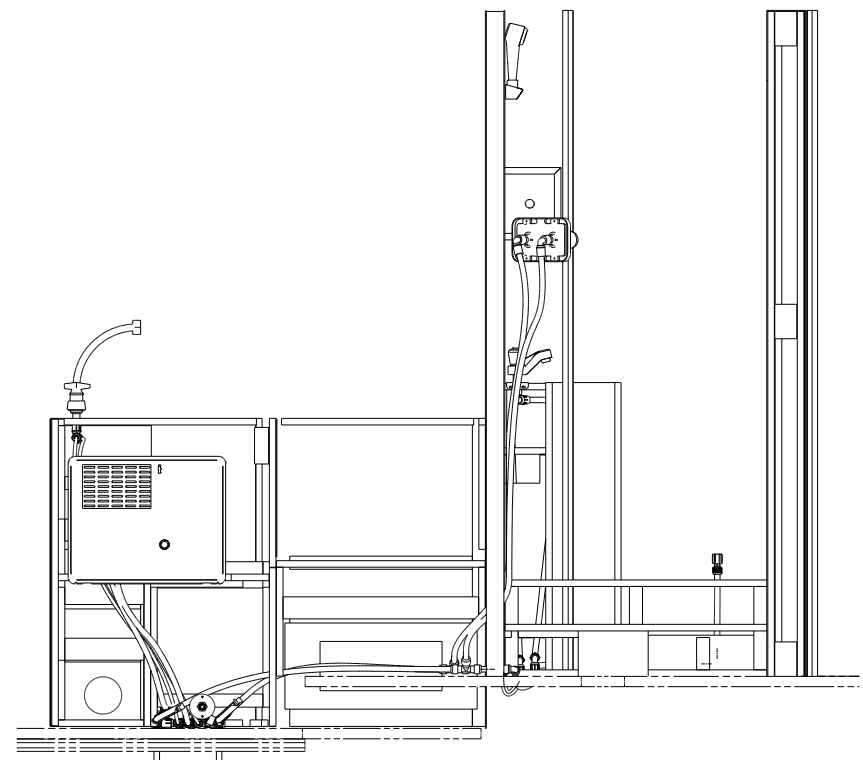

VIEW F

FIRST USED	09 229T
TITLE	DO NOT SCALE DRAWING
SHEET 5	PART NO 165659
	REV