



DANGER

Danger of electrical shock, burns or death. Always remove all power sources before attempting any repair, service or diagnostic work. Power can be present from shore power, generator, inverter or battery. All power sources must be disabled and secured before performing any service.



CAUTION

If you lack the skills, tools or equipment to perform diagnostic or repair work leave such work to an authorized Winnebago Industries dealer or other qualified shop.

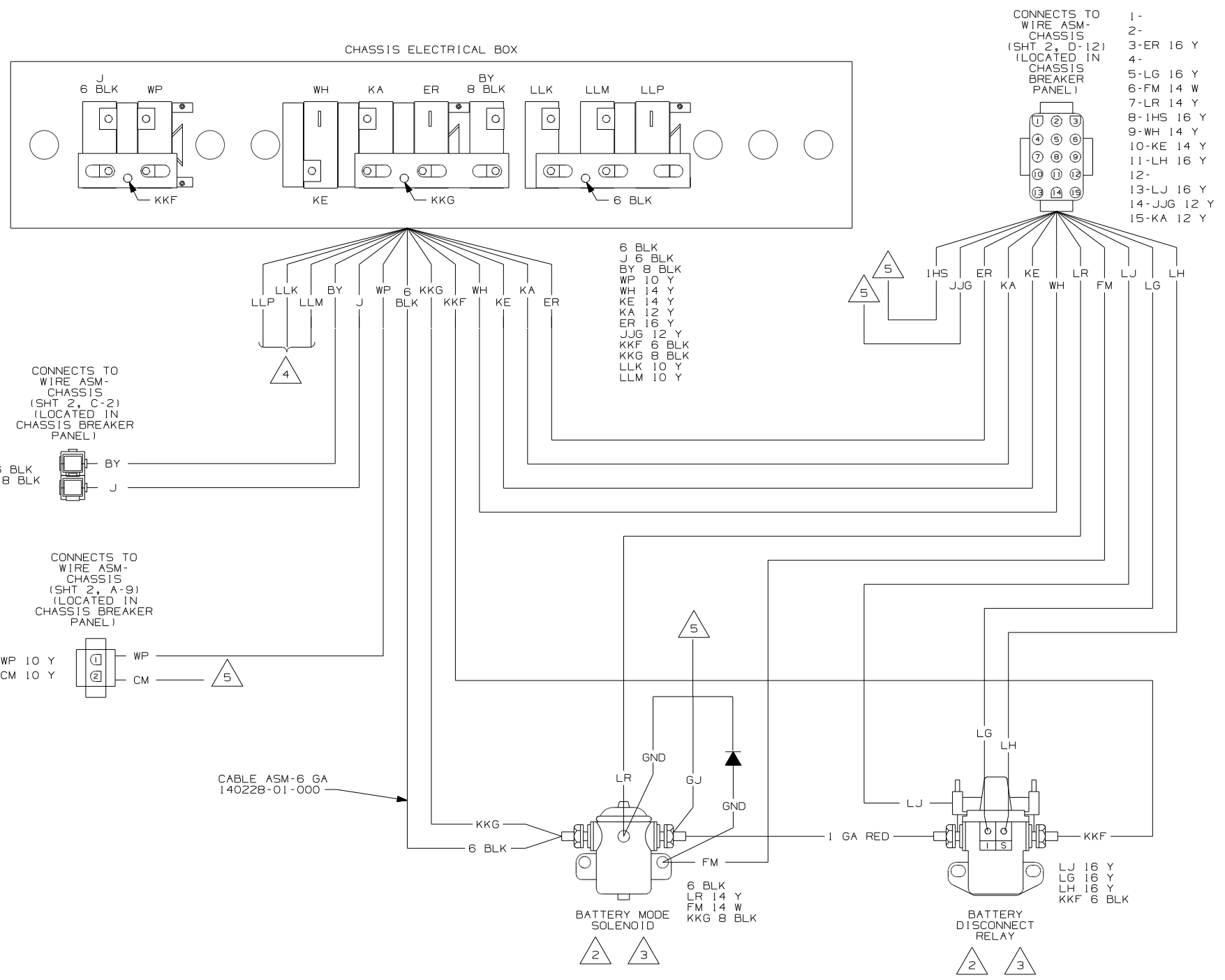

- △ 5 CIRCUIT IS NOT USED.
- △ 4 WIRE IS FROM WIRE ASM-SLIDEOUT POWER.
- △ 3 SEE WIRING DIAGRAM-AUTO FOR ADDITIONAL INFORMATION.
- △ 2 SEE MANUFACTURERS DIAGRAM FOR ADDITIONAL INFORMATION.

NOTES:
1. SPLICES ARE THEORETICAL AND MAY DIFFER IN THE HARNESS.

WIRING DIAGRAM-ELECTRICAL BOX
(WIRE ASM 124125-03 REV-T)

WINNEBAGO		COPYRIGHT 2006 WINNEBAGO INDUSTRIES, INC.	
DFTR	ORIG. DATE	ALL DIMENSIONS ARE IN MILLIMETERS	
CHKR		FIRST USED	
P.E.		08 D29R	
M.E.		UNSPECIFIED TOLERANCES ARE:	
DSNR		MATERIAL:	
		WHOLE DIM (X)	:
		ONE-PLACE (X.X)	:
		TWO-PLACE (X.XX)	:
		ANGLE	:
		THIRD ANGLE PROJECTION	⊕
DO NOT SCALE DRAWING			
TITLE: WIRING DIAGRAM-BODY, 12V			
SHEET 1 of 7	PART NO	162633	REV
REF:	1 11/2/2007		

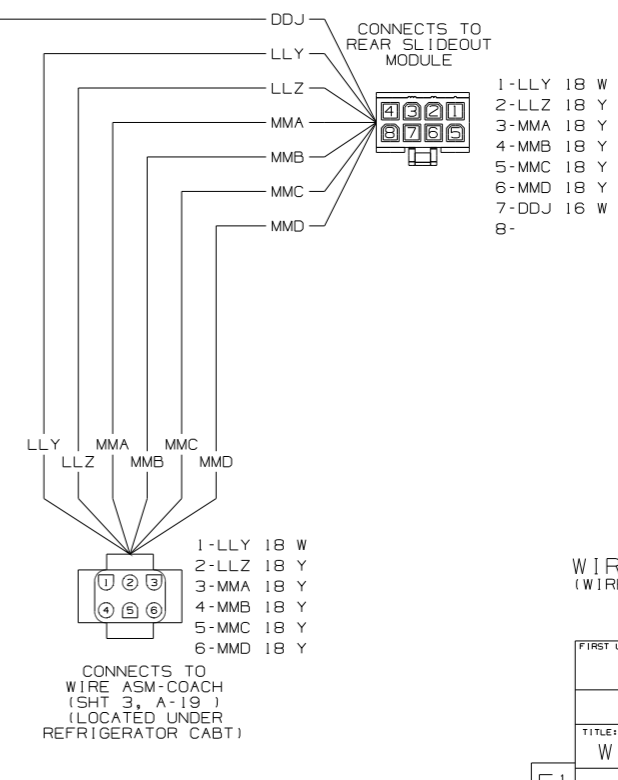
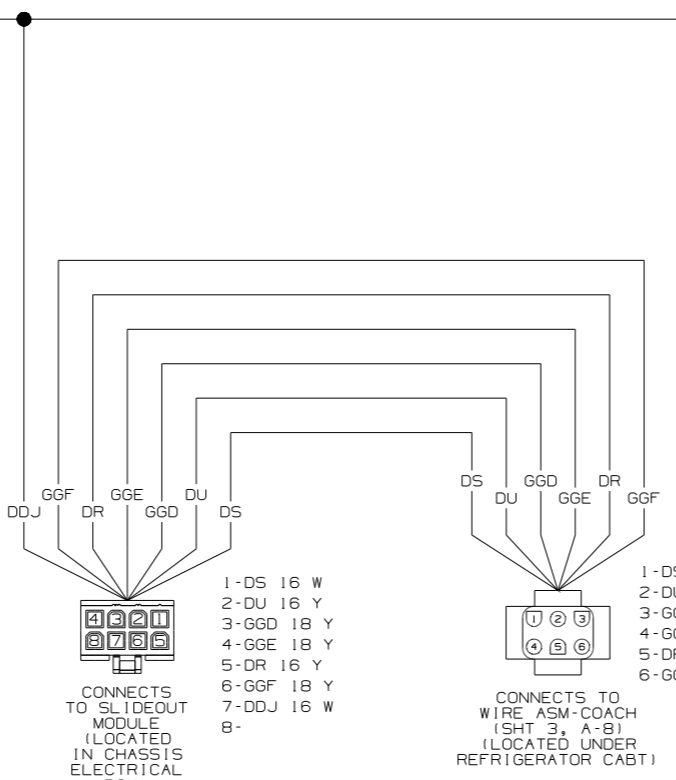
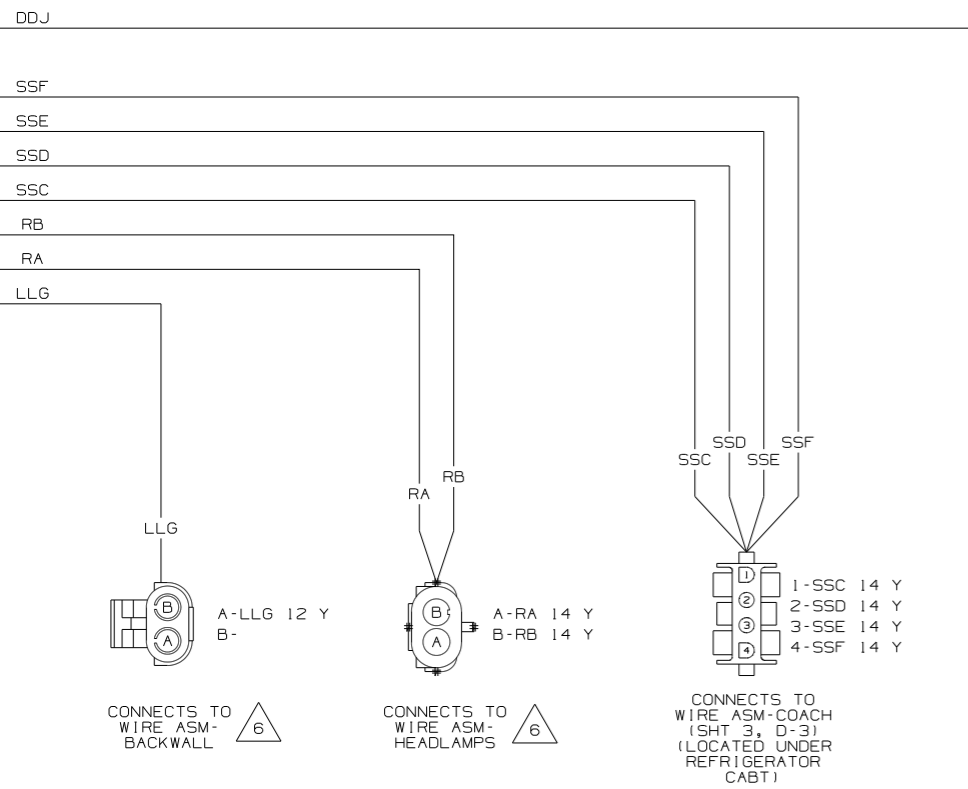
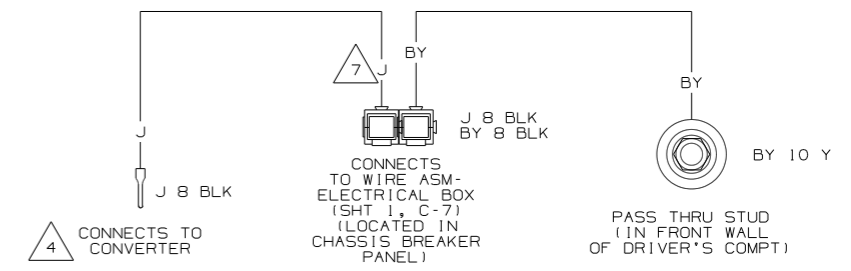
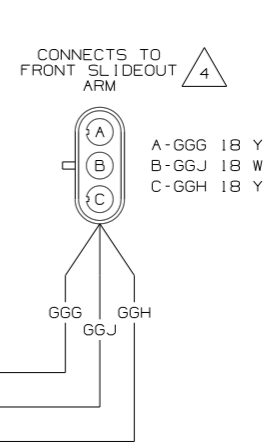
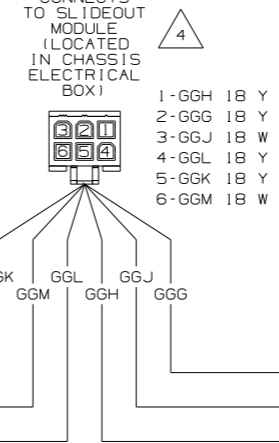
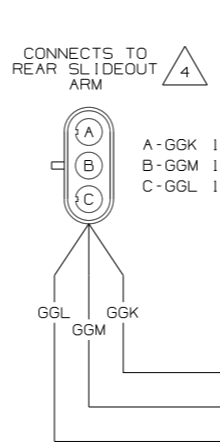
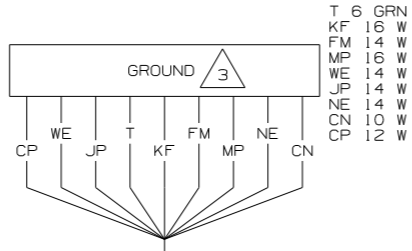
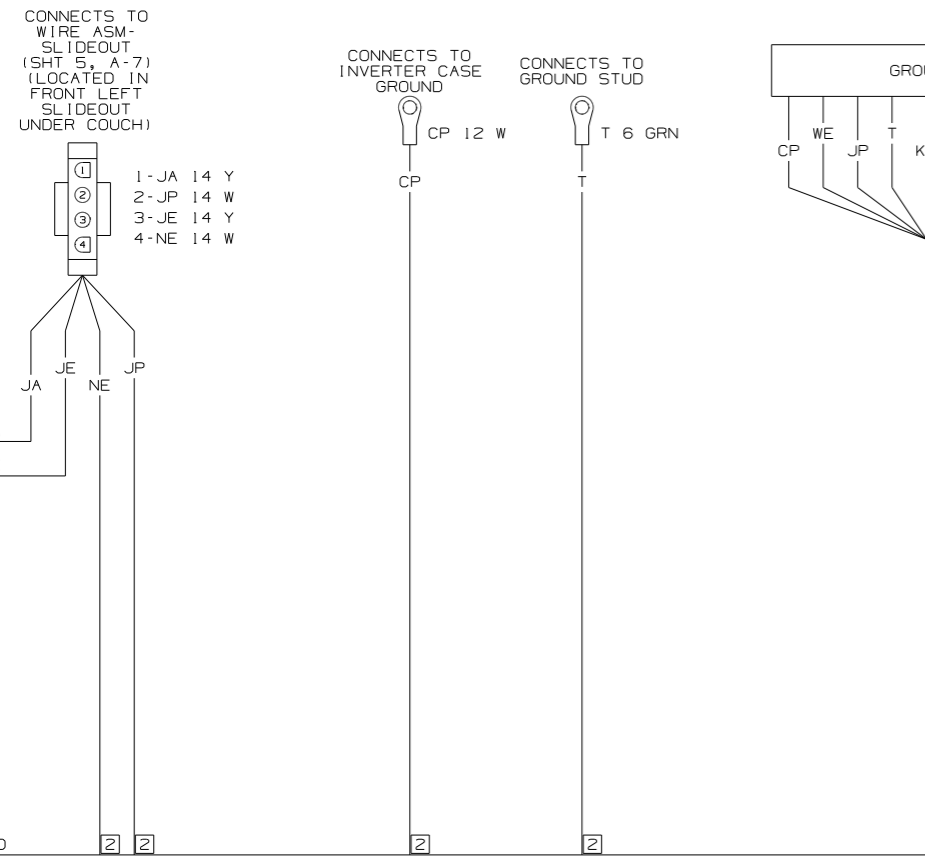

WIRING DIAGRAM-CHASSIS (WIRE ASM 162710 REV-D)

FIRST USED	08 D29R	
DO NOT SCALE DRAWING		
TITLE:	WIRING DIAGRAM-BODY, 12V	
SHEET 2	PART NO	162633

D
C
B
A

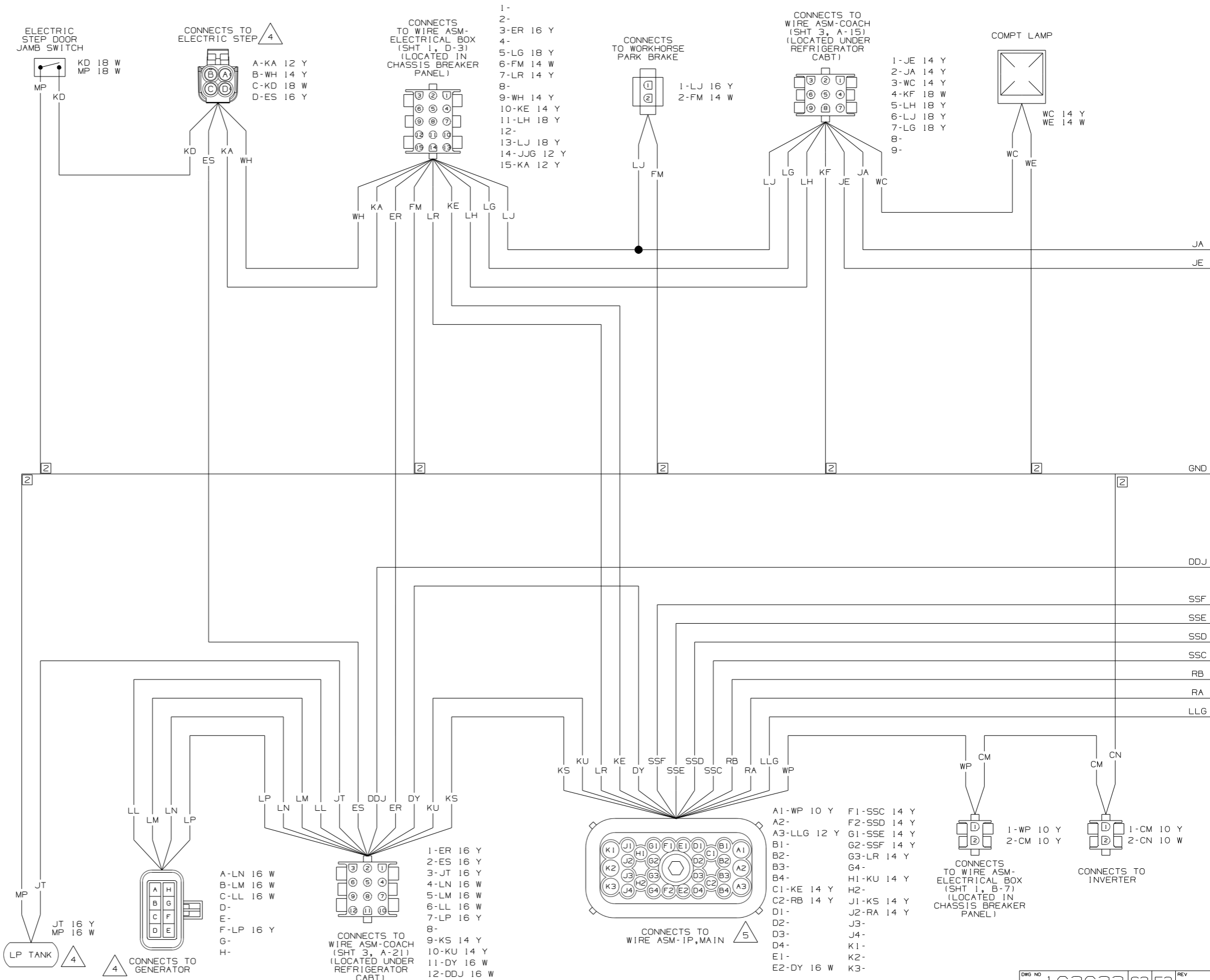

- 7 WIRE IS MARKED WITH YELLOW TAPE.
 - 6 SEE WIRING DIAGRAM-AUTO LAMPS FOR ADDITIONAL INFORMATION.
 - 5 SEE WIRING DIAGRAM-AUTO FOR ADDITIONAL INFORMATION.
 - 4 SEE MANUFACTURERS DIAGRAM FOR ADDITIONAL INFORMATION.
 - 3 GROUNDS ARE SHOWN AS A SINGLE LINE FOR EASE IN TRACING. EACH GROUND CIRCUIT IS SEPERATE IN THE HARNESS.
 - 2 NOT A SPLICE POINT. INDICATES ENTRY INTO WIRING HARNESS.
- NOTES:
 1. SPLICES ARE THEORETICAL AND MAY DIFFER IN THE HARNESS.

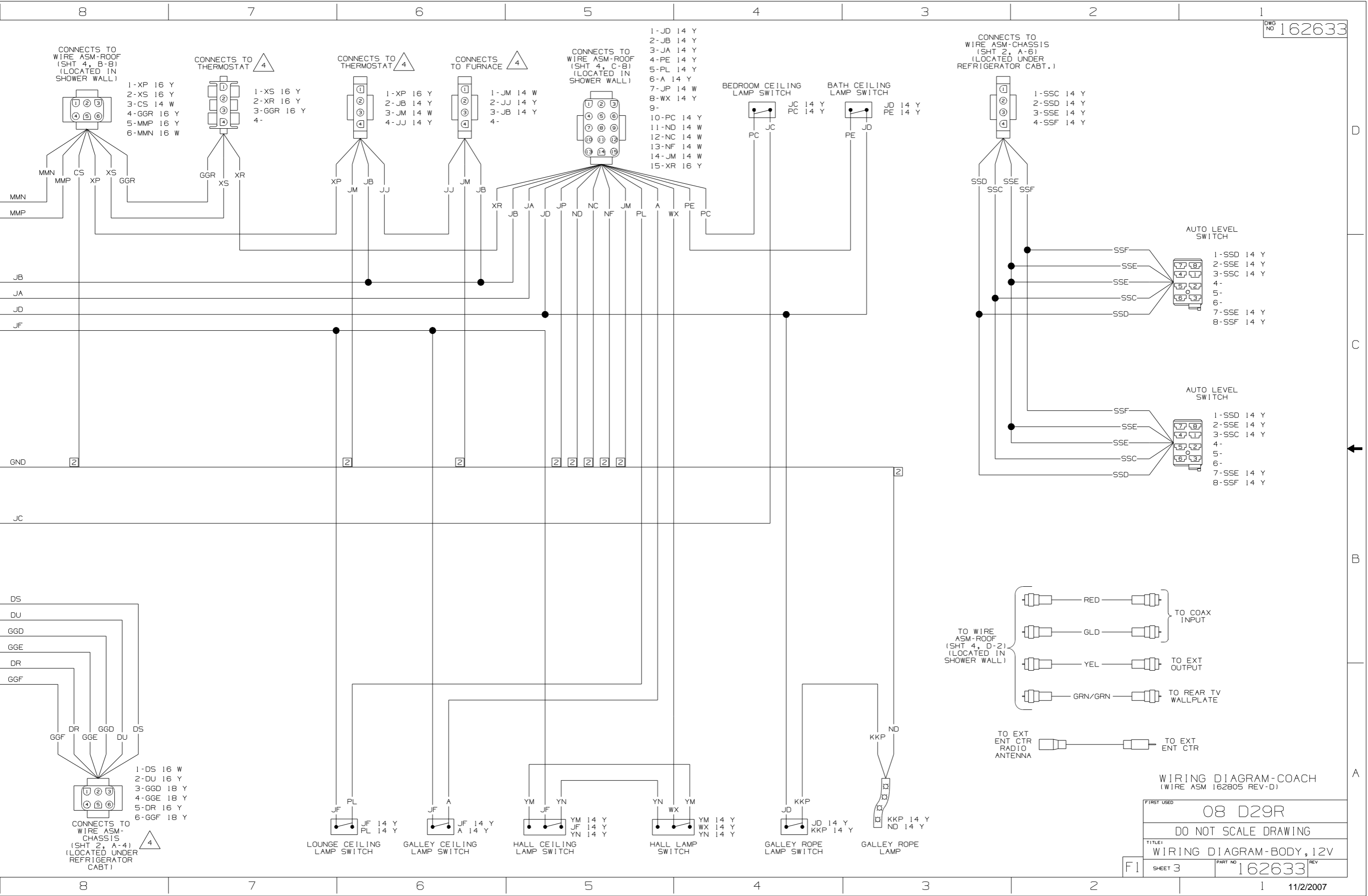

CONNECTS TO WIRE ASM-ROOF (SHT 4, B-8) (LOCATED IN SHOWER WALL)

CONNECTS TO THERMOSTAT (4)

CONNECTS TO THERMOSTAT (4)

CONNECTS TO FURNACE (4)

CONNECTS TO WIRE ASM-ROOF (SHT 4, C-8) (LOCATED IN SHOWER WALL)

CONNECTS TO WIRE ASM-CHASSIS (SHT 2, A-6) (LOCATED UNDER REFRIGERATOR CABT.)

- 1-JD 14 Y
- 2-JB 14 Y
- 3-JA 14 Y
- 4-PE 14 Y
- 5-PL 14 Y
- 6-A 14 Y
- 7-JP 14 W
- 8-WX 14 Y
- 9-
- 10-PC 14 Y
- 11-ND 14 W
- 12-NC 14 W
- 13-NF 14 W
- 14-JM 14 W
- 15-XR 16 Y

BEDROOM CEILING LAMP SWITCH

BATH CEILING LAMP SWITCH

AUTO LEVEL SWITCH

AUTO LEVEL SWITCH

- 1-SSD 14 Y
- 2-SSE 14 Y
- 3-SSC 14 Y
- 4-
- 5-
- 6-
- 7-SSE 14 Y
- 8-SSF 14 Y

- 1-SSD 14 Y
- 2-SSE 14 Y
- 3-SSC 14 Y
- 4-
- 5-
- 6-
- 7-SSE 14 Y
- 8-SSF 14 Y

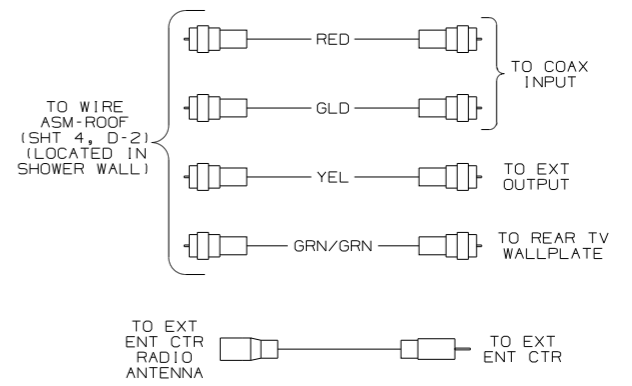

WIRING DIAGRAM-COACH (WIRE ASM 162805 REV-D)

FIRST USED	08 D29R	
DO NOT SCALE DRAWING		
TITLE	WIRING DIAGRAM-BODY, 12V	
SHEET 3	PART NO	162633
		REV

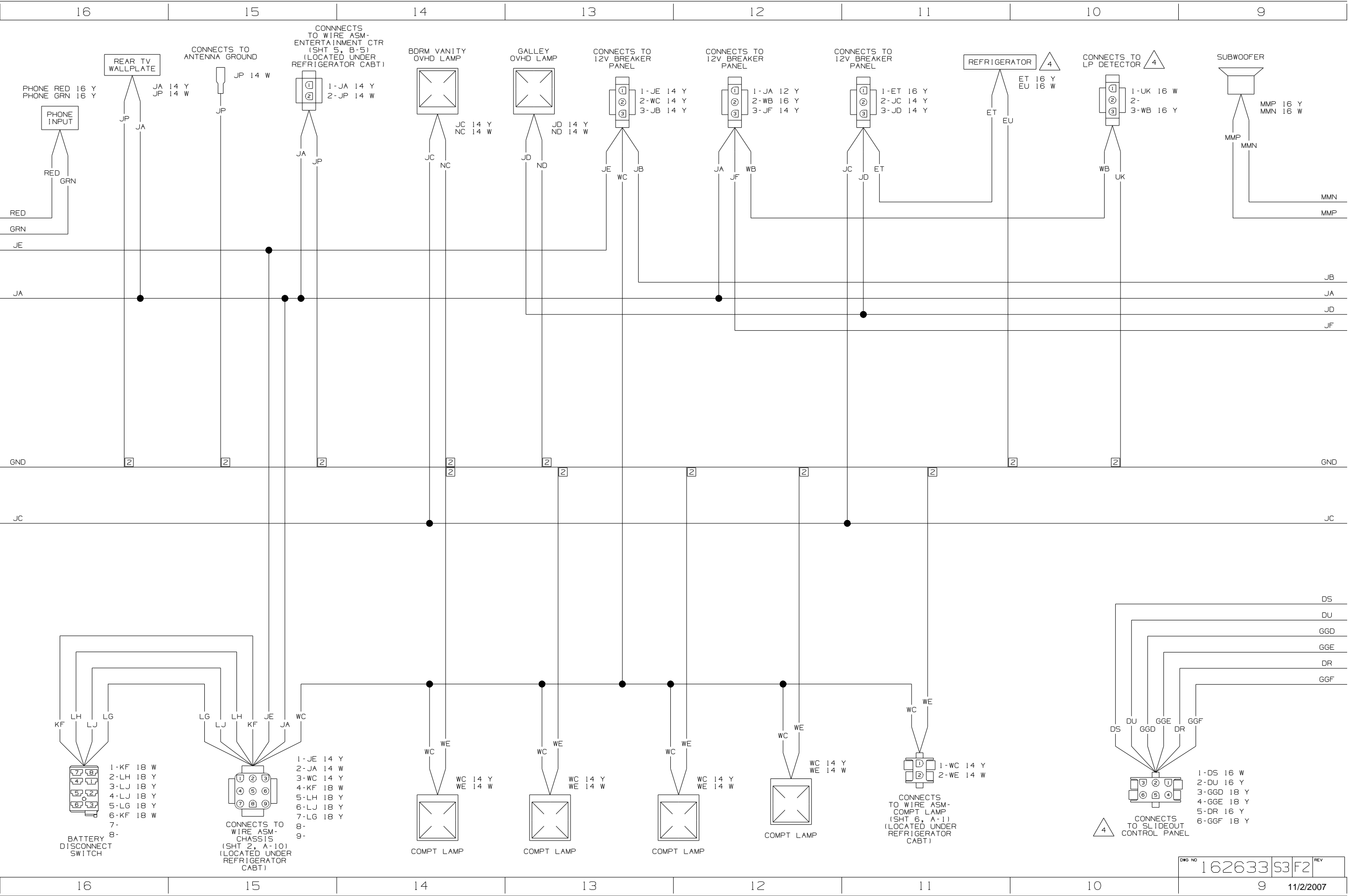

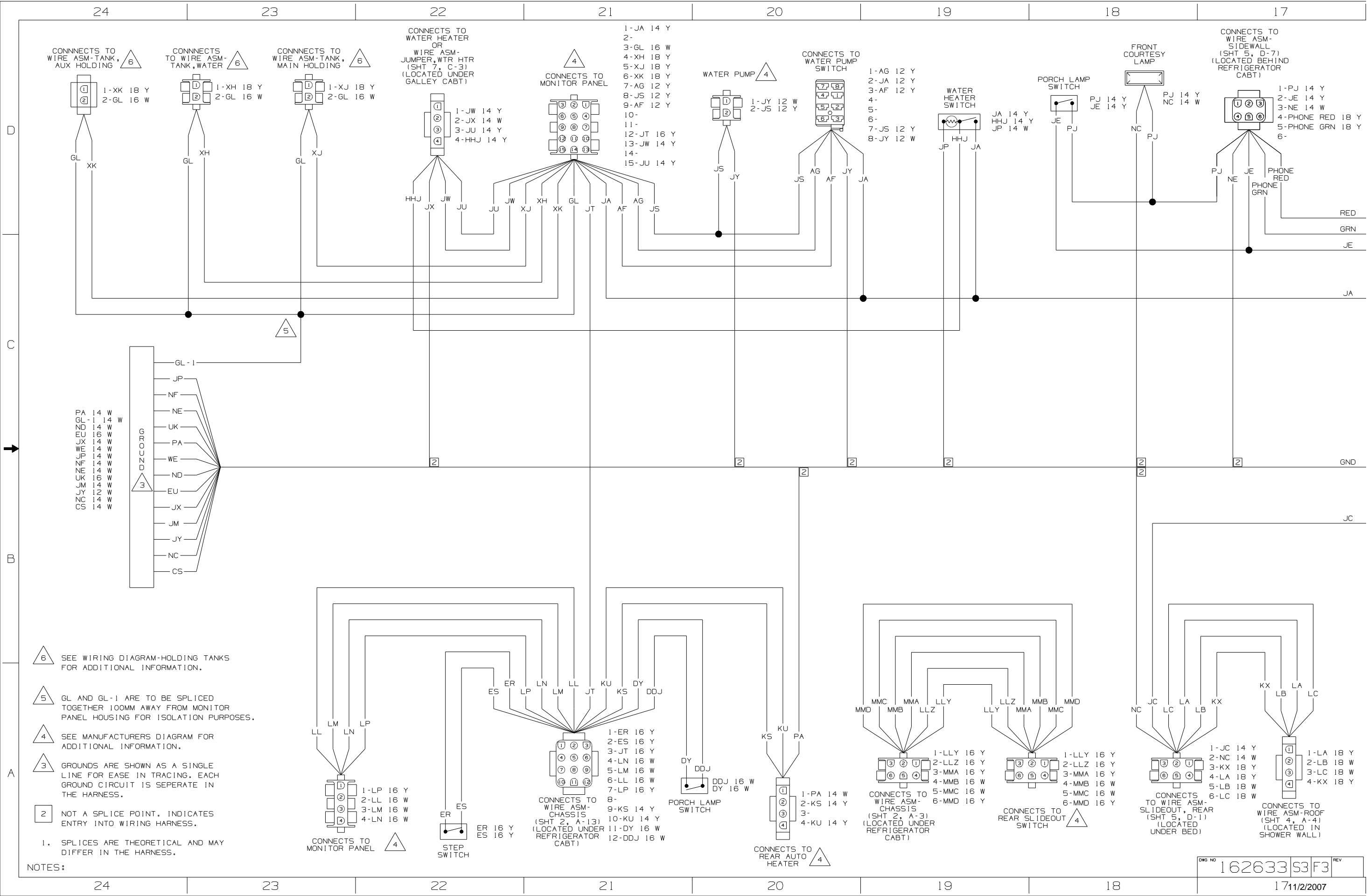

- 6 SEE WIRING DIAGRAM-HOLDING TANKS FOR ADDITIONAL INFORMATION.
- 5 GL AND GL-1 ARE TO BE SPLICED TOGETHER 100MM AWAY FROM MONITOR PANEL HOUSING FOR ISOLATION PURPOSES.
- 4 SEE MANUFACTURERS DIAGRAM FOR ADDITIONAL INFORMATION.
- 3 GROUNDS ARE SHOWN AS A SINGLE LINE FOR EASE IN TRACING. EACH GROUND CIRCUIT IS SEPERATE IN THE HARNESS.
- 2 NOT A SPLICE POINT. INDICATES ENTRY INTO WIRING HARNESS.
1. SPLICES ARE THEORETICAL AND MAY DIFFER IN THE HARNESS.

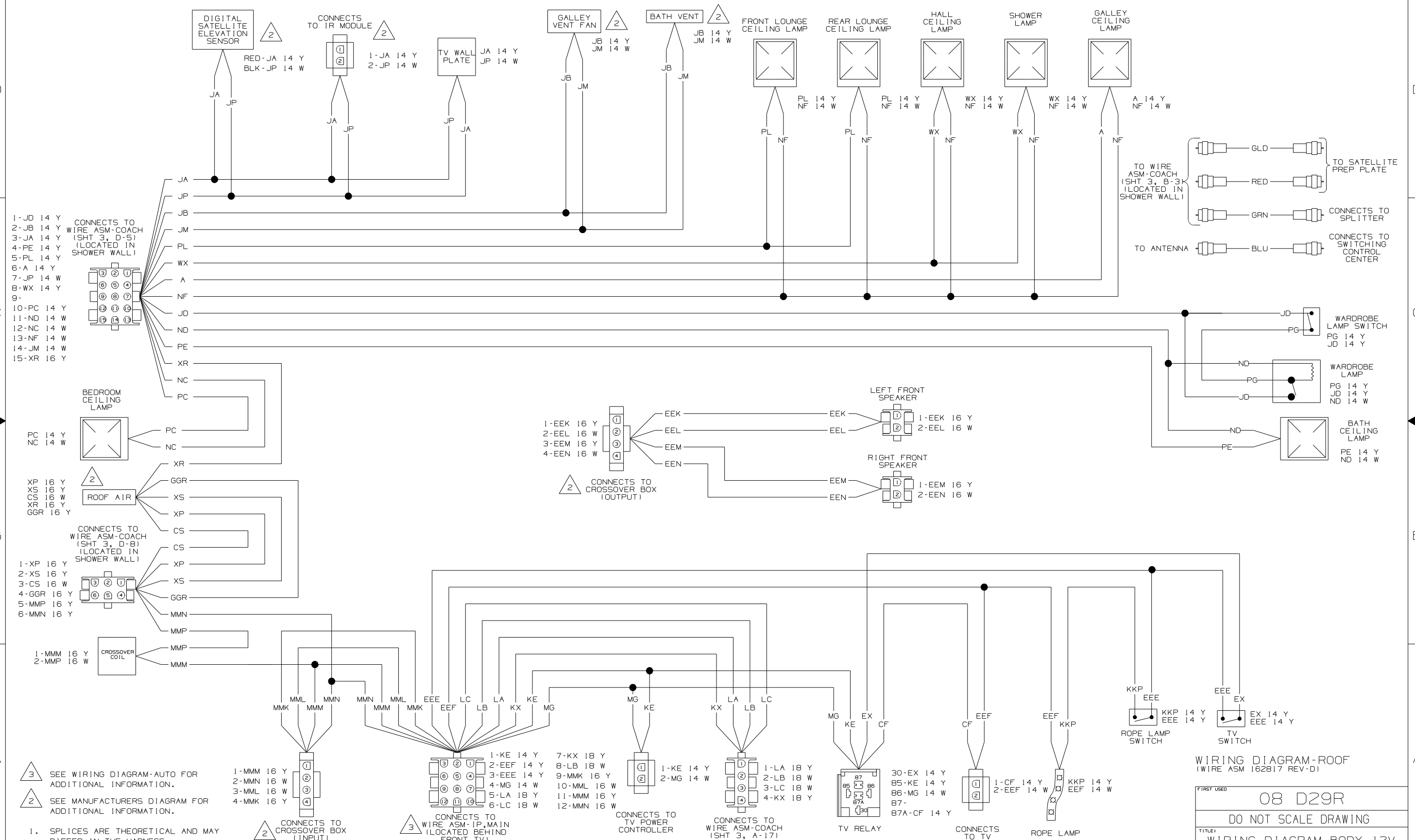

- 1-JD 14 Y
- 2-JB 14 Y
- 3-JA 14 Y
- 4-PE 14 Y
- 5-PL 14 Y
- 6-A 14 Y
- 7-JP 14 W
- 8-WX 14 Y
- 9-
- 10-PC 14 Y
- 11-ND 14 W
- 12-NC 14 W
- 13-NF 14 W
- 14-JM 14 W
- 15-XR 16 Y

- XP 16 Y
- XS 16 Y
- CS 16 W
- XR 16 Y
- GGR 16 Y

- 1-XP 16 Y
- 2-XS 16 Y
- 3-CS 16 W
- 4-GGR 16 Y
- 5-MMP 16 Y
- 6-MMN 16 Y

- 1-MMM 16 Y
- 2-MMP 16 W

NOTES:

3 SEE WIRING DIAGRAM-AUTO FOR ADDITIONAL INFORMATION.

2 SEE MANUFACTURERS DIAGRAM FOR ADDITIONAL INFORMATION.

1. SPLICES ARE THEORETICAL AND MAY DIFFER IN THE HARNESS.

- 1-MMM 16 Y
- 2-MMN 16 W
- 3-MML 16 W
- 4-MMK 16 Y

- 1-KE 14 Y
- 2-EEF 14 Y
- 3-EEE 14 Y
- 4-MG 14 W
- 5-LA 18 Y
- 6-LC 18 W
- 7-KX 18 Y
- 8-LB 18 W
- 9-MMK 16 Y
- 10-MML 16 W
- 11-MMN 16 Y
- 12-MMN 16 W

- 1-KE 14 Y
- 2-MG 14 W

- 1-LA 18 Y
- 2-LB 18 W
- 3-LC 18 W
- 4-KX 18 Y

- 30-EX 14 Y
- 85-KE 14 Y
- 86-MG 14 W
- 87-
- 87A-CF 14 Y

- 1-CF 14 Y
- 2-EEF 14 W
- KKP 14 Y
- EEF 14 W

WIRING DIAGRAM-ROOF
(WIRE ASM 162817 REV-D)

FIRST USED	08 D29R
DO NOT SCALE DRAWING	
TITLE: WIRING DIAGRAM-BODY, 12V	
SHEET 4	PART NO 162633 REV

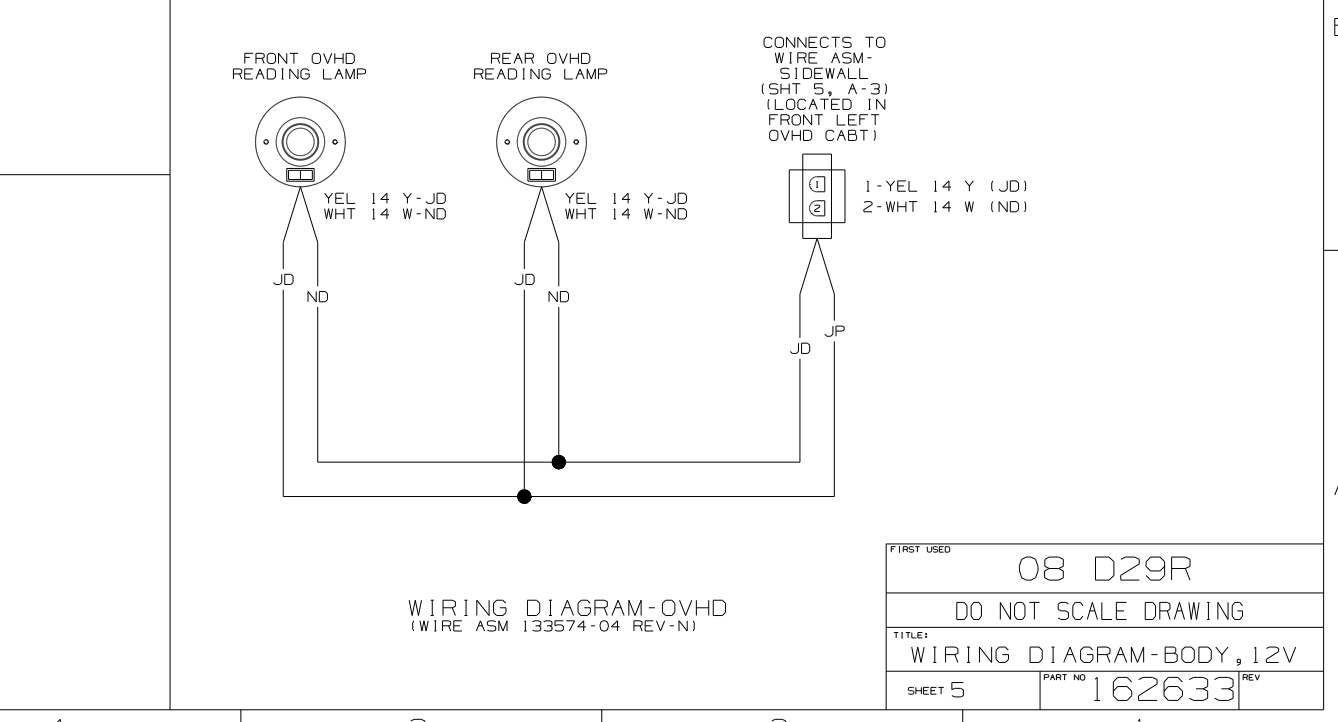
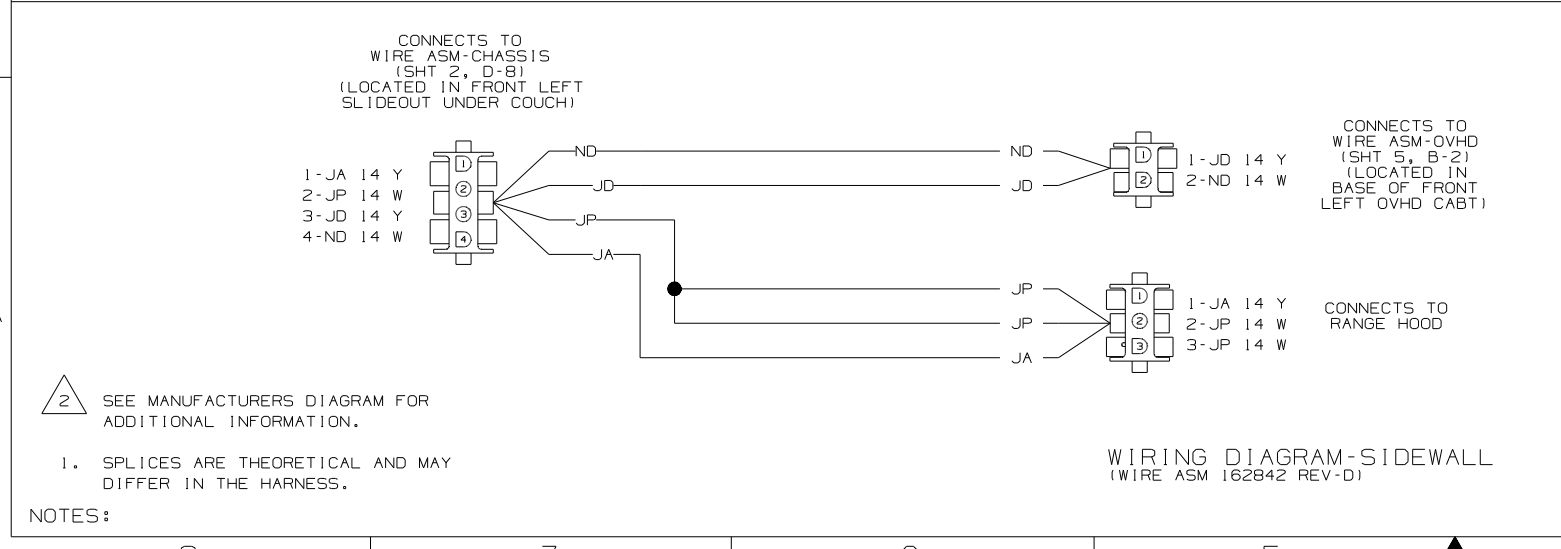
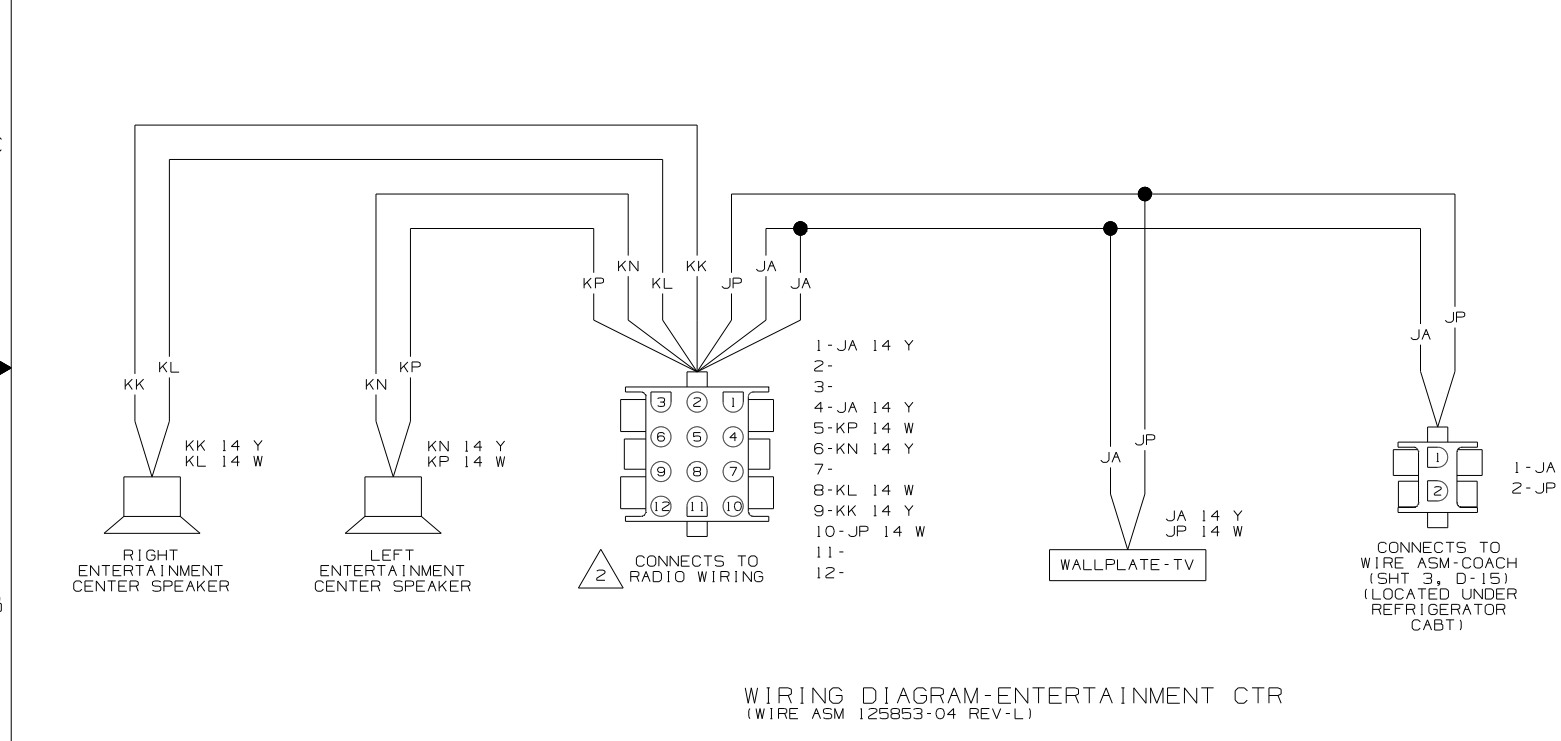
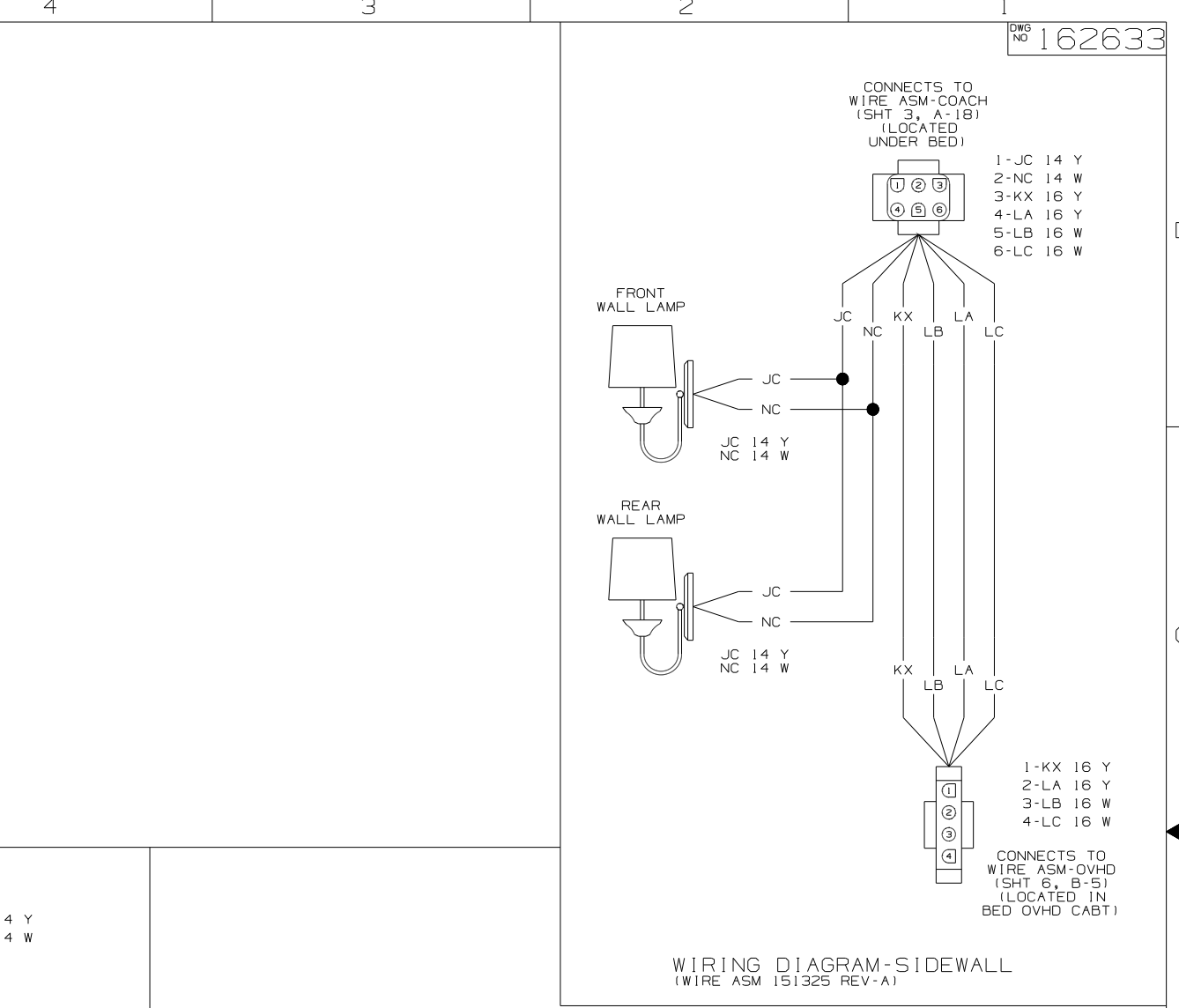
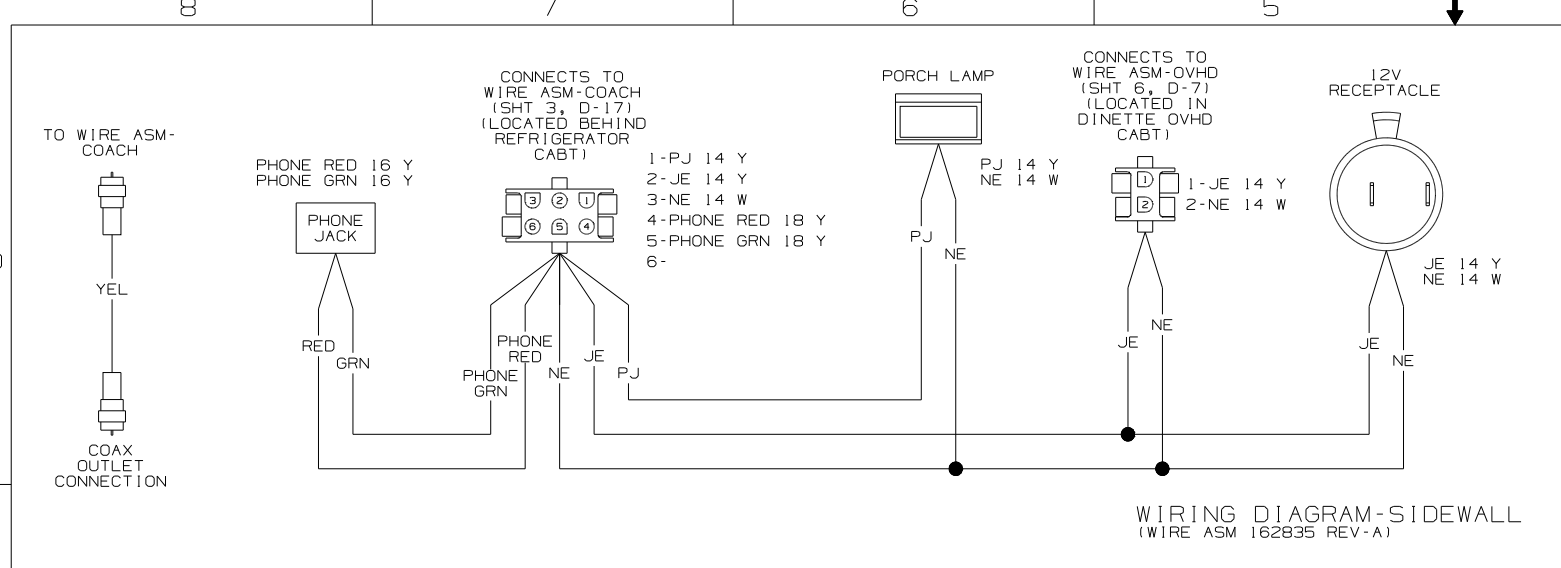

SEE MANUFACTURERS DIAGRAM FOR ADDITIONAL INFORMATION.

1. SPLICES ARE THEORETICAL AND MAY DIFFER IN THE HARNESS.

FIRST USED	08 D29R
DO NOT SCALE DRAWING	
TITLE: WIRING DIAGRAM-BODY, 12V	
SHEET 5	PART NO 162633 REV

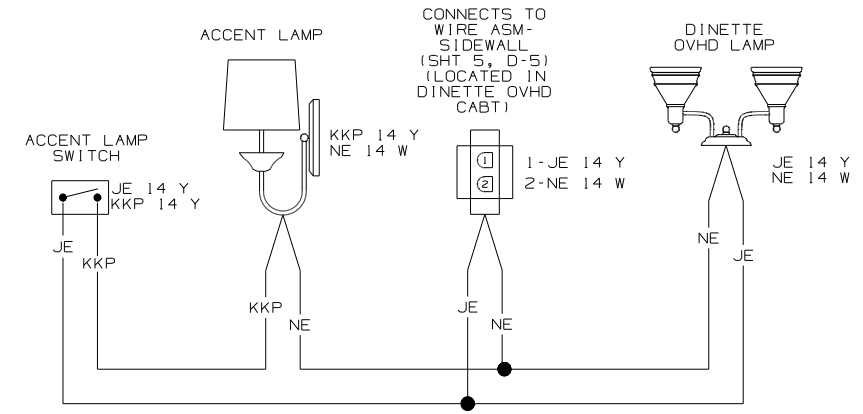

WIRING DIAGRAM-OVHD
(WIRE ASM 162783 REV-A)

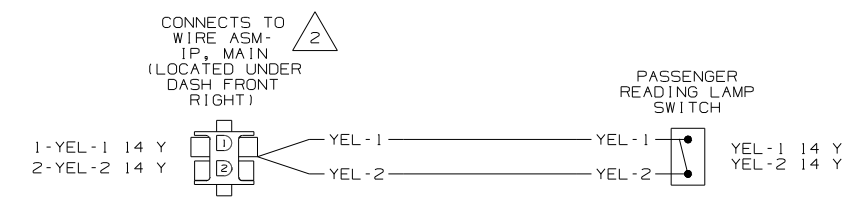

WIRING DIAGRAM-EXTENSION, 2 PIN
(WIRE ASM 147579-02 REV-A)

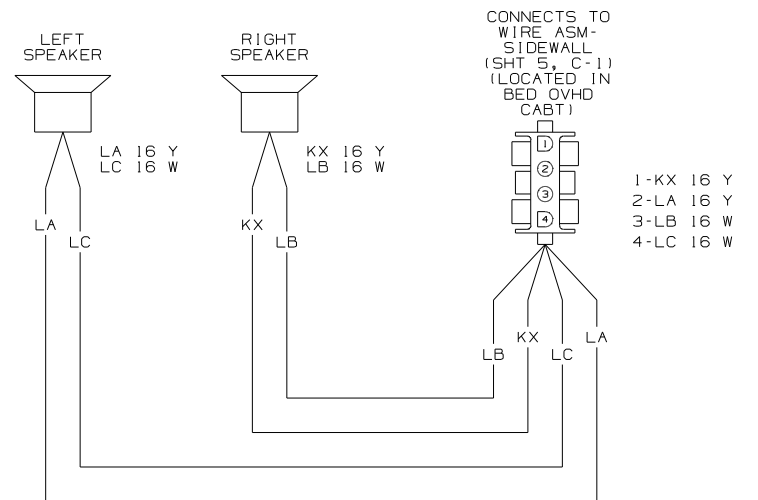

WIRING DIAGRAM-OVHD
(WIRE ASM 151307 REV-A)

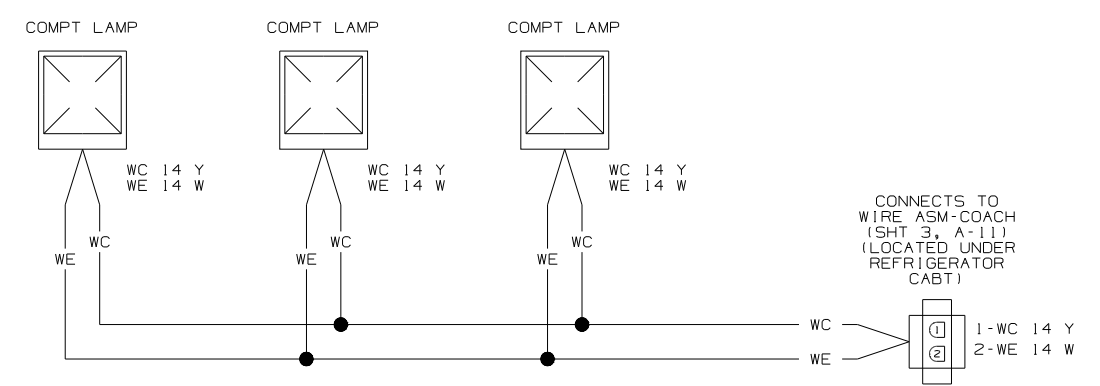

WIRING DIAGRAM-COMPT LAMP
(WIRE ASM 149929 REV-C)

SEE WIRING DIAGRAM-AUTO FOR ADDITIONAL INFORMATION.

- 1. SPLICES ARE THEORETICAL AND MAY DIFFER IN THE HARNESS.

NOTES:

FIRST USED	08 D29R
TITLE	DO NOT SCALE DRAWING
	WIRING DIAGRAM-BODY, 12V
SHEET 6	PART NO 162633 REV

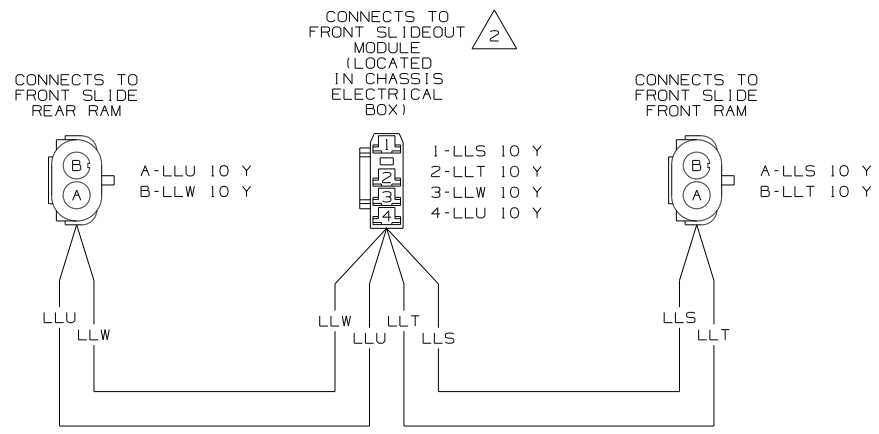

WIRING DIAGRAM-SLIDEOUT RAMS,FRONT
(WIRE ASM 149553-03 REV-V)

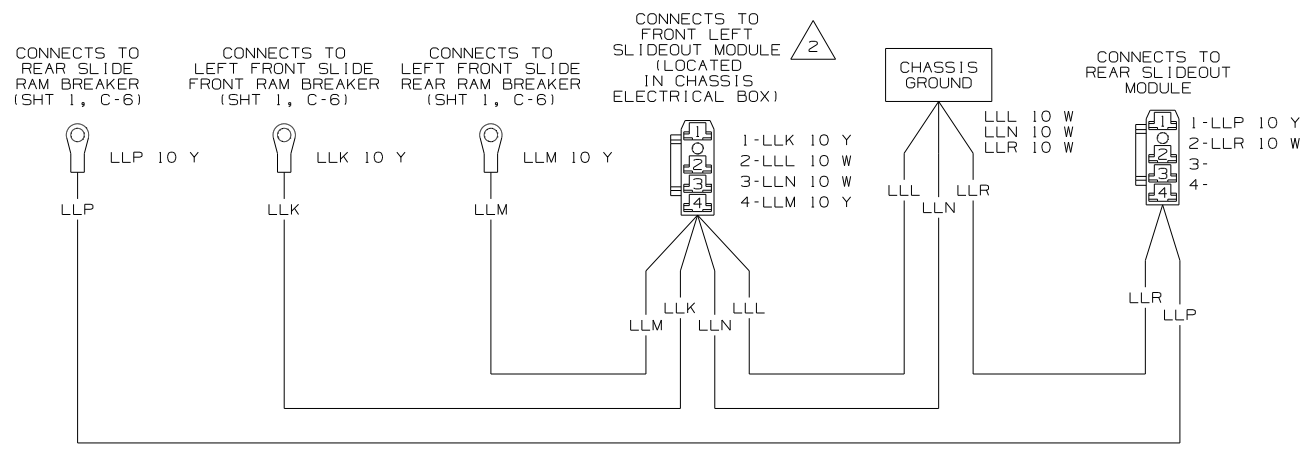

WIRING DIAGRAM-SLIDEOUT POWER
(WIRE ASM 149552-09 REV-N)

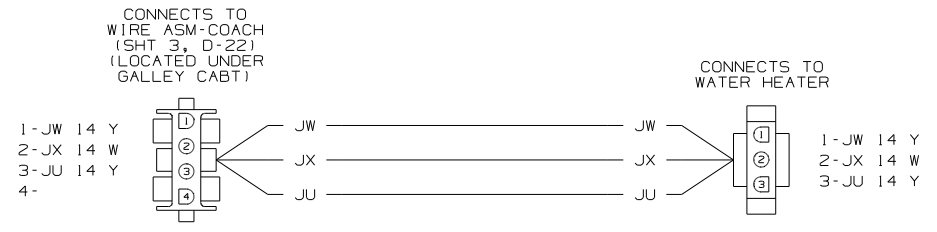

WIRING DIAGRAM-JUMPER,WTR HTR
(WIRE ASM 142263 REV-A)

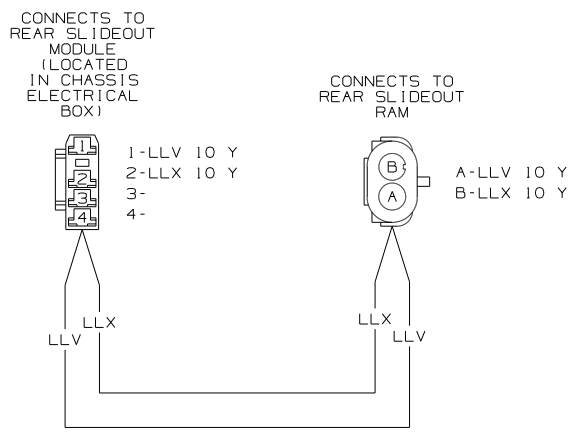

WIRING DIAGRAM-SLIDEOUT RAMS,REAR
(WIRE ASM 149897-04 REV-F)

SEE MANUFACTURER'S DIAGRAM FOR ADDITIONAL INFORMATION.

- 1. SPLICES ARE THEORETICAL AND MAY DIFFER IN THE HARNESS.

NOTES:

FIRST USED	08 D29R	
TITLE	DO NOT SCALE DRAWING	
TITLE	WIRING DIAGRAM-BODY, 12V	
SHEET 7	PART NO	162633
	REV	