



DANGER

Danger of electrical shock, burns or death. Always remove all power sources before attempting any repair, service or diagnostic work. Power can be present from shore power, generator, inverter or battery. All power sources must be disabled and secured before performing any service.



CAUTION

If you lack the skills, tools or equipment to perform diagnostic or repair work leave such work to an authorized Winnebago Industries dealer or other qualified shop.

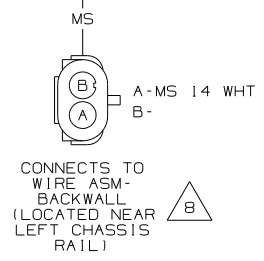
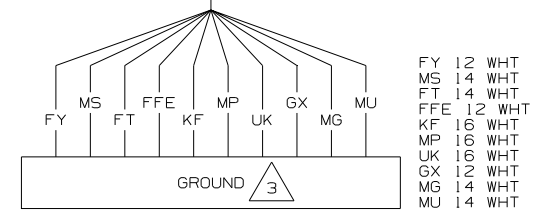
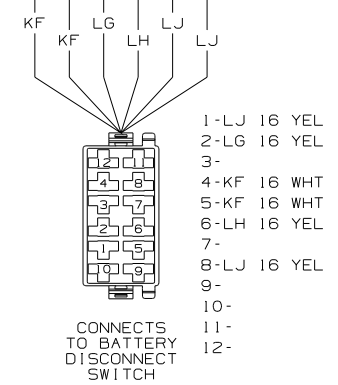
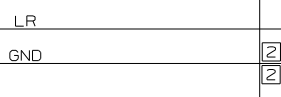
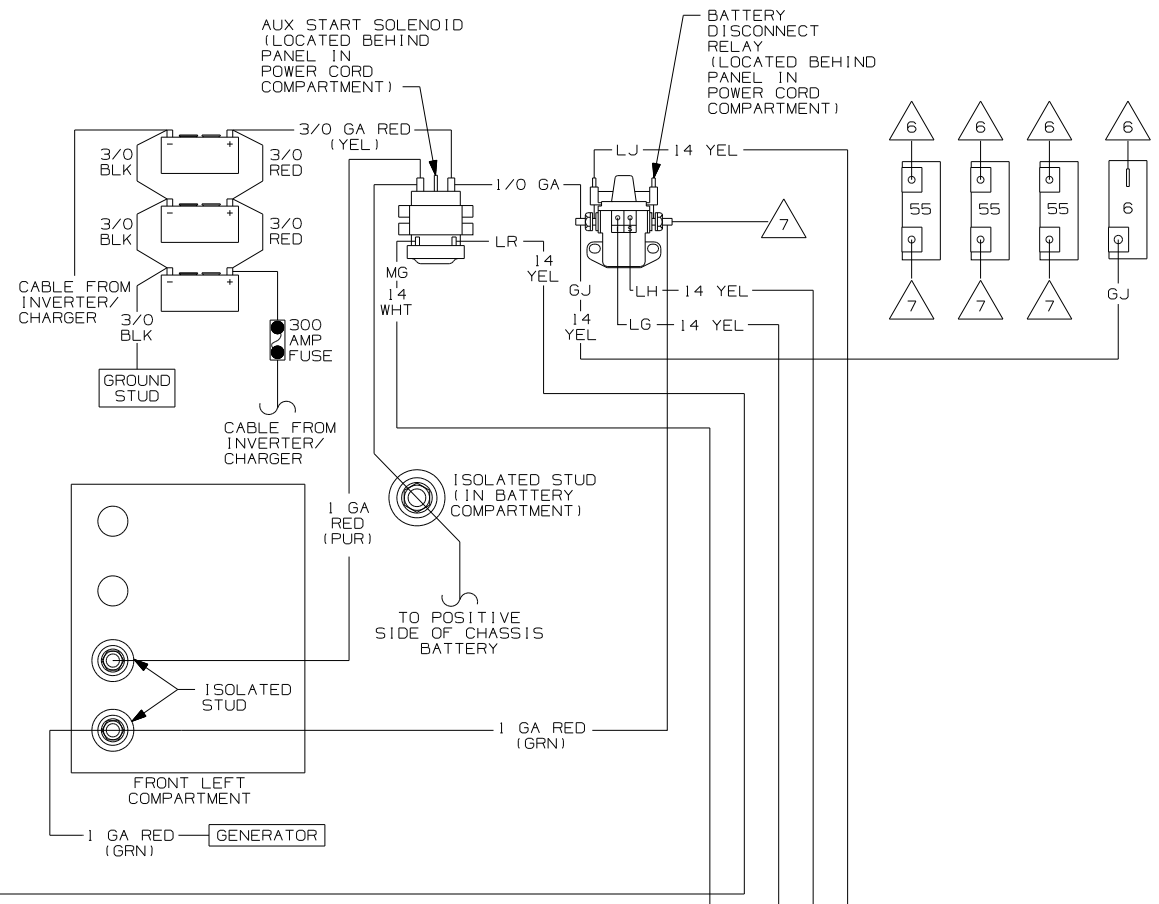
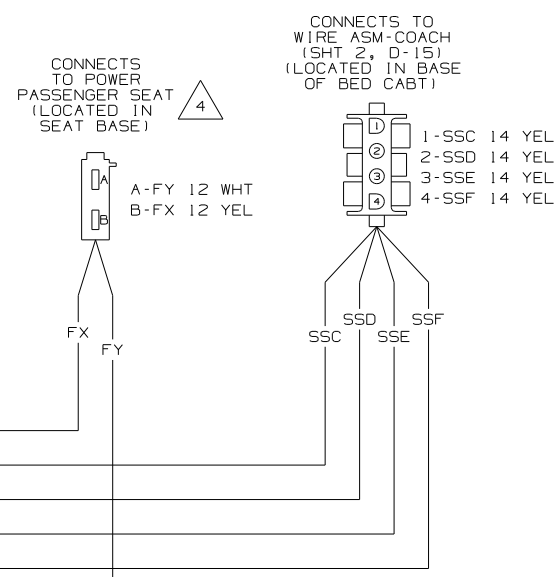

WIRING DIAGRAM-CHASSIS
(WIRE ASM 156178 REV-M)

WINNEBAGO		COPYRIGHT 2006 WINNEBAGO INDUSTRIES, INC.	
DFTR	ORIG. DATE	ALL DIMENSIONS ARE IN MILLIMETERS	
CHNR		FIRST USED	
P.E.		07 S40KD	
M.E.		UNSPECIFIED TOLERANCES ARE:	
DSNR		MATERIAL:	
		WHOLE DIM (X)	:
		ONE-PLACE (X,X)	:
		TWO-PLACE (X,XX)	:
		ANGLE	:
THIRD ANGLE PROJECTION			
DO NOT SCALE DRAWING			
TITLE: WIRING DIAGRAM-BODY, 12V			
SHEET 1 of 8	PART NO	156181	REV
REF:	1	12/19/2006	

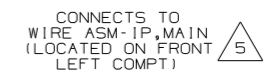
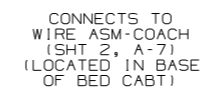
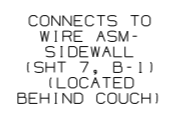
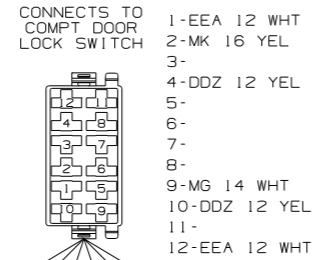
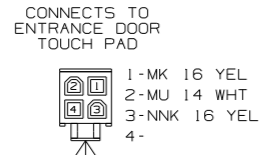
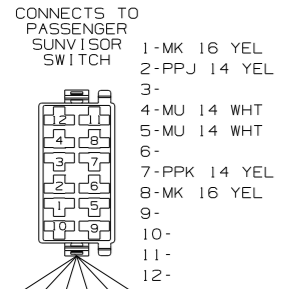

- A1-DDT 12 YEL
- A2-DDU 12 WHT
- A3-DDV 12 YEL
- B1-CCZ 16 YEL
- B2-
- B3-
- B4-
- C1-DDZ 12 YEL
- C2-EEA 12 WHT
- D1-PPS 14 YEL

- D2-PPT 14 YEL
- D3-PPU 14 YEL
- D4-PPV 14 YEL
- E1-NNK 16 YEL
- E2-KKL 16 YEL
- F1-
- F2-
- G1-
- G2-SSC 14 YEL
- G3-SSD 14 YEL
- G4-SSE 14 YEL
- H1-LP 16 YEL
- H2-SSF 14 YEL
- H3-
- J1-SSA 14 YEL
- J2-SSB 14 YEL
- J3-
- J4-KKN 16 YEL
- K1-DDW 12 WHT
- K2-HHD 12 YEL
- K3-FX 12 YEL

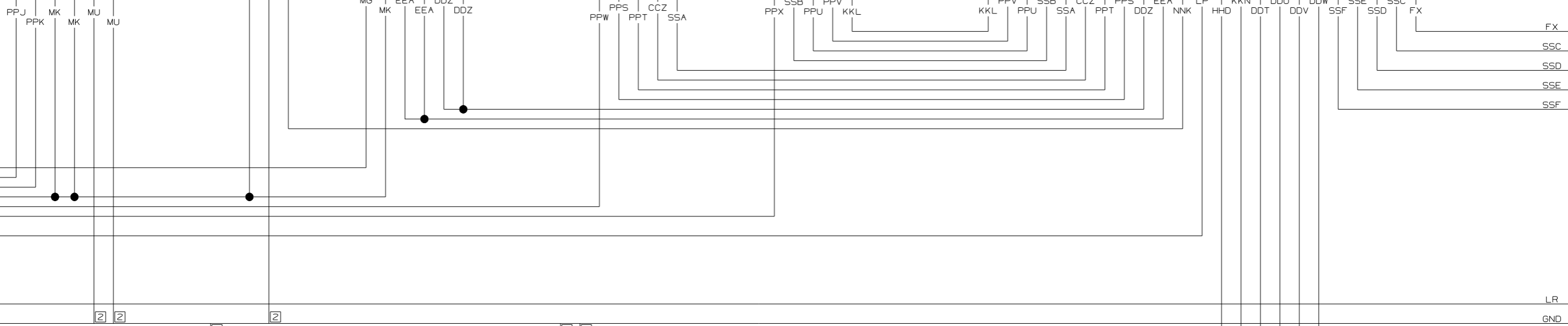

- KKN
- HU
- DDT
- DDU
- DDV
- DDW
- KA
- JJZ

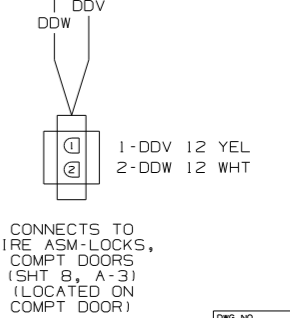
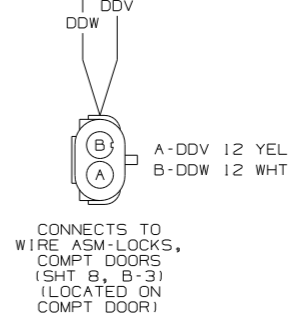
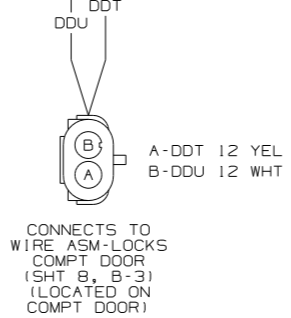
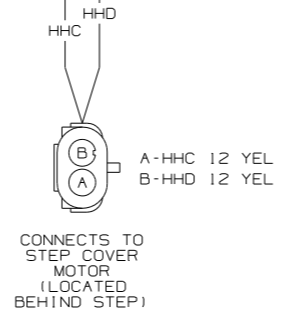
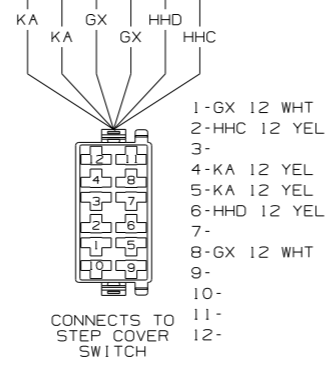
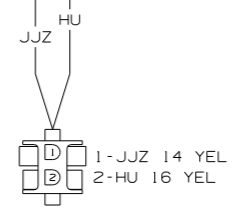
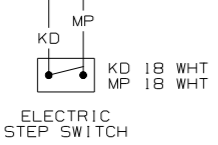
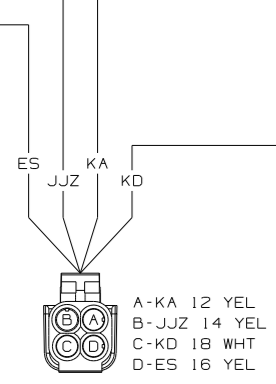

CONNECTS TO WIRE ASM-IP,MAIN (LOCATED ON FRONT LEFT COMPT) 5

- A1-
- A2-
- A3-FS 14 YEL
- B1-BBM 16 YEL
- B2-BBN 16 YEL
- B3-CCY 16 YEL
- B4-KKK 16 YEL
- C1-DDA 16 YEL
- C2-PPJ 14 YEL
- D1-LL 16 WHT

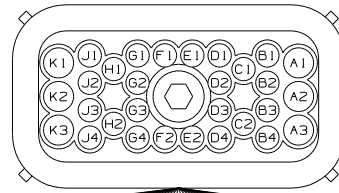

- D2-LM 16 WHT
- D3-LN 16 WHT
- D4-HU 16 YEL
- E1-MM 14 YEL
- E2-WC 16 YEL
- F1-MK 16 YEL
- F2-LR 14 YEL
- G1-PPW 14 YEL
- G2-PPX 14 YEL
- G3-
- G4-
- H1-PPK 14 YEL
- H2-PX 16 YEL
- J1-PJ 16 YEL
- J2-JJZ 14 YEL
- J3-ER 16 YEL
- J4-PY 16 YEL
- K1-FFD 12 YEL
- K2-KA 12 YEL
- K3-

CONNECTS TO LOUNGE LAMP SWITCH

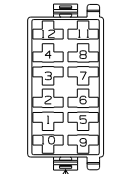

- 1-FFW 14 YEL
- 2-PL 14 YEL
- 3-
- 4-FFX 14 YEL
- 5-
- 6-
- 7-
- 8-
- 9-
- 10-
- 11-
- 12-

CONNECTS TO WIRE ASM-SOFA (SHT 8, C-4 OR SHT 8, D-6) (LOCATED BEHIND SOFA)



- 1-EEC 12 YEL
- 2-EED 12 WHT

CONNECTS TO WIRE ASM-COACH (SHT 2, A-24) (LOCATED IN BASE OF BED CABT)

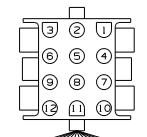

- 1-BBM 16 YEL
- 2-BBN 16 YEL
- 3-DDA 16 YEL
- 4-CCY 16 YEL
- 5-KKK 16 YEL
- 6-PL 14 YEL
- 7-FFW 14 YEL
- 8-FFX 14 YEL
- 9-EEC 12 YEL
- 10-EED 12 WHT
- 11-JG 14 YEL
- 12-JN 14 WHT

CONNECTS TO DOOR LOCK SWITCH

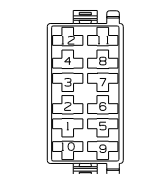

- 1-PY 16 YEL
- 2-MK 16 YEL
- 3-
- 4-PX 16 YEL
- 5-
- 6-
- 7-
- 8-
- 9-MG 14 WHT
- 10-PX 16 YEL
- 11-
- 12-PY 16 YEL

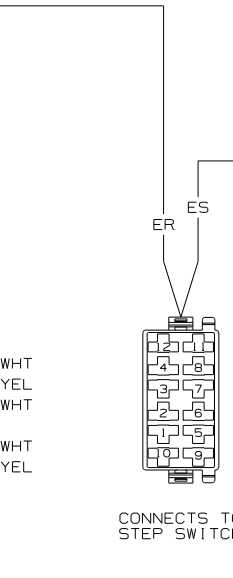
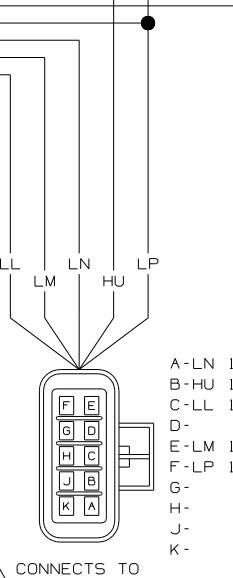
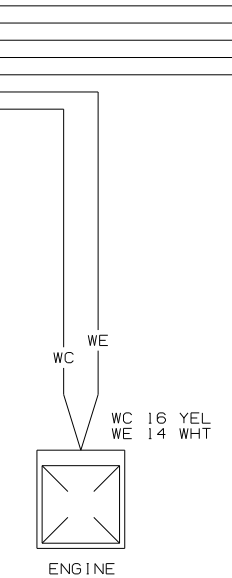
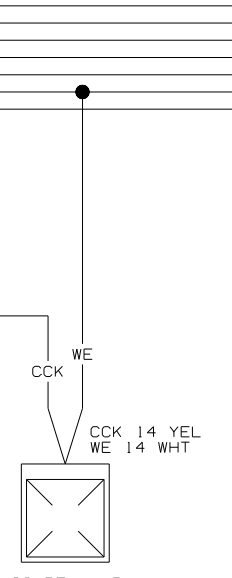
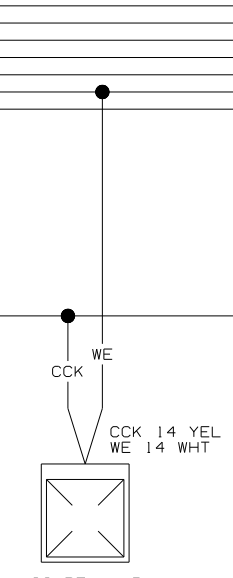
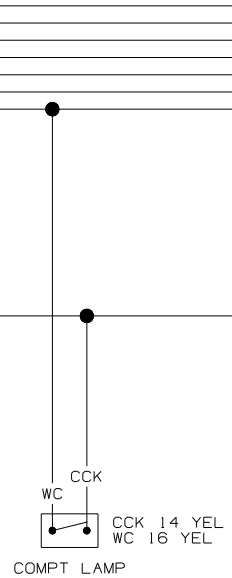
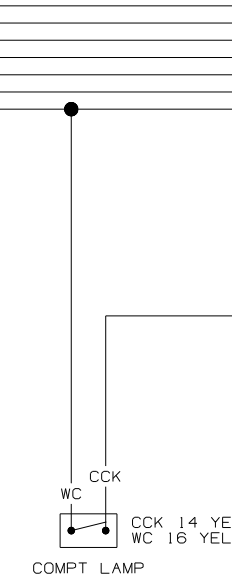
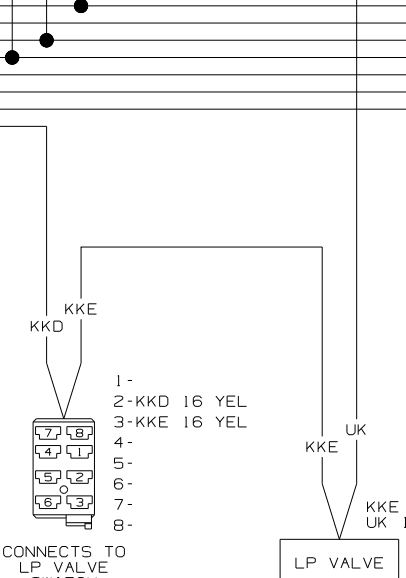
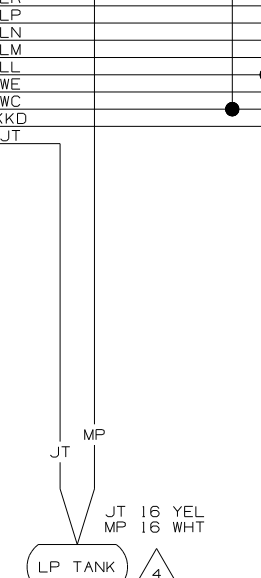
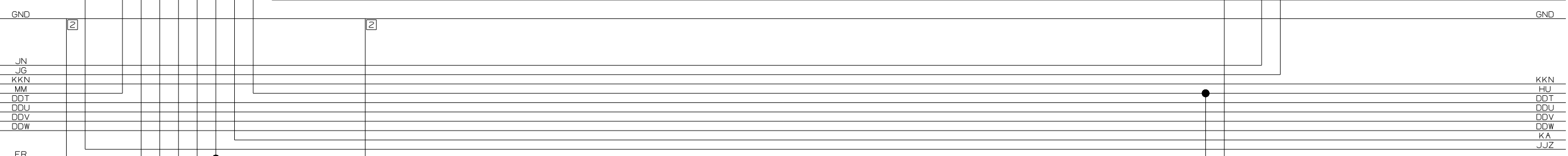
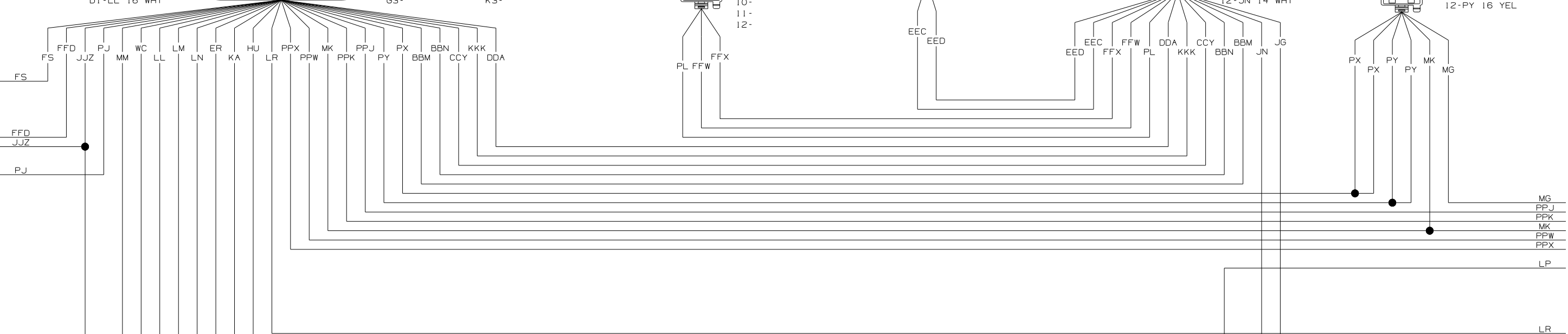

- 1-KKE
- 2-KKD 16 YEL
- 3-KKE 16 YEL
- 4-
- 5-
- 6-
- 7-
- 8-

- A-LN 16 WHT
- B-HU 16 YEL
- C-LL 16 WHT
- D-
- E-LM 16 WHT
- F-LP 16 YEL
- G-
- H-
- J-
- K-

- 1-
- 2-ER 16 YEL
- 3-
- 4-ES 16 YEL
- 5-
- 6-
- 7-
- 8-
- 9-
- 10-
- 11-
- 12-

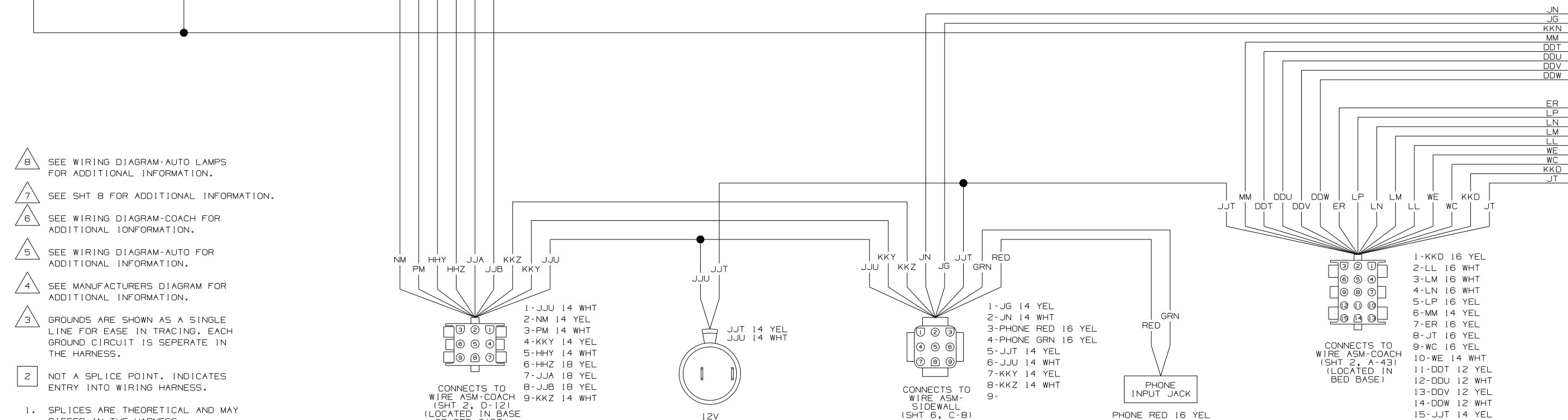
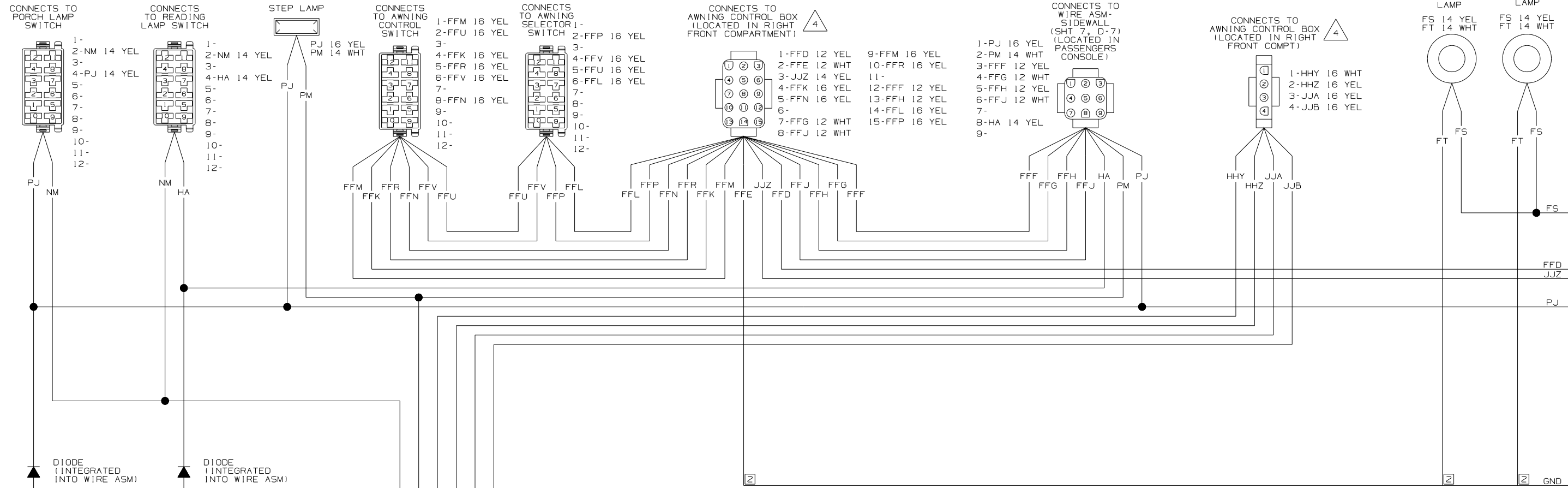

- 8 SEE WIRING DIAGRAM-AUTO LAMPS FOR ADDITIONAL INFORMATION.
 - 7 SEE SHT 8 FOR ADDITIONAL INFORMATION.
 - 6 SEE WIRING DIAGRAM-COACH FOR ADDITIONAL INFORMATION.
 - 5 SEE WIRING DIAGRAM-AUTO FOR ADDITIONAL INFORMATION.
 - 4 SEE MANUFACTURERS DIAGRAM FOR ADDITIONAL INFORMATION.
 - 3 GROUNDS ARE SHOWN AS A SINGLE LINE FOR EASE IN TRACING. EACH GROUND CIRCUIT IS SEPERATE IN THE HARNESS.
 - 2 NOT A SPLICE POINT. INDICATES ENTRY INTO WIRING HARNESS.
- NOTES:
1. SPLICES ARE THEORETICAL AND MAY DIFFER IN THE HARNESS.

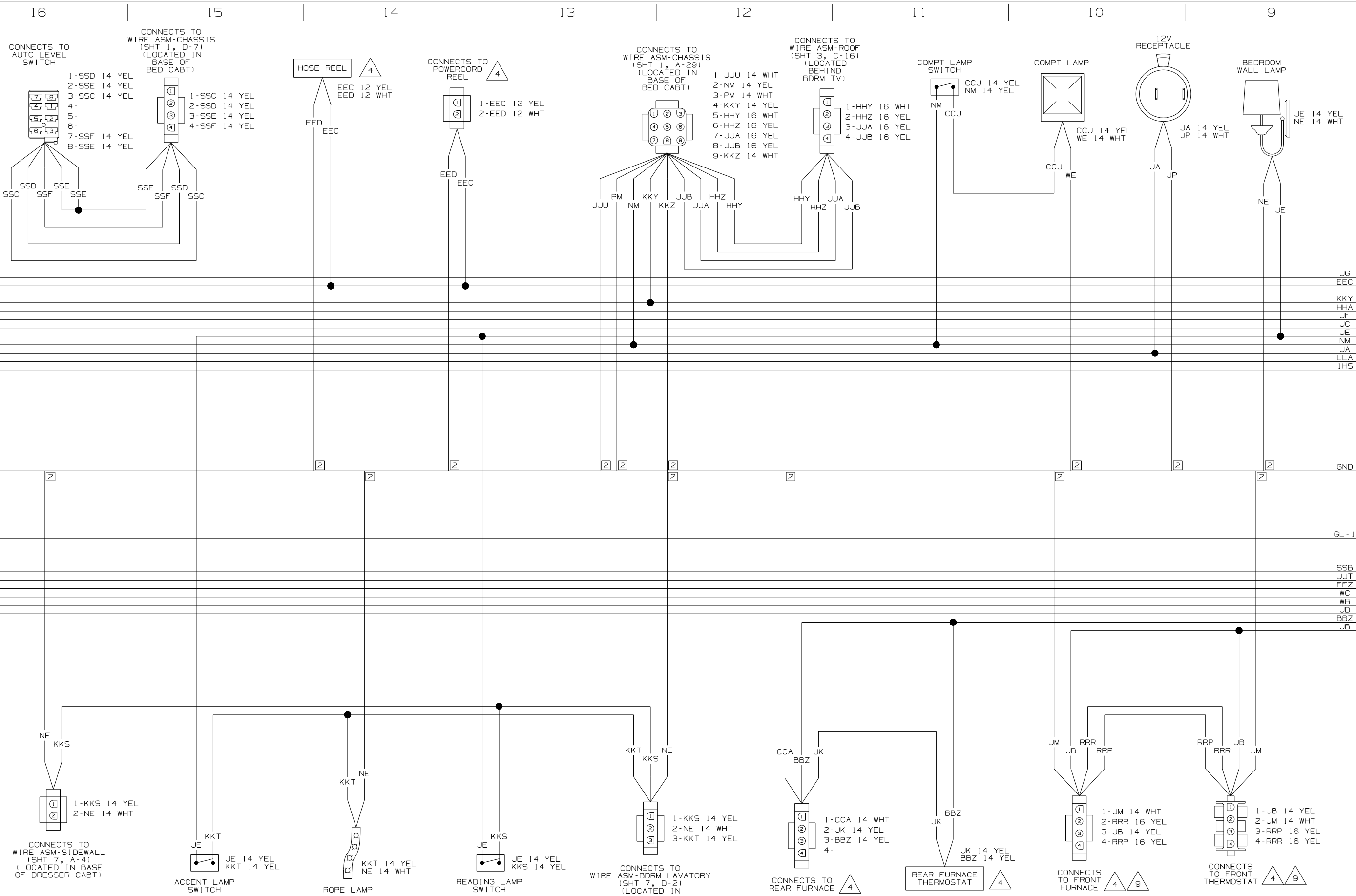

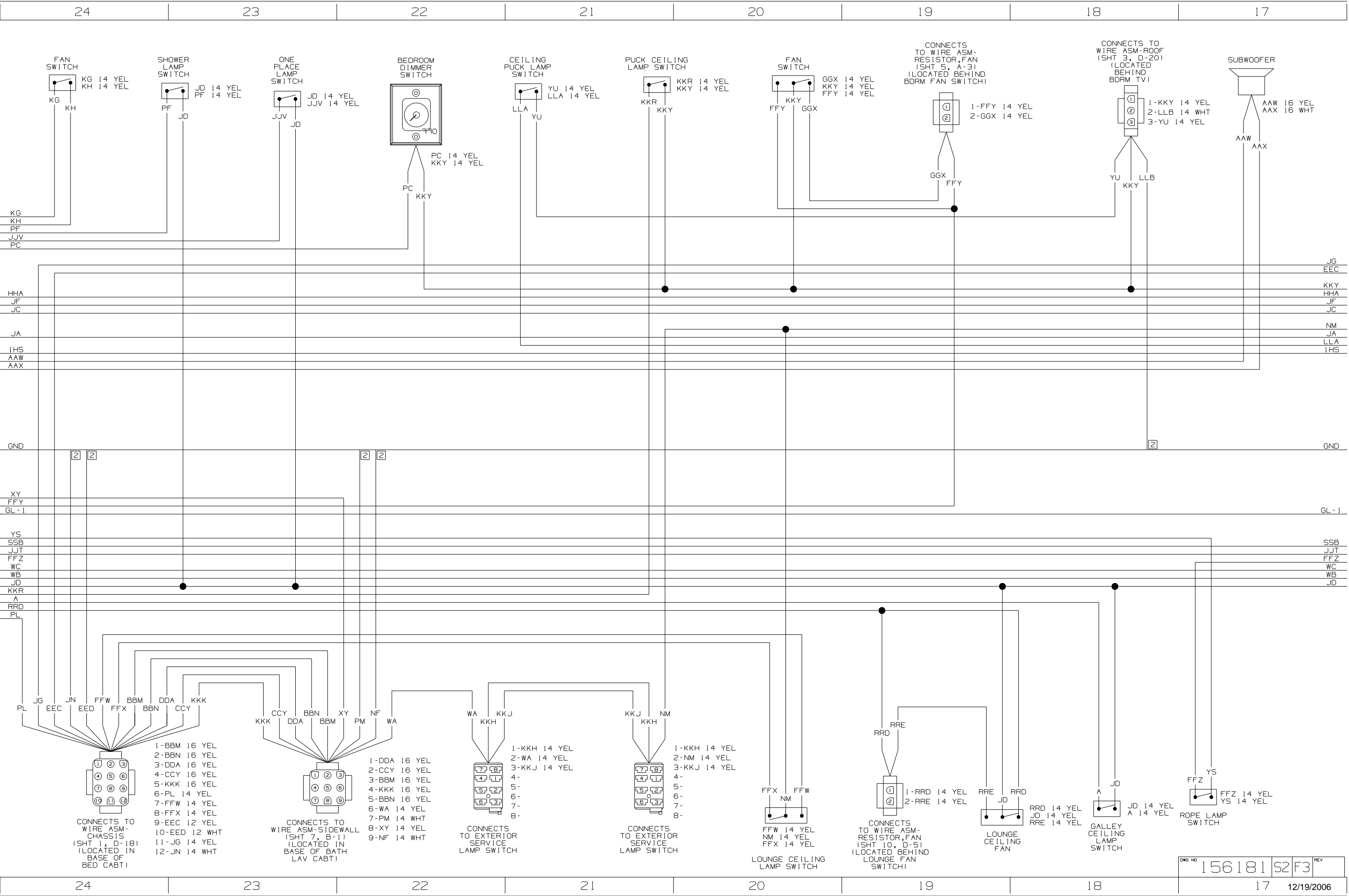

24

23

22

21

20

19

18

17

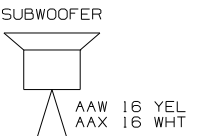
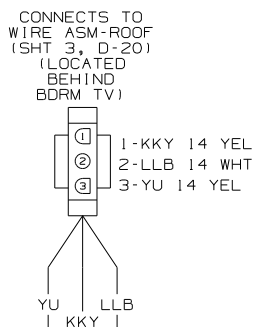
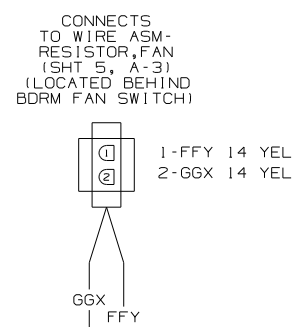
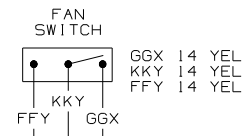
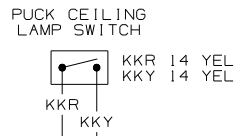
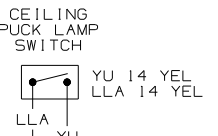
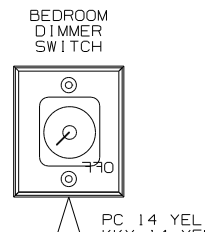
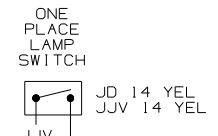
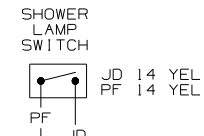
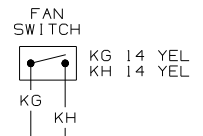

24

23

22

21

20

19

18

17

12/19/2006

DWG NO 156181 S2 F3 REV

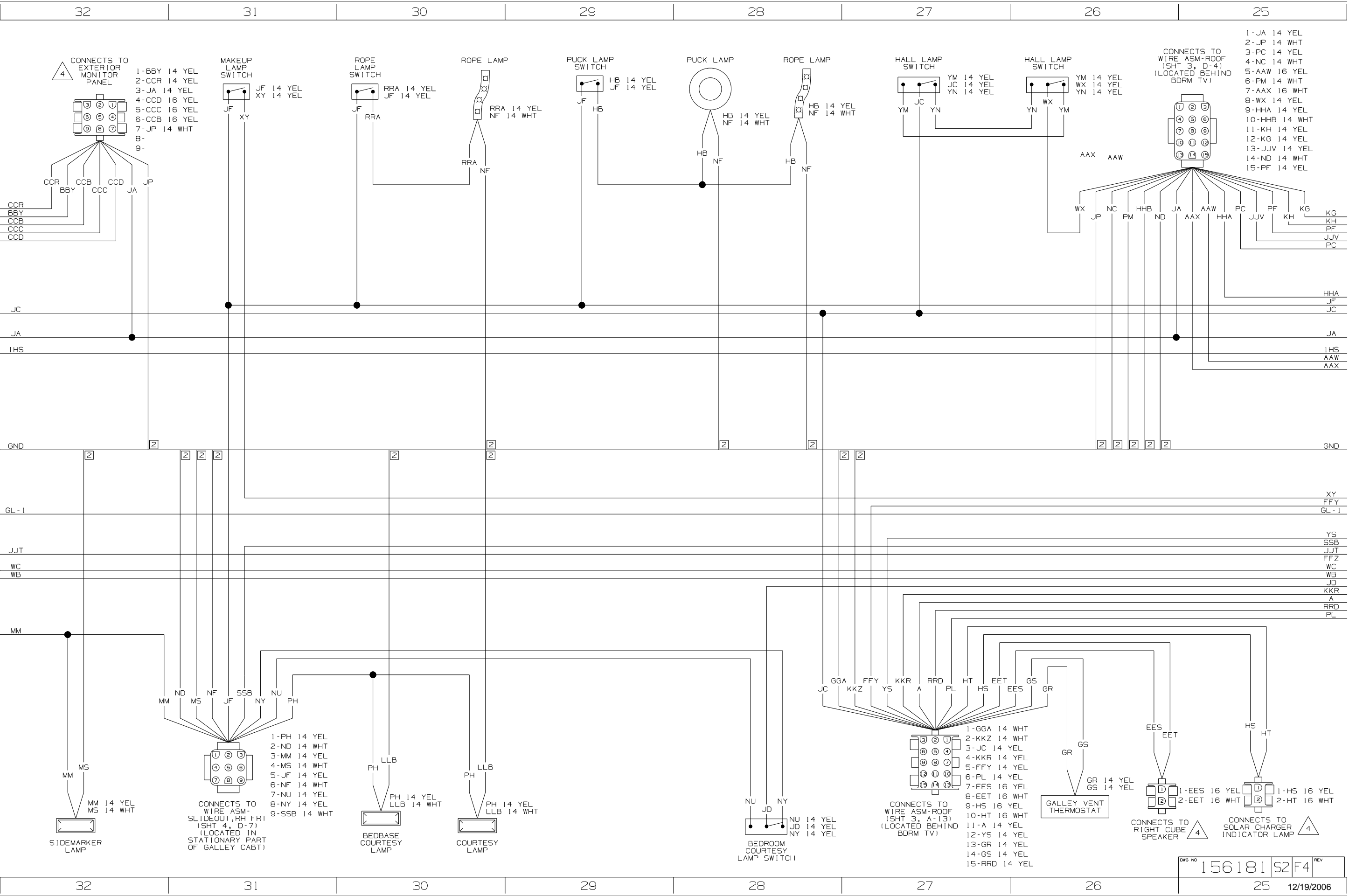

- 1-JA 14 YEL
- 2-ER 16 YEL
- 3-GL 16 WHT
- 4-XH 16 YEL
- 5-XJ 16 YEL
- 6-XK 16 YEL
- 7-AG 12 YEL
- 8-JS 12 YEL
- 9-AF 12 YEL
- 10-
- 11-
- 12-JT 16 YEL
- 13-JW 14 YEL
- 14-
- 15-JU 14 YEL

CONNECTS TO MONITOR PANEL 4

CONNECTS TO WATER HEATER 4

WATER HEATER SWITCH
 JA 14 YEL
 HHJ 14 YEL
 JP 14 WHT

WATER PUMP
 JS 12 YEL
 JY 12 WHT

CONNECTS TO WATER PUMP SWITCH
 1-AG 12 YEL
 2-JA 12 YEL
 3-AF 12 YEL
 4-
 5-
 6-
 7-JS 12 YEL
 8-JP 14 WHT

CONNECTS TO WIRE ASM-AUX HOLDING 8

CONNECTS TO WIRE ASM-MAIN HOLDING 8

CONNECTS TO WIRE ASM-WATER TANK 8

CONNECTS TO MONITOR PANEL SWITCH

7

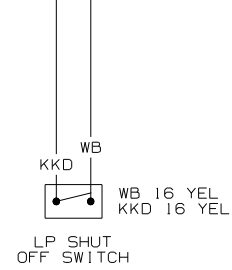
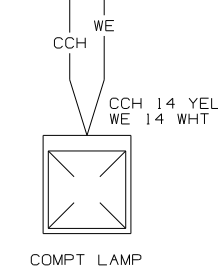
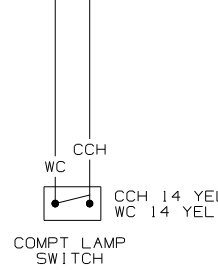
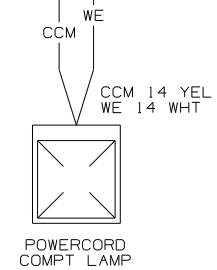
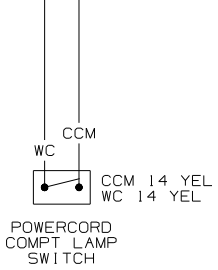
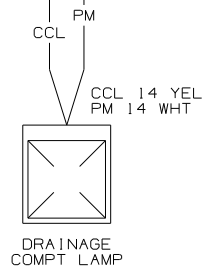
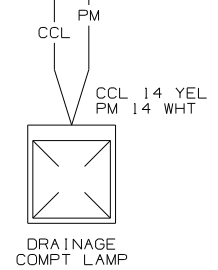
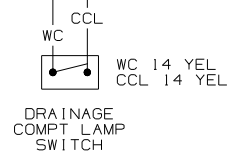
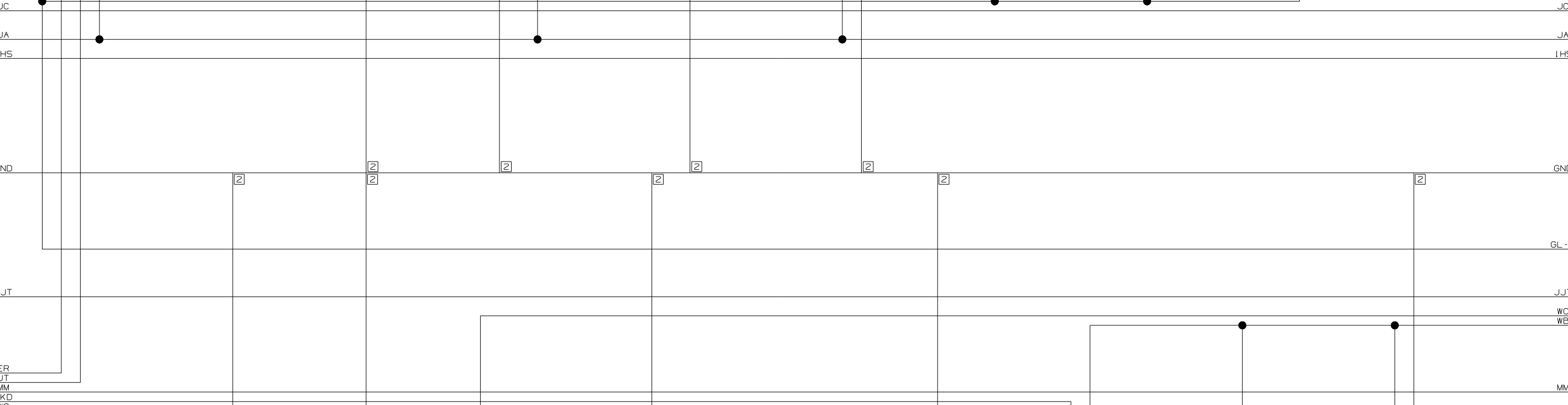

CONNECTS TO INVERTER REMOTE PANEL 4

CONNECTS TO LP DETECTOR 4

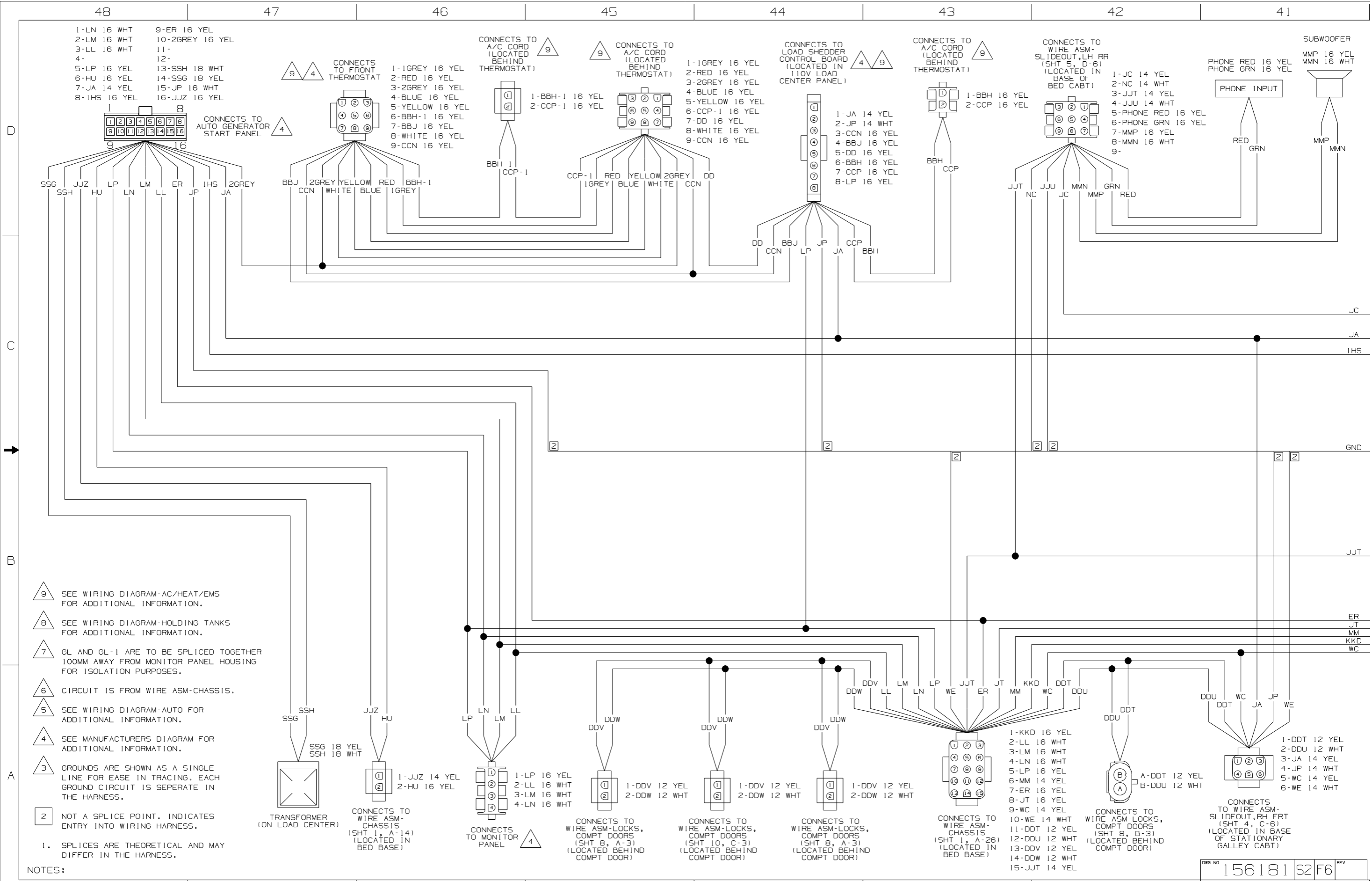

- 9 SEE WIRING DIAGRAM-AC/HEAT/EMS FOR ADDITIONAL INFORMATION.
- 8 SEE WIRING DIAGRAM-HOLDING TANKS FOR ADDITIONAL INFORMATION.
- 7 GL AND GL-1 ARE TO BE SPLICED TOGETHER 100MM AWAY FROM MONITOR PANEL HOUSING FOR ISOLATION PURPOSES.
- 6 CIRCUIT IS FROM WIRE ASM-CHASSIS.
- 5 SEE WIRING DIAGRAM-AUTO FOR ADDITIONAL INFORMATION.
- 4 SEE MANUFACTURERS DIAGRAM FOR ADDITIONAL INFORMATION.
- 3 GROUNDS ARE SHOWN AS A SINGLE LINE FOR EASE IN TRACING. EACH GROUND CIRCUIT IS SEPERATE IN THE HARNESS.
- 2 NOT A SPLICE POINT. INDICATES ENTRY INTO WIRING HARNESS.
1. SPLICES ARE THEORETICAL AND MAY DIFFER IN THE HARNESS.

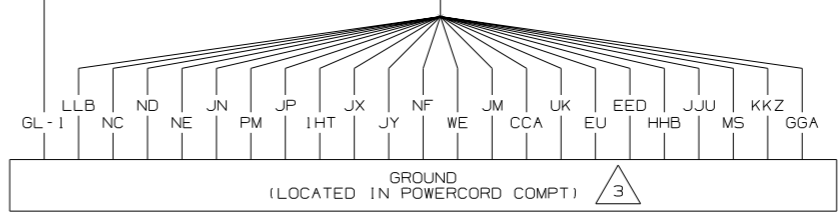
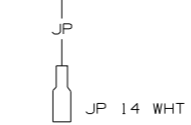
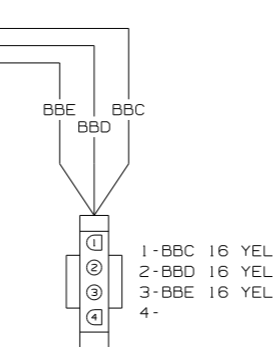
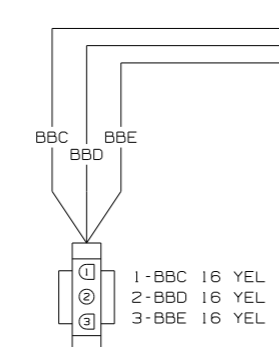
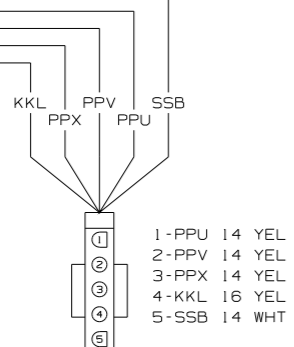
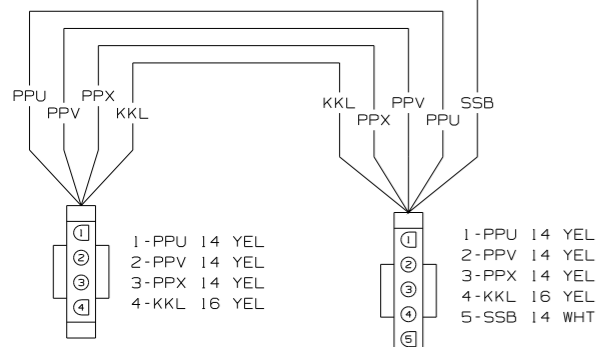
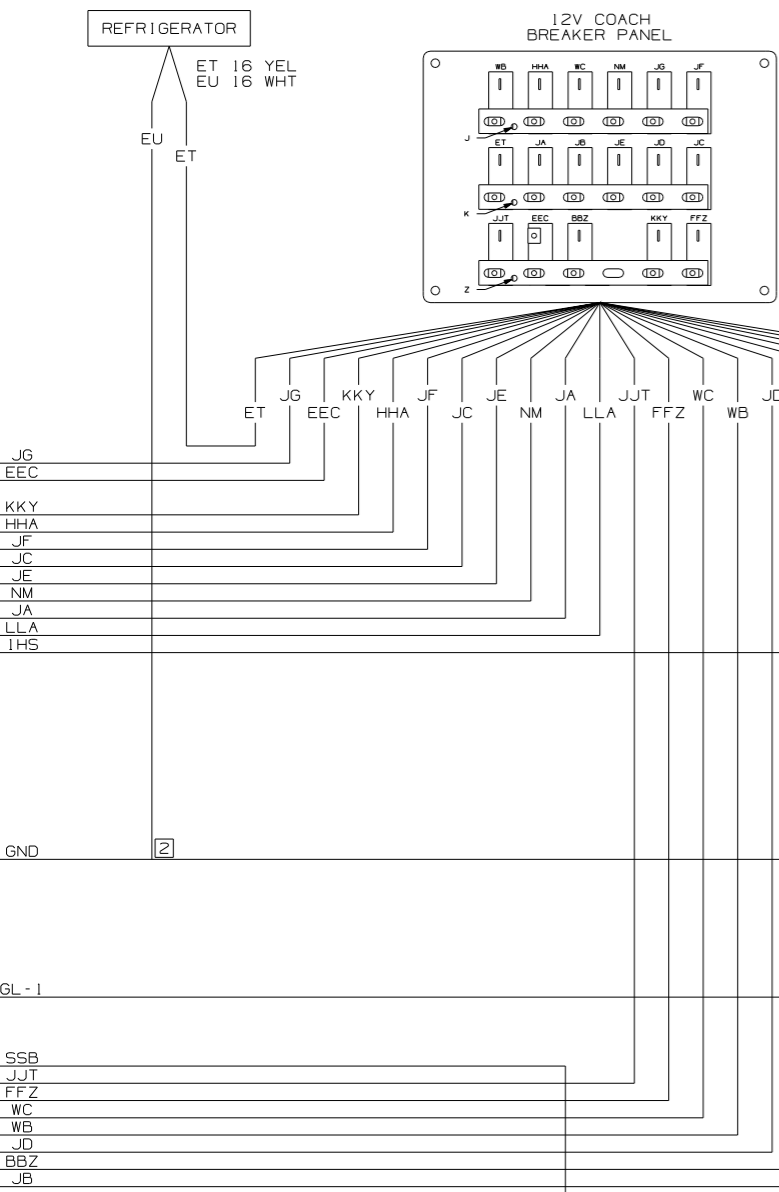
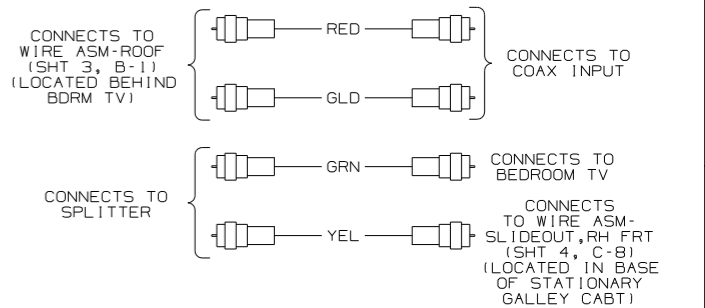
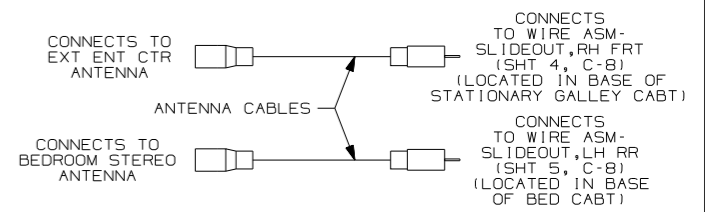
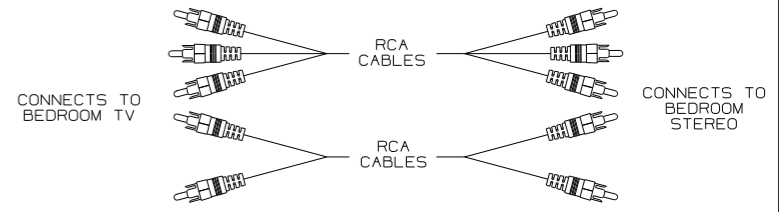
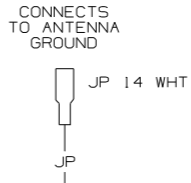
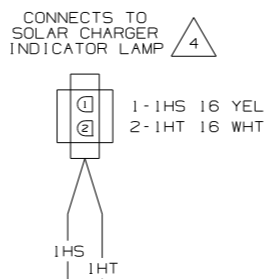
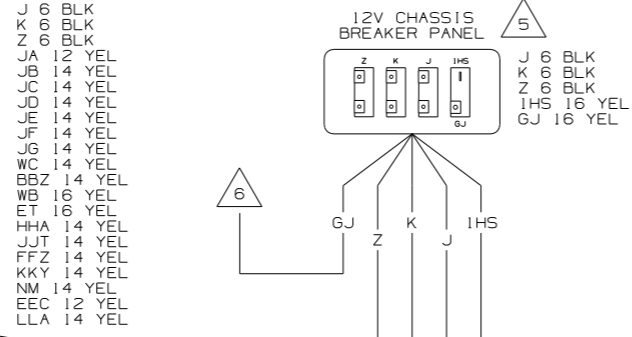
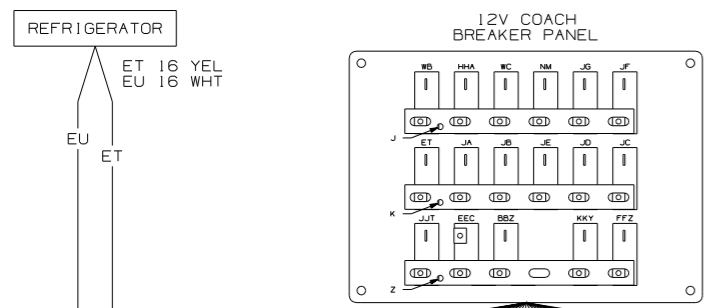

- NC 14 WHT
- ND 14 WHT
- NE 14 WHT
- JN 14 WHT
- PM 14 WHT
- JP 14 WHT
- IHT 16 WHT
- GL-1 14 WHT
- JX 14 WHT
- JY 12 WHT
- NF 14 WHT
- WE 14 WHT
- JM 14 WHT
- CCA 14 WHT
- UK 16 WHT
- EU 16 WHT
- EED 12 WHT
- HHB 14 WHT
- JJU 14 WHT
- MS 14 WHT
- KKZ 14 WHT
- GGA 14 WHT
- LLB 14 WHT

WIRING DIAGRAM-COACH (WIRE ASM 156179 REV-K)

FIRST USED	07 S40KD	
TITLE	DO NOT SCALE DRAWING	
	WIRING DIAGRAM-BODY, 12V	
SHEET 2	PART NO	156181

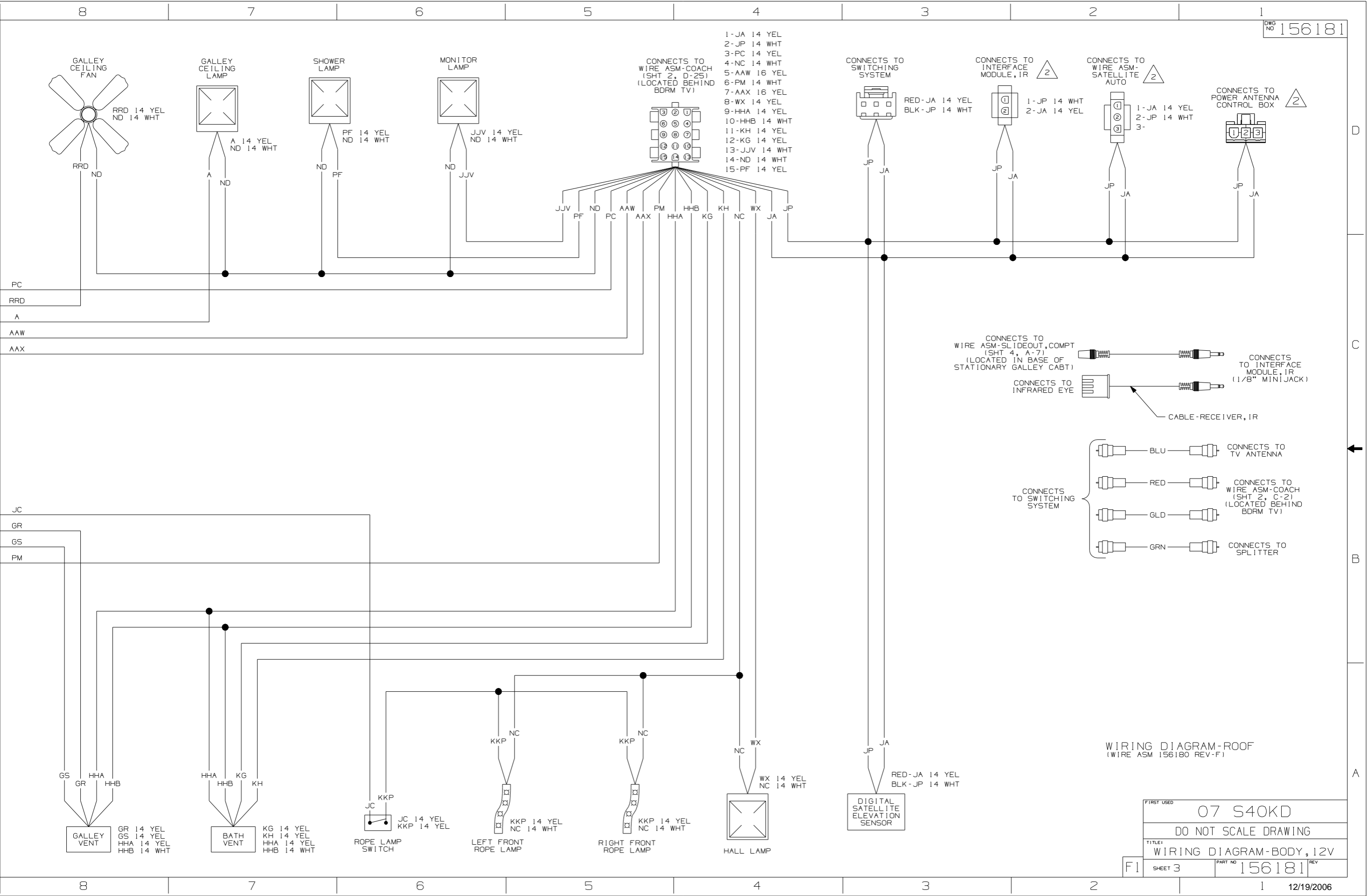

WIRING DIAGRAM-ROOF (WIRE ASM 156180 REV-F)

FIRST USED	07 S40KD	
DO NOT SCALE DRAWING		
TITLE	WIRING DIAGRAM-BODY, 12V	
SHEET 3	PART NO	156181
F1	REV	12/19/2006

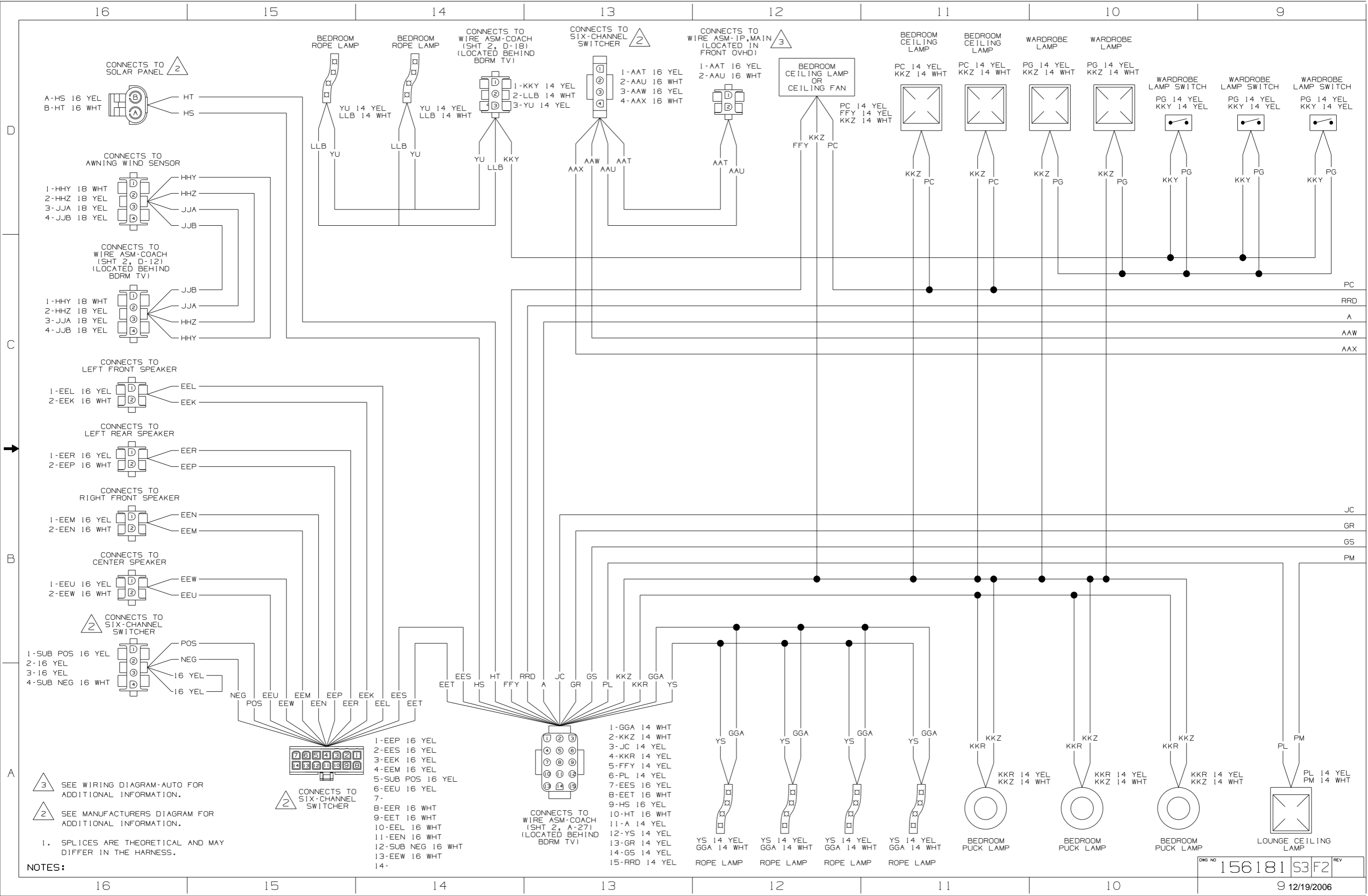

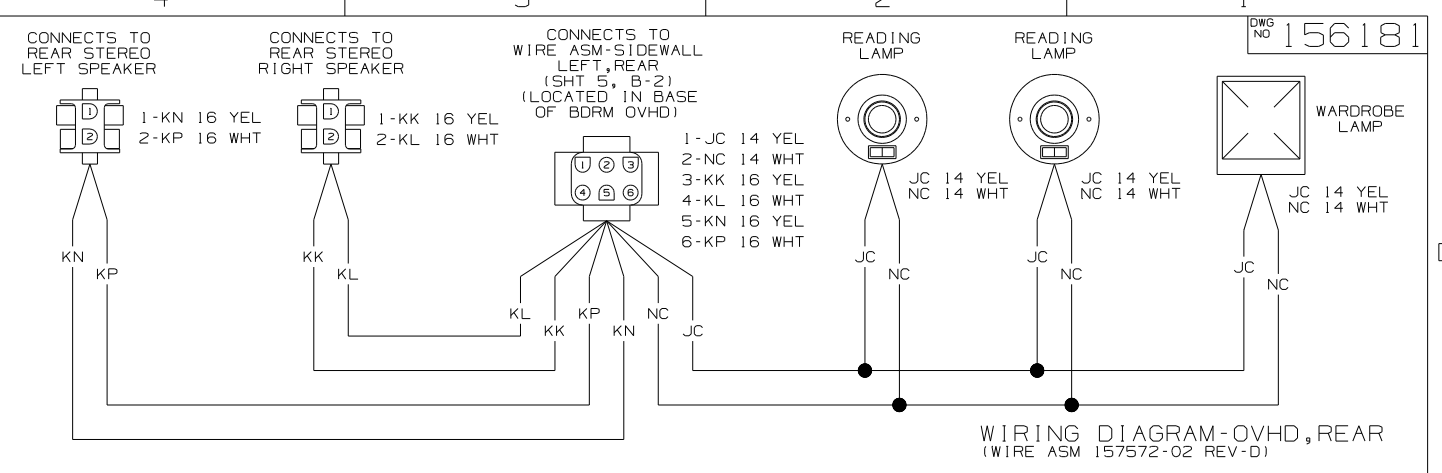
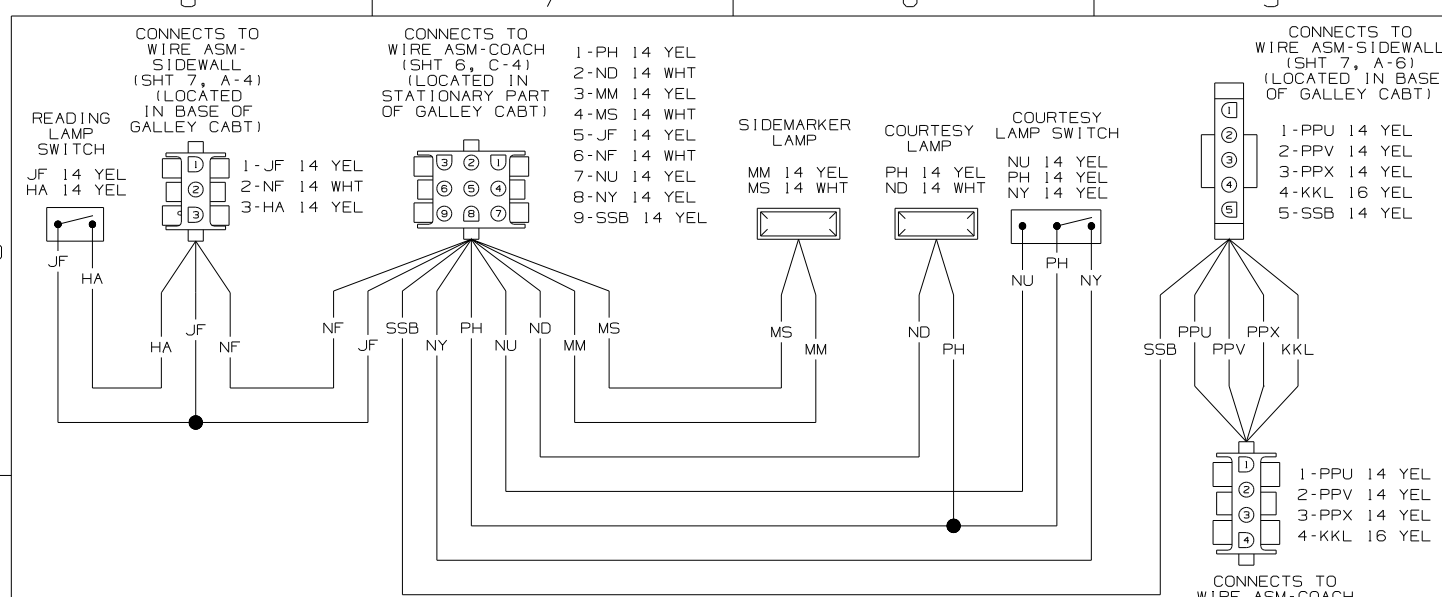

WIRING DIAGRAM-OVHD, REAR (WIRE ASM 157572-02 REV-D)

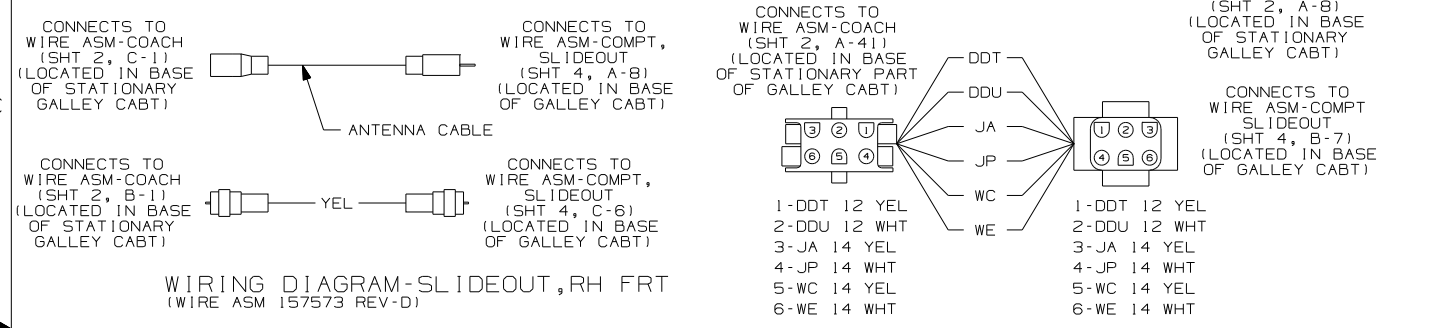

WIRING DIAGRAM-SLIDEOUT, RH FRT (WIRE ASM 157573 REV-D)

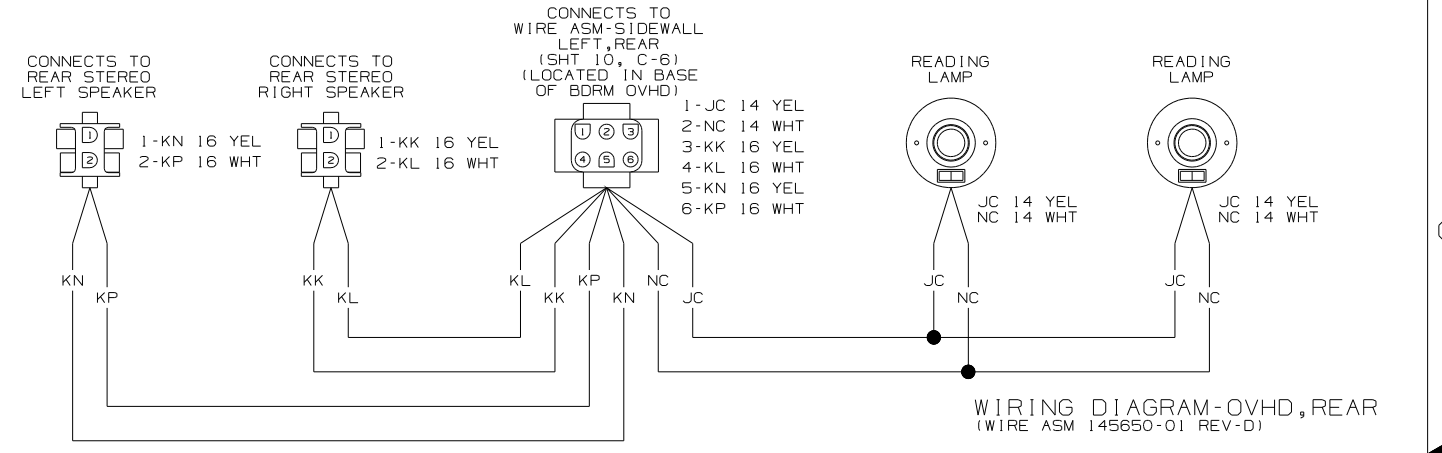

WIRING DIAGRAM-OVHD, REAR (WIRE ASM 145650-01 REV-D)

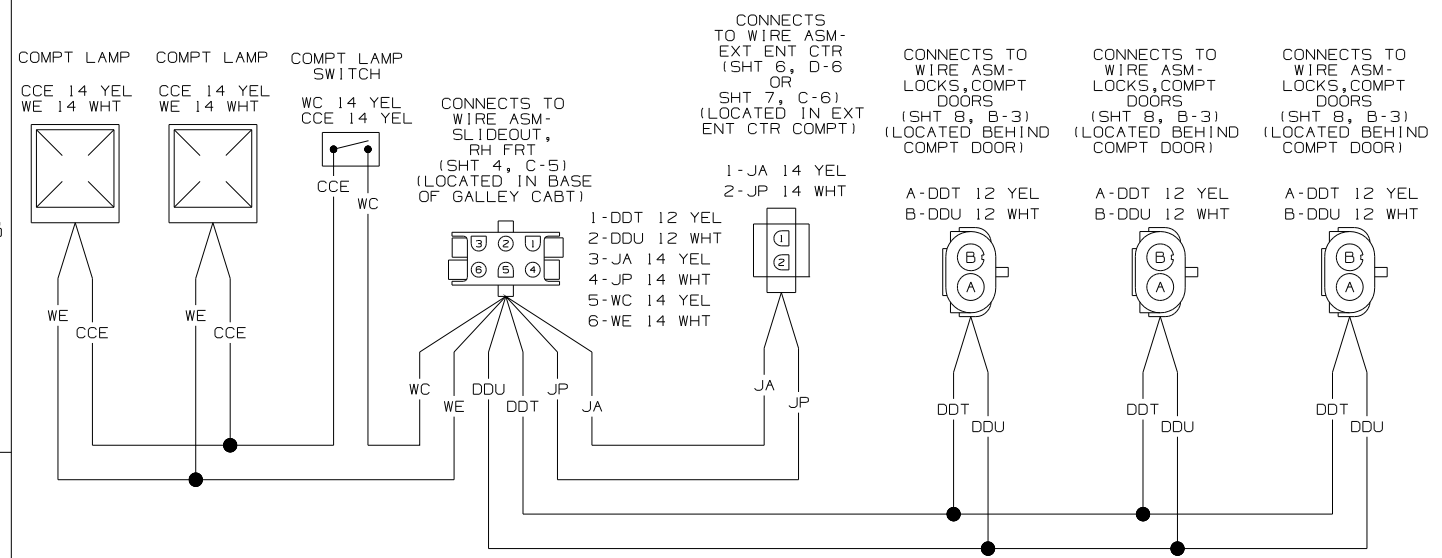

WIRING DIAGRAM-COMPT SLIDEOUT (WIRE ASM 156594 REV-E)

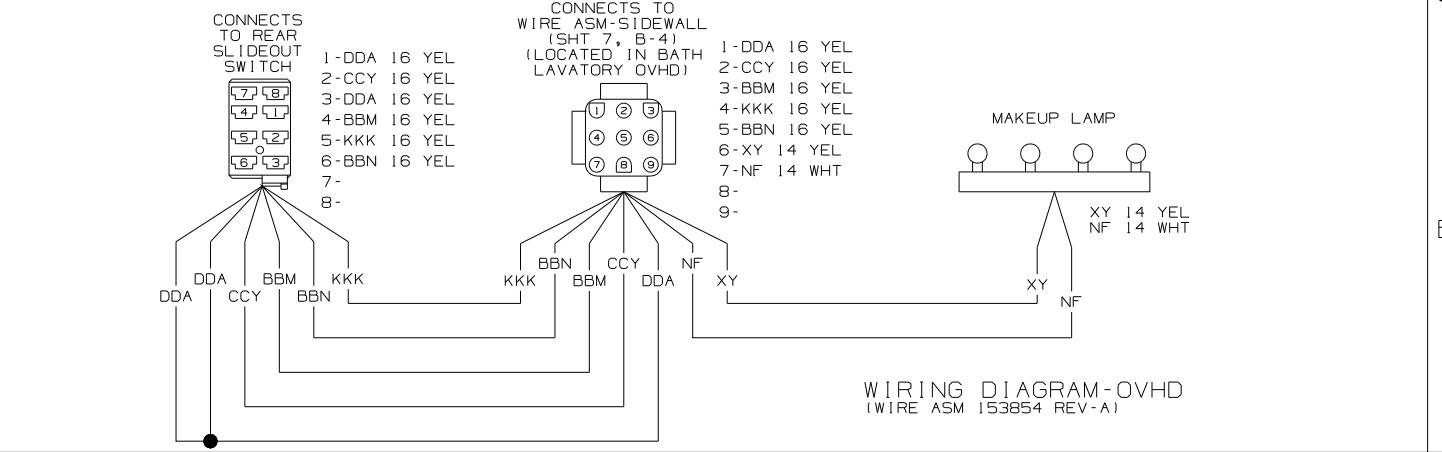

WIRING DIAGRAM-OVHD (WIRE ASM 153854 REV-A)

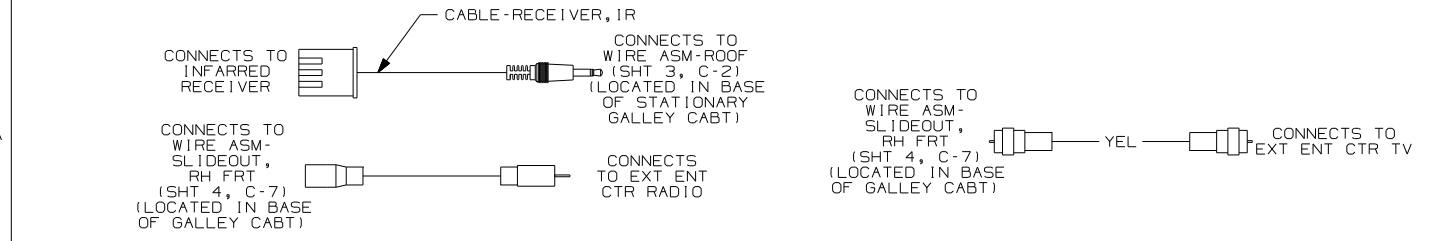

WIRING DIAGRAM-SIDEWALL (WIRE ASM 137479-02 REV-A)

NOTES:
 1. SPLICES ARE THEORETICAL AND MAY DIFFER IN THE HARNESS.

FIRST USED	07 S40KD		
TITLE	DO NOT SCALE DRAWING		
TITLE	WIRING DIAGRAM-BODY, 12V		
SHEET 4	PART NO	156181	REV

12V RECEPTACLE

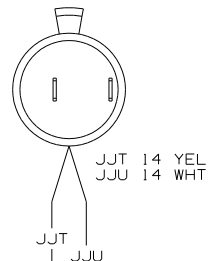

PHONE JACK

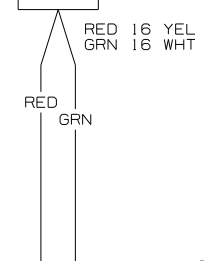

CONNECTS TO WIRE ASM-COACH (SHT 2, D-42) (LOCATED IN BASE OF BED CABT)

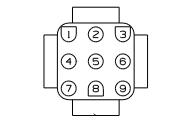

- 1-JC 14 YEL
- 2-NC 14 WHT
- 3-JJT 14 YEL
- 4-JJU 14 WHT
- 5-RED 16 YEL
- 6-GRN 16 WHT
- 7-MMP 16 YEL
- 8-MMN 16 WHT
- 9-

CONNECTS TO CROSSOVER COIL (Z)

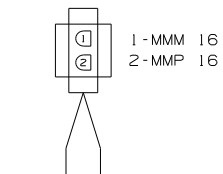

- 1-MMM 16 YEL
- 2-MMP 16 YEL

CONNECTS TO CROSSOVER BOX (Z)

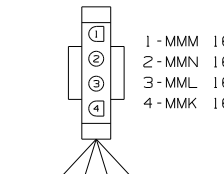

- 1-MMN 16 YEL
- 2-MMN 16 WHT
- 3-MML 16 WHT
- 4-MMK 16 YEL

CONNECTS TO REAR STEREO (Z)

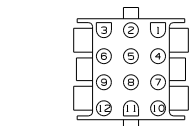

- 1-NC 14 WHT
- 2-JC 14 YEL
- 3-JC 14 YEL
- 4-
- 5-
- 6-MMK 16 YEL
- 7-MMN 16 WHT
- 8-
- 9-
- 10-
- 11-MML 16 WHT
- 12-MMM 16 YEL

CONNECTS TO WIRE ASM-SIDEWALL (SHT 5, B-3) (LOCATED IN BASE OF BED CABT)

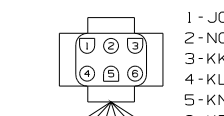

- 1-JC 14 YEL
- 2-NC 14 WHT
- 3-KK 16 YEL
- 4-KL 16 WHT
- 5-KN 16 YEL
- 6-KP 16 WHT

CONNECTS TO CROSSOVER BOX (Z)

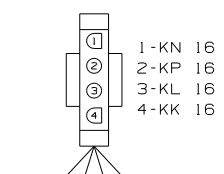

- 1-KN 16 YEL
- 2-KP 16 WHT
- 3-KL 16 WHT
- 4-KK 16 YEL

CONNECTS TO WIRE ASM-COACH (SHT 2, C-11) (LOCATED IN BASE OF BED CABT)

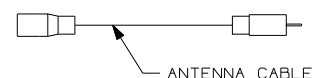

CONNECTS TO RADIO ANTENNA INPUT

WIRING DIAGRAM-SLIDEOUT, LH, RR (WIRE ASM 157571 REV-B)

CONNECTS TO WIRE ASM-SIDEWALL (SHT 2, C-5) (LOCATED IN CENTER OF LOUNGE OVHD)

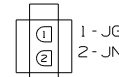

- 1-JG 14 YEL
- 2-JN 14 WHT

CONNECTS TO WIRE ASM-OVHD (SHT 7, A-5) (LOCATED IN CENTER OF LOUNGE OVHD)

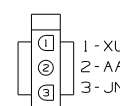

- 1-XU 14 YEL
- 2-AAB 14 YEL
- 3-JN 14 WHT

DINETTE OVHD LAMP SWITCH



PUCK LAMP SWITCH

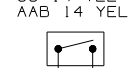

CONNECTS TO WIRE ASM-OVHD (SHT 7, C-4) (LOCATED IN CENTER OF LOUNGE OVHD)

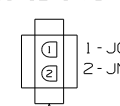

- 1-JG 14 YEL
- 2-JN 14 WHT

READING LAMP

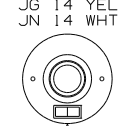

READING LAMP

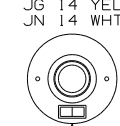

READING LAMP



CONNECTS TO WIRE ASM-SLIDEOUT, LH, RR (SHT 5, D-2) (LOCATED IN BASE OF BED CABT)

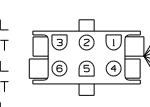

- 1-JC 14 YEL
- 2-NC 14 WHT
- 3-KK 16 YEL
- 4-KL 16 WHT
- 5-KN 16 YEL
- 6-KP 16 WHT

CONNECTS TO WIRE ASM-OVHD (SHT 4, C-3) OR (SHT 4, D-3) (LOCATED IN BASE OF BDRM OVHD)

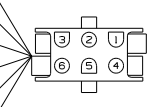

- 1-JC 14 YEL
- 2-NC 14 WHT
- 3-KK 16 YEL
- 4-KL 16 WHT
- 5-KN 16 YEL
- 6-KP 16 WHT

WIRING DIAGRAM-SIDEWALL (WIRE ASM 157556 REV-C)

CONNECTS TO WIRE ASM-COACH (SHT 2, A-19) AND (SHT 2, D-19) (LOCATED BEHIND FAN SWITCH)

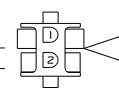

- 1-FFY 14 YEL
- 2-GGX 14 YEL



WIRING DIAGRAM-RESISTOR, FAN (WIRE ASM 140195 REV-A)

WIRING DIAGRAM-OVHD (WIRE ASM 153542-01 REV-F)

(Z) SEE MANUFACTURERS DIAGRAM FOR ADDITIONAL INFORMATION.

1. SPLICES ARE THEORETICAL AND MAY DIFFER IN THE HARNESS.

NOTES:

FIRST USED	07 S40KD	
TITLE	DO NOT SCALE DRAWING	
	WIRING DIAGRAM-BODY, 12V	
SHEET 5	PART NO	156181

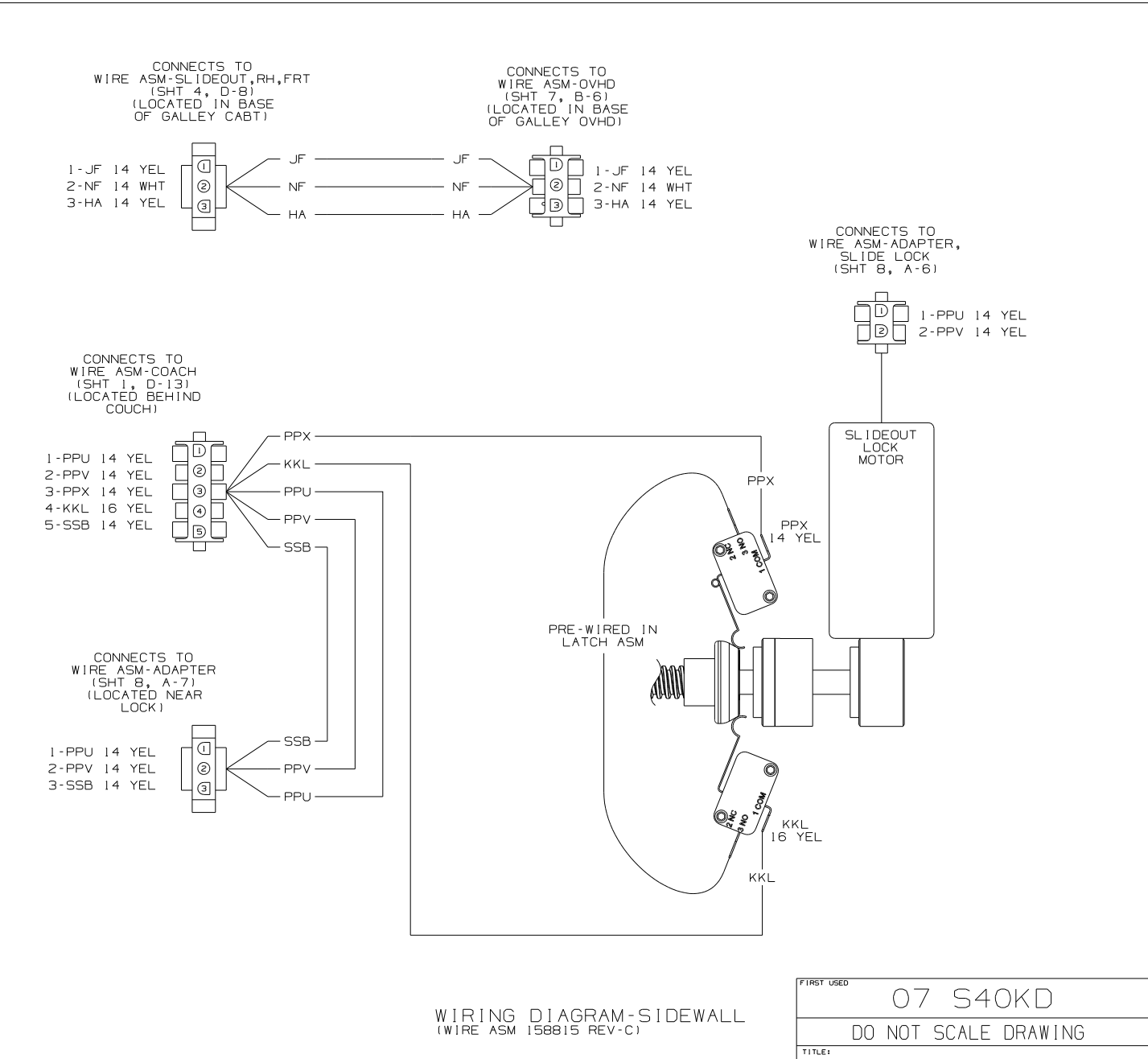
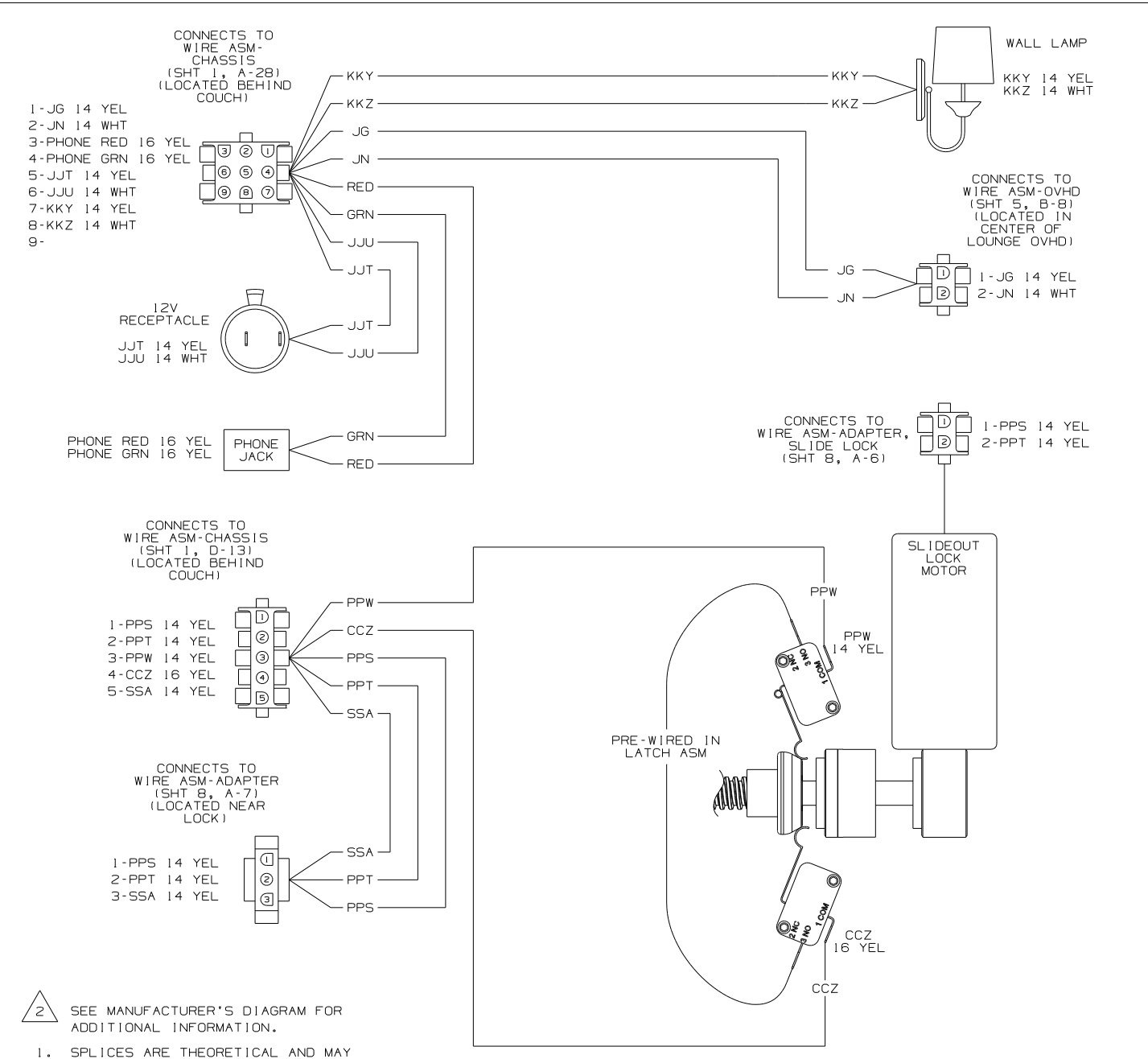
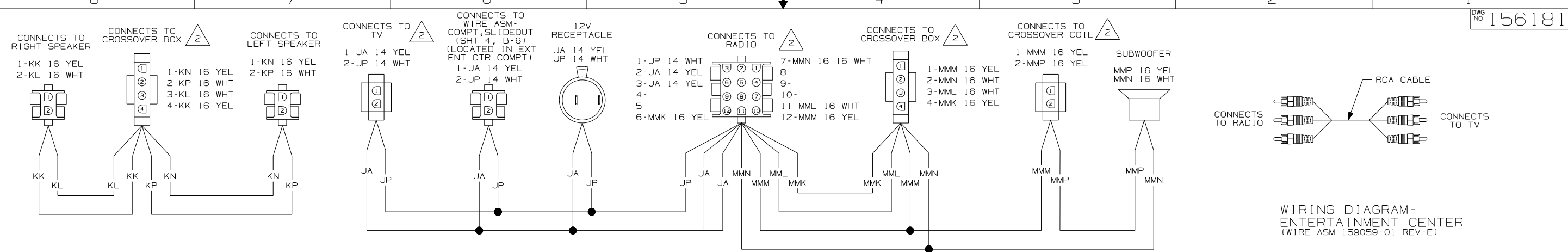

NOTES:
 1. SPLICES ARE THEORETICAL AND MAY DIFFER IN THE HARNESS.

FIRST USED	07 S40KD
DO NOT SCALE DRAWING	
TITLE:	WIRING DIAGRAM-BODY, 12V
SHEET 6	PART NO 156181
REV	

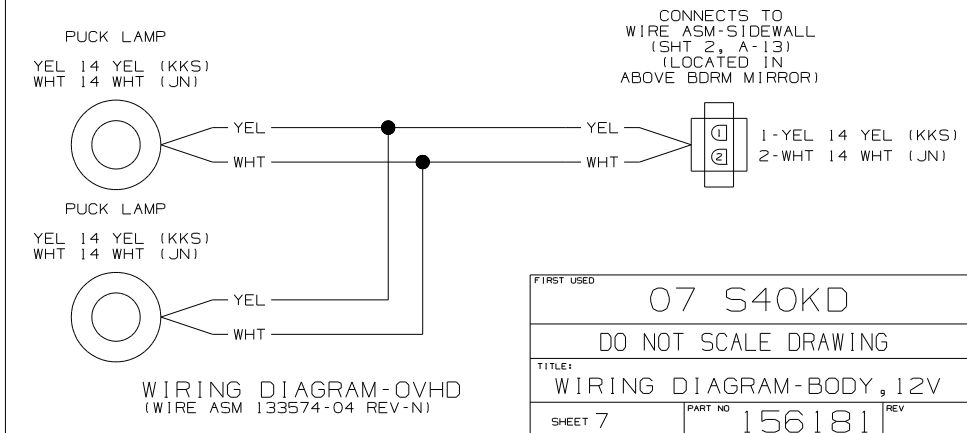
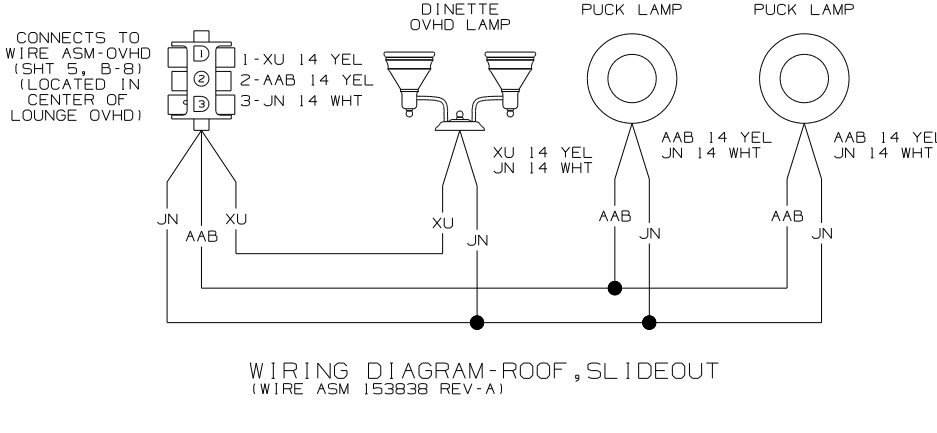
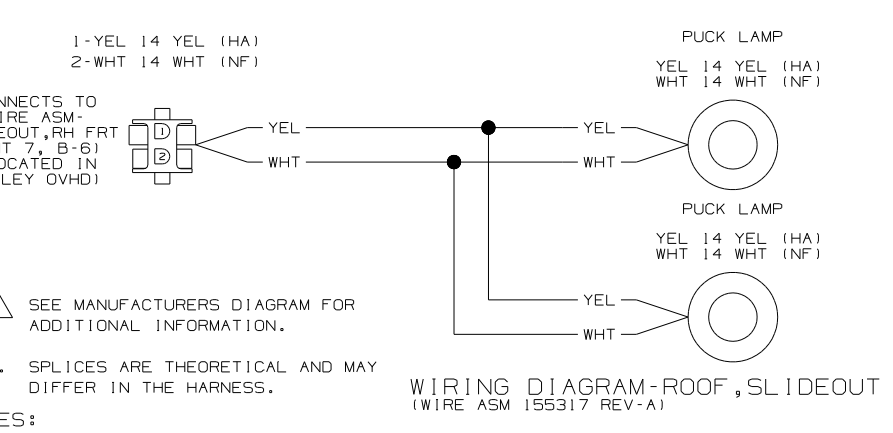
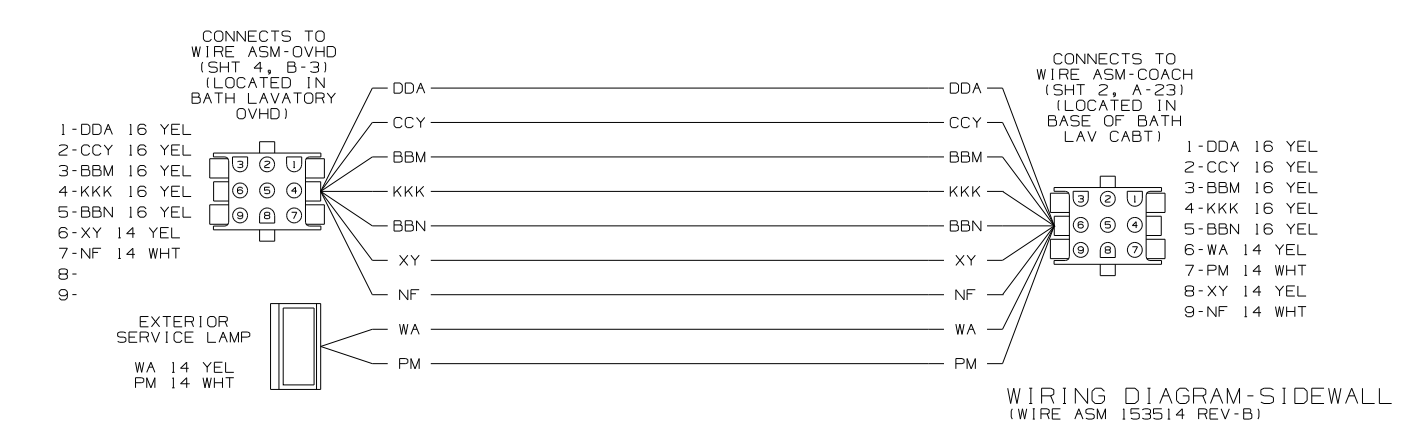
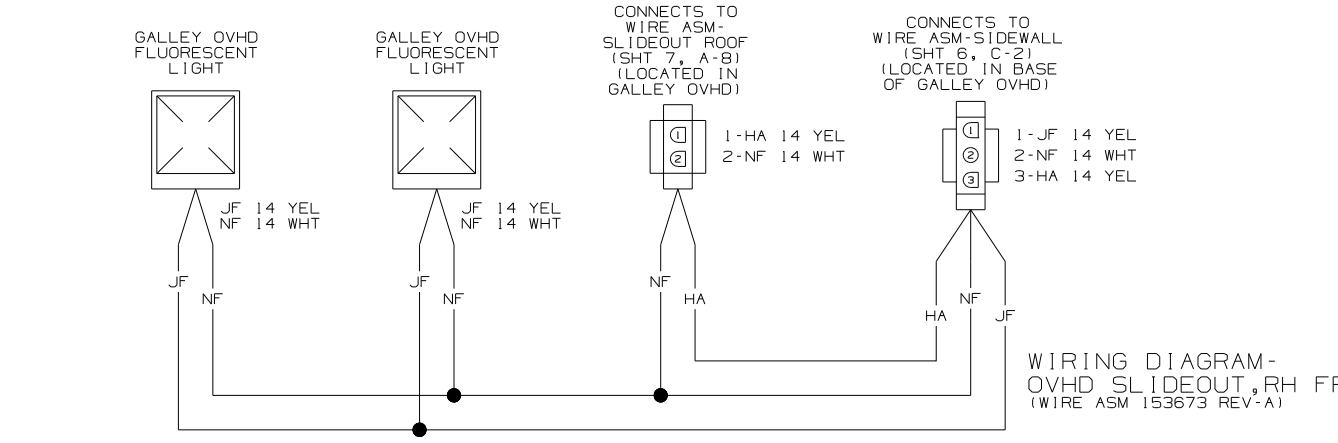
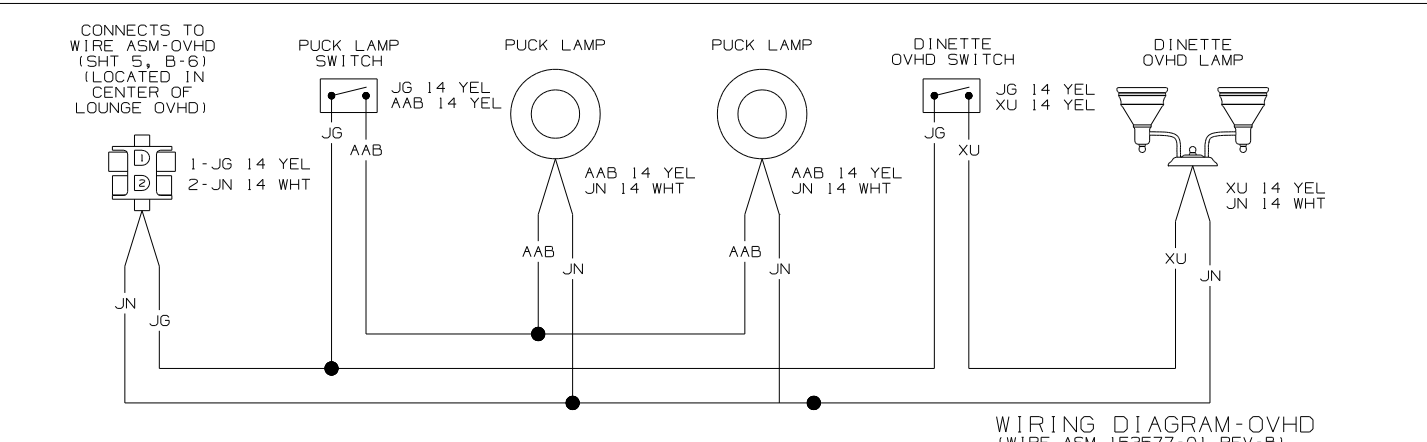
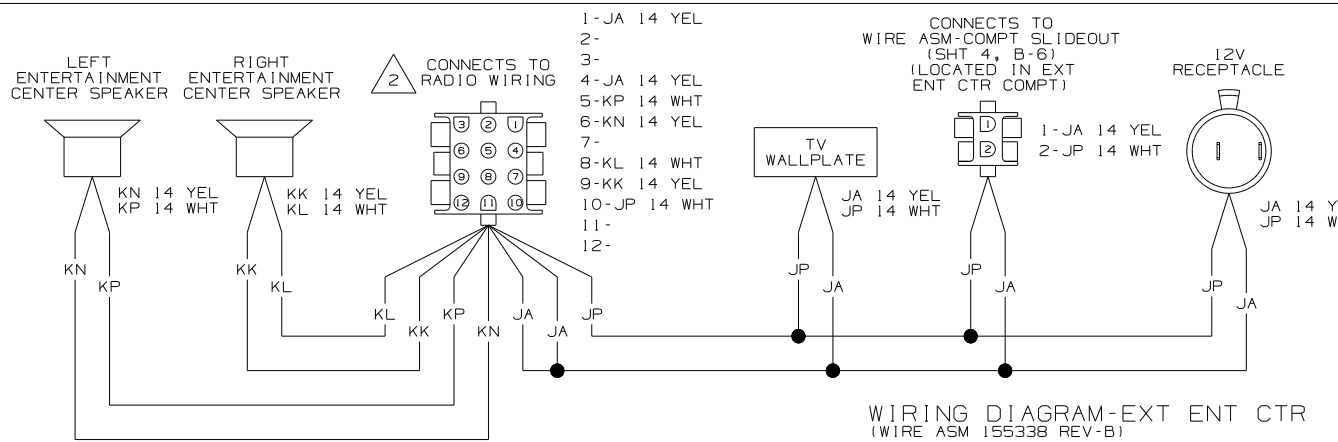
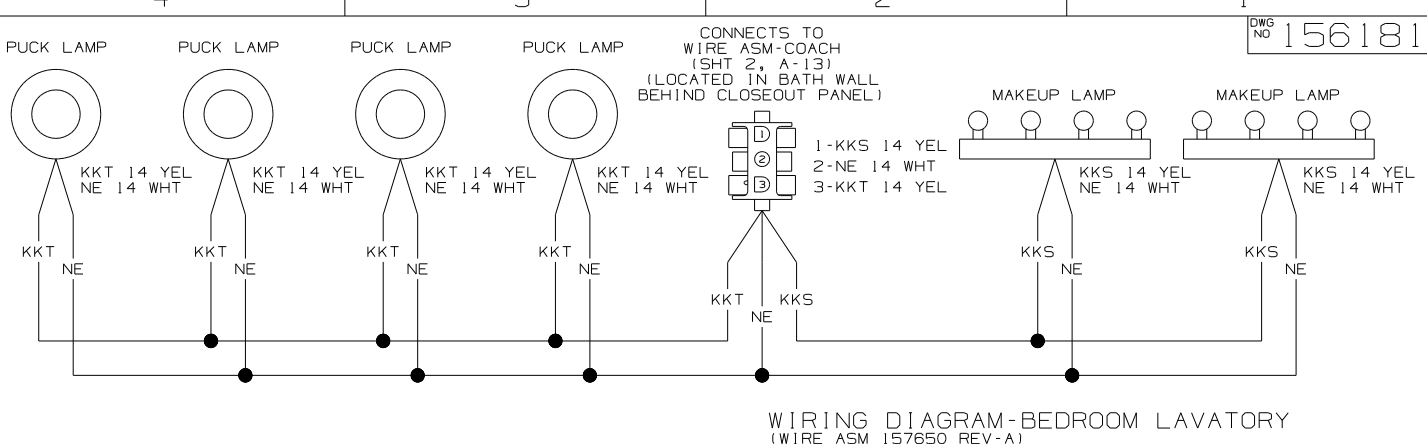
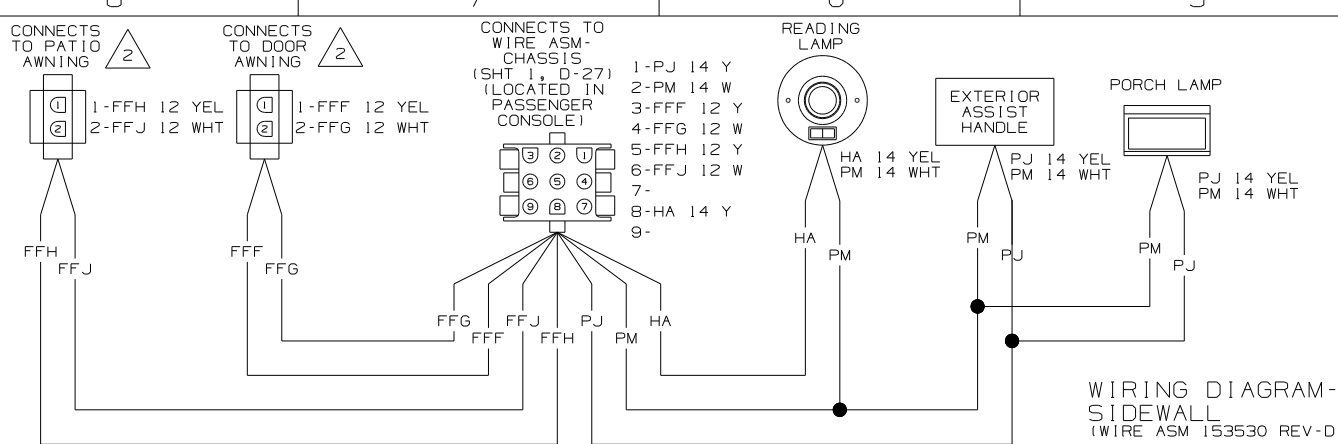

NOTES:
 1. SPLICES ARE THEORETICAL AND MAY DIFFER IN THE HARNESS.

FIRST USED	07 S40KD
TITLE	DO NOT SCALE DRAWING
TITLE	WIRING DIAGRAM-BODY, 12V
SHEET 7	PART NO 156181 REV

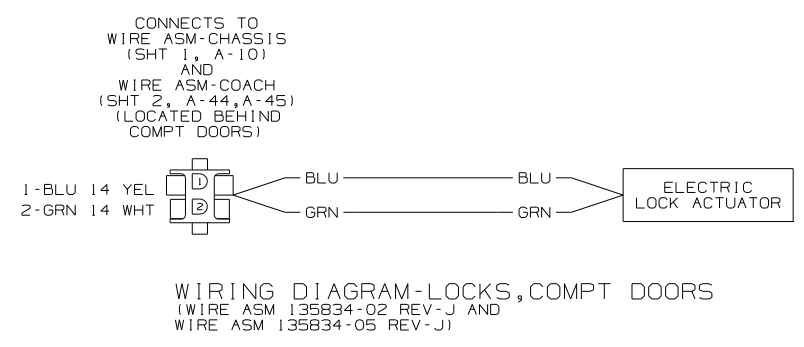
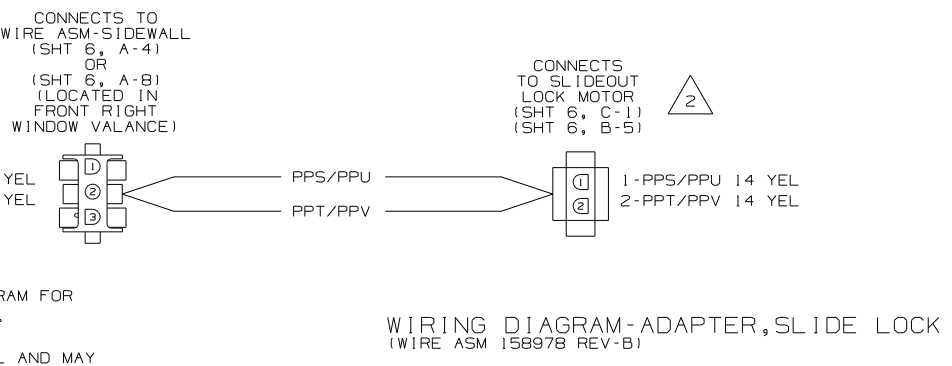
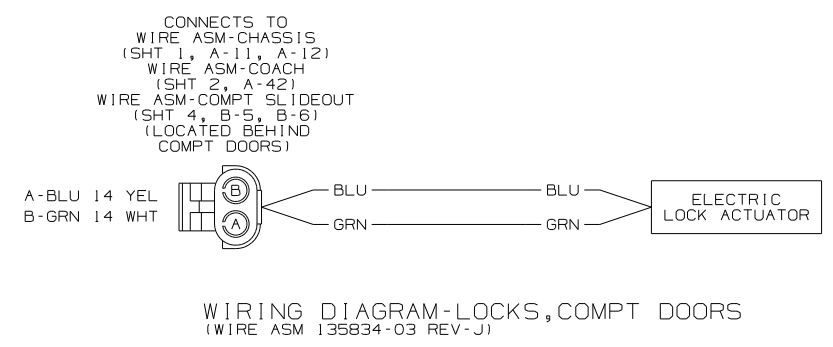
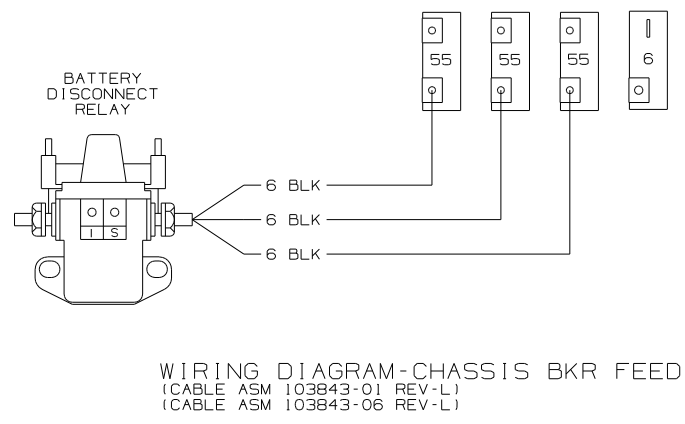
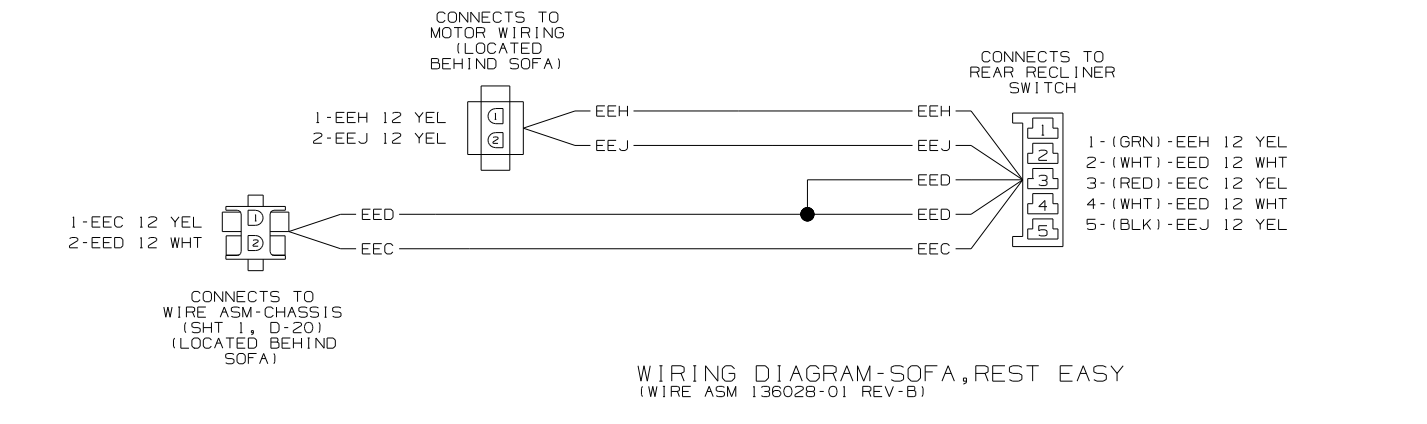
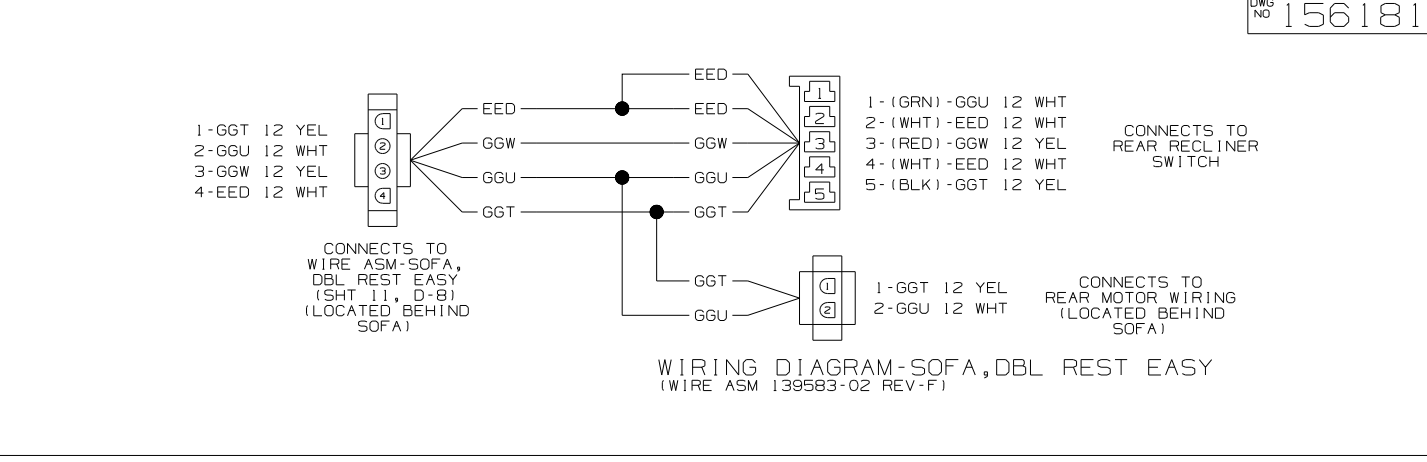
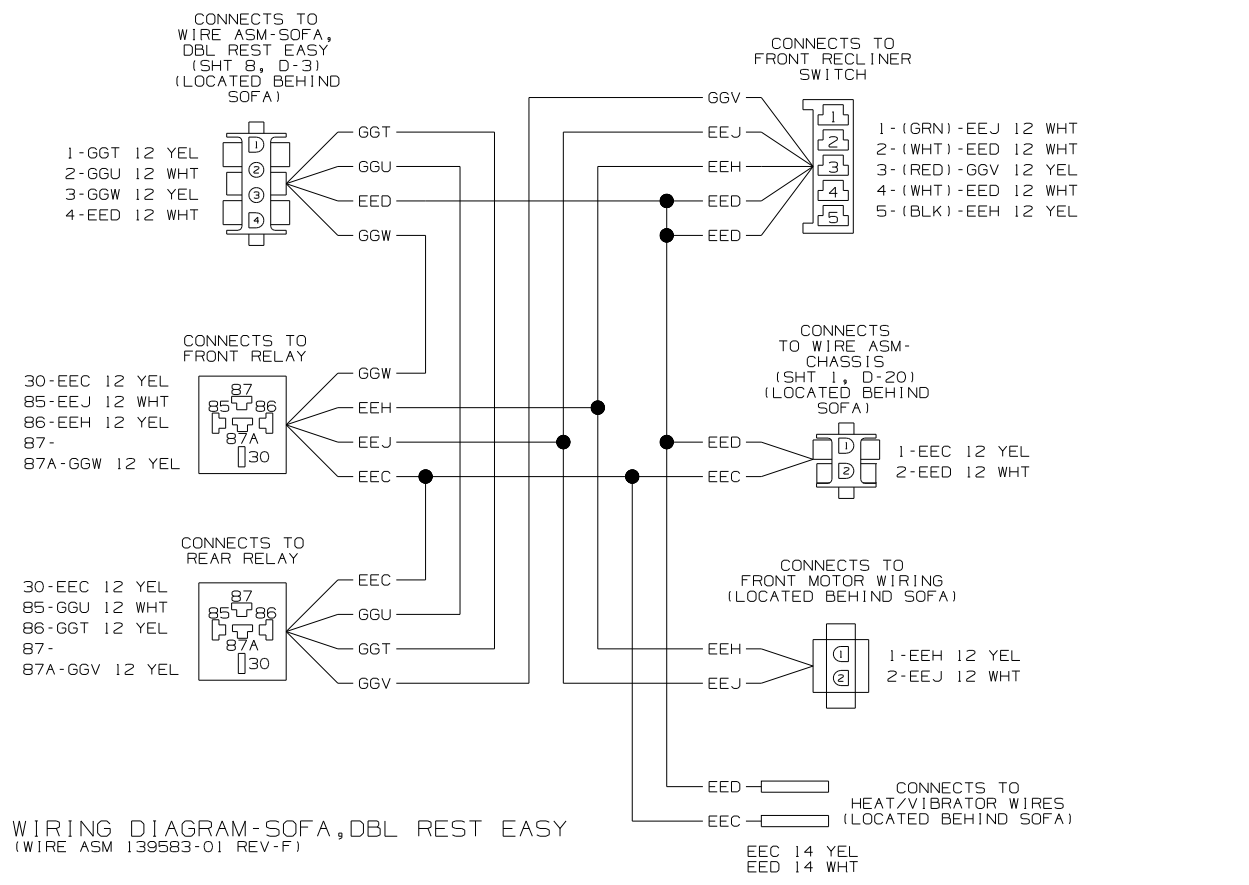

SEE MANUFACTURERS DIAGRAM FOR ADDITIONAL INFORMATION.

1. SPLICES ARE THEORETICAL AND MAY DIFFER IN THE HARNESS.

FIRST USED	07 S40KD		
TITLE	DO NOT SCALE DRAWING		
	WIRING DIAGRAM-BODY, 12V		
SHEET 8	PART NO	156181	REV