





























DANGER

Danger of electrical shock, burns or death. Always remove all power sources before attempting any repair, service or diagnostic work. Power can be present from shore power, generator, inverter or battery. All power sources must be disabled and secured before performing any service.



CAUTION

If you lack the skills, tools or equipment to perform diagnostic or repair work leave such work to an authorized Winnebago Industries dealer or other qualified shop.

8		7		6	
		R36LD	R40KD	R40FD	R40TD
RED	12-UL	136135-07-063	136135-07-063	136135-07-063	136135-07-116
	12-CA	136136-07-063	136136-07-063	136136-07-063	136136-07-116
MAIN	4-3 UL	136141-01-030	136141-01-030	136141-01-030	136141-01-110
	4-3 CA	136142-01-030	136142-01-030	136142-01-030	136142-01-110
GRN	12-UL	136135-08-063	136135-08-063	136135-08-063	136135-08-116
	12-CA	136136-08-063	136136-08-063	136136-08-063	136136-08-116
INVERTER CHARGER MAIN	10-UL	136137-01-035	136137-01-035	136137-01-035	136137-01-121
	10-CA	136138-01-035	136138-01-035	136138-01-035	136138-01-121
YEL	14-UL	136131-05-060	136131-05-060	136131-05-055	136131-05-135
	14-CA	136134-05-060	136134-05-060	136134-05-055	136134-05-135
YEL-2	14-UL	136131-13-065	136131-13-062	136131-13-061 	136131-13-135 
	14-CA	136134-13-065	136134-13-062	136134-13-061 	136134-13-135 
YEL-3	14-UL	136131-17-020	136131-17-020	136131-17-020	136131-17-020
	14-CA	136134-17-020	136134-17-020	136134-17-020	136134-17-020
GLD	12-UL	136135-10-105	136135-10-073	136135-10-076	136135-10-025
	12-CA	136136-10-105	136136-10-073	136136-10-076	136136-10-025
WHT	12 UL	136135-09-040	136135-09-040	136135-09-060	136135-09-040
	12 CA	136136-09-040	136136-09-040	136136-09-060	136136-09-040
INVERTER CHARGER SUB MAIN	10-UL	136137-01-035	136137-01-035	136137-01-035	136137-01-121
	10-CA	136138-01-035	136138-01-035	136138-01-035	136138-01-121
BLU	14-UL	136131-02-065 	136131-02-105 	136131-02-130 	136131-02-255
	14-CA	136134-02-065 	136134-02-105 	136134-02-130 	136134-02-255
BRN	14-UL	136131-03-135 	136131-03-140	136131-03-170 	136131-03-222
	14-CA	136134-03-135 	136134-03-140	136134-03-170 	136134-03-222
PUR	14-UL	136131-04-140	136131-04-080	136131-04-095	136131-04-098 
	14-CA	136134-04-140	136134-04-080	136134-04-095	136134-04-098 
ORG	14-UL	136131-16-125	136131-16-130	136131-16-155	136131-16-332
	14-CA	136134-16-125	136134-16-130	136134-16-155	136134-16-332
BLK	14-UL	136131-06-065 	136131-06-080 	136131-06-070 	136131-06-155
	14-CA	136134-06-065 	136134-06-080 	136134-06-070 	136134-06-155
GRY	14-UL	-----	-----	136131-15-061 	136131-15-080 
	14-CA	-----	-----	136134-15-061 	136134-15-080 
GROUND MAIN		136145-01-025	136145-01-025	136145-01-025	136145-01-107
GROUND SUB MAIN		136145-01-025	136145-01-025	136145-01-025	136145-01-107
GROUND ATS		136145-01-007	136145-01-007	136145-01-007	136145-01-007
GROUND INVERTER		136145-01-014	136145-01-014	136145-01-014	136145-01-010
CABLE ASM. GEN.		136148-02-105	136148-02-116	136148-02-116	136148-02-085
CONDUIT ASM-CENTRAL A/C		151704-01-032	151704-01-038	151704-01-038	151704-01-028

22T

54E 21M

14C

- 54E WASHER/DRYER
- 22T VACUUM SYSTEM - CENTRAL
- 14C FIREPLACE-ELECTRIC
- 21M WASHER/DRYER PREP
- 265 CODES/STANDARDS - CSA/CMVSS
- 1B1 CODES/STANDARDS - USA
- 1B1 265

WINNEBAGO COPYRIGHT 2006 WINNEBAGO INDUSTRIES, INC.

DFTR	ORIG. DATE
CHKR	ALL DIMENSIONS ARE IN MILLIMETERS
P.E.	FIRST USED
M.E.	07 R-SERIES
DSNR	

UNSPECIFIED TOLERANCES ARE:
 HOLE DIM (X) : 3
 ONE-PLACE (X.X) : 1.5
 TWO-PLACE (X.XX) : 0.50
 ANGLE : 1°

THIRD ANGLE PROJECTION 

DO NOT SCALE DRAWING

TITLE: LOAD CENTER/ATS ASM

SHEET 1 OF 3 PART NO. 157853 REV

REF: 1 5/15/2007

FOR ELECTRICAL TORQUE SPECIFICATIONS SEE DWG NO. 128783-01-000

FOR ELECTRICAL CALLOUTS SEE DWG NO. 121339-01-000

 SEE DETAIL BA FOR CONNECTOR INSTALLATION.
 NOTES:

		8	7	6	5	4	3	2	1
			R36LD	R40KD	R40FD	R40TD			
SLIDEOUT #1 WIRE #1			136151-03-055	136151-03-055	136151-03-042	136151-03-030			
SLIDEOUT #1 WIRE #2			-----	----	136151-06-042	136151-13-030			
SLIDEOUT #1 WIRE #3			-----	----	-----	-----			
SLIDEOUT #2 WIRE #1			136151-04-020	136151-04-017	136151-04-020	136151-04-022			
SLIDEOUT #2 WIRE #2			-----	-----	-----	136151-15-022 (14C)			
SLIDEOUT #3 WIRE #1			136151-02-020	136151-02-019	136151-02-055	-----			
SLIDEOUT #3 WIRE #2			136151-06-020	136151-06-019	136151-13-070	-----			
SLIDEOUT #3 WIRE #3			-----	-----	136151-02-018	-----			
SLIDEOUT #3 WIRE #4			136151-02-040	136151-02-045	136151-15-070 (14C)	-----			
SLIDEOUT #4 WIRE #1			-----	----	136151-04-020	-----			
THROW IN WIRE #1	14-UL		136131-04-050	136131-02-003	-----	136131-03-080			
	14-CA		136134-04-050	136134-02-003	-----	136134-03-080			
THROW IN WIRE #2	14-UL		136131-04-003	136131-02-060	136131-04-028	136131-04-105			
	14-CA		136134-04-003	136134-02-060	136134-04-028	136134-04-105			
THROW IN WIRE #3	14-UL		136131-02-025 (11C)	-----	-----	136131-13-015			
	14-CA		136134-02-025 (11C)	-----	-----	136134-13-015			
THROW IN WIRE #4	14-UL		136131-02-055	136131-04-003	-----	136131-15-065 (14C)			
	14-CA		136134-02-055	136134-04-003	-----	136134-15-065 (14C)			
THROW IN WIRE #5	14-UL		136131-02-013 (1D5) (1D3)	----	136131-04-080	-----			
	14-CA		136134-02-013 (1D5) (1D3)	----	136134-04-080	-----			
THROW IN WIRE #6	14-UL		-----	136131-03-048	136131-02-035	-----			
	14-CA		-----	136134-03-048	136134-02-035	-----			
THROW IN WIRE #7	14-UL		-----	136131-04-055	136131-03-032	-----			
	14-CA		-----	136134-04-055	136134-03-032	-----			
THROW IN WIRE #8	14-UL		136131-03-006	136131-02-017 (1D3) (1D5)	136131-04-030	-----			
	14-CA		136134-03-006	136134-02-017 (1D3) (1D5)	136134-04-030	-----			
THROW IN WIRE #9	14-UL		----	136131-02-050	136131-02-025 (1D3) (1D5)	-----			
	14-CA		----	136134-02-050	136134-02-025 (1D3) (1D5)	-----			
THROW IN WIRE #10	14-UL		----	----	136131-15-015 (14C)	-----			
	14-CA		----	----	136134-15-015 (14C)	-----			

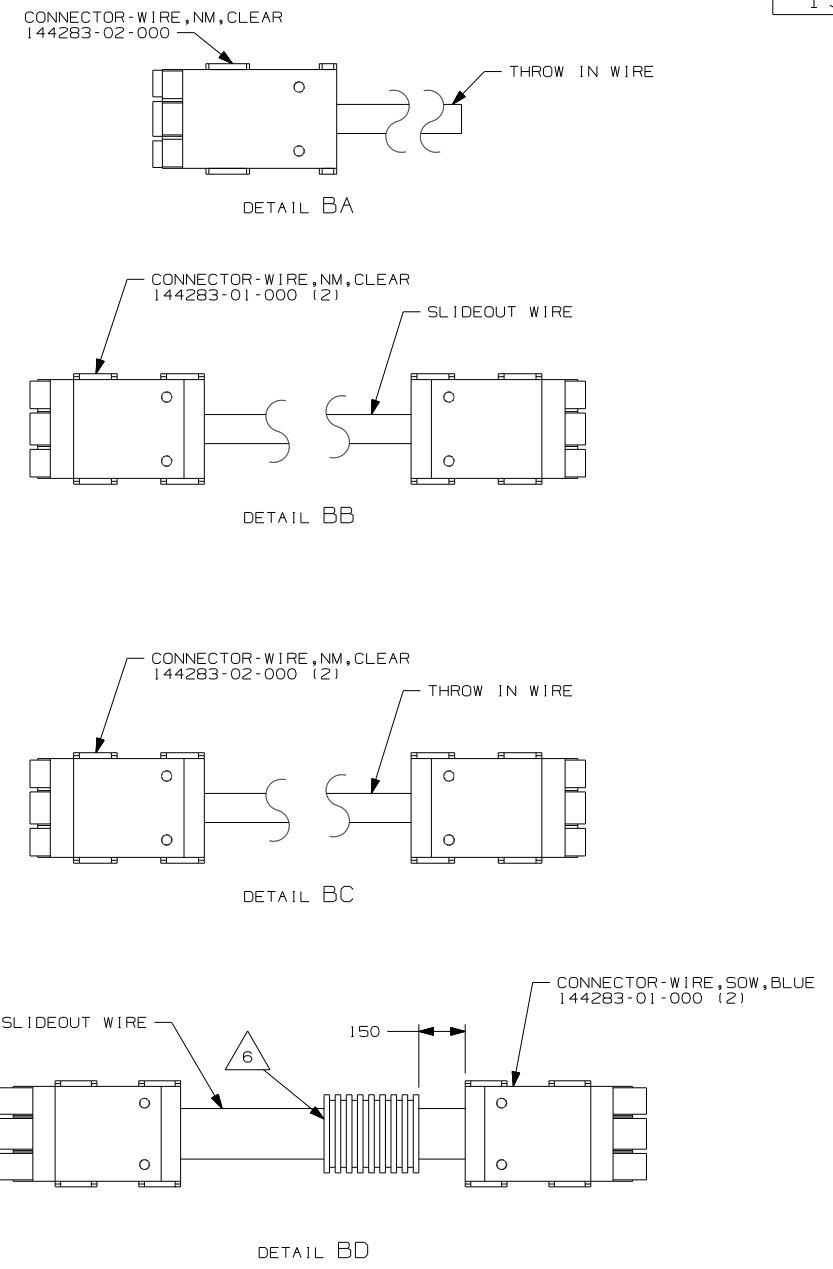

- (11C) BREAKFAST BAR
- (14J) LOUNGE CHAIR-EURO ULTRATHR
- (14D) LOUNGE CHAIR-EURO LEATHER
- (440) LOUNGE CHAIR WITH CABINET
- (1D5) ENTERTAINMENT CENTR/EXT W/CD
- (1D3) ENTERTAIN CENTR/EXT TV-DVD
- (14C) FIREPLACE-ELECTRIC
- (265) CODES/STANDARDS-CSA/CMVSS
- (1B1) CODES/STANDARDS-USA

NOTES:

SEE DETAIL BB FOR CONNECTOR INSTALLATION.

SEE DETAIL BA FOR CONNECTOR INSTALLATION.

SEE DETAIL BD FOR CONNECTOR INSTALLATION.

WITH (440) OR (14D) OR (14J)

SEE DETAIL BC FOR CONNECTOR INSTALLATION.

APPLY 300MM OF CONDUIT-CONVOLUTE 41953-05-000 OVER WIRE AT DIMENSION SHOWN AND SECURE BOTH ENDS OF TUBING TO WIRE WITH TAPE 8363-01-000.

FOR ELECTRICAL TORQUE SPECIFICATIONS SEE DWG NO. 128783-01-000

FOR ELECTRICAL CALLOUTS SEE DWG NO. 121339-01-000

FIRST USED

07 R-SERIES

DO NOT SCALE DRAWING

TITLE: **LOAD CENTER/ATS ASM**

SHEET 2 PART NO **157853** REV

1 5/15/2007

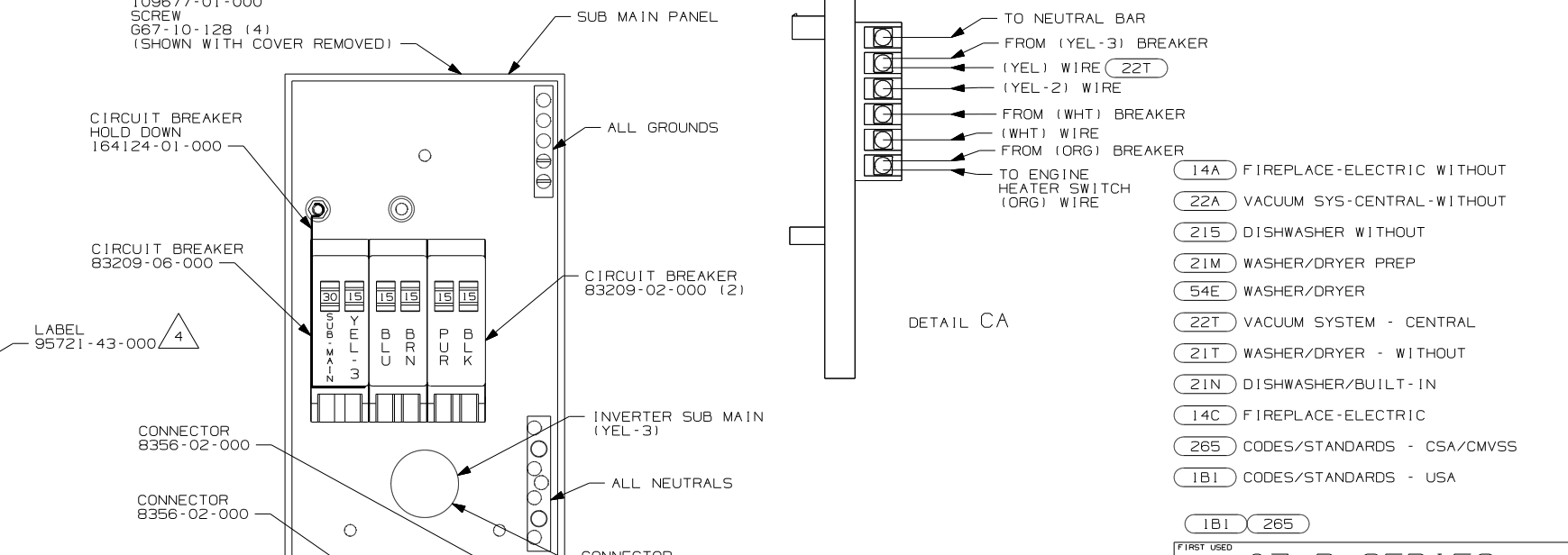
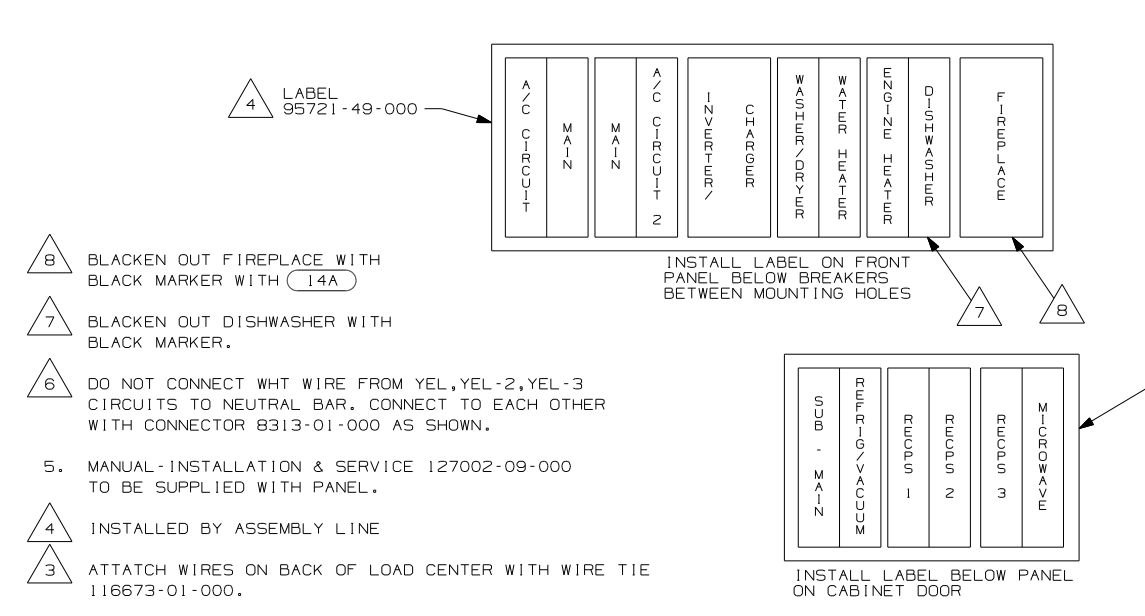
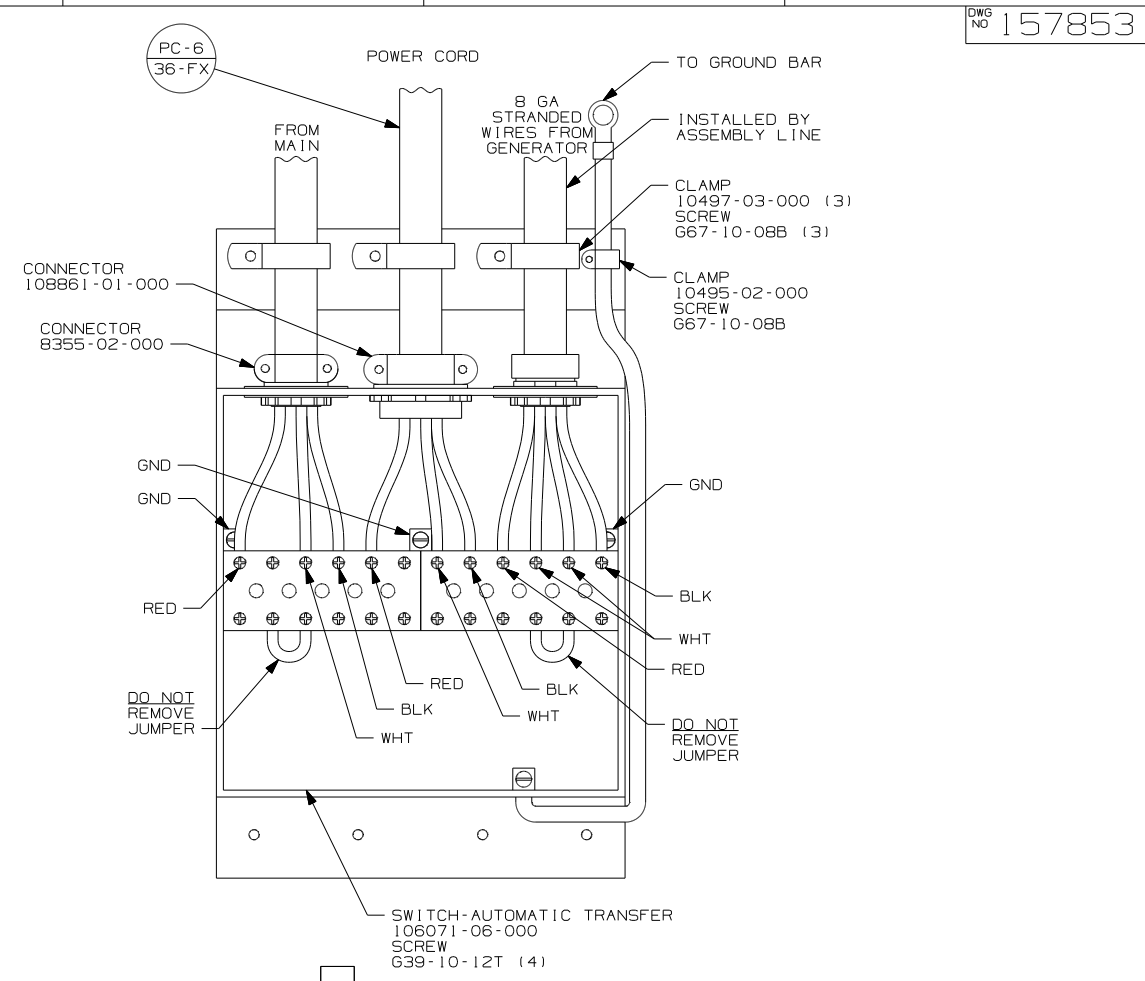
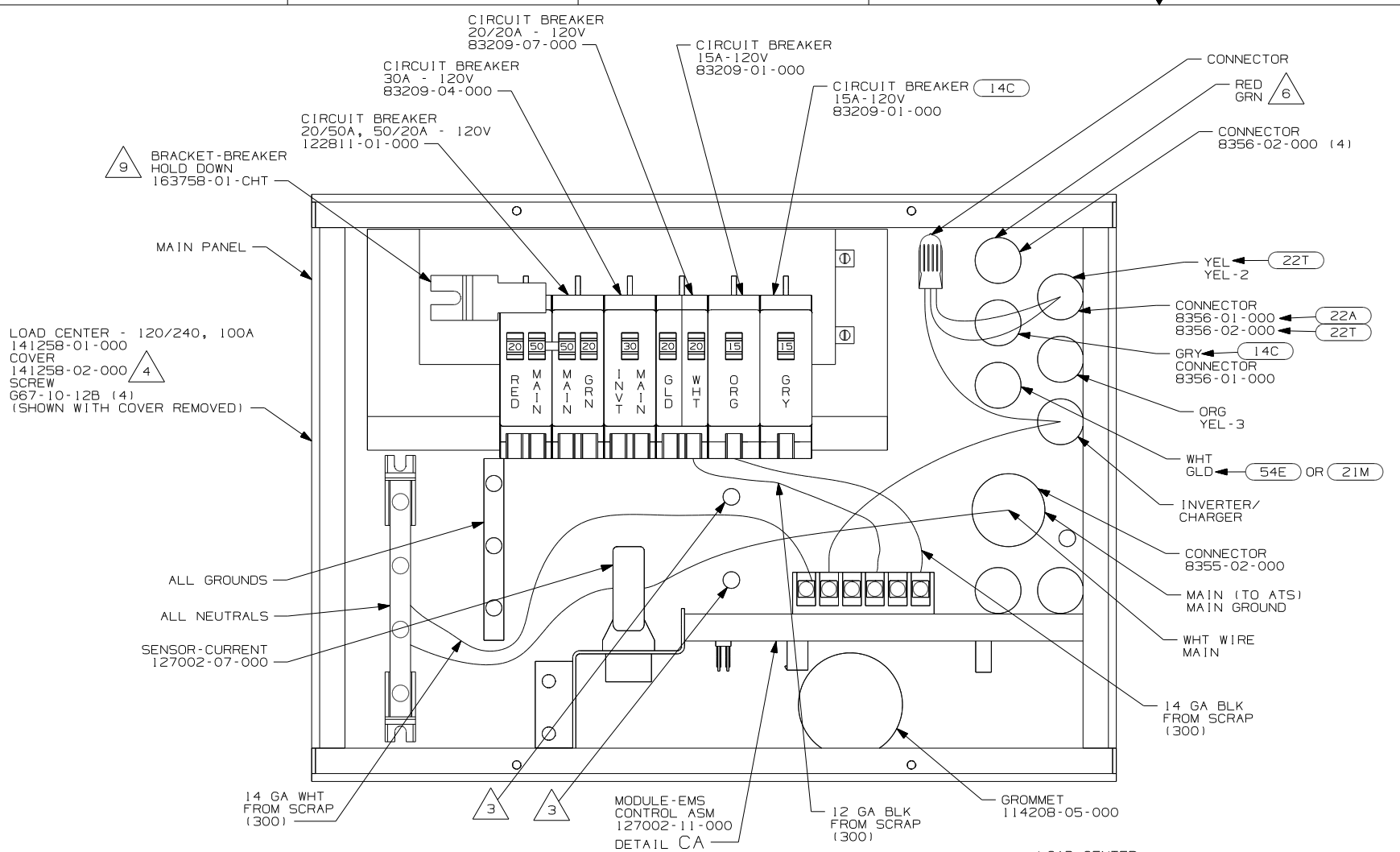

- NOTES:
1. ALL GROUND WIRES TO BE COVERED WITH TUBING 8041-02-000.
 2. REMOVE 400MM FROM OUTER JACKET ON ALL WIRES ENTERING LOAD CENTER AND TRIM INDIVIDUAL CONDUCTORS AS REQUIRED TO MAKE INTERNAL CONNECTIONS
 3. ATTATCH WIRES ON BACK OF LOAD CENTER WITH WIRE TIE 116673-01-000.
 4. INSTALLED BY ASSEMBLY LINE
 5. MANUAL-INSTALLATION & SERVICE 127002-09-000 TO BE SUPPLIED WITH PANEL.
 6. DO NOT CONNECT WHT WIRE FROM YEL,YEL-2,YEL-3 CIRCUITS TO NEUTRAL BAR. CONNECT TO EACH OTHER WITH CONNECTOR 8313-01-000 AS SHOWN.
 7. BLACKEN OUT DISHWASHER WITH BLACK MARKER.
 8. BLACKEN OUT FIREPLACE WITH BLACK MARKER WITH (14A)
 9. LOOSEN LEFT BUSS BAR MOUNTING SCREW, INSERT BRACKET-BREAKER HOLD DOWN UNDER SCREW, ORIENTATE BRACKET TOWARD MAIN BREAKER AS SHOWN AND TIGHTEN SCREW.

FOR ELECTRICAL TORQUE SPECIFICATIONS SEE DWG NO. 128783-01-000

FOR ELECTRICAL CALLOUTS SEE DWG NO. 121339-01-000

FIRST USED	
07 R-SERIES	
DO NOT SCALE DRAWING	
TITLE: LOAD CENTER/ATS ASM	
SHEET 3	PART NO 157853
REV	