



DANGER

Danger of electrical shock, burns or death. Always remove all power sources before attempting any repair, service or diagnostic work. Power can be present from shore power, generator, inverter or battery. All power sources must be disabled and secured before performing any service.



CAUTION

If you lack the skills, tools or equipment to perform diagnostic or repair work leave such work to an authorized Winnebago Industries dealer or other qualified shop.

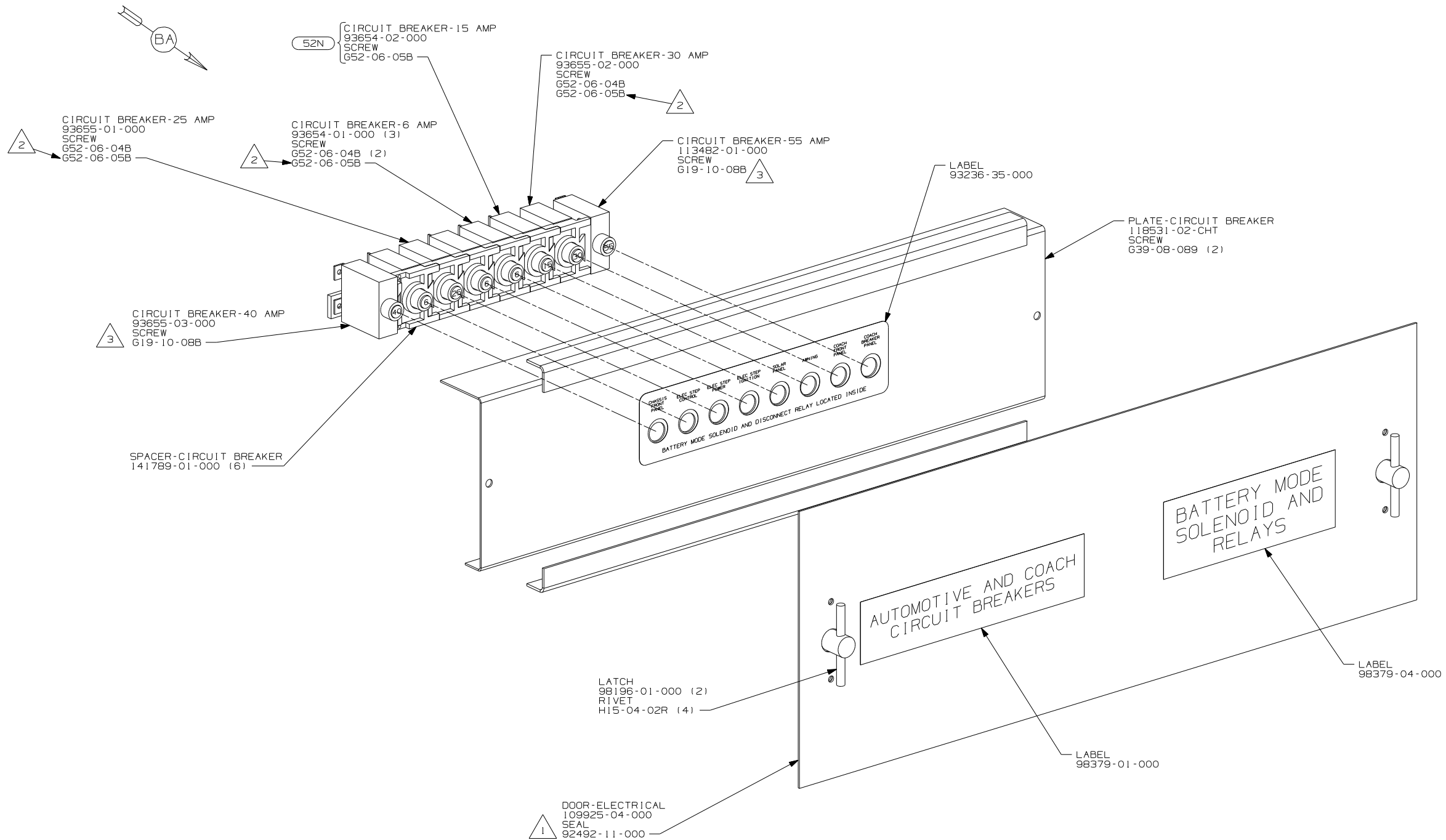

- NOTES:
- 3 REPLACE EXISTING SCREW TO PROPERLY ATTACH BREAKER TO BUSS BAR.
 - 2 USE THE LONGER SCREW TO PROPERLY ATTACH BREAKER TO BUSS BAR.
 - 1 PLACE AROUND ENTIRE PERIMETER OF DOOR WITH SEAM AT BOTTOM.

- 52N AWNING - PATIO, ELECTRIC
- 265 CODES/STANDARDS-CSA/CMVSS
- 1B1 CODES/STANDARDS USA

1B1 265

WINNEBAGO COPYRIGHT 2006 WINNEBAGO INDUSTRIES, INC.

DFTR	ORIG. DATE
CHKR	ALL DIMENSIONS ARE IN MILLIMETERS
P.E.	
M.E.	FIRST USED
DSNR	07 G-SERIES

UNSPECIFIED TOLERANCES ARE:	MATERIAL:
HOLE DIM (X) :	
ONE-PLACE (X.X) :	
TWO-PLACE (X.XX) :	
ANGLE :	

THIRD ANGLE PROJECTION

DO NOT SCALE DRAWING

TITLE: CHASSIS ELECTRICAL BOX ASM

SHEET 1 OF 2 PART NO 157460 REV

REF: 1 6/16/2006

FOR ELECTRICAL TORQUE SPECIFICATIONS SEE DWG NO. 128783-01-000

X-X FOR ELECTRICAL CALLOUTS SEE DWG NO. 121339-01-000

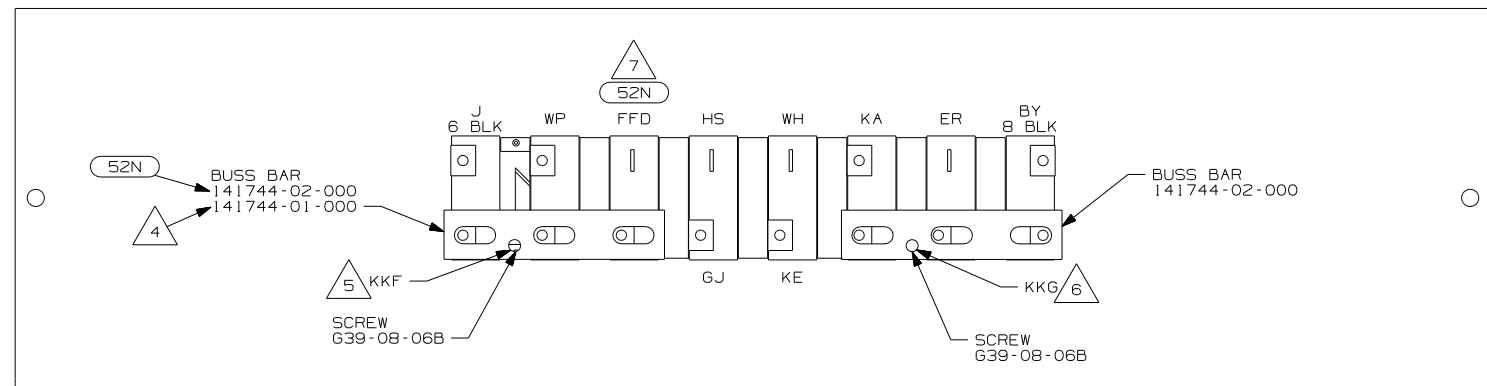

DETAIL BA

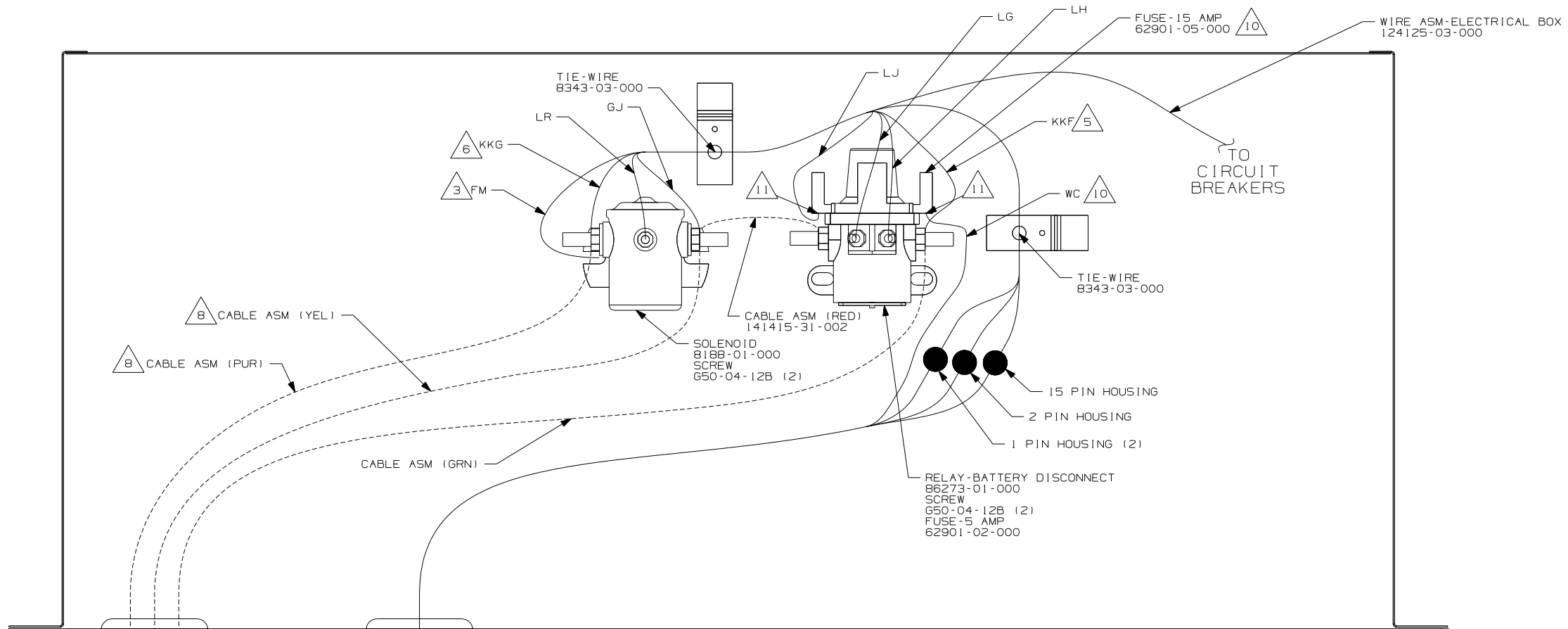

- 11. INSERT TERMINAL FROM CIRCUIT LJ OR WC INTO FUSE HOLDER ON RELAY-BATTERY DISCONNECT.
- 10. USED ON F38S ONLY.
- 9. SEE WIRING INSTL-CHASSIS FOR ADDITIONAL INFORMATION.
- 8. SEE BATTERY INSTL FOR ADDITIONAL INFORMATION.
- 7. IF CIRCUIT IS NOT USED, TAPE BACK TO HARNESS.
- 6. WIRE MARKED WITH PURPLE TAPE.
- 5. WIRE MARKED WITH YELLOW TAPE.
- 4. WITHOUT 52N
- 3. SECURE WITH SOLENOID MOUNTING SCREW.

2. SECURE CONDUIT 41953-09, -10, -11, -13, AND -14 OVER ALL WIRES IN CONTACT WITH SHARP EDGES.

1. LEGEND: — WINNEBAGO; - - - CABLE; - - - CHASSIS SUPPLIED WIRING.

52N AWNING - PAT10, ELECTRIC
 265 CODES/STANDARDS-CSA/CMVSS
 1B1 CODES/STANDARDS USA

1B1 265	
FIRST USED	
07 G-SERIES	
DO NOT SCALE DRAWING	
TITLE:	
CHASSIS ELECTRICAL BOX ASM	
SHEET 2	PART NO 157460 REV

FOR ELECTRICAL TORQUE SPECIFICATIONS SEE DWG NO. 128783-01-000

FOR ELECTRICAL CALLOUTS SEE DWG NO. 121339-01-000