



DANGER

Danger of electrical shock, burns or death. Always remove all power sources before attempting any repair, service or diagnostic work. Power can be present from shore power, generator, inverter or battery. All power sources must be disabled and secured before performing any service.



CAUTION

If you lack the skills, tools or equipment to perform diagnostic or repair work leave such work to an authorized Winnebago Industries dealer or other qualified shop.

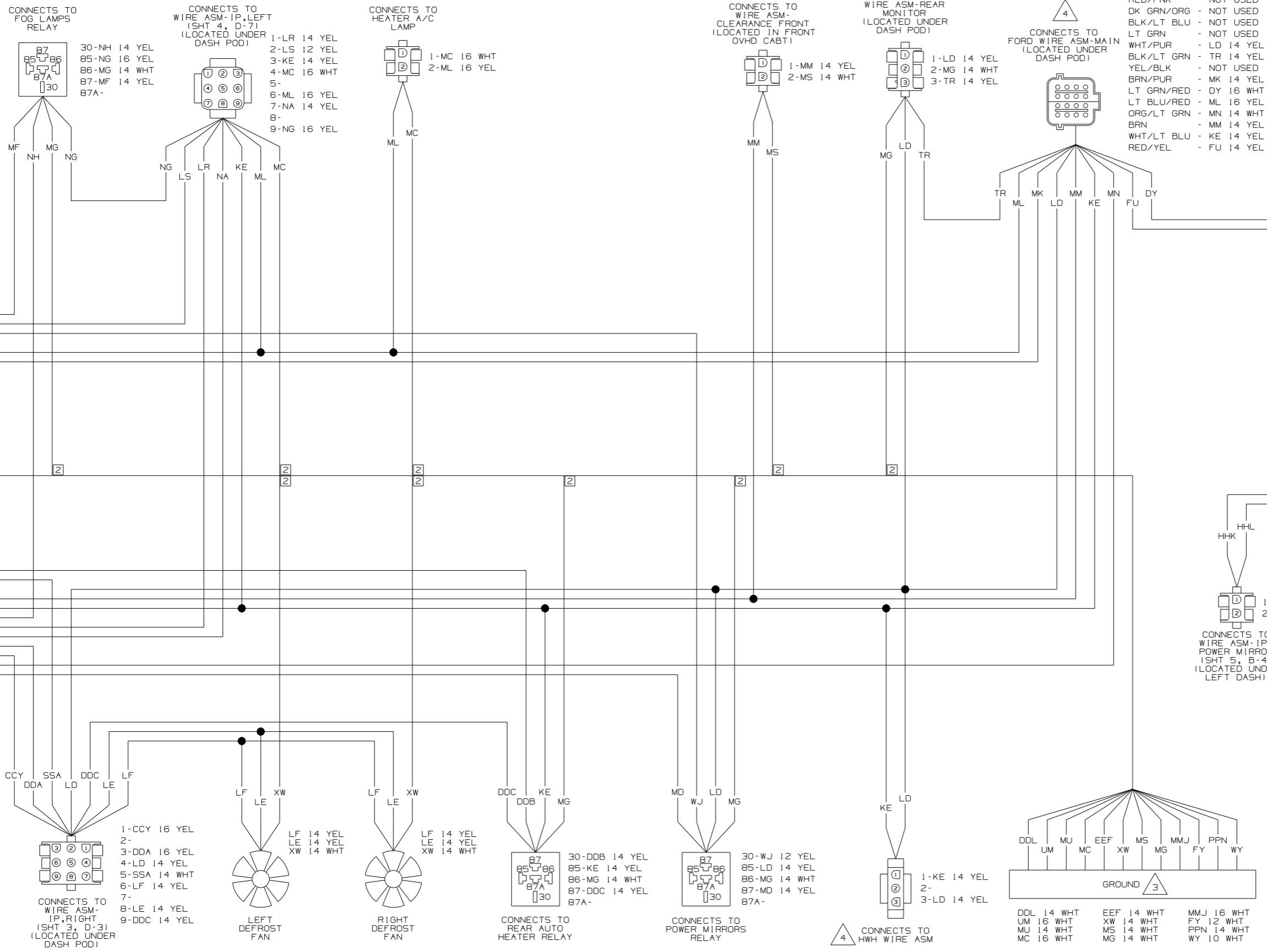

- LT BLU/WHT - NOT USED
- BRN/LT BLU - NOT USED
- RED/PNK - NOT USED
- DK GRN/ORG - NOT USED
- BLK/LT BLU - NOT USED
- LT GRN - NOT USED
- WHT/PUR - LD 14 YEL
- BLK/LT GRN - TR 14 YEL
- YEL/BLK - NOT USED
- BRN/PUR - MK 14 YEL
- LT GRN/RED - DY 16 WHT
- LT BLU/RED - ML 16 YEL
- ORG/LT GRN - MN 14 WHT
- BRN - MM 14 YEL
- WHT/LT BLU - KE 14 YEL
- RED/YEL - FU 14 YEL

WINNEBAGO COPYRIGHT 2006 WINNEBAGO INDUSTRIES, INC.

07 G-SERIES

UNSPECIFIED TOLERANCES ARE:

WHOLE DIM (XX) :
ONE-PLACE (X.X) :
TWO-PLACE (X.XX) :
ANGLE :

THIRD ANGLE PROJECTION

DO NOT SCALE DRAWING

TITLE: **WIRING DIAGRAM-AUTO**

SHEET 1 of 5 PART NO 157305 REV

REF: 1 7/20/2006

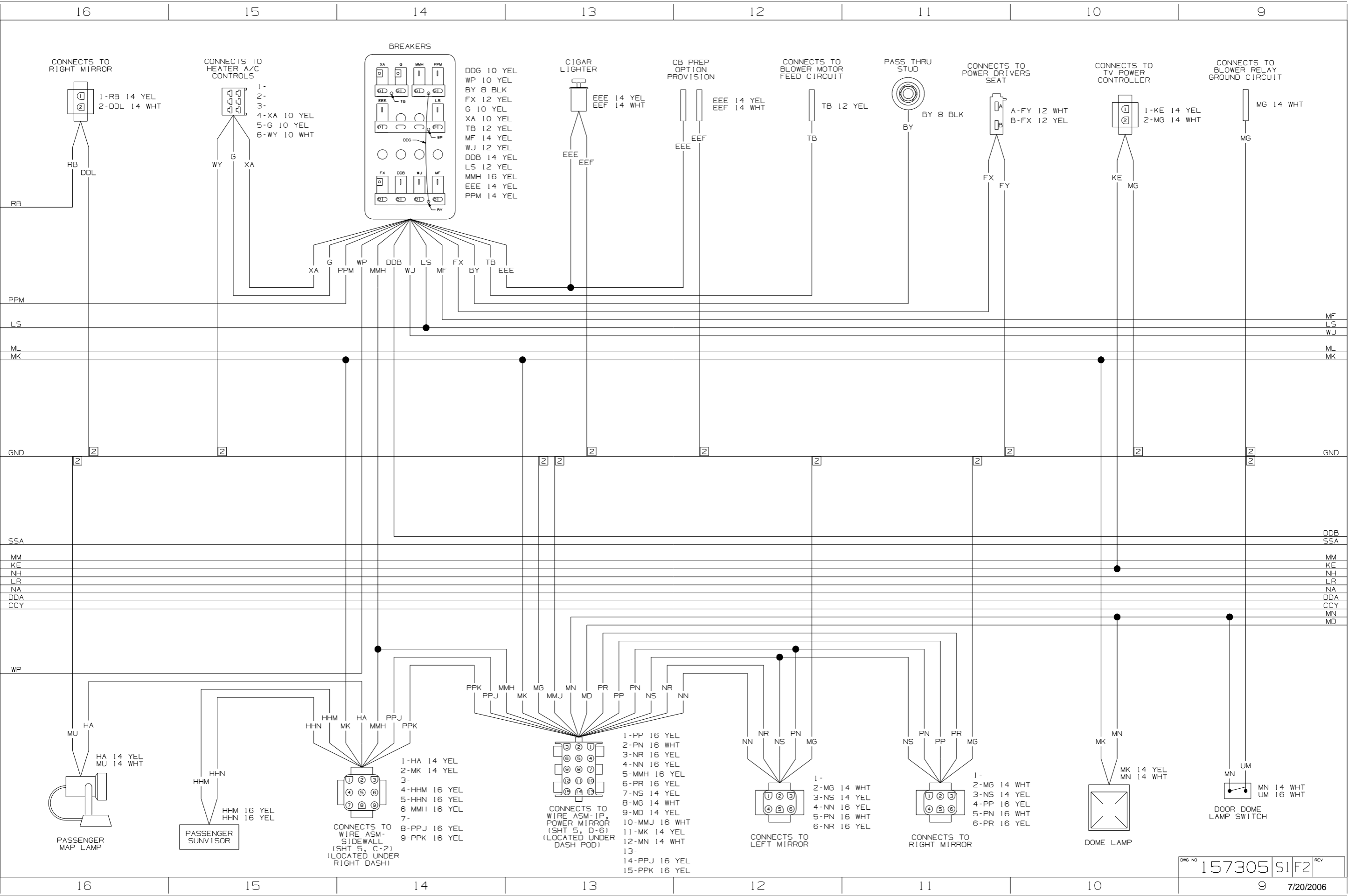

CONNECTS TO RIGHT MIRROR

CONNECTS TO HEATER A/C CONTROLS

BREAKERS

CIGAR LIGHTER

CB PREP OPTION PROVISION

CONNECTS TO BLOWER MOTOR FEED CIRCUIT

PASS THRU STUD

CONNECTS TO POWER DRIVERS SEAT

CONNECTS TO TV POWER CONTROLLER

CONNECTS TO BLOWER RELAY GROUND CIRCUIT

- 1-RB 14 YEL
- 2-DDL 14 WHT

- 1-
- 2-
- 3-
- 4-XA 10 YEL
- 5-G 10 YEL
- 6-WY 10 WHT

- DDG 10 YEL
- WP 10 YEL
- BY 8 BLK
- FX 12 YEL
- G 10 YEL
- XA 10 YEL
- TB 12 YEL
- MF 14 YEL
- WJ 12 YEL
- DOB 14 YEL
- LS 12 YEL
- MMH 16 YEL
- EEE 14 YEL
- PPM 14 YEL

- EEE 14 YEL
- EEF 14 WHT

- EEE 14 YEL
- EEF 14 WHT

- TB 12 YEL

- BY 8 BLK

- A-FY 12 WHT
- B-FX 12 YEL

- 1-KE 14 YEL
- 2-MG 14 WHT

- MG 14 WHT

- XA
- G
- PPM
- MMH
- WJ
- LS
- MF
- FX
- BY
- TB
- EEE

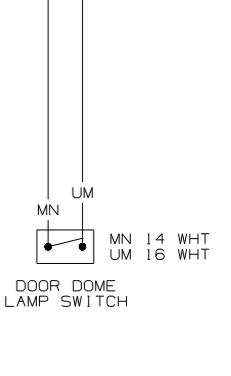
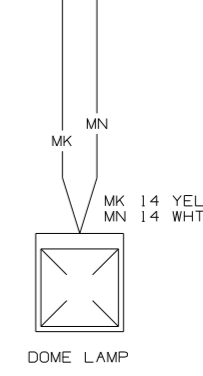
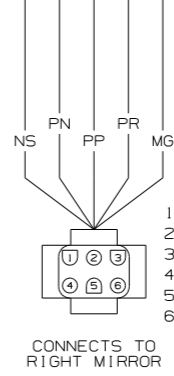
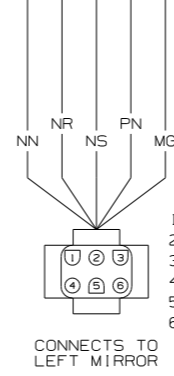
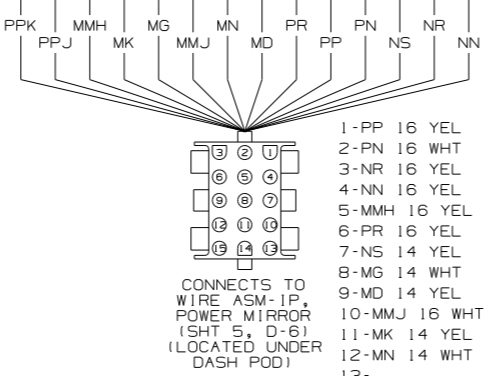
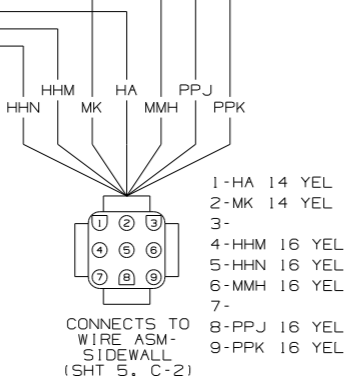
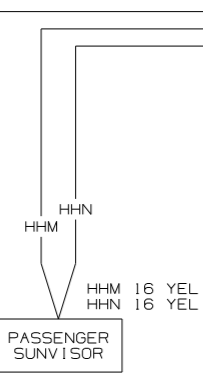
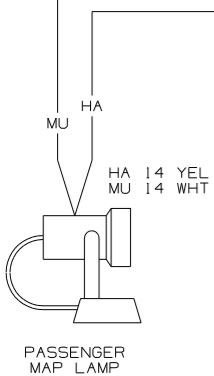
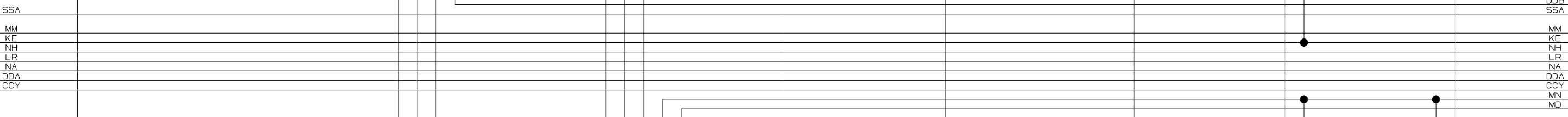
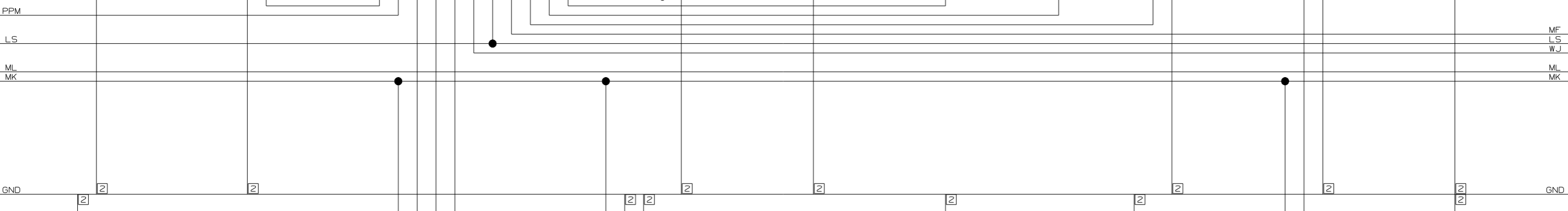

D
C
B
A

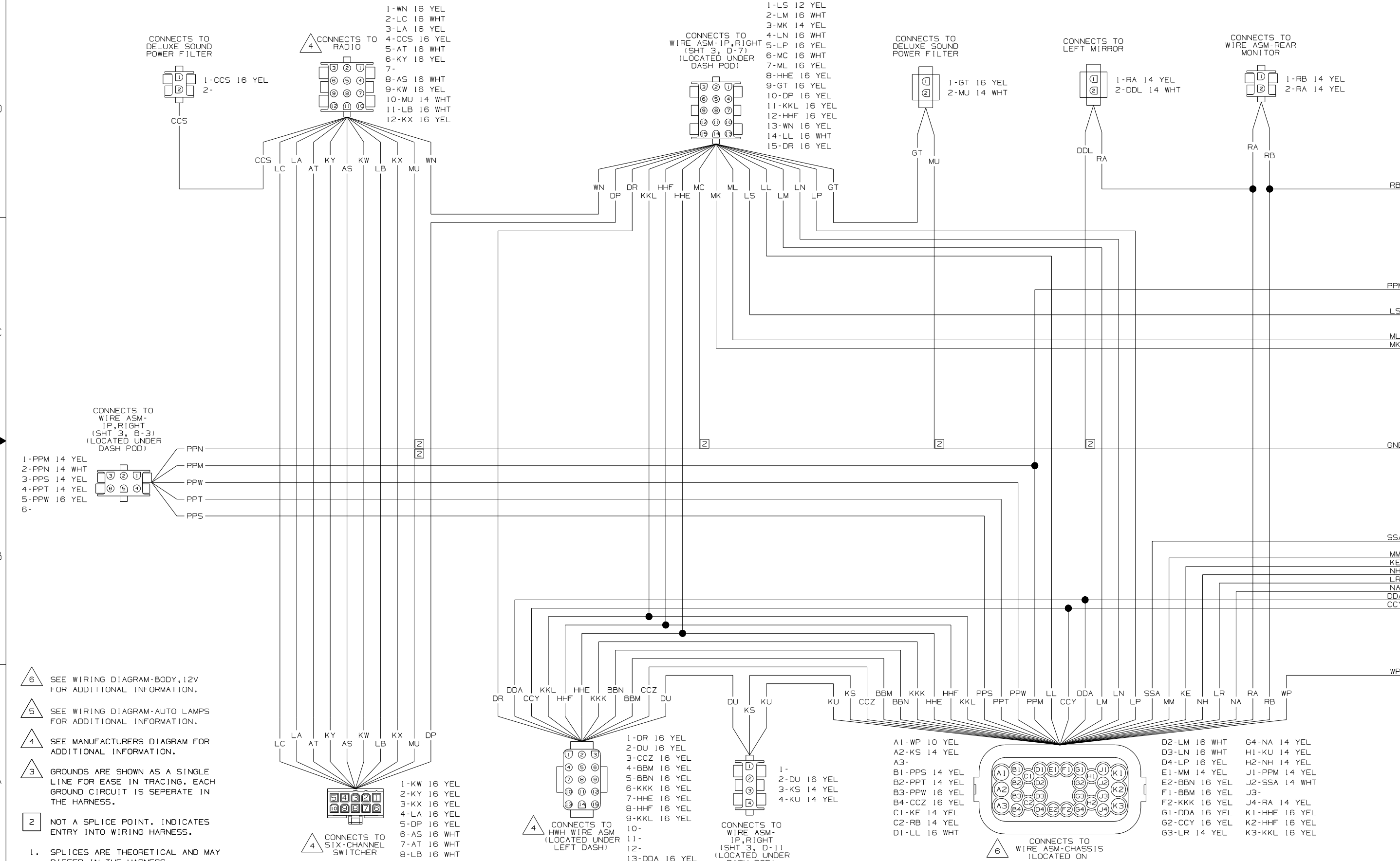

- 6 SEE WIRING DIAGRAM-BODY,12V FOR ADDITIONAL INFORMATION.
- 5 SEE WIRING DIAGRAM-AUTO LAMPS FOR ADDITIONAL INFORMATION.
- 4 SEE MANUFACTURERS DIAGRAM FOR ADDITIONAL INFORMATION.
- 3 GROUNDS ARE SHOWN AS A SINGLE LINE FOR EASE IN TRACING. EACH GROUND CIRCUIT IS SEPERATE IN THE HARNESS.
- 2 NOT A SPLICE POINT. INDICATES ENTRY INTO WIRING HARNESS.
1. SPLICES ARE THEORETICAL AND MAY DIFFER IN THE HARNESS.

NOTES:

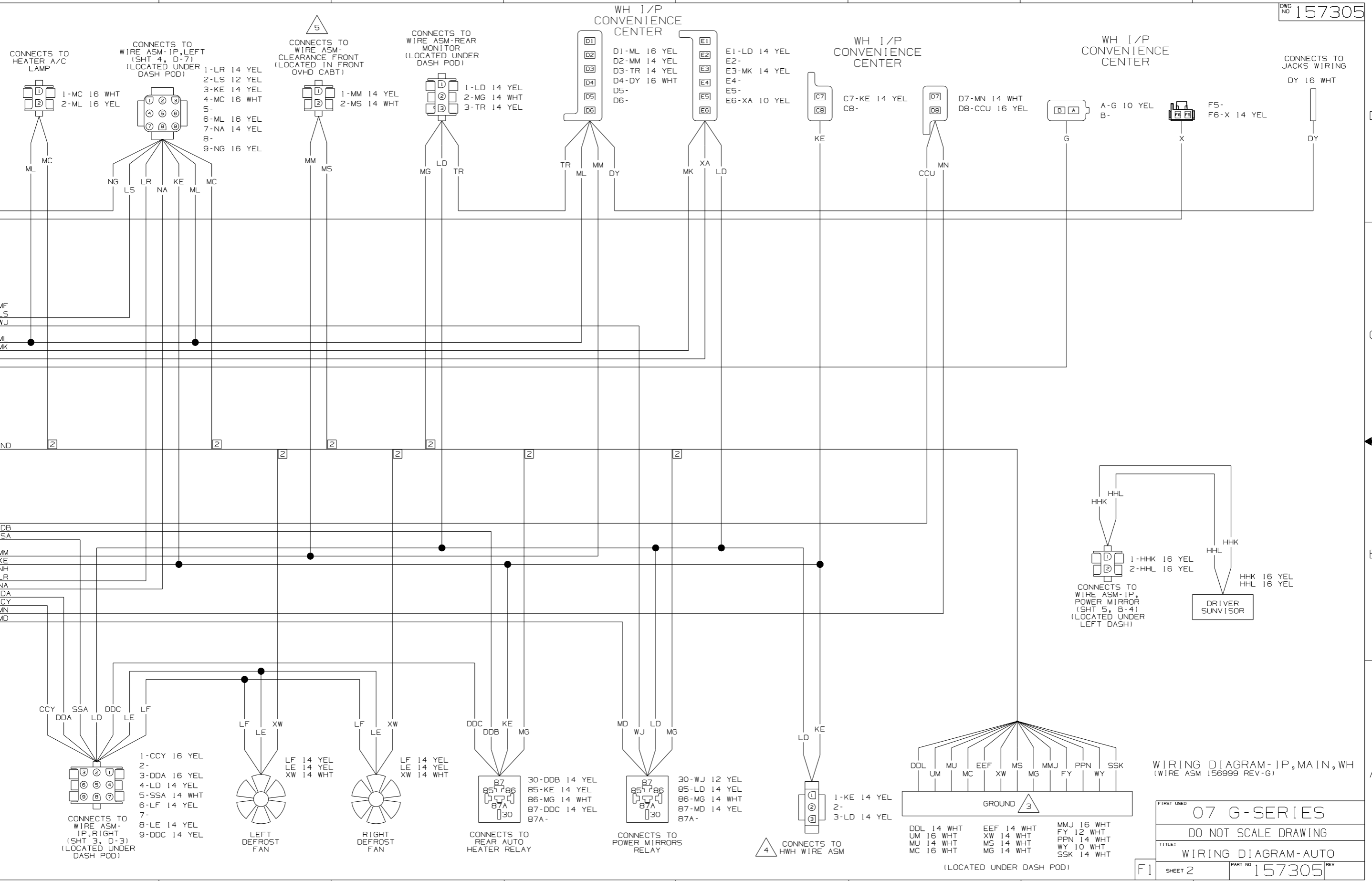

WIRING DIAGRAM-IP,MAIN,WH (WIRE ASM 156999 REV-G)

FIRST USED	07 G-SERIES	
TITLE	DO NOT SCALE DRAWING	
	WIRING DIAGRAM-AUTO	
SHEET 2	PART NO	157305
	REV	

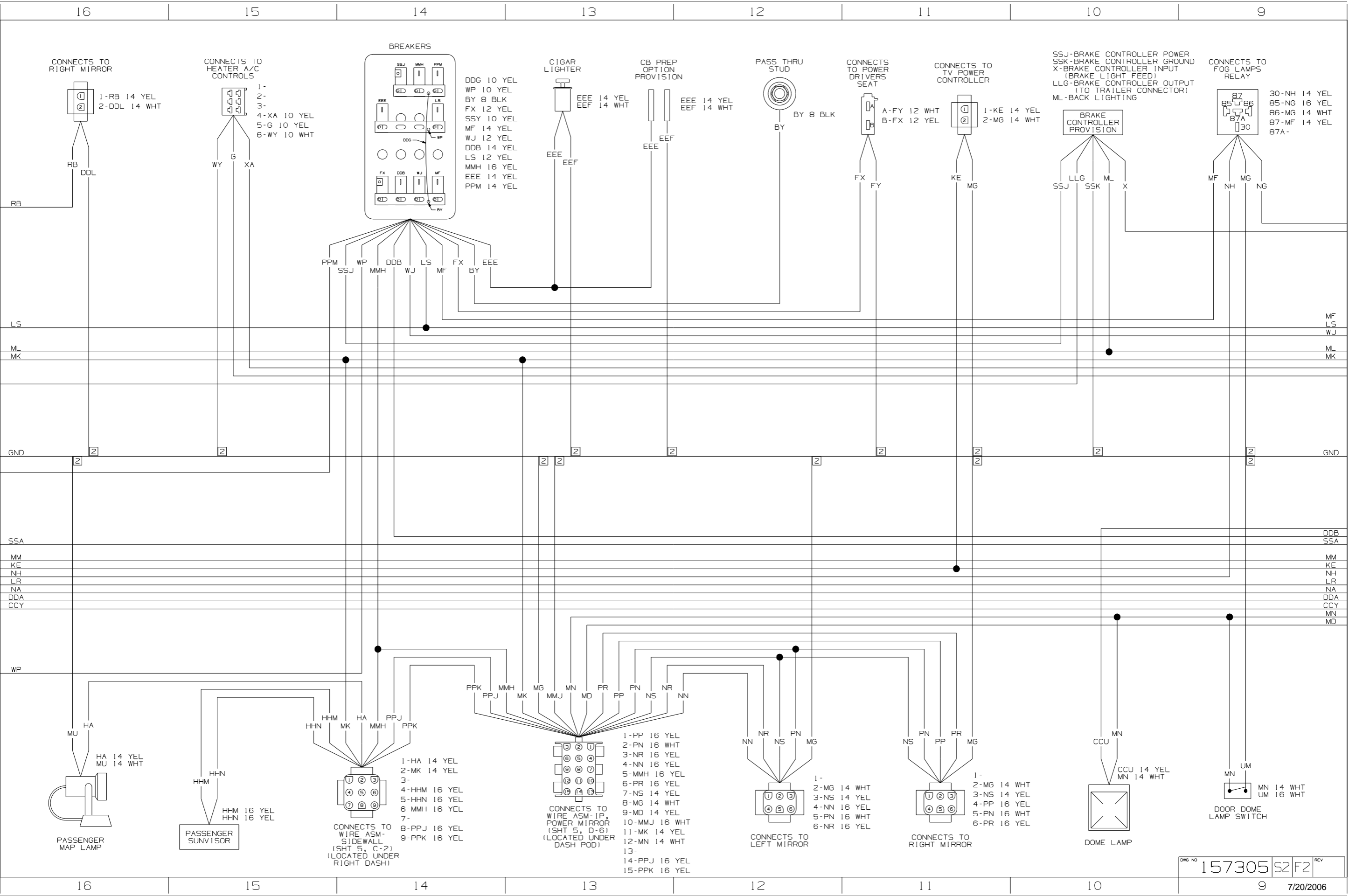

D
C
B
A

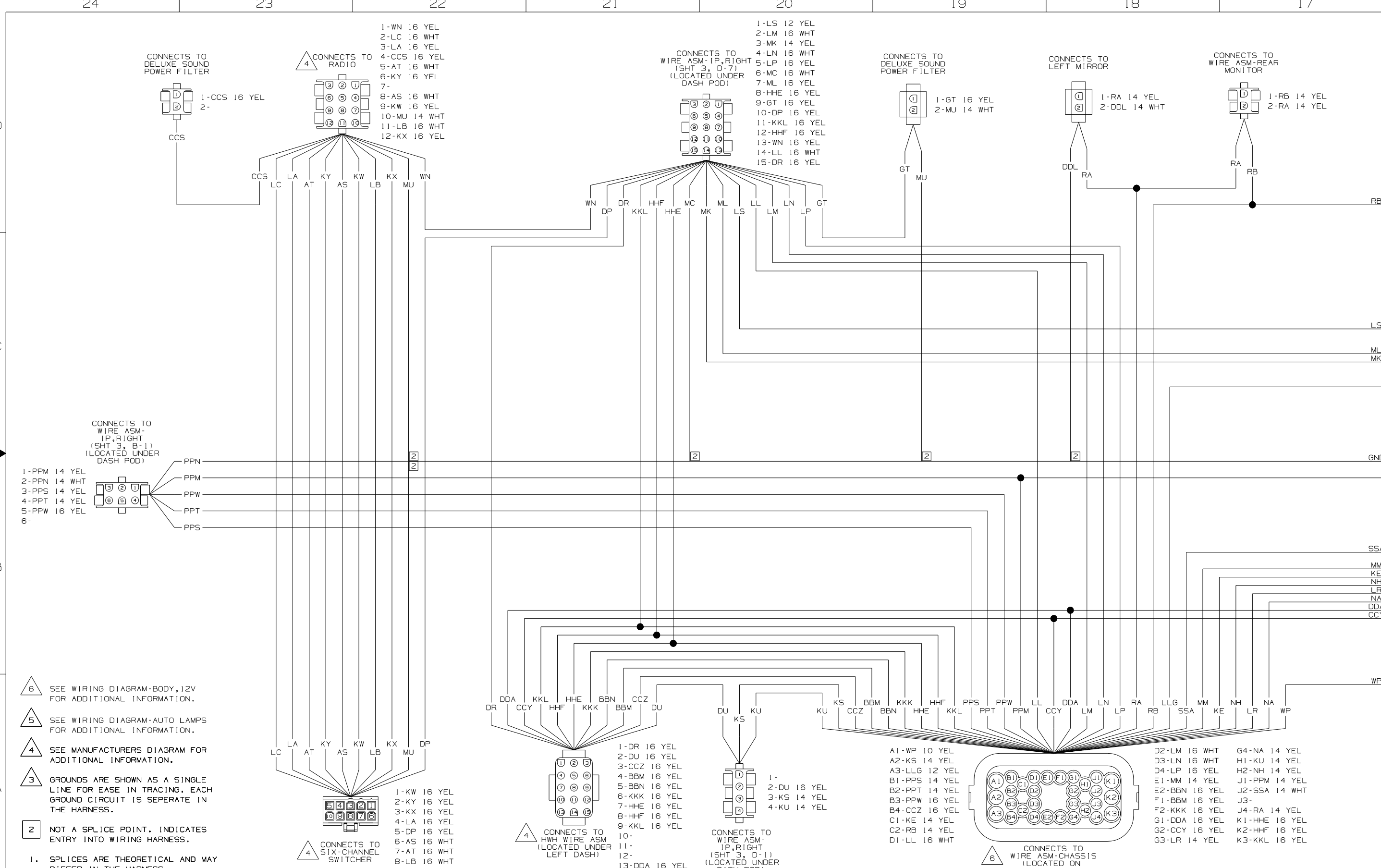

- 6 SEE WIRING DIAGRAM-BODY,12V FOR ADDITIONAL INFORMATION.
 - 5 SEE WIRING DIAGRAM-AUTO LAMPS FOR ADDITIONAL INFORMATION.
 - 4 SEE MANUFACTURERS DIAGRAM FOR ADDITIONAL INFORMATION.
 - 3 GROUNDS ARE SHOWN AS A SINGLE LINE FOR EASE IN TRACING. EACH GROUND CIRCUIT IS SEPERATE IN THE HARNESS.
 - 2 NOT A SPLICE POINT. INDICATES ENTRY INTO WIRING HARNESS.
- NOTES:
1. SPLICES ARE THEORETICAL AND MAY DIFFER IN THE HARNESS.

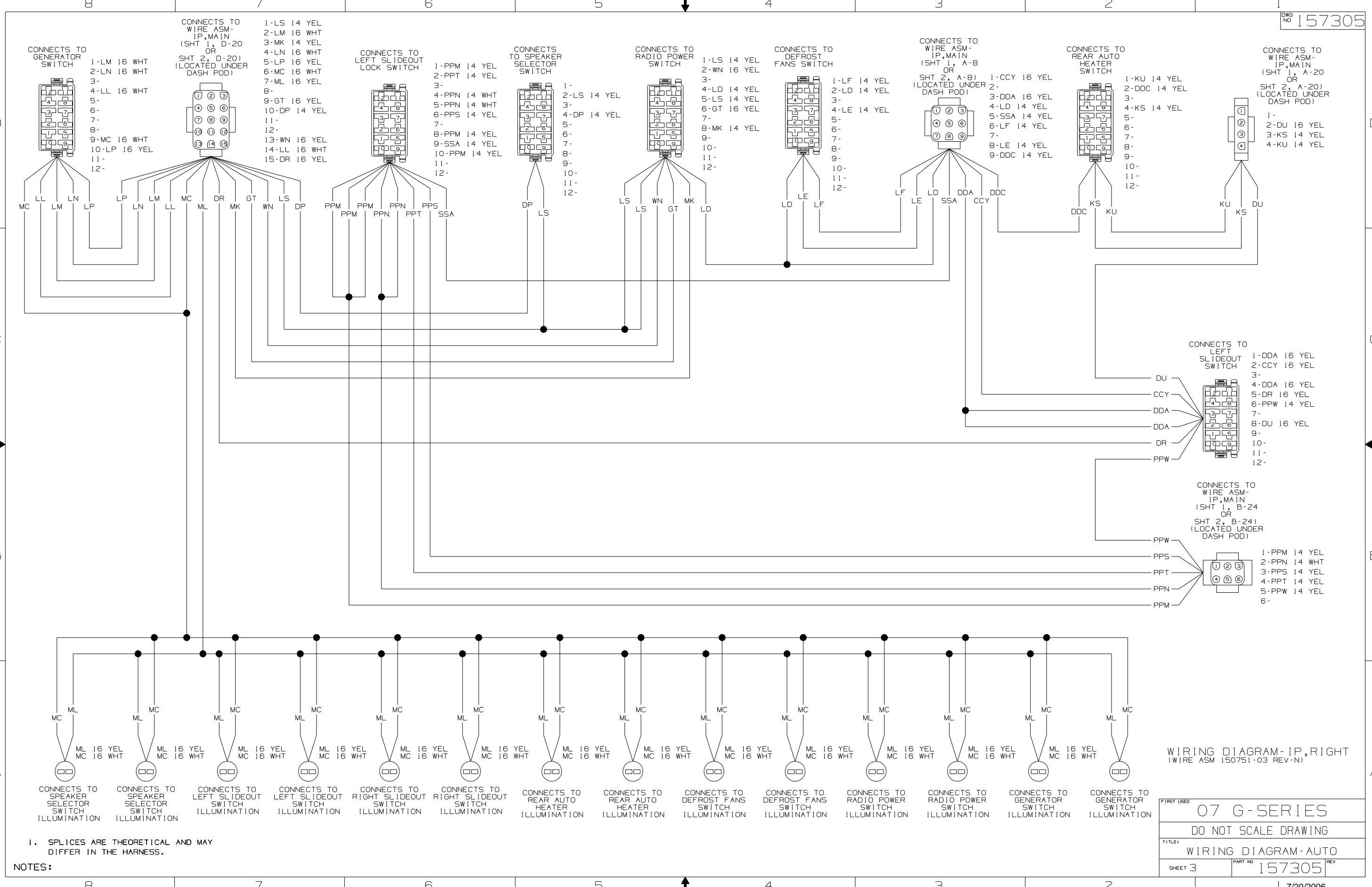

CONNECTS TO WIRE ASM-IP,MAIN (SHT 1, D-20) OR SHT 2, D-20) (LOCATED UNDER DASH POD)

- 1-LS 14 YEL
- 2-LM 16 WHT
- 3-MK 14 YEL
- 4-LN 16 WHT
- 5-LP 16 YEL
- 6-MC 16 WHT
- 7-ML 16 YEL
- 8-
- 9-GT 16 YEL
- 10-DP 14 YEL
- 11-
- 12-
- 13-WN 16 YEL
- 14-LL 16 WHT
- 15-DR 16 YEL

CONNECTS TO LEFT SLIDEOUT LOCK SWITCH

- 1-PPM 14 YEL
- 2-PPT 14 YEL
- 3-
- 4-PPN 14 WHT
- 5-PPN 14 WHT
- 6-PPS 14 YEL
- 7-
- 8-PPM 14 YEL
- 9-SSA 14 YEL
- 10-PPM 14 YEL
- 11-
- 12-

CONNECTS TO SPEAKER SELECTOR SWITCH

- 1-
- 2-LS 14 YEL
- 3-
- 4-DP 14 YEL
- 5-
- 6-
- 7-
- 8-
- 9-
- 10-
- 11-
- 12-

CONNECTS TO RADIO POWER SWITCH

- 1-LS 14 YEL
- 2-WN 16 YEL
- 3-
- 4-LD 14 YEL
- 5-LS 14 YEL
- 6-GT 16 YEL
- 7-
- 8-MK 14 YEL
- 9-
- 10-
- 11-
- 12-

CONNECTS TO DEFROST FANS SWITCH

- 1-LF 14 YEL
- 2-LD 14 YEL
- 3-
- 4-LE 14 YEL
- 5-
- 6-
- 7-
- 8-
- 9-
- 10-
- 11-
- 12-

CONNECTS TO WIRE ASM-IP,MAIN (SHT 1, A-8) OR SHT 2, A-8) (LOCATED UNDER DASH POD)

- 1-CCY 16 YEL
- 2-
- 3-DDA 16 YEL
- 4-LD 14 YEL
- 5-SSA 14 YEL
- 6-LF 14 YEL
- 7-
- 8-LE 14 YEL
- 9-DDC 14 YEL

CONNECTS TO REAR AUTO HEATER SWITCH

- 1-KU 14 YEL
- 2-DDC 14 YEL
- 3-
- 4-KS 14 YEL
- 5-
- 6-
- 7-
- 8-
- 9-
- 10-
- 11-
- 12-

CONNECTS TO WIRE ASM-IP,MAIN (SHT 1, A-20) OR SHT 2, A-20) (LOCATED UNDER DASH POD)

- 1-
- 2-DU 16 YEL
- 3-KS 14 YEL
- 4-KU 14 YEL

CONNECTS TO LEFT SLIDEOUT SWITCH

- 1-DDA 16 YEL
- 2-CCY 16 YEL
- 3-
- 4-DDA 16 YEL
- 5-DR 16 YEL
- 6-PPW 14 YEL
- 7-
- 8-DU 16 YEL
- 9-
- 10-
- 11-
- 12-

CONNECTS TO WIRE ASM-IP,MAIN (SHT 1, B-24) OR SHT 2, B-24) (LOCATED UNDER DASH POD)

- 1-PPM 14 YEL
- 2-PPN 14 WHT
- 3-PPS 14 YEL
- 4-PPT 14 YEL
- 5-PPM 14 YEL
- 6-

WIRING DIAGRAM-IP,RIGHT (WIRE ASM 150751-03 REV-N)

NOTES:
1. SPLICES ARE THEORETICAL AND MAY DIFFER IN THE HARNESS.

FIRST USED	07 G-SERIES		
TITLE:	DO NOT SCALE DRAWING		
	WIRING DIAGRAM-AUTO		
SHEET 3	PART NO	157305	REV

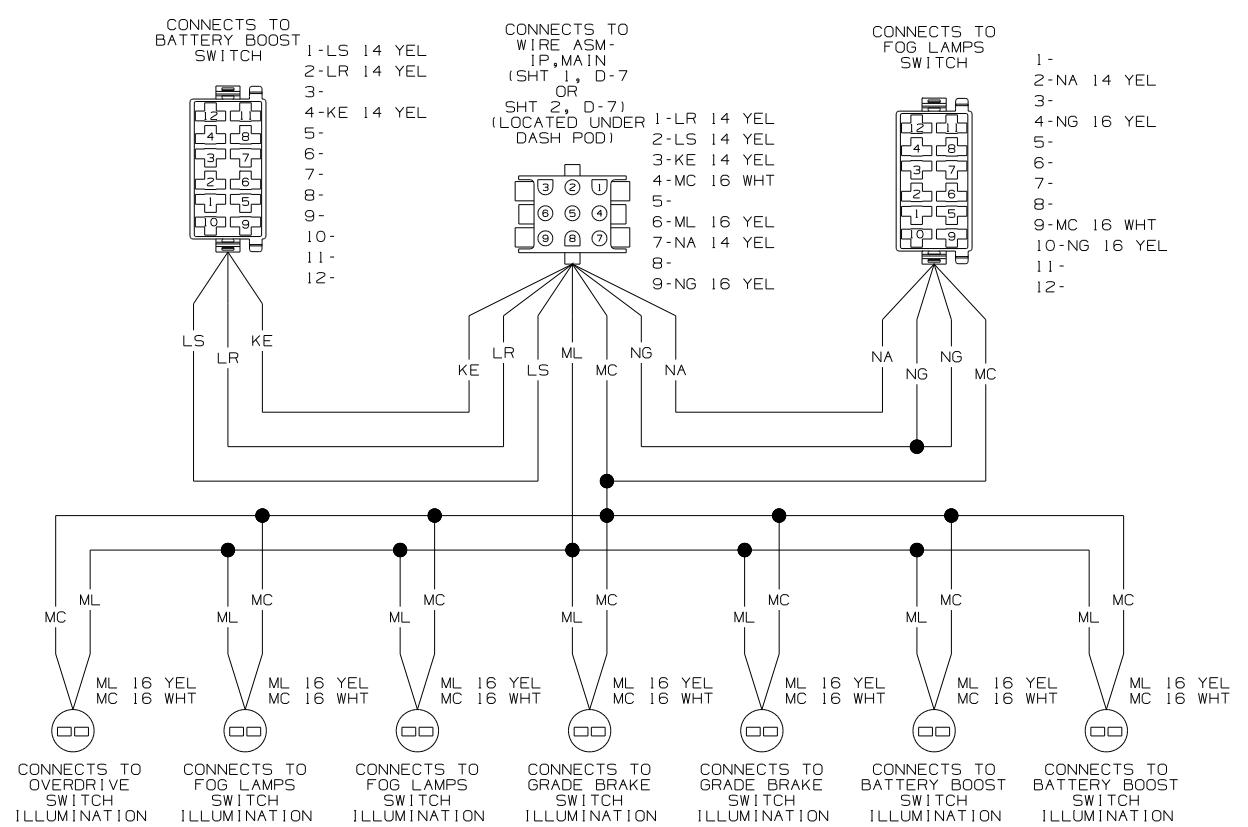

WIRING DIAGRAM-IP, LEFT
(WIRE ASM 150752-02 REV-G)

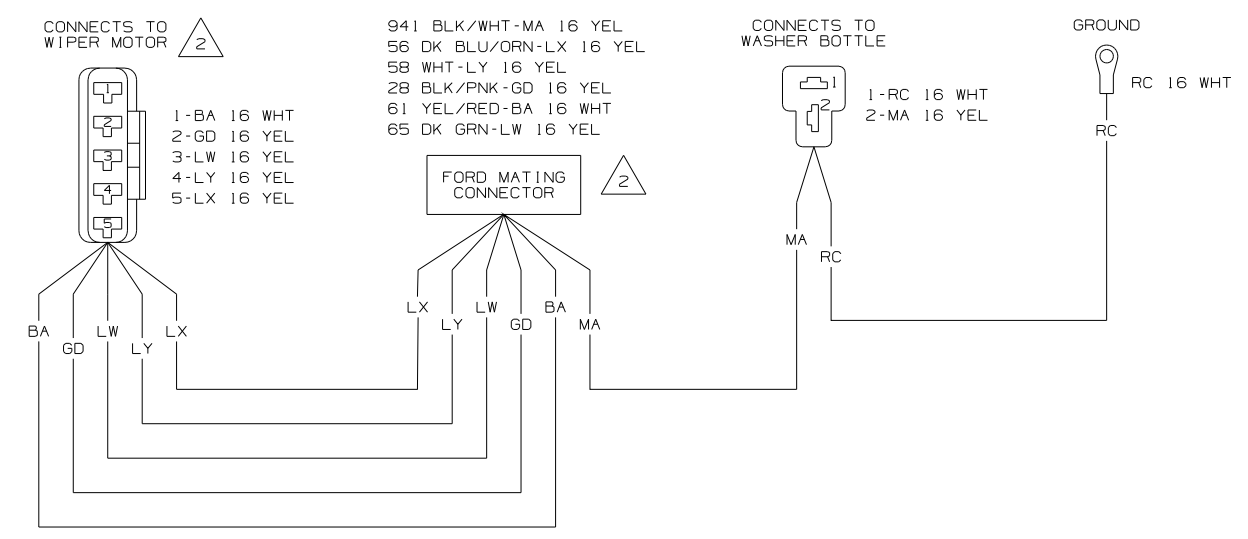

WIRING DIAGRAM-WIPER/WASHER
(WIRE ASM 111096-03 REV-F)

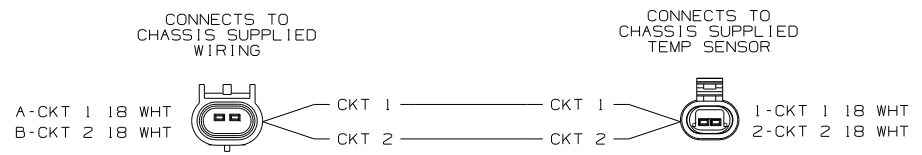

WIRING DIAGRAM-TEMP, SENSOR
(WIRE ASM 147313 REV-C)

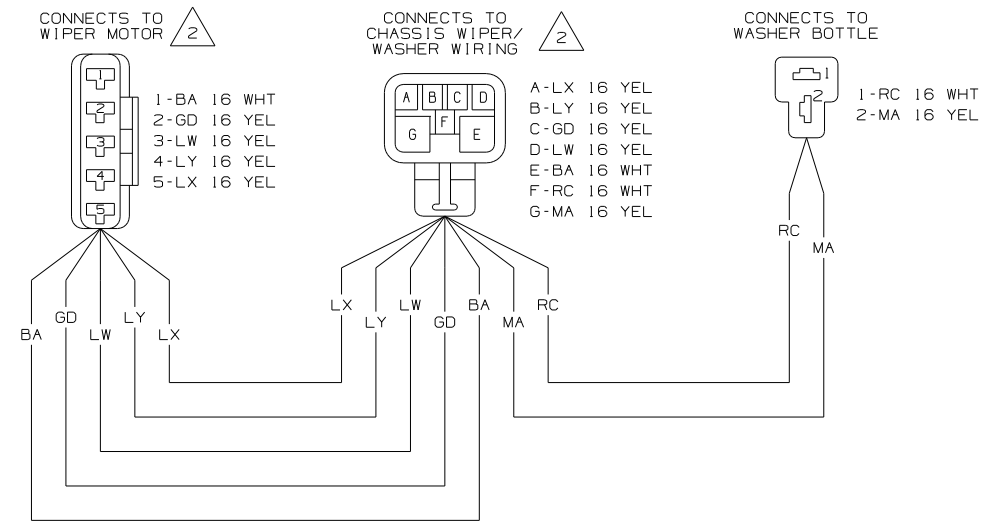

WIRING DIAGRAM-WIPER/WASHER
(WIRE ASM 126030 REV-E)

SEE MANUFACTURERS DIAGRAM FOR ADDITIONAL INFORMATION.

1. SPLICES ARE THEORETICAL AND MAY DIFFER IN THE HARNESS.

NOTES:

FIRST USED	07 G-SERIES	
TITLE	DO NOT SCALE DRAWING	
SHEET 4	PART NO	157305
	REV	

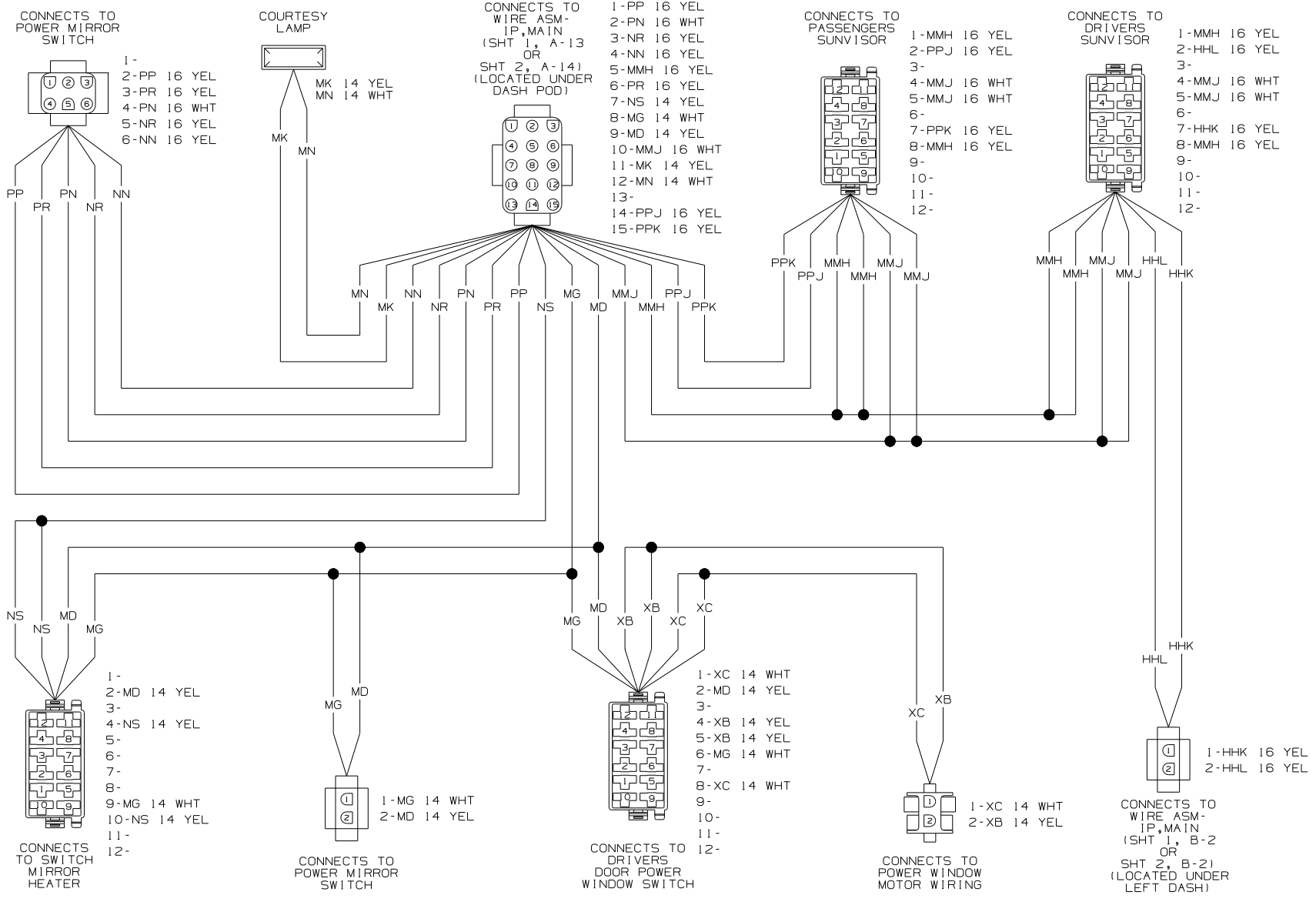

WIRING DIAGRAM-IP, POWER MIRROR (WIRE ASM 129436-11 REV-A6)

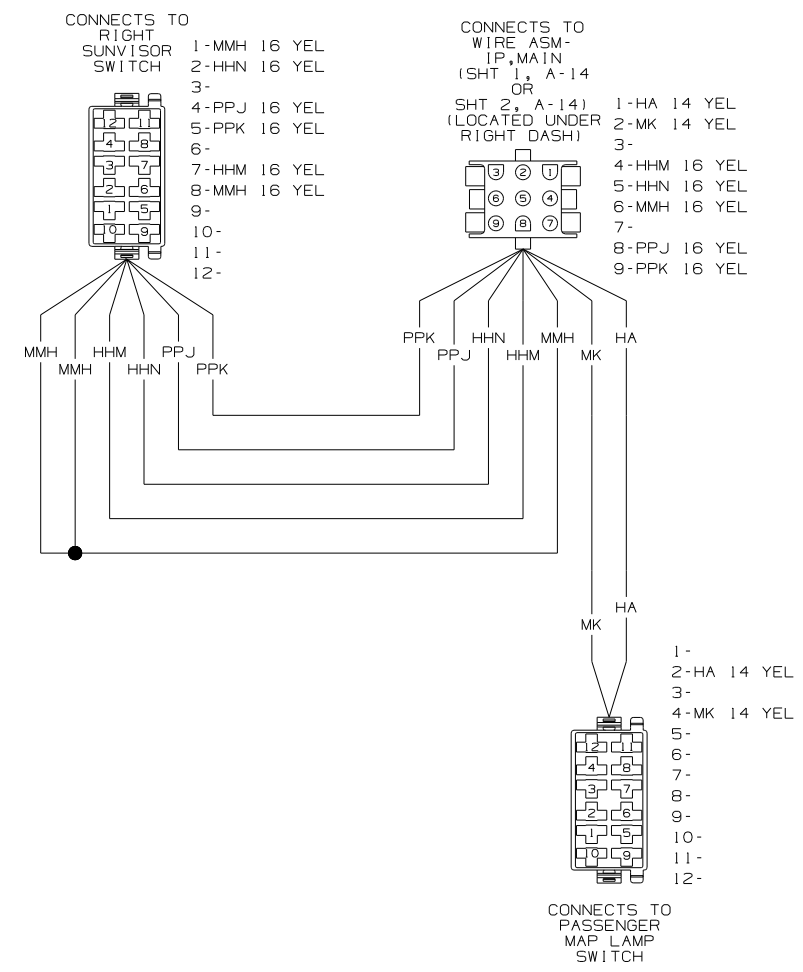

WIRING DIAGRAM-SIDEWALL (WIRE ASM 149199-02 REV-F)

1. SPLICES ARE THEORETICAL AND MAY DIFFER IN THE HARNESS.

NOTES:

FIRST USED	07 G-SERIES		
TITLE:	DO NOT SCALE DRAWING		
	WIRING DIAGRAM-AUTO		
SHEET 5	PART NO	157305	REV