



DANGER

Danger of electrical shock, burns or death. Always remove all power sources before attempting any repair, service or diagnostic work. Power can be present from shore power, generator, inverter or battery. All power sources must be disabled and secured before performing any service.



CAUTION

If you lack the skills, tools or equipment to perform diagnostic or repair work leave such work to an authorized Winnebago Industries dealer or other qualified shop.

CHASSIS GROUND

- PA 14 WHT
- JN 14 WHT
- EED 12 WHT
- MP 16 WHT
- MP-1 18 WX
- WE 14 WHT
- FM 14 WHT
- MS 16 WHT

- CONNECTS TO WIRE ASM SIDEWALL (SHT 5, B-3) LOCATED BEHIND SOFA
- 1-DJ 16 YEL
 - 2-DK 16 WHT
 - 3-JG 14 YEL
 - 4-JN 14 WHT
 - 5-MM 14 YEL
 - 6-MS 16 WHT

- CONNECTS TO WIRE ASM ELECTRICAL BOX (SHT 6, C-4) LOCATED IN STEP BOX
- 1- 9-WH 14 Y
 - 2- 10-KE 14 YEL
 - 3-ER 16 YEL
 - 4- 11-LH 16 YEL
 - 5-LG 16 YEL
 - 6-FM 14 WHT
 - 7-LR 14 YEL
 - 8-HS 16 YEL
 - 13-LJ 16 YEL
 - 14-FFD 12 YEL
 - 15-KA 12 YEL

- CONNECTS TO CHASSIS WIRING
- 1-LJ 16 YEL
 - 2-FM 14 WHT

FFD

MM

LR

DY

GNDS

- LG
- ER
- HS
- JG
- DJ
- DK
- LH
- LJ
- DY
- MM
- NW
- WH
- ES
- JT

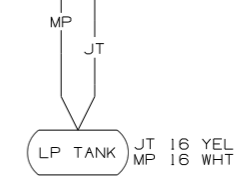
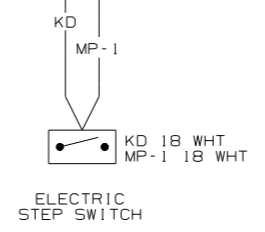
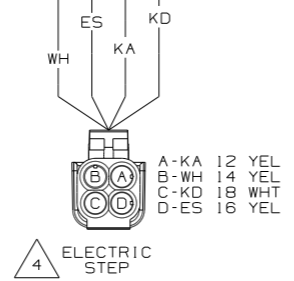
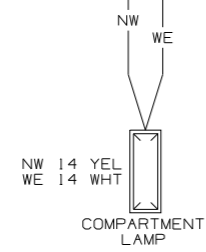
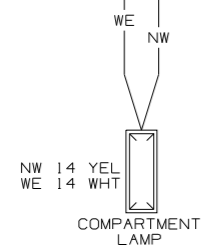
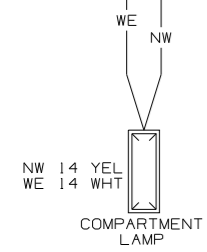

WIRING DIAGRAM-CHASSIS (WIRE ASM-159264 REV B)

		COPYRIGHT 2006 WINNEBAGO INDUSTRIES, INC.
DFTR	ORIG. DATE	
CHRR	ALL DIMENSIONS ARE IN MILLIMETERS	
P.E.		
M.E.	FIRST USED	07 F35A
DSNR		
UNSPECIFIED TOLERANCES ARE:		MATERIAL:
WHOLE DIM (XX)	:	
ONE-PLACE (X.X)	:	
TWO-PLACE (X.XX)	:	
ANGLE	:	
THIRD ANGLE PROJECTION		
DO NOT SCALE DRAWING		
TITLE: WIRING DIAGRAM-BODY, 12V		
SHEET 1 of 7	PART NO	159098
REV		

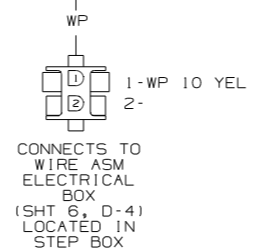
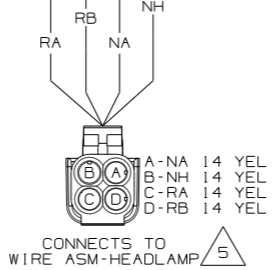
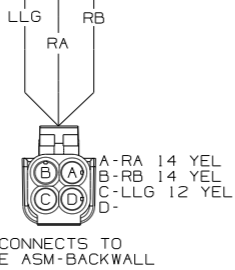
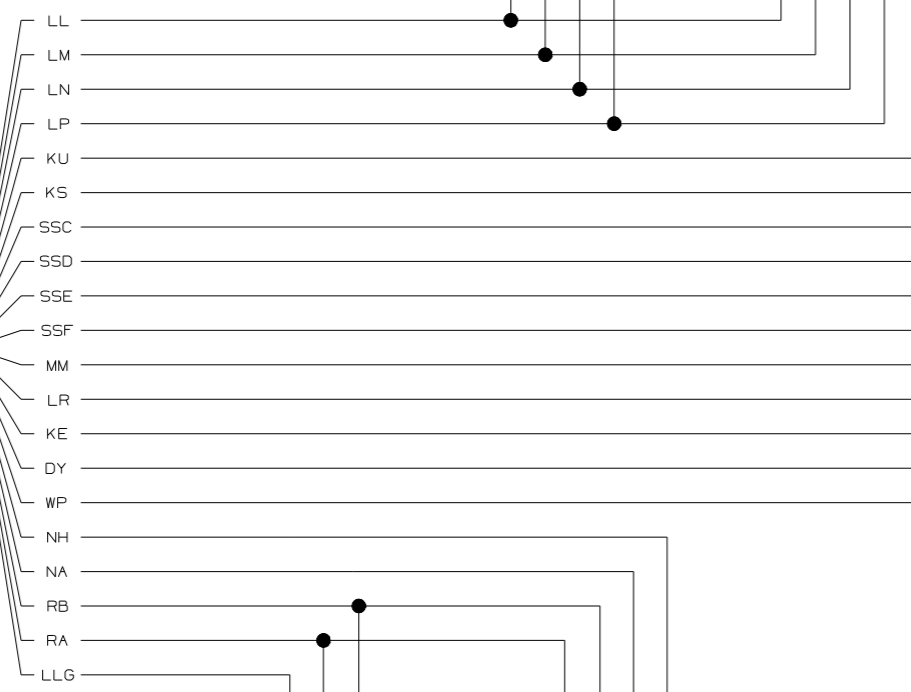
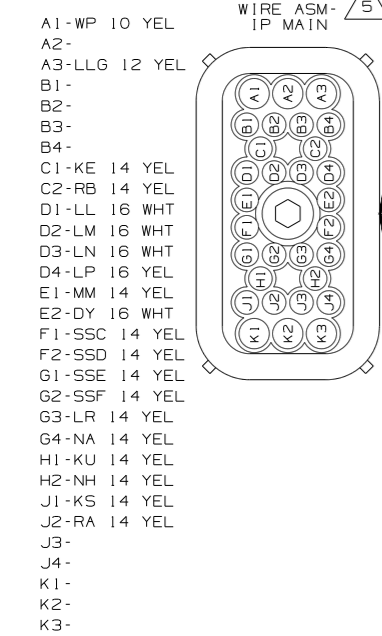
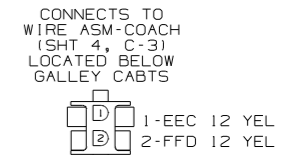
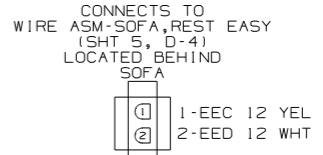
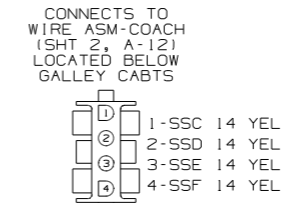
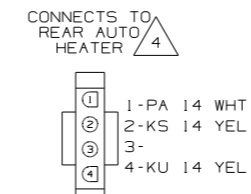
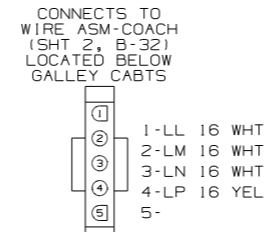
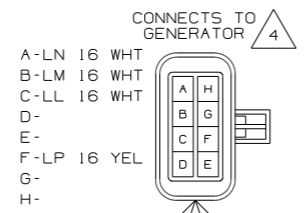
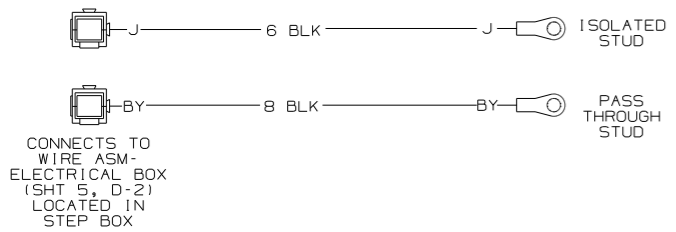

- 6 USED FOR MANUFACTURING
- 5 SEE WIRING DIAGRAM-AUTO FOR ADDITIONAL INFORMATION.
- 4 SEE MANUFACTURERS DIAGRAM FOR ADDITIONAL INFORMATION.
- 3 GROUNDS ARE SHOWN AS A SINGLE LINE FOR EASE IN TRACING. EACH GROUND CIRCUIT IS SEPERATE IN THE HARNESS.
- 2 NOT A SPLICE POINT. INDICATES ENTRY INTO WIRING HARNESS.
- NOTES:
1. SPLICES ARE THEORETICAL AND MAY DIFFER IN THE HARNESS.

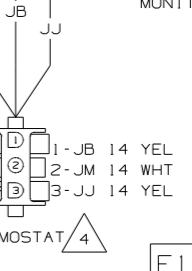
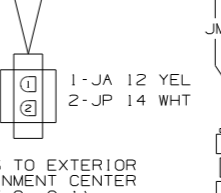
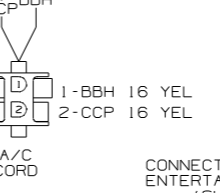
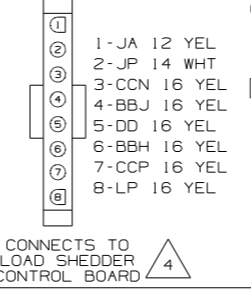
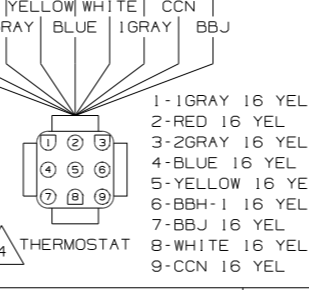
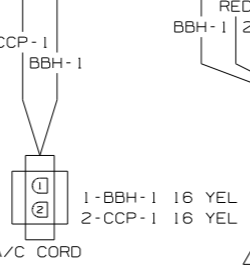
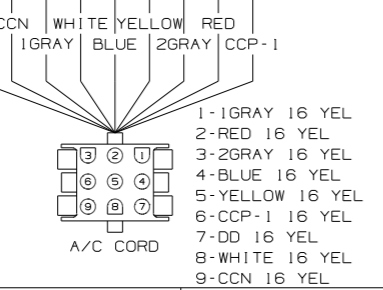
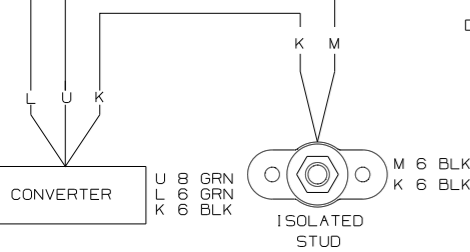
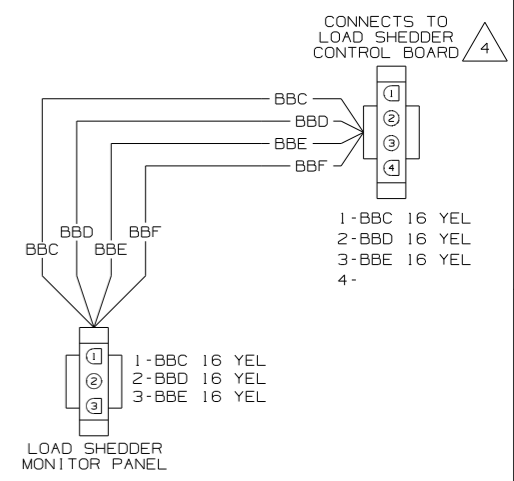
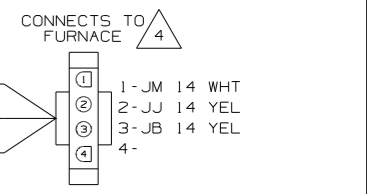
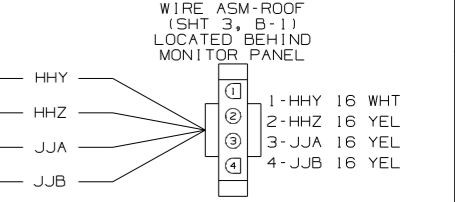
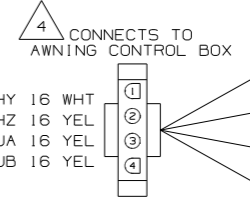
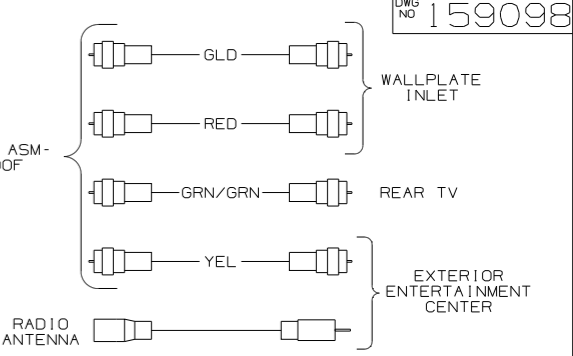
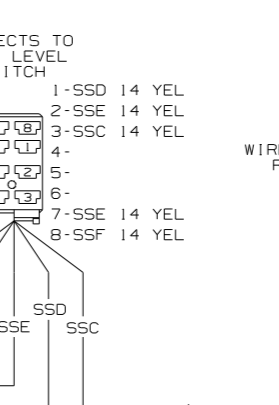
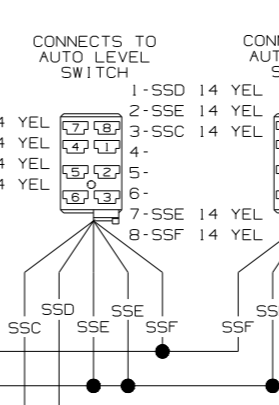
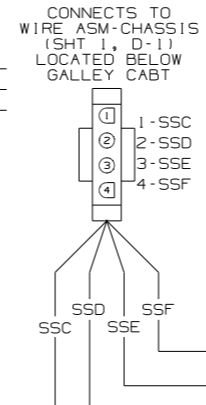
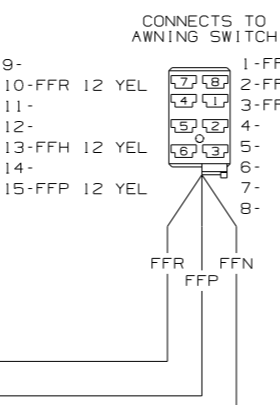
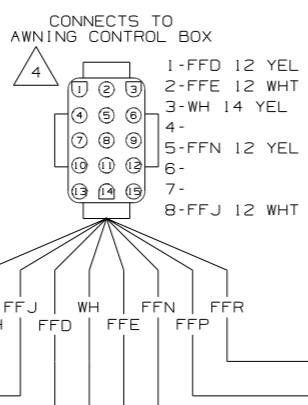
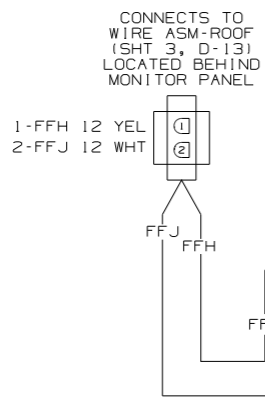
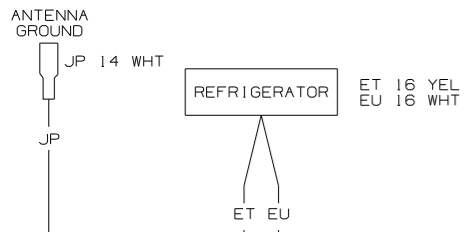
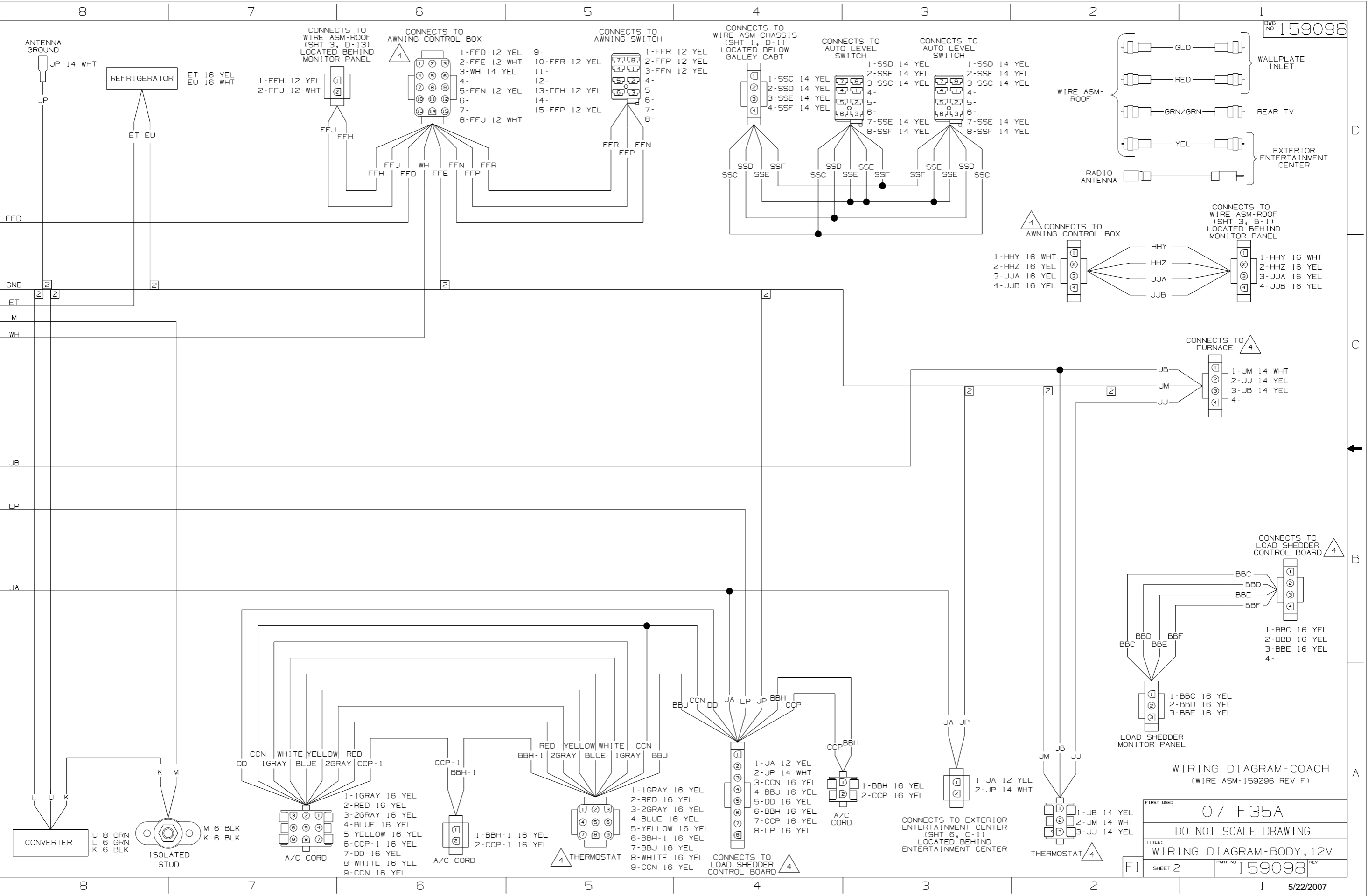

WIRING DIAGRAM-COACH (WIRE ASM-159296 REV F)

FIRST USED	07 F35A
DO NOT SCALE DRAWING	
TITLE:	WIRING DIAGRAM-BODY, 12V
SHEET 2	PART NO 159098

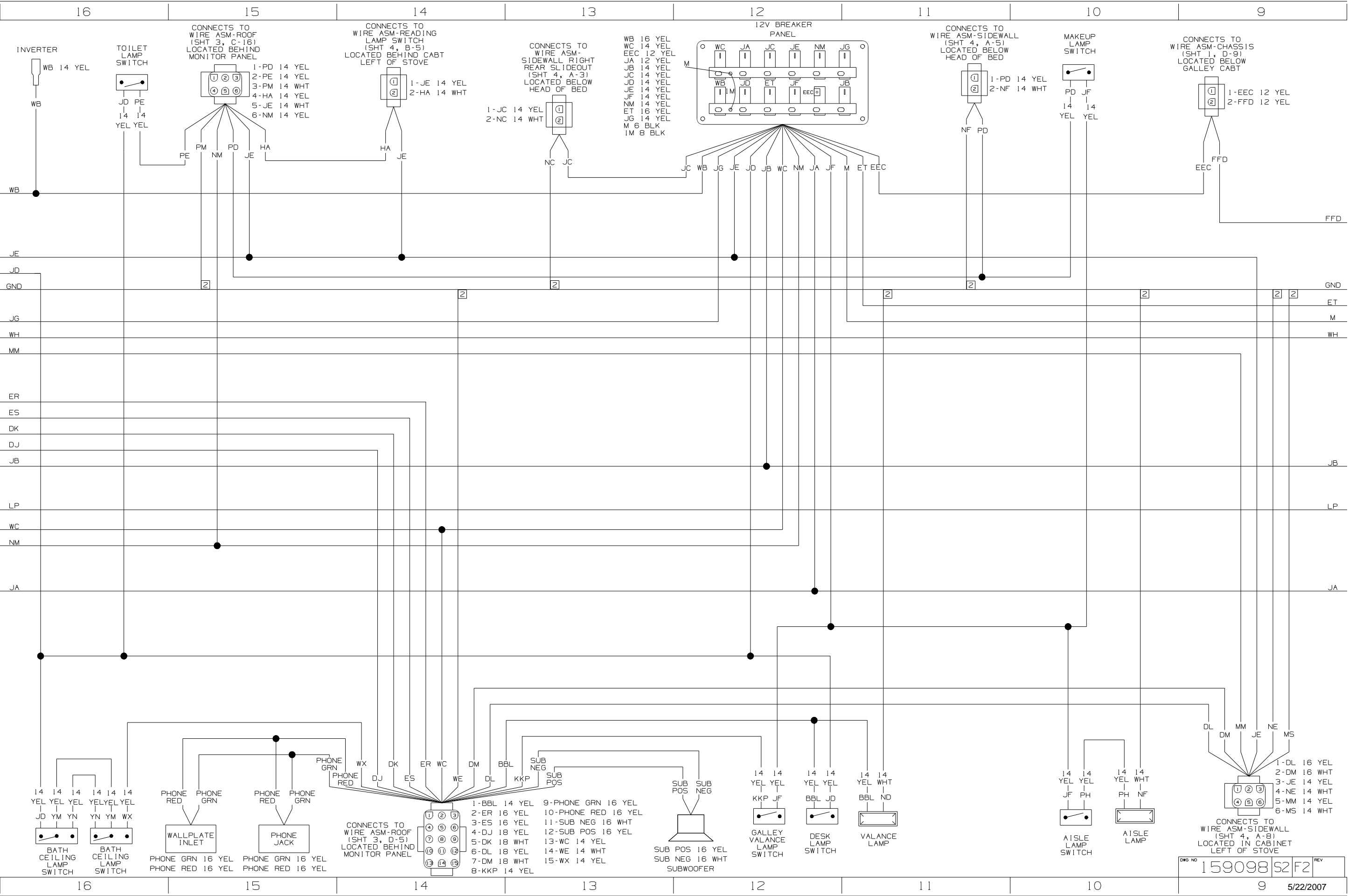

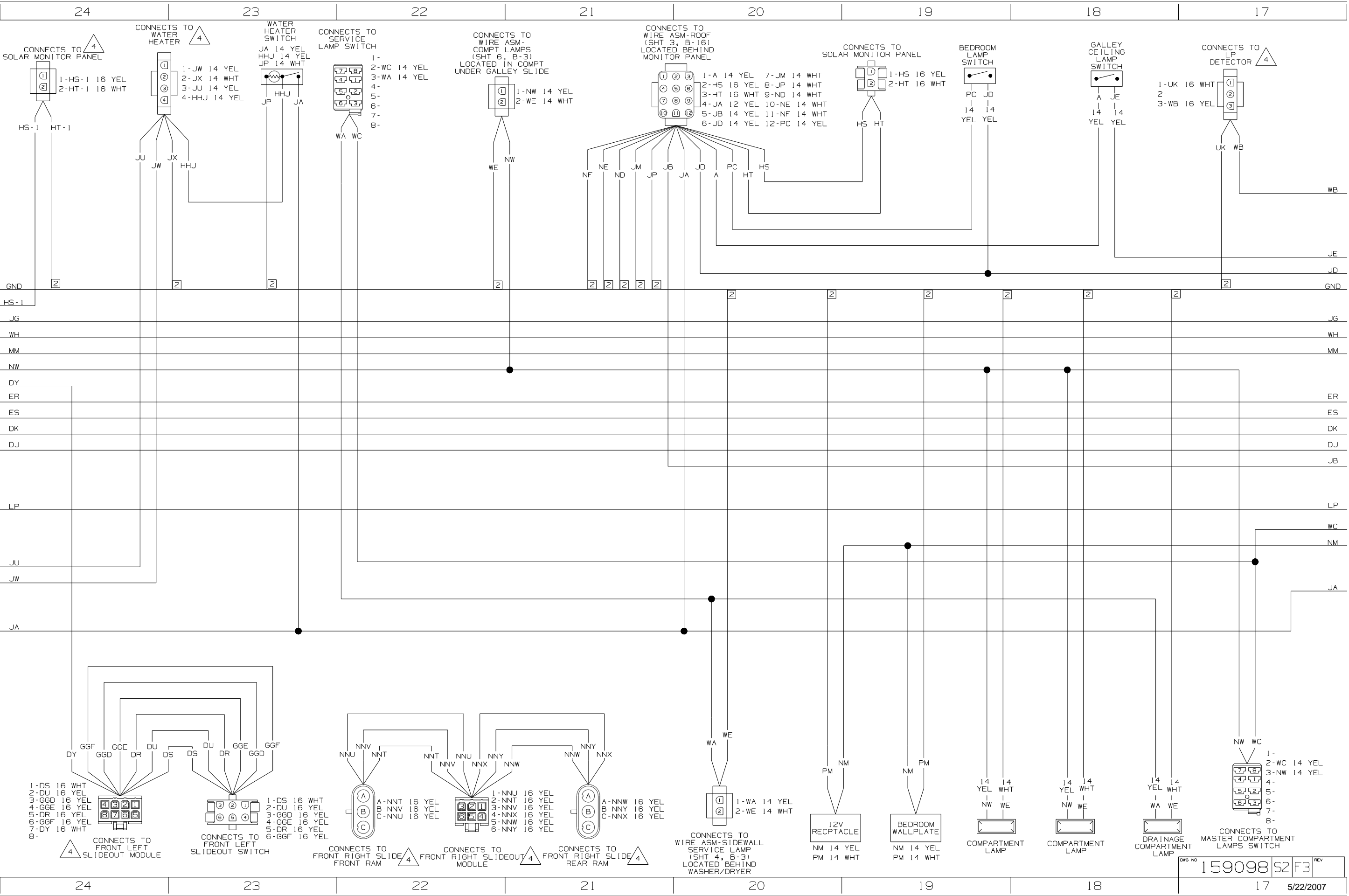

CONNECTS TO SOLAR MONITOR PANEL

1-HS-1 16 YEL
2-HT-1 16 WHT

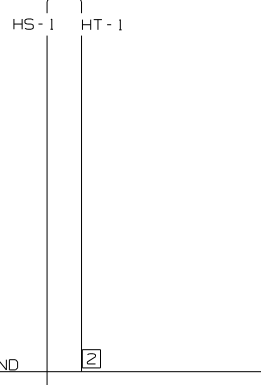

CONNECTS TO WATER HEATER

1-JW 14 YEL
2-JX 14 WHT
3-JU 14 YEL
4-HHJ 14 YEL

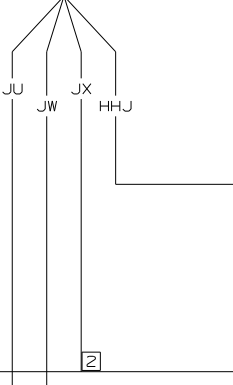

WATER HEATER SWITCH

JA 14 YEL
HHJ 14 YEL
JP 14 WHT

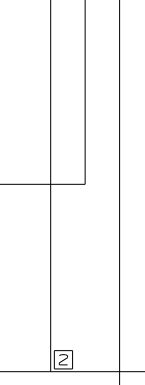

CONNECTS TO SERVICE LAMP SWITCH

1- 2-WC 14 YEL
2- 3-WA 14 YEL
3- 4-
4- 5-
5- 6-
6- 7-
7- 8-
8- WA WC

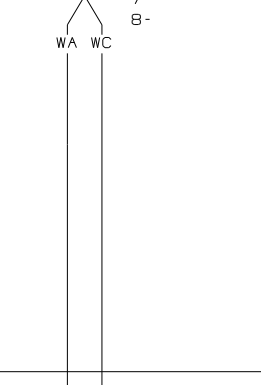

CONNECTS TO WIRE ASM-ROOF (SHT 3, B-16) LOCATED BEHIND MONITOR PANEL

1-NW 14 YEL
2-WE 14 WHT

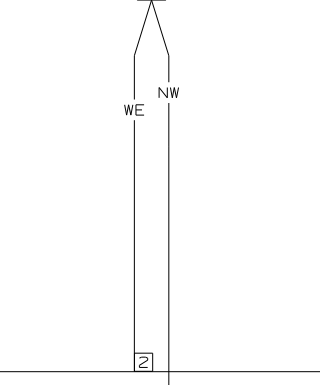

CONNECTS TO WIRE ASM-ROOF (SHT 3, B-16) LOCATED BEHIND MONITOR PANEL

1-A 14 YEL 7-JM 14 WHT
2-HS 16 YEL 8-JP 14 WHT
3-HT 16 WHT 9-ND 14 WHT
4-JA 12 YEL 10-NE 14 WHT
5-JB 14 YEL 11-NF 14 WHT
6-JD 14 YEL 12-PC 14 YEL

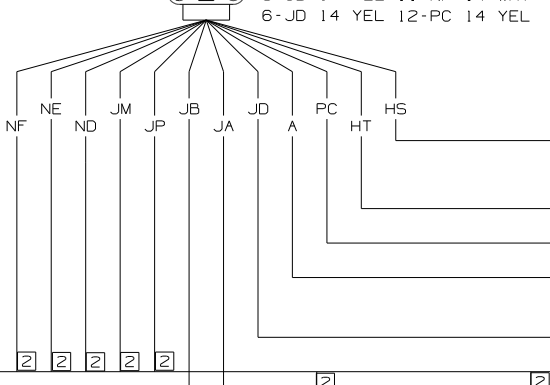

CONNECTS TO SOLAR MONITOR PANEL

1-HS 16 YEL
2-HT 16 WHT

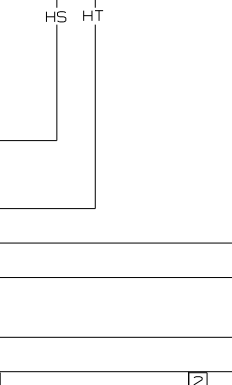

BEDROOM LAMP SWITCH

PC JD 14 14 YEL YEL

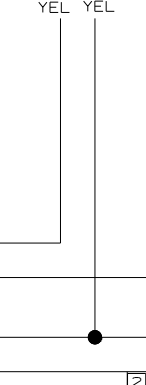

GALLEY CEILING LAMP SWITCH

A JE 14 14 YEL YEL

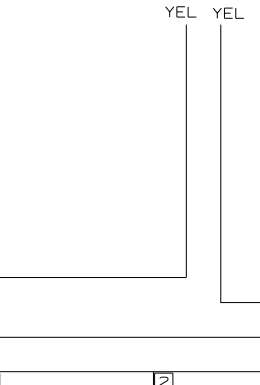

CONNECTS TO LP DETECTOR

1-UK 16 WHT
2- 3-WB 16 YEL

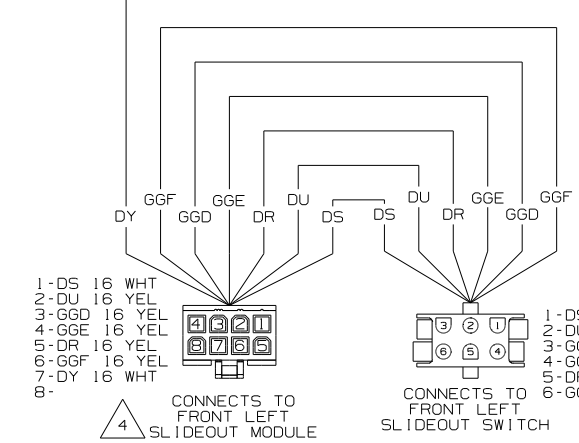
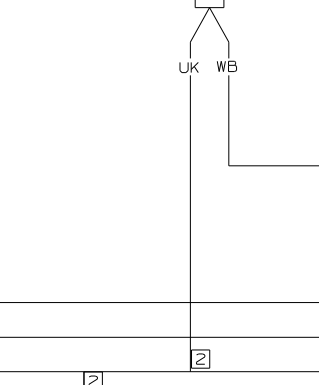

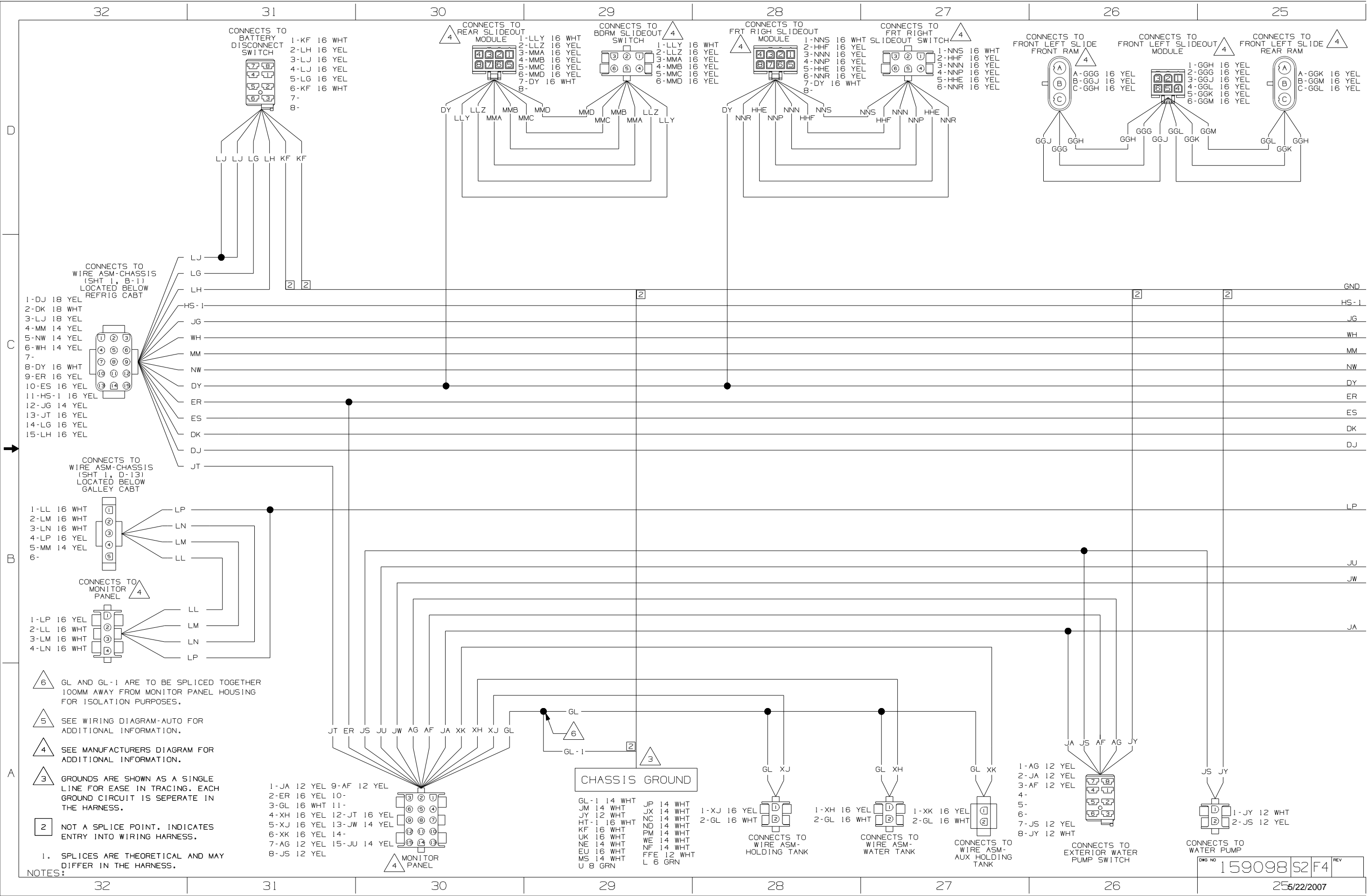

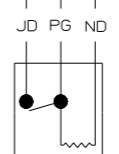
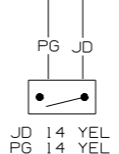
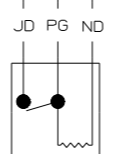
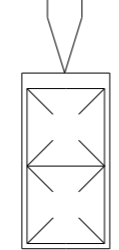
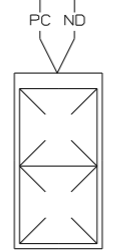
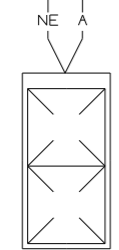
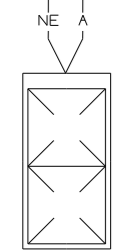
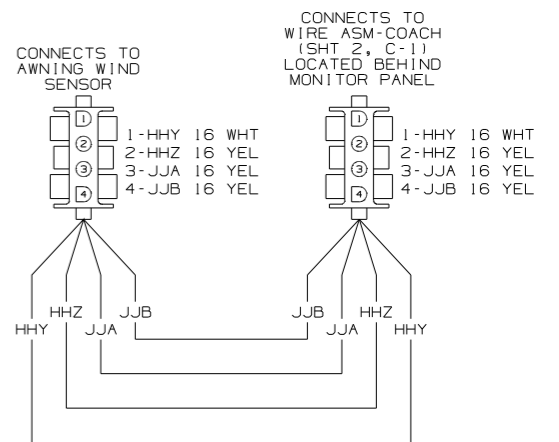
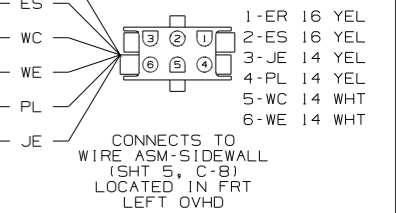
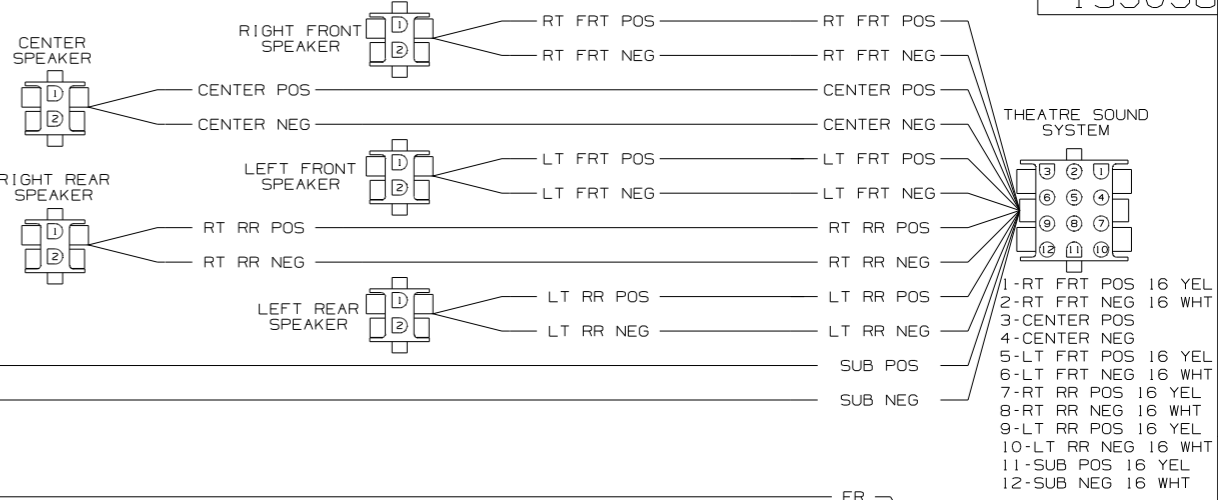
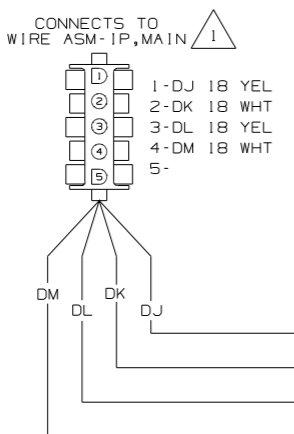
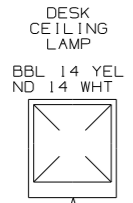
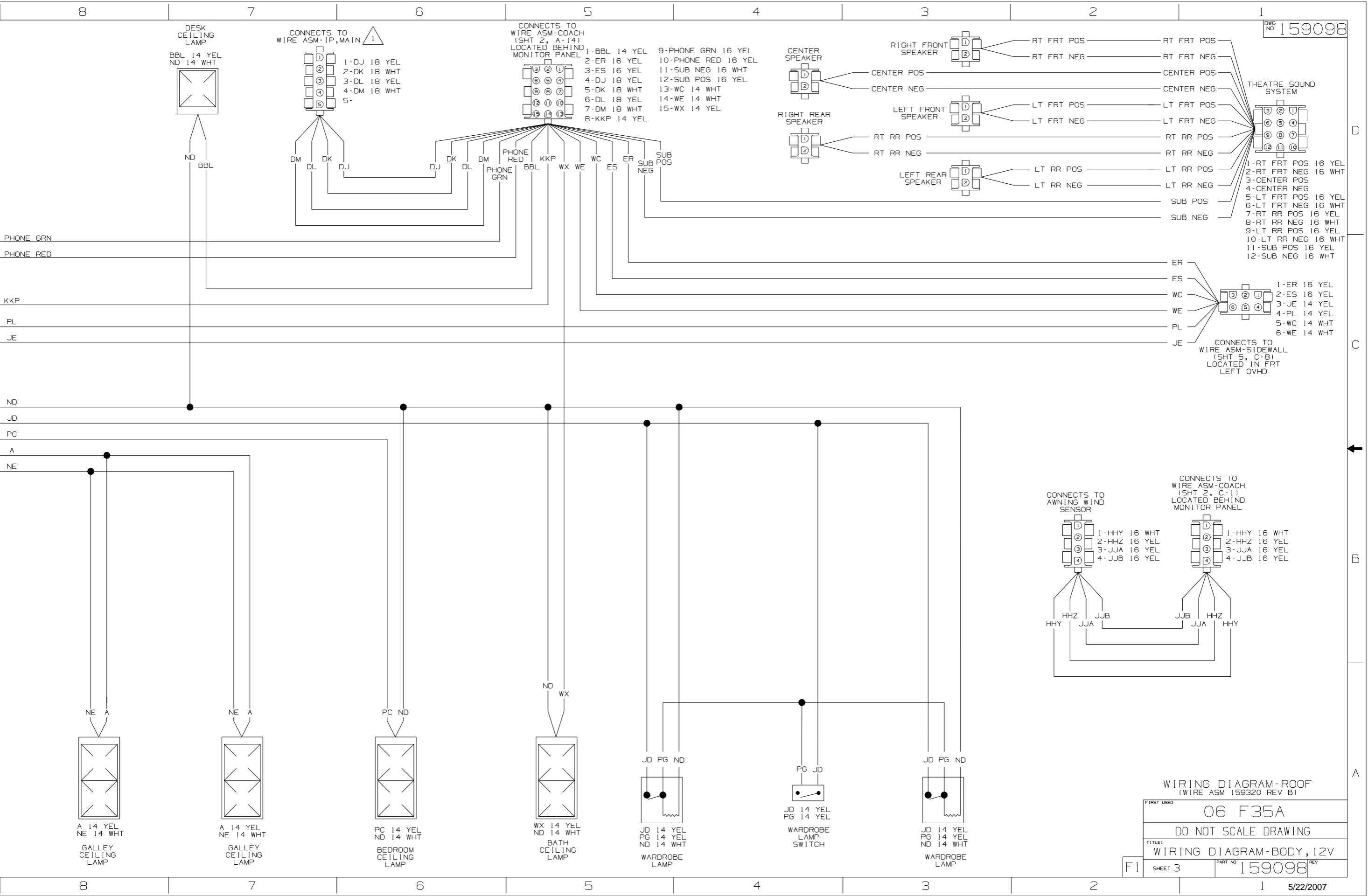

WIRING DIAGRAM-ROOF (WIRE ASM 159320 REV B)

FIRST USED	06 F35A
TITLE	DO NOT SCALE DRAWING
TITLE	WIRING DIAGRAM-BODY, 12V
SHEET 3	PART NO 159098

REV

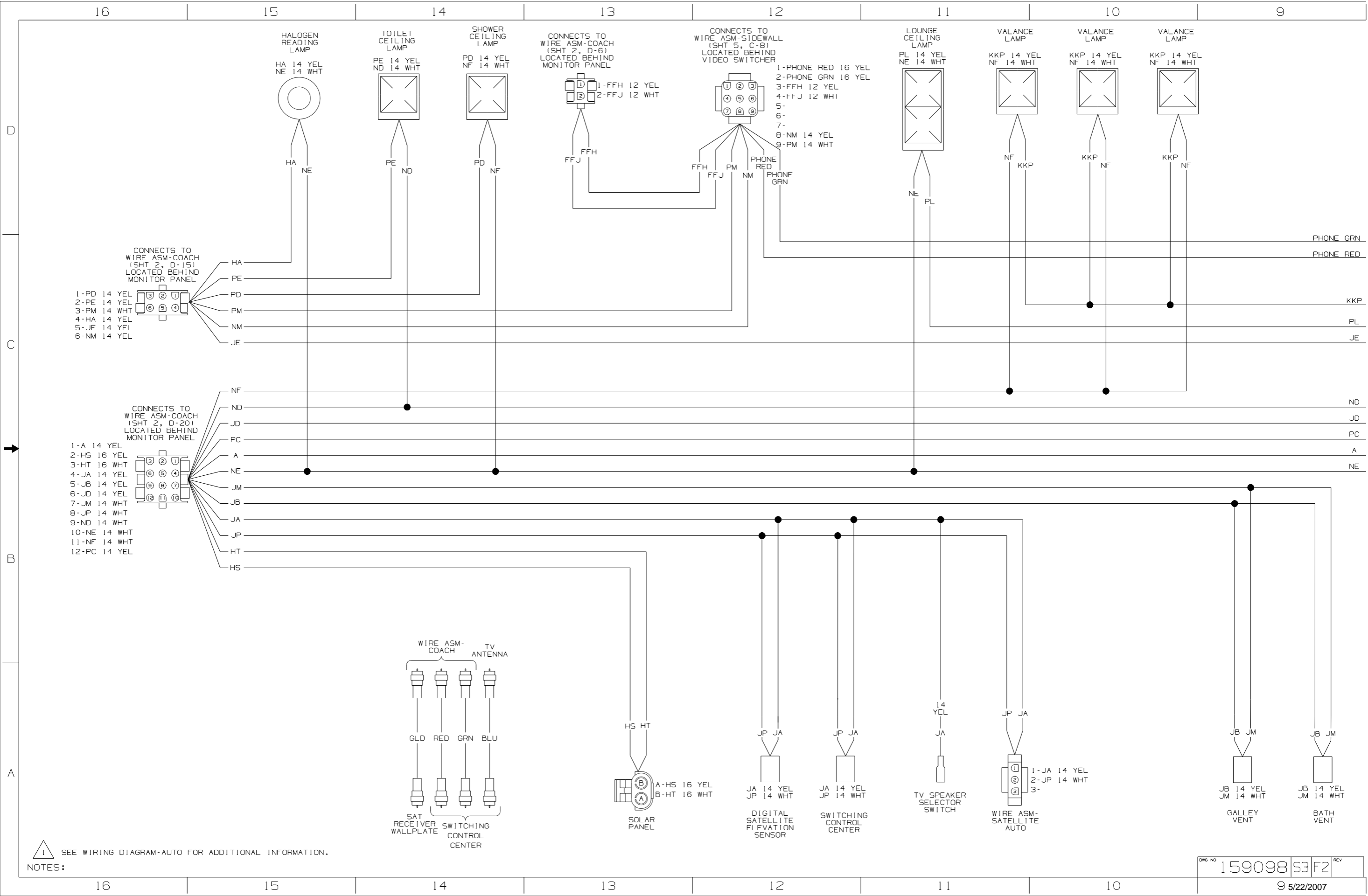

NOTES: SEE WIRING DIAGRAM-AUTO FOR ADDITIONAL INFORMATION.

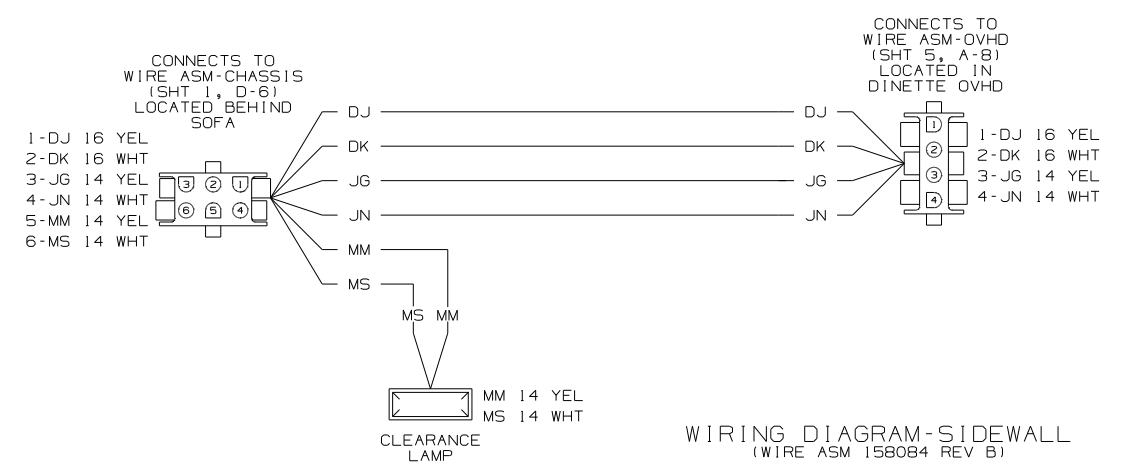
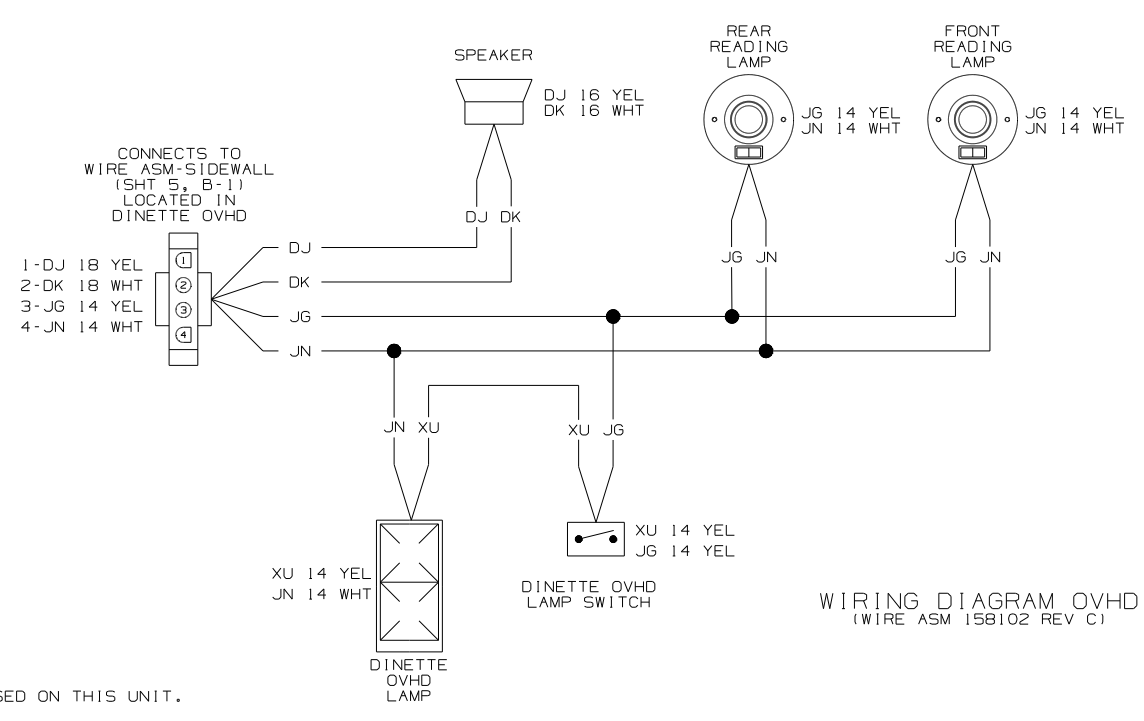
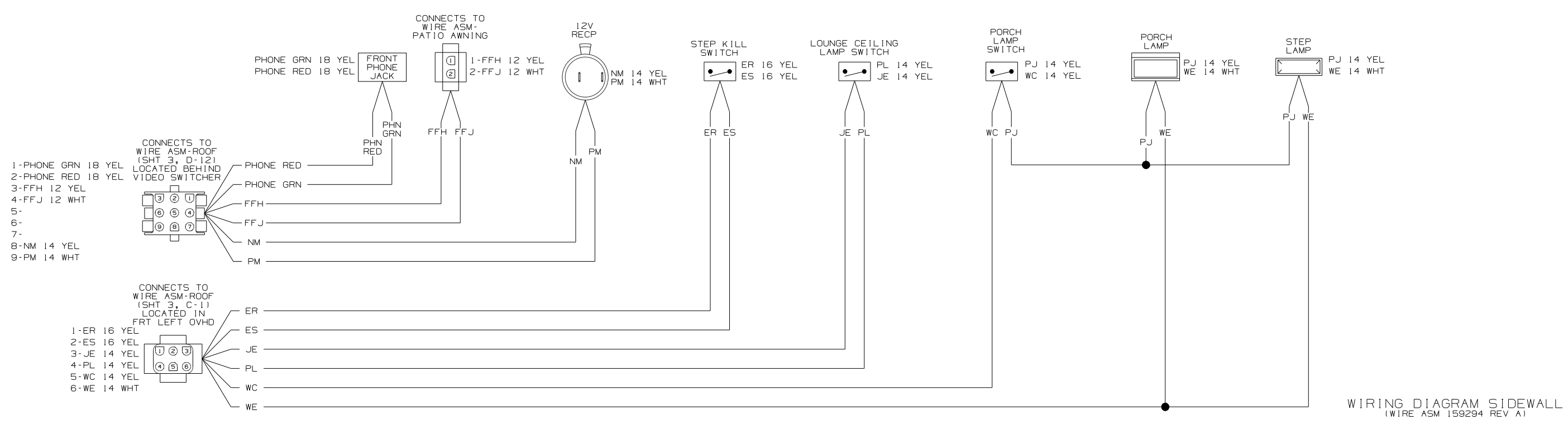

1 NOT USED ON THIS UNIT.

FIRST USED	07 F35A
TITLE	DO NOT SCALE DRAWING
TITLE	WIRING DIAGRAM-BODY, 12V
SHEET 5	PART NO 159098
	REV

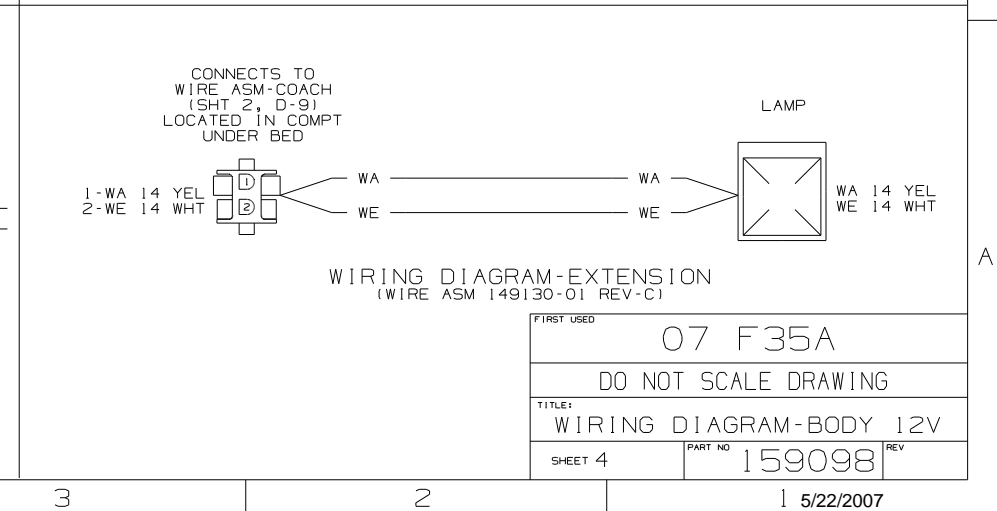
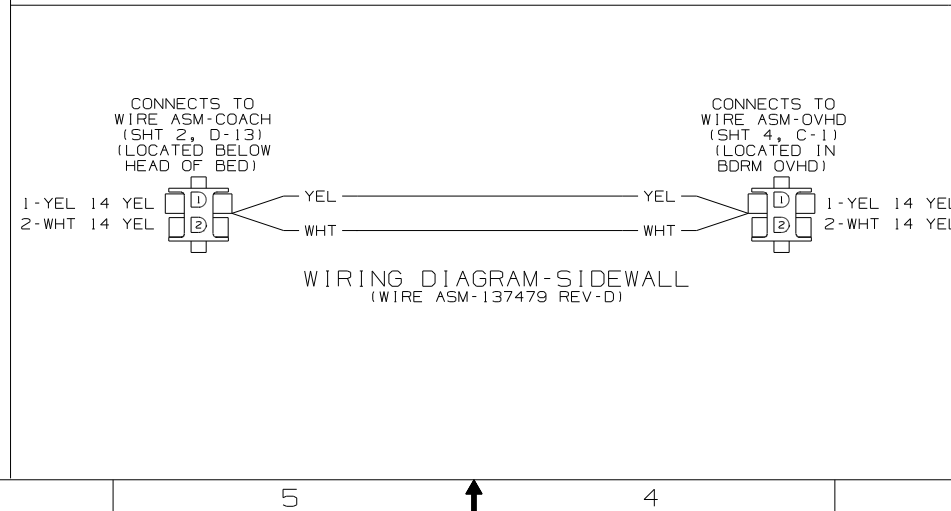
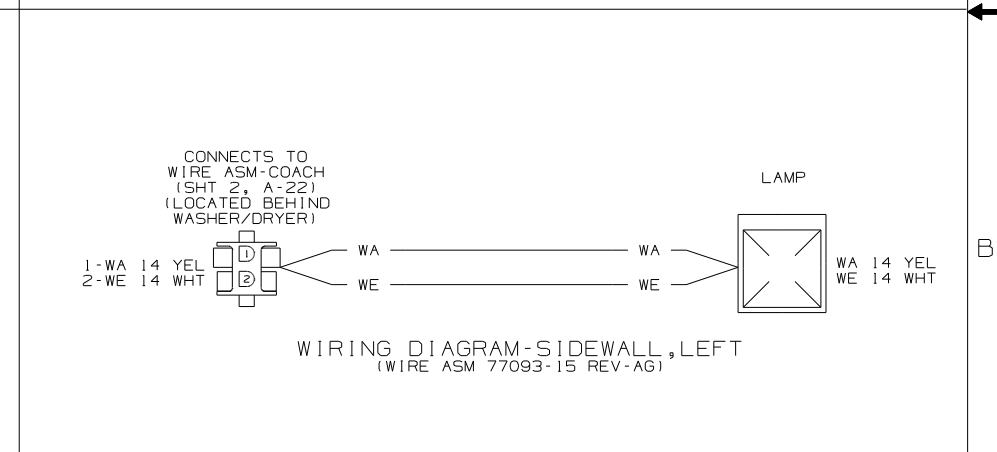
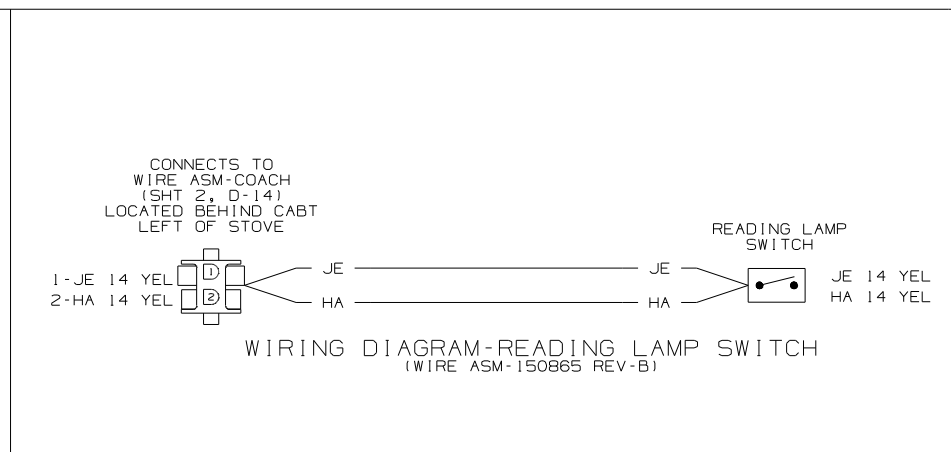
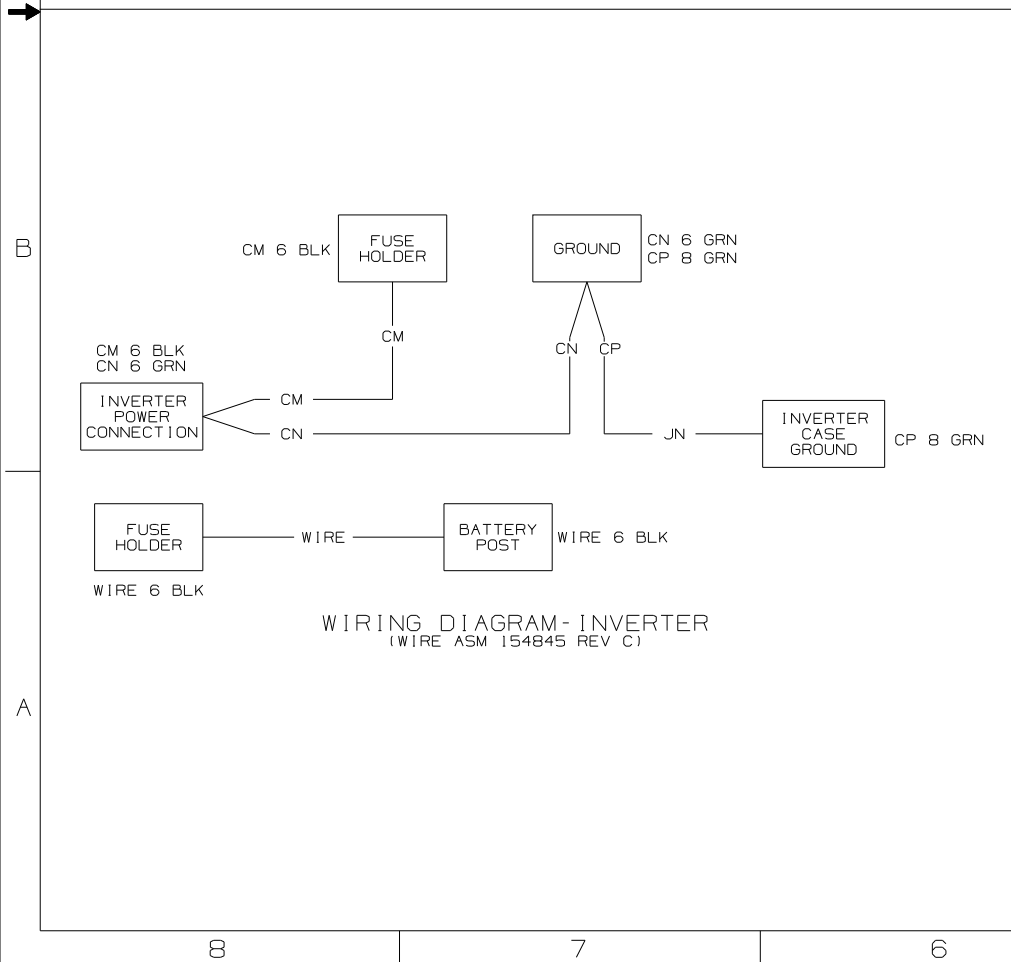
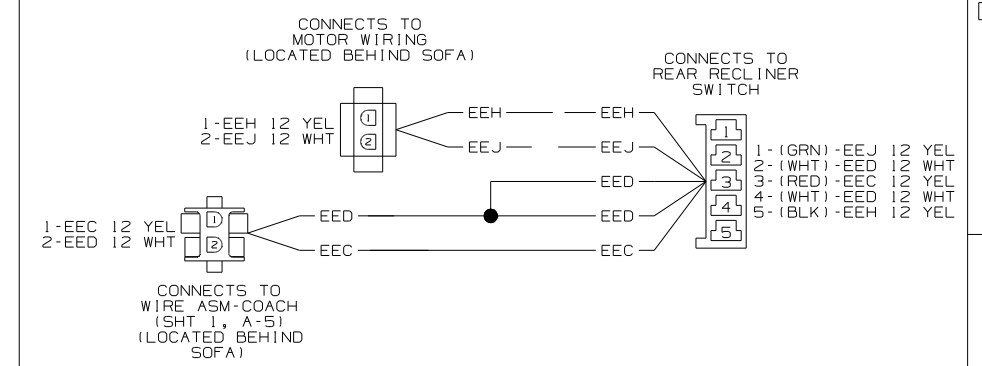
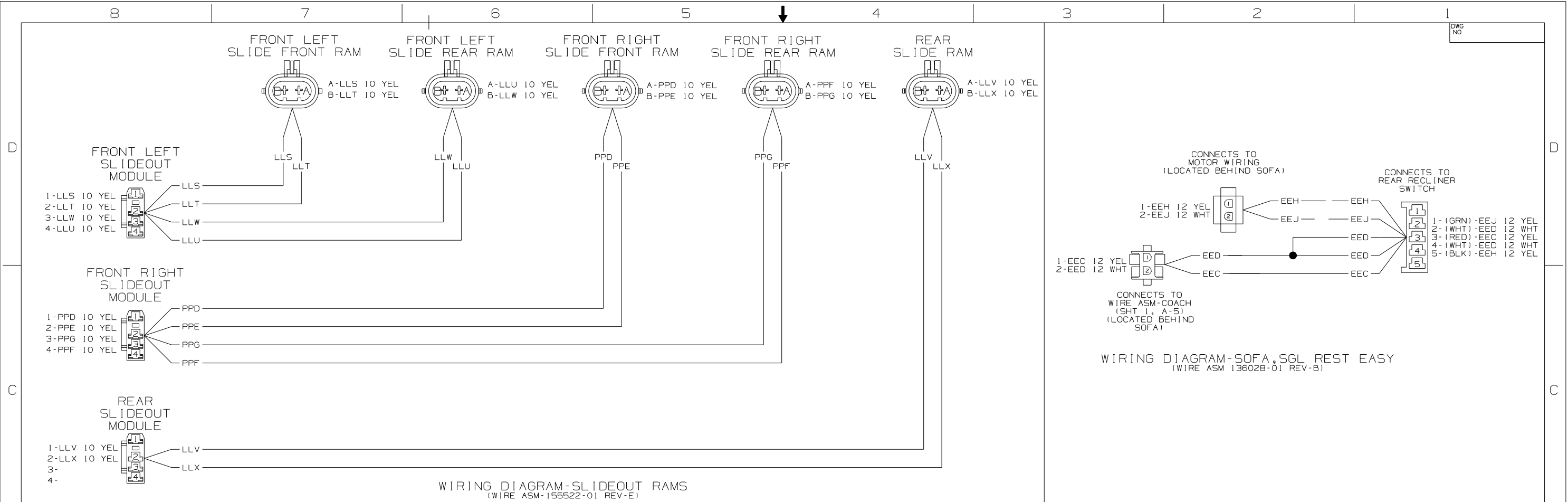

FIRST USED	07 F35A
TITLE	DO NOT SCALE DRAWING
TITLE	WIRING DIAGRAM-BODY 12V
SHEET 4	PART NO 159098 REV

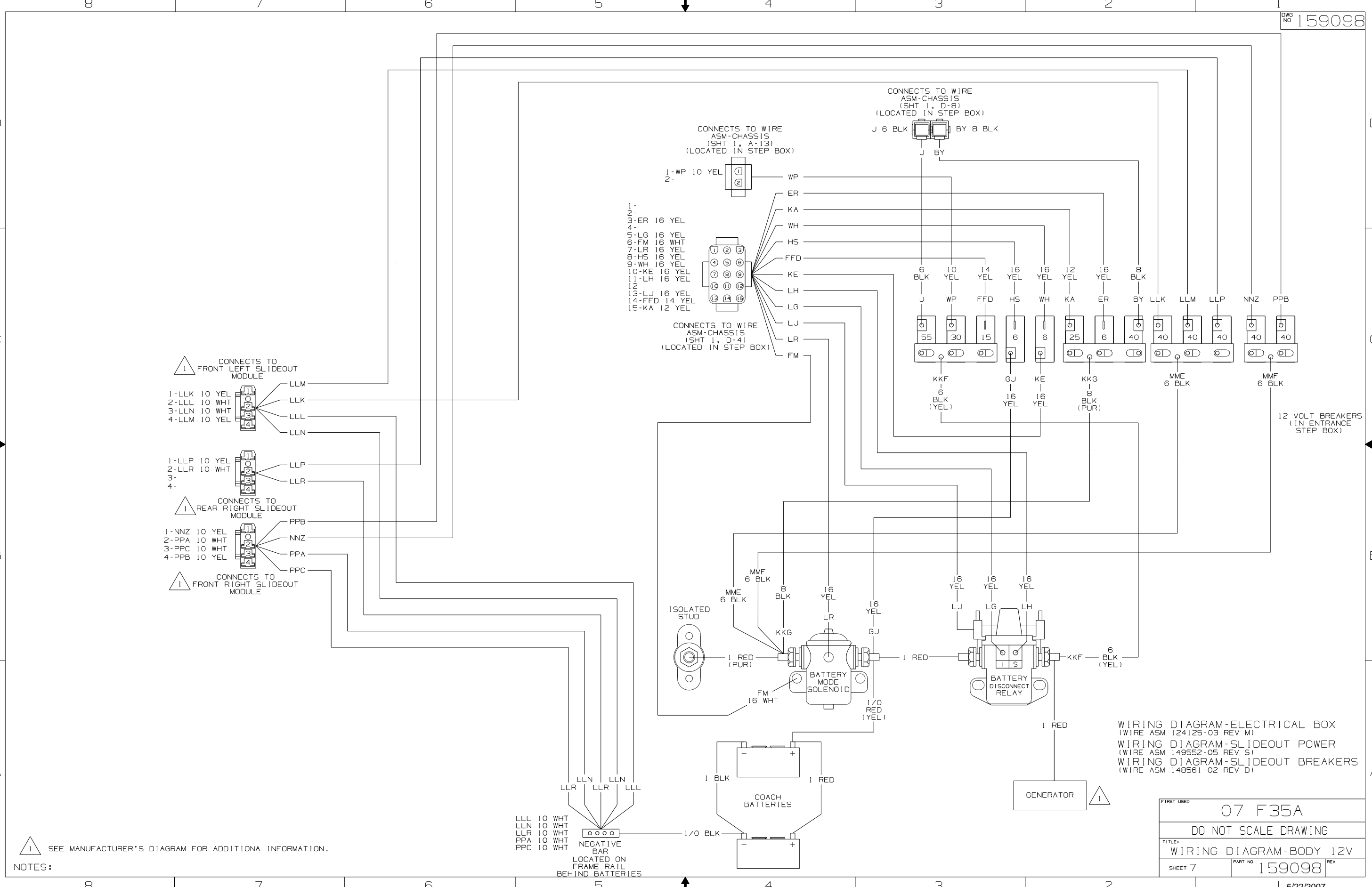

CONNECTS TO FRONT LEFT SLIDEOUT MODULE
1-LLK 10 YEL
2-LLL 10 WHT
3-LLN 10 WHT
4-LLM 10 YEL

CONNECTS TO REAR RIGHT SLIDEOUT MODULE
1-LLP 10 YEL
2-LLR 10 WHT
3-
4-

CONNECTS TO FRONT RIGHT SLIDEOUT MODULE
1-NNZ 10 YEL
2-PPA 10 WHT
3-PPC 10 WHT
4-PPB 10 YEL

CONNECTS TO WIRE ASM-CHASSIS (SHT 1, A-13) (LOCATED IN STEP BOX)
1-WP 10 YEL
2-

CONNECTS TO WIRE ASM-CHASSIS (SHT 1, D-4) (LOCATED IN STEP BOX)
1-
2-
3-ER 16 YEL
4-
5-LG 16 YEL
6-FM 16 WHT
7-LR 16 YEL
8-HS 16 YEL
9-WH 16 YEL
10-KE 16 YEL
11-LH 16 YEL
12-
13-LJ 16 YEL
14-FFD 14 YEL
15-KA 12 YEL

CONNECTS TO WIRE ASM-CHASSIS (SHT 1, D-8) (LOCATED IN STEP BOX)
J 6 BLK BY 8 BLK

WIRING DIAGRAM-ELECTRICAL BOX (WIRE ASM 124125-03 REV M)
WIRING DIAGRAM-SLIDEOUT POWER (WIRE ASM 149552-05 REV S)
WIRING DIAGRAM-SLIDEOUT BREAKERS (WIRE ASM 148561-02 REV D)

FIRST USED	07 F35A
DO NOT SCALE DRAWING	
TITLE: WIRING DIAGRAM-BODY 12V	
SHEET 7	PART NO 159098 REV

NOTES:
1 SEE MANUFACTURER'S DIAGRAM FOR ADDITIONAL INFORMATION.

LLL 10 WHT
LLN 10 WHT
LLR 10 WHT
PPA 10 WHT
PPC 10 WHT
NEGATIVE BAR
LOCATED ON FRAME RAIL
BEHIND BATTERIES

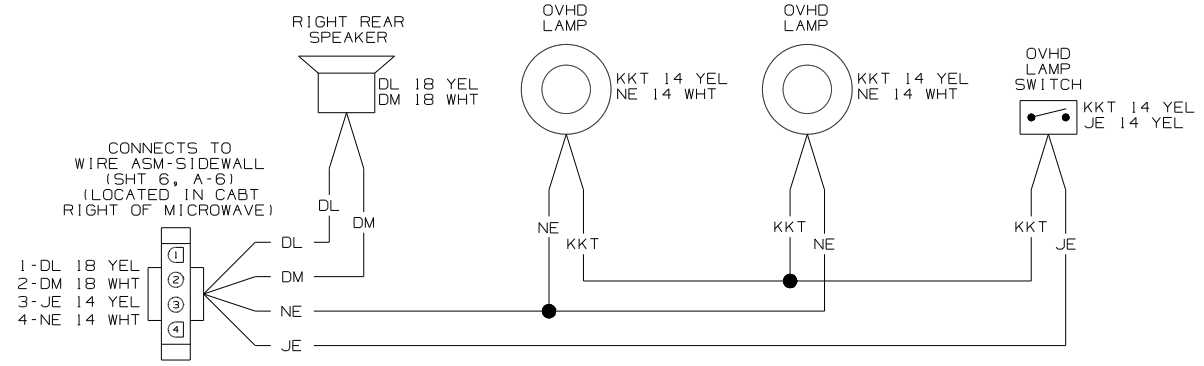

WIRING DIAGRAM-OVHD, SLIDEOUT
(WIRE ASM 159292 REV-A)

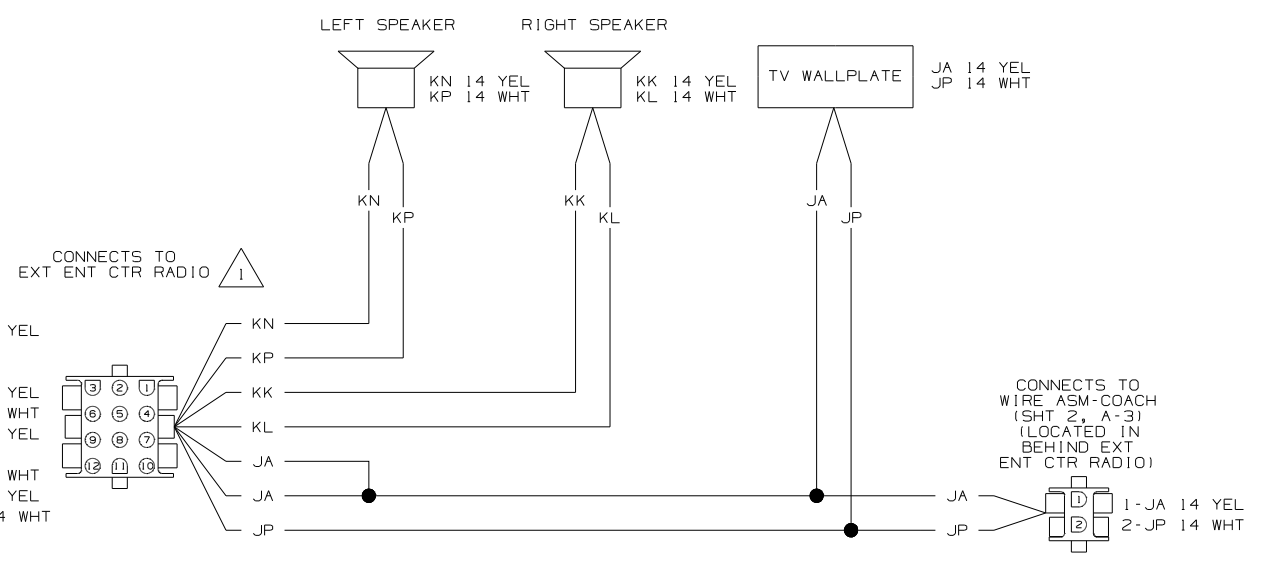

WIRING DIAGRAM-ENTERTAINMENT CTR
(WIRE ASM 125853-04 REV-L)

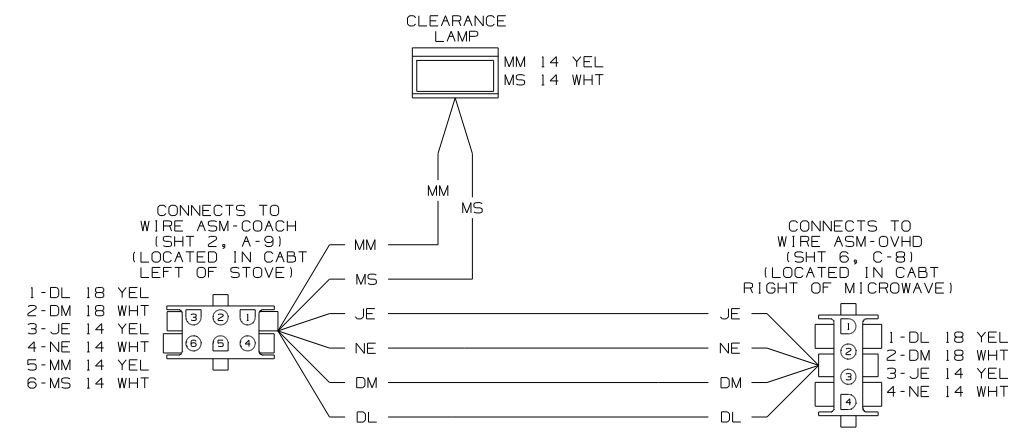

WIRING DIAGRAM-SIDEWALL
(WIRE ASM 159293 REV-A)

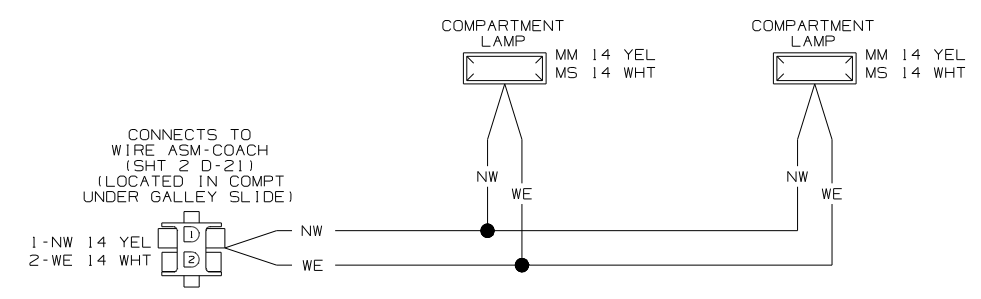

WIRING DIAGRAM-COMPT LAMPS
(WIRE ASM 151912 REV-D)

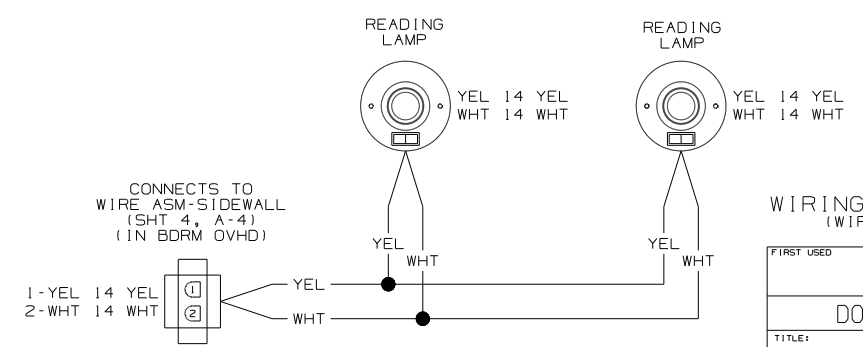

WIRING DIAGRAM-OVHD LAMPS
(WIRE ASM 133574-04 REV-A)

FIRST USED	07 F35A	
TITLE	DO NOT SCALE DRAWING	
	WIRING DIAGRAM-BODY 12V	
SHEET 6	PART NO	159098
	REV	