



**DANGER**

**Danger of electrical shock, burns or death.** Always remove all power sources before attempting any repair, service or diagnostic work. Power can be present from shore power, generator, inverter or battery. All power sources must be disabled and secured before performing any service.



**CAUTION**

If you lack the skills, tools or equipment to perform diagnostic or repair work leave such work to an authorized Winnebago Industries dealer or other qualified shop.

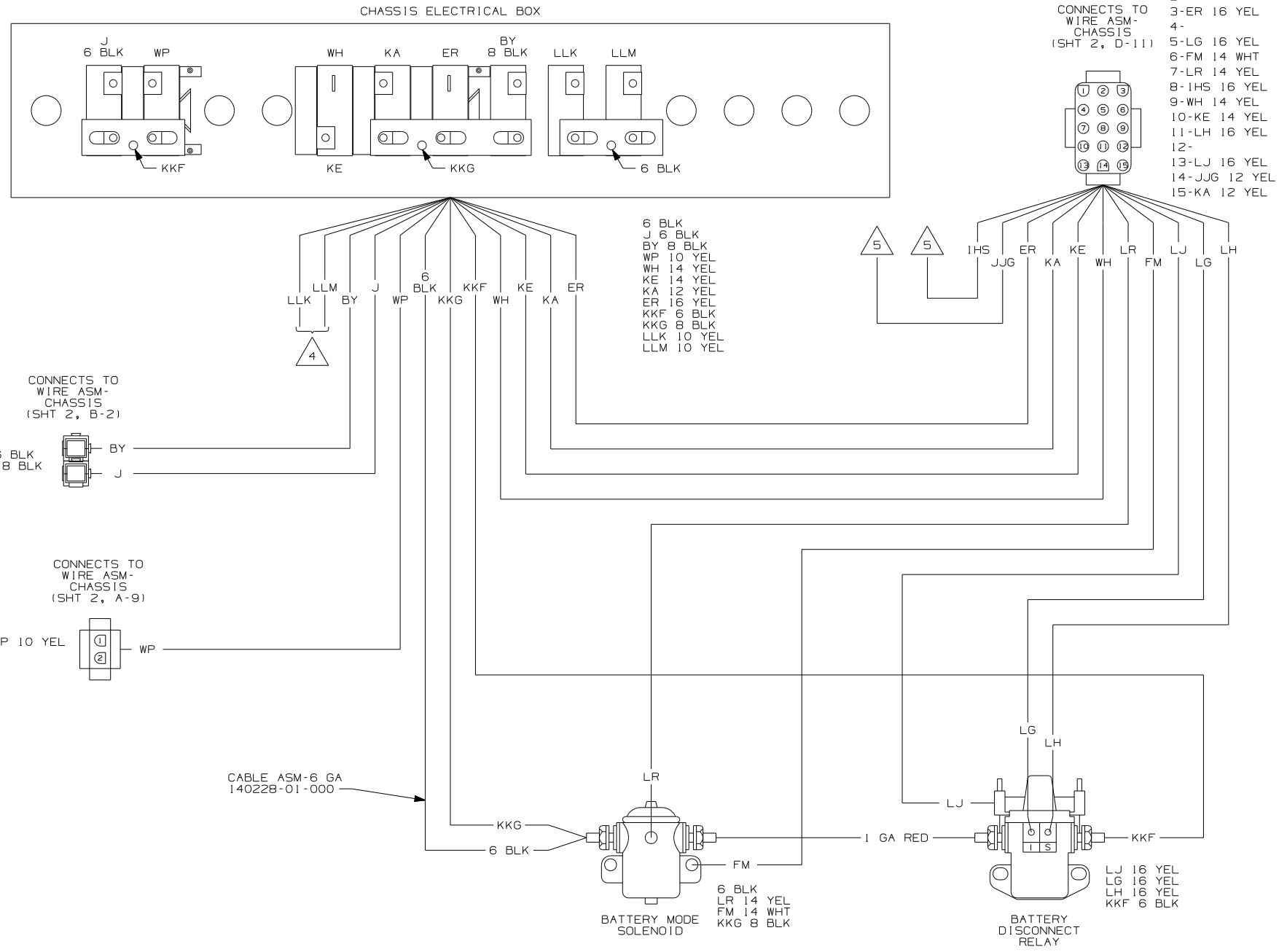

- 5 CIRCUIT IS NOT USED.
- 4 WIRE IS FROM WIRE ASM-SLIDEOUT POWER.
- 3 SEE WIRING DIAGRAM-AUTO FOR ADDITIONAL INFORMATION.
- 2 SEE MANUFACTURERS DIAGRAM FOR ADDITIONAL INFORMATION.

1. SPLICES ARE THEORETICAL AND MAY DIFFER IN THE HARNESS.

NOTES:

WIRING DIAGRAM-ELECTRICAL BOX  
(WIRE ASM 124125-03 REV-L)

<b>WINNEBAGO</b>		COPYRIGHT 2006 WINNEBAGO INDUSTRIES, INC.	
DFTR	ORIG. DATE	ALL DIMENSIONS ARE IN MILLIMETERS	
CHKR			
P.E.			
M.E.	FIRST USED	07 D30B	
DSNR			
UNSPECIFIED TOLERANCES ARE:		MATERIAL:	
WHOLE DIM (X)	:		
ONE-PLACE (X.X)	:		
TWO-PLACE (X.XX)	:		
ANGLE	:		
THIRD ANGLE PROJECTION			
DO NOT SCALE DRAWING			
TITLE: WIRING DIAGRAM-BODY, 12V			
SHEET 1 OF 6	PART NO	157569	REV
REF:		1 9/8/2006	

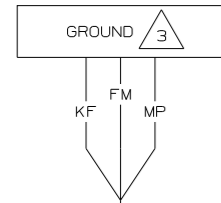

KF 16 WHT  
FM 14 WHT  
MP 16 WHT

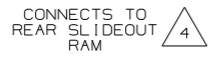

A-GGK 18 YEL  
B-GGM 18 WHT  
C-GGL 18 YEL

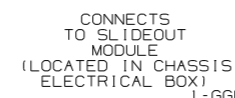
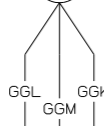

GGK GGL GGJ GGG

GGM GGH

GGJ GGG



A-GGG 18 YEL  
B-GGJ 18 WHT  
C-GGH 18 YEL

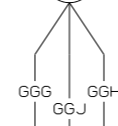

- 1-GGH 18 YEL
- 2-GGG 18 YEL
- 3-GGJ 18 WHT
- 4-GGL 18 YEL
- 5-GGK 18 YEL
- 6-GGM 18 WHT

GND

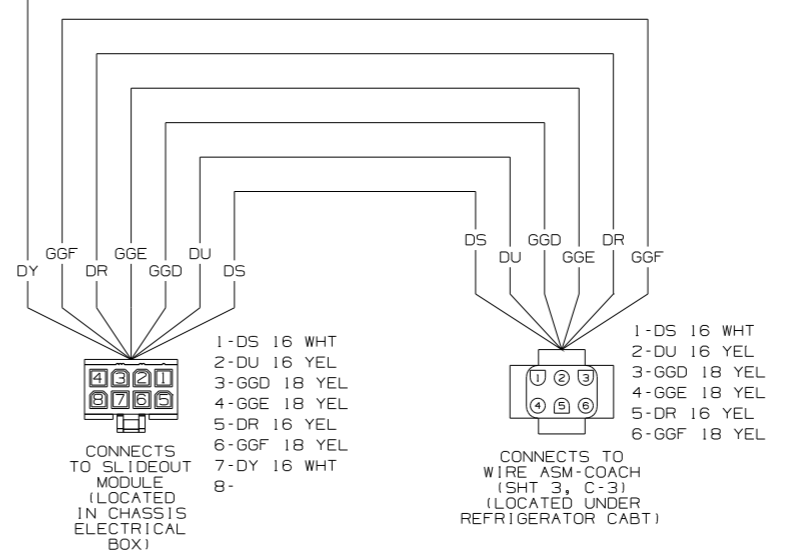
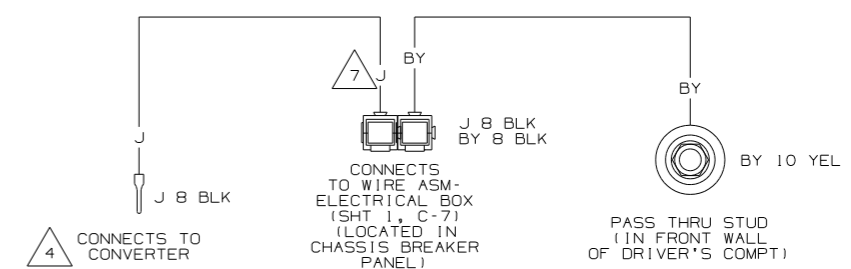
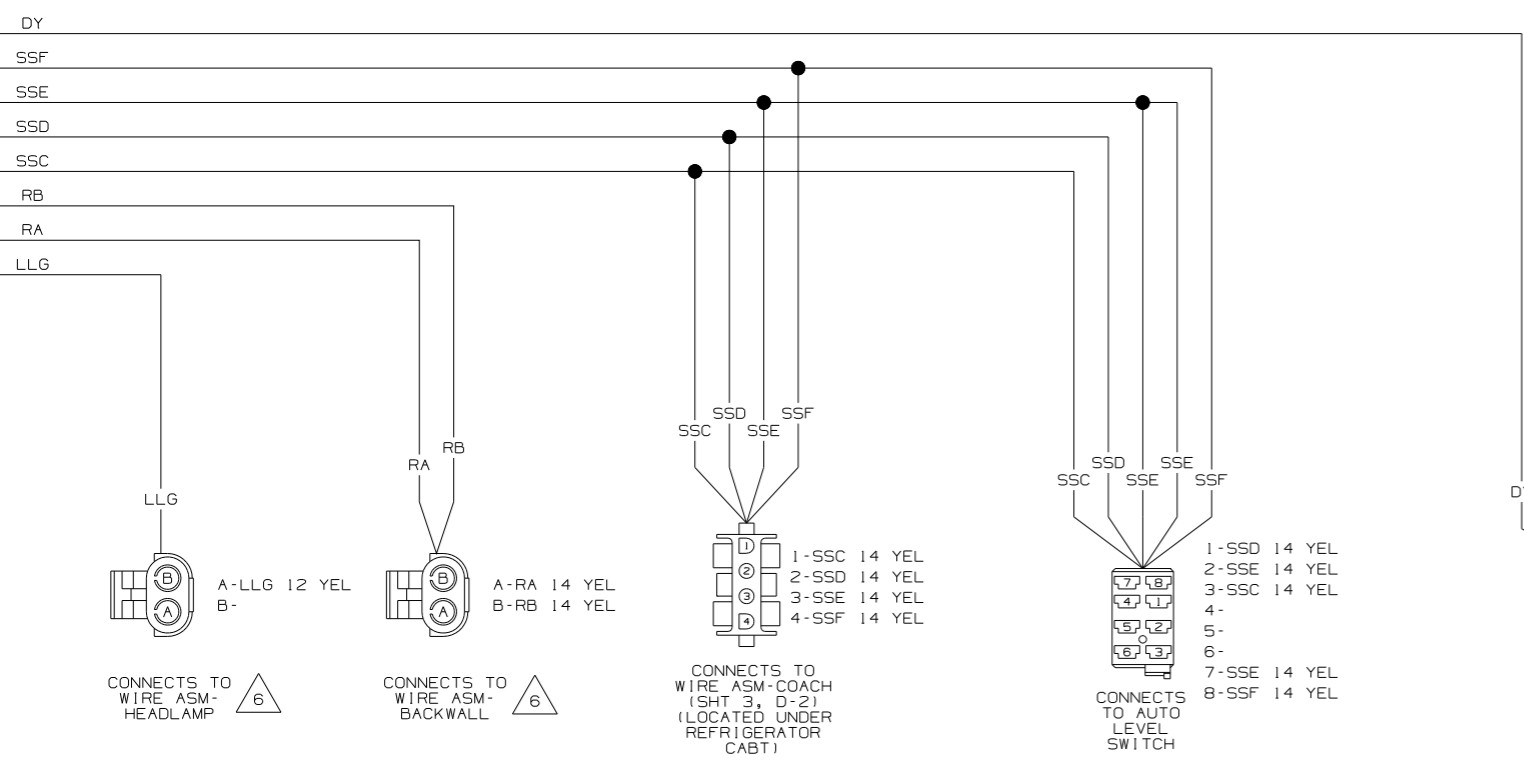

WIRING DIAGRAM-CHASSIS (WIRE ASM 158142 REV-J)

FIRST USED	07 D30B	
DO NOT SCALE DRAWING		
TITLE	WIRING DIAGRAM-BODY, 12V	
SHEET 2	PART NO	157569
		REV

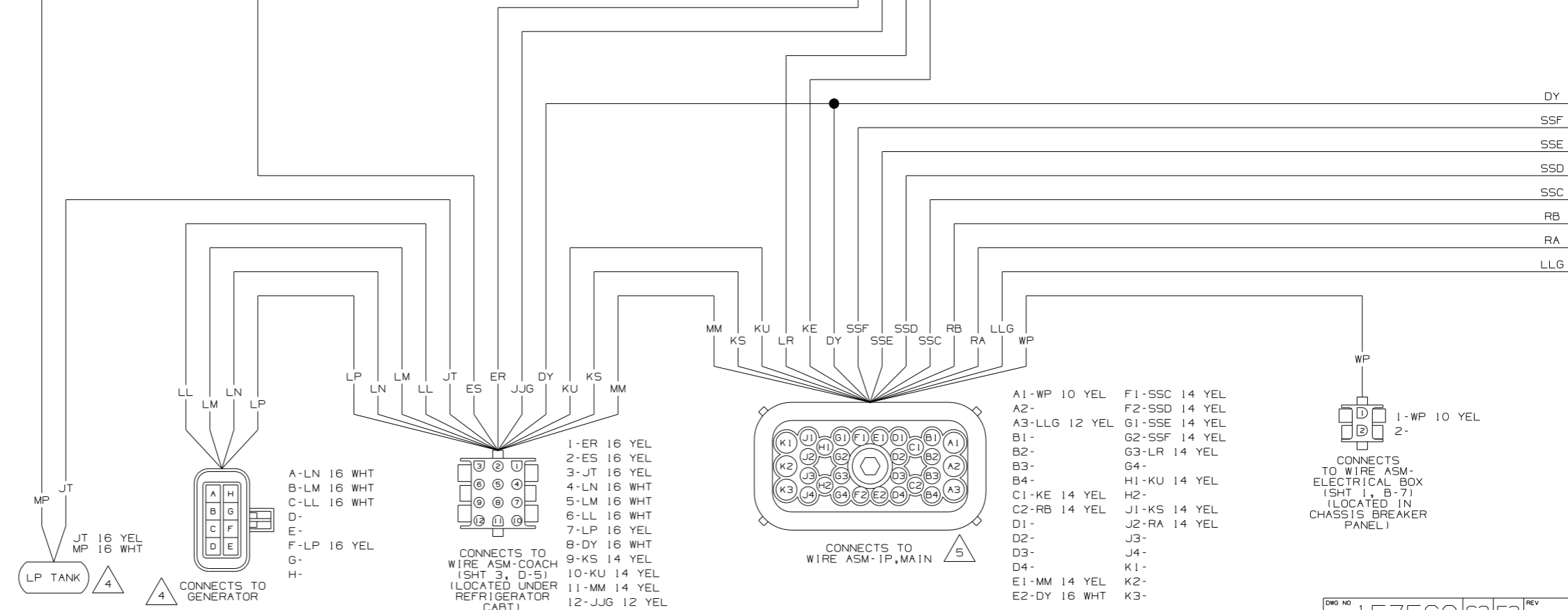
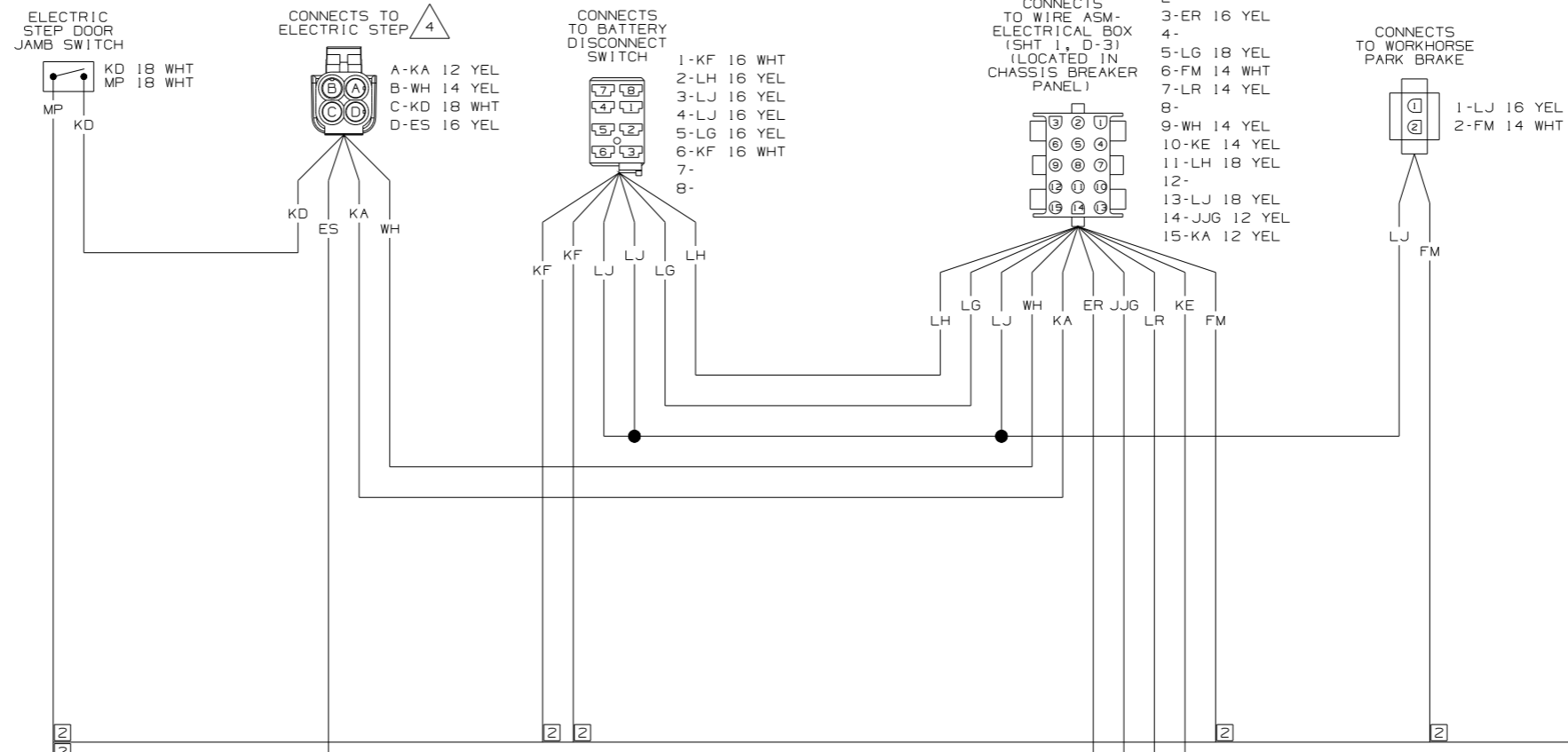

- 7 WIRE IS MARKED WITH YELLOW TAPE.
  - 6 WIRE IS FROM WIRE ASM-CHASSIS.
  - 5 SEE WIRING DIAGRAM-AUTO FOR ADDITIONAL INFORMATION.
  - 4 SEE MANUFACTURERS DIAGRAM FOR ADDITIONAL INFORMATION.
  - 3 GROUNDS ARE SHOWN AS A SINGLE LINE FOR EASE IN TRACING. EACH GROUND CIRCUIT IS SEPERATE IN THE HARNESS.
  - 2 NOT A SPLICE POINT. INDICATES ENTRY INTO WIRING HARNESS.
- NOTES:  
 1. SPLICES ARE THEORETICAL AND MAY DIFFER IN THE HARNESS.

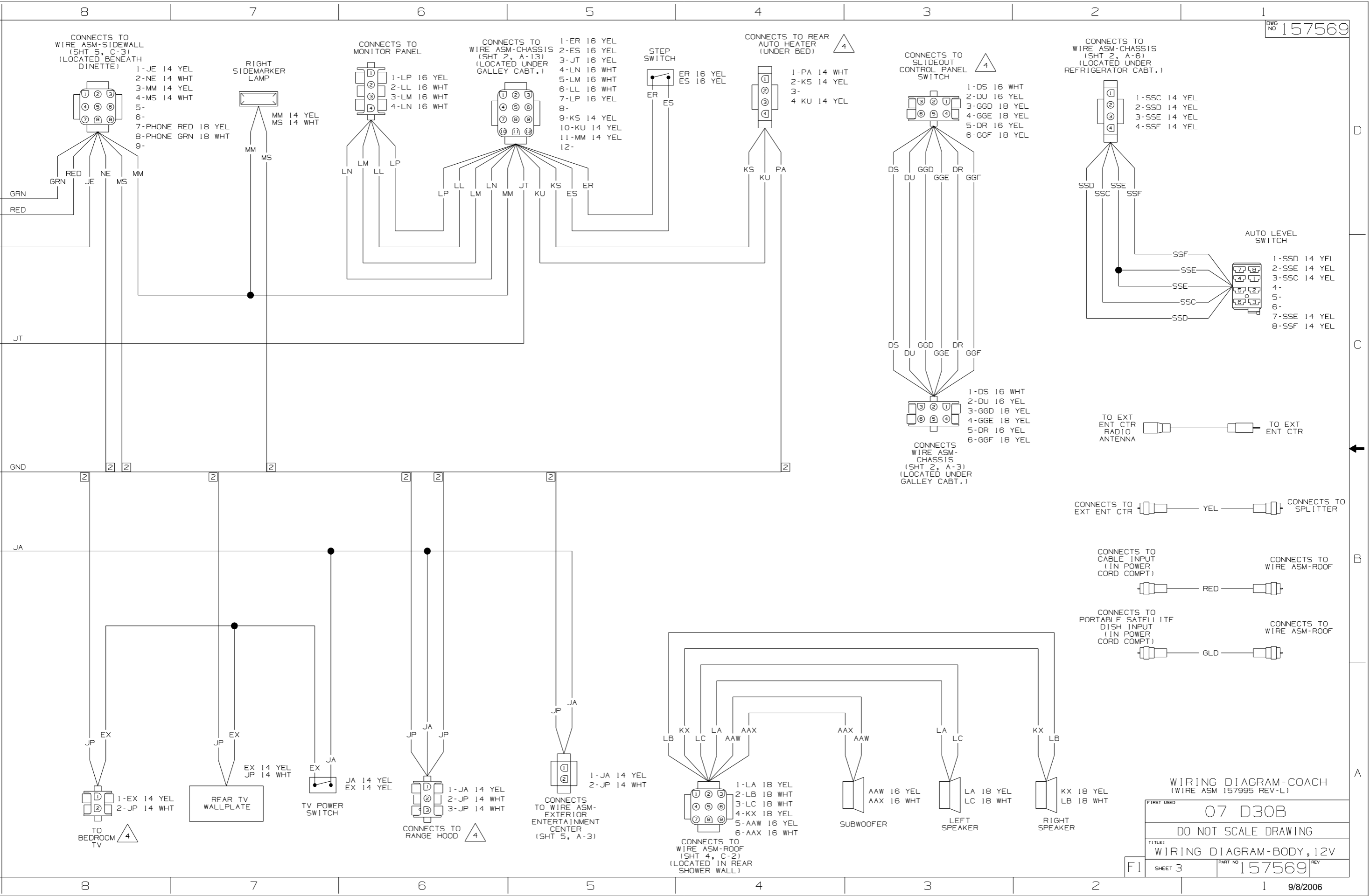

CONNECTS TO WIRE ASM-SIDEWALL (SHT 5, C-3) (LOCATED BENEATH DINETTE)

- 1-JE 14 YEL
- 2-NE 14 WHT
- 3-MM 14 YEL
- 4-MS 14 WHT
- 5-
- 6-
- 7-PHONE RED 18 YEL
- 8-PHONE GRN 18 WHT
- 9-

RIGHT SIDEMARKER LAMP

- MM 14 YEL
- MS 14 WHT

CONNECTS TO MONITOR PANEL

- 1-LP 16 YEL
- 2-LL 16 WHT
- 3-LM 16 WHT
- 4-LN 16 WHT

CONNECTS TO WIRE ASM-CHASSIS (SHT 2, A-13) (LOCATED UNDER GALLEY CABT.)

- 1-ER 16 YEL
- 2-ES 16 YEL
- 3-JT 16 YEL
- 4-LN 16 WHT
- 5-LM 16 WHT
- 6-LL 16 WHT
- 7-LP 16 YEL
- 8-
- 9-KS 14 YEL
- 10-KU 14 YEL
- 11-MM 14 YEL
- 12-

STEP SWITCH

- ER 16 YEL
- ES 16 YEL

CONNECTS TO REAR AUTO HEATER (UNDER BED)

- 1-PA 14 WHT
- 2-KS 14 YEL
- 3-
- 4-KU 14 YEL

CONNECTS TO SLIDEOUT CONTROL PANEL SWITCH

- 1-DS 16 WHT
- 2-DU 16 YEL
- 3-GGD 18 YEL
- 4-GGE 18 YEL
- 5-DR 16 YEL
- 6-GGF 18 YEL

CONNECTS TO WIRE ASM-CHASSIS (SHT 2, A-6) (LOCATED UNDER REFRIGERATOR CABT.)

- 1-SSC 14 YEL
- 2-SSD 14 YEL
- 3-SSE 14 YEL
- 4-SSF 14 YEL

AUTO LEVEL SWITCH

- 1-SSD 14 YEL
- 2-SSE 14 YEL
- 3-SSC 14 YEL
- 4-
- 5-
- 6-
- 7-SSE 14 YEL
- 8-SSF 14 YEL

TO EXT ENT CTR RADIO ANTENNA

TO EXT ENT CTR

CONNECTS TO EXT ENT CTR

YEL

CONNECTS TO SPLITTER

CONNECTS TO CABLE INPUT (IN POWER CORD COMPT)

RED

CONNECTS TO WIRE ASM-ROOF

CONNECTS TO PORTABLE SATELLITE DISH INPUT (IN POWER CORD COMPT)

GLD

CONNECTS TO WIRE ASM-ROOF

WIRING DIAGRAM-COACH (WIRE ASM 157995 REV-L)

FIRST USED 07 D30B

DO NOT SCALE DRAWING

TITLE: WIRING DIAGRAM-BODY, 12V

SHEET 3

PART NO 157569 REV

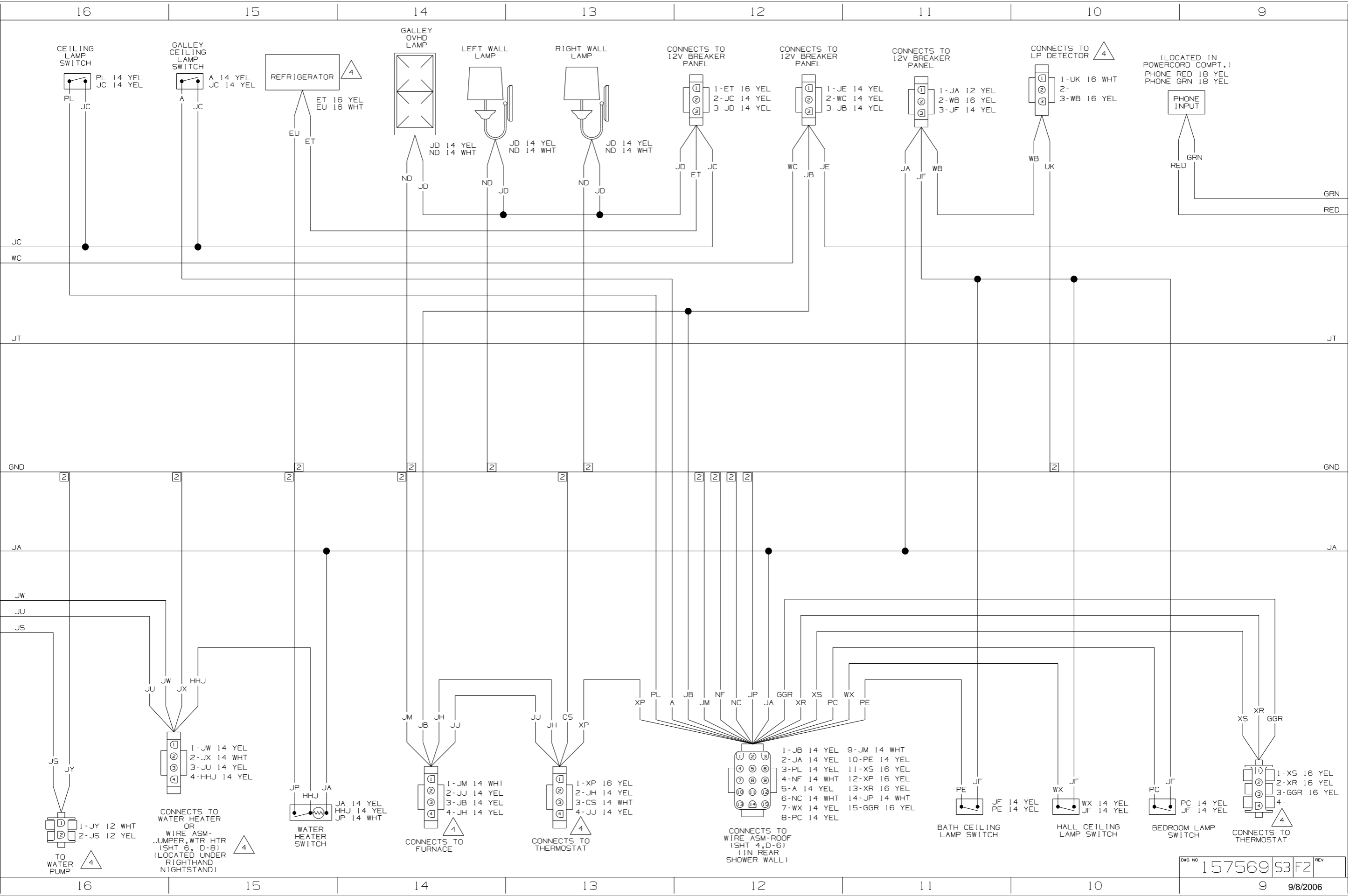

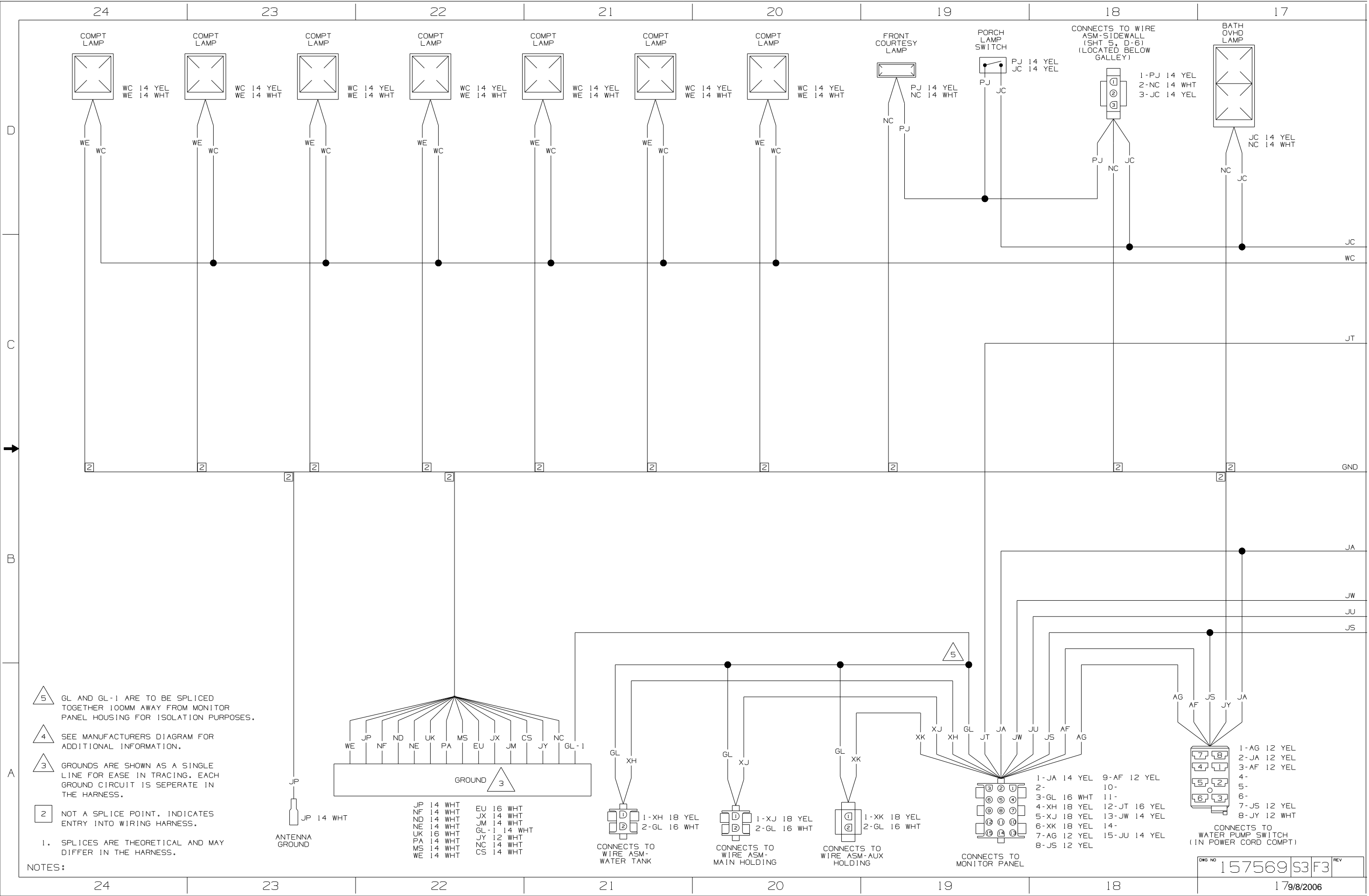

NOTES:

DWG NO 157569 S3F3 REV

17/9/2006

CONNECTS TO WIRE ASM-COACH (SHT 3, A-12) (IN REAR SHOWER WALL)

- 1-JB 14 YEL
- 2-JA 14 YEL
- 3-PL 14 YEL
- 4-NF 14 WHT
- 5-A 14 YEL
- 6-NC 14 WHT
- 7-WX 14 YEL
- 8-PC 14 YEL
- 9-JM 14 WHT
- 10-PE 14 YEL
- 11-XS 16 YEL
- 12-XP 16 YEL
- 13-XR 16 YEL
- 14-JP 14 WHT
- 15-GGR 16 YEL

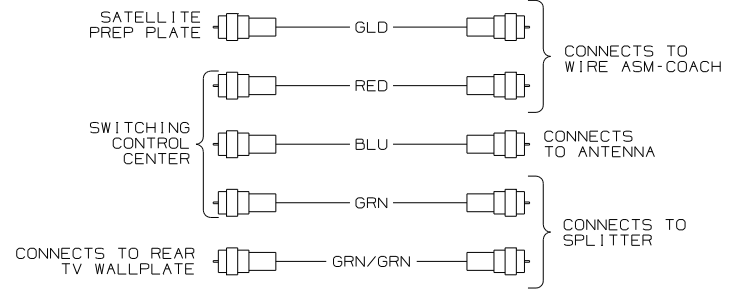

CONNECTS TO WIRE ASM-COACH (SHT 3, A-4) (IN REAR SHOWER WALL)

- 1-LA 18 YEL
- 2-LB 18 WHT
- 3-LC 18 WHT
- 4-KX 18 YEL
- 5-SUB POS 16 YEL
- 6-SUB NEG 16 WHT

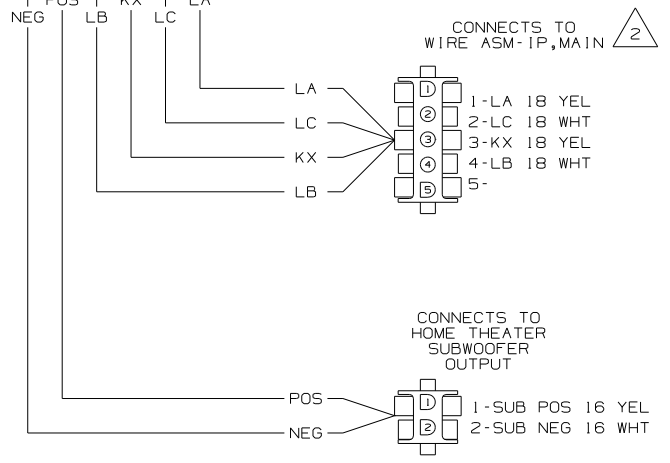

WIRING DIAGRAM-ROOF (WIRE ASM 158356 REV-H)



- GGR 16 YEL
- JM 14 WHT
- XR 16 YEL
- XS 16 YEL
- XP 16 YEL

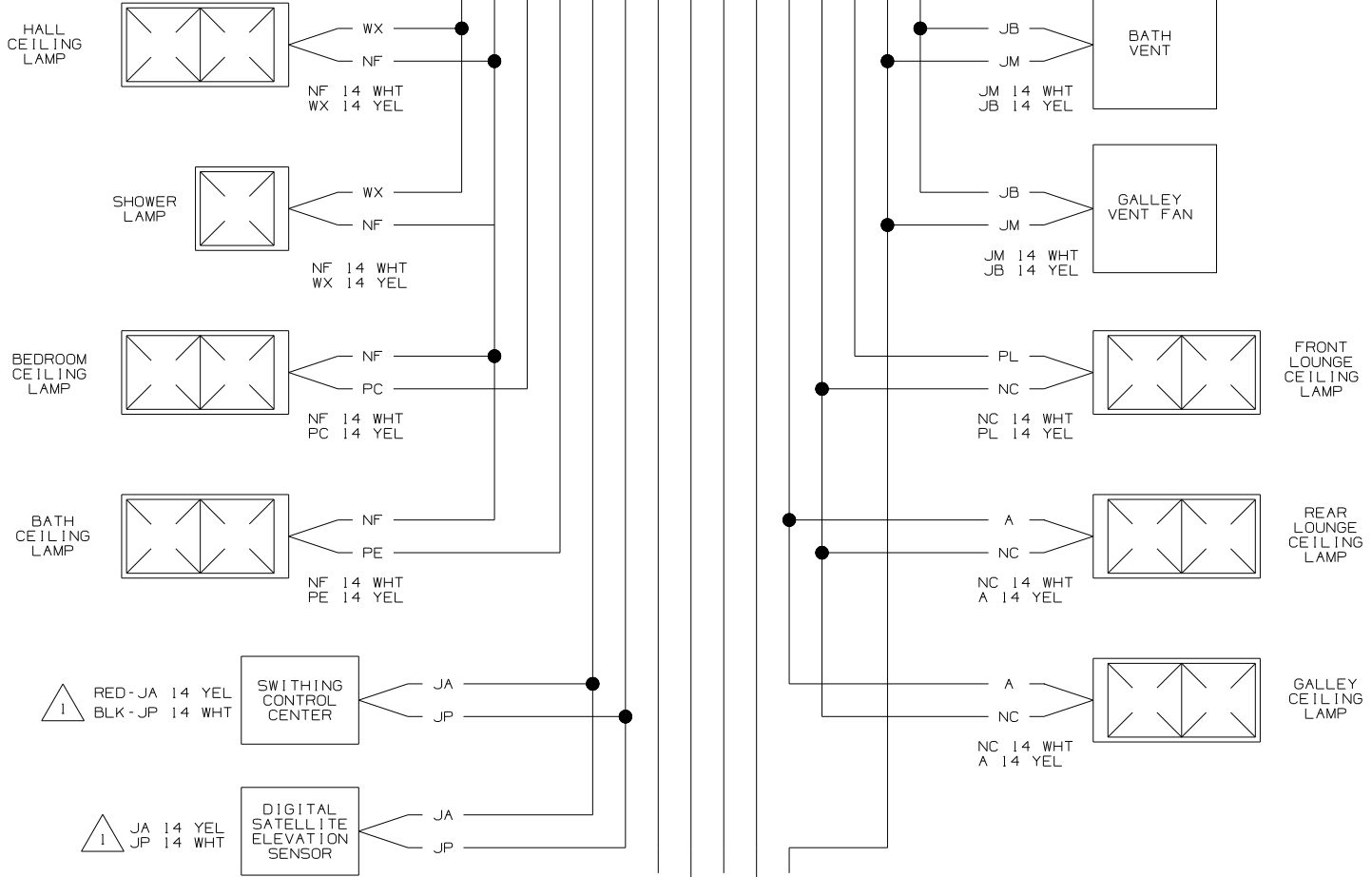

2 SEE WIRING DIAGRAM-AUTO FOR ADDITIONAL INFORMATION.

1 SEE MANUFACTURERS DIAGRAM FOR ADDITIONAL INFORMATION.

NOTES:

FIRST USED	07 D30B
TITLE	DO NOT SCALE DRAWING
TITLE	WIRING DIAGRAM-BODY, 12V
SHEET 4	PART NO 157569 REV



CONNECTS TO WIRE ASM-SIDEWALL (SHT 5, D-1) (LOCATED IN DINETTE OVHD)

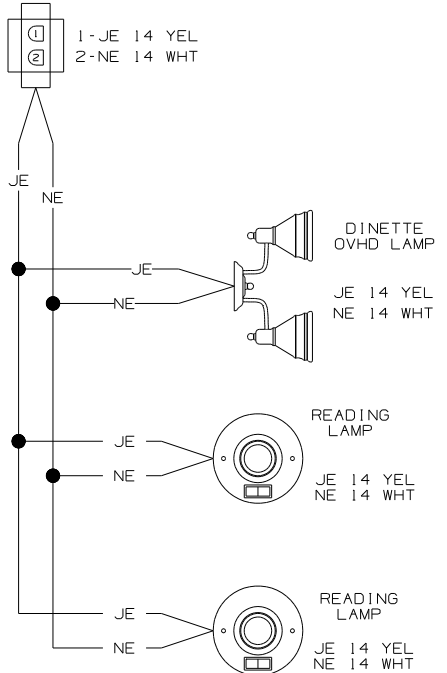

WIRING DIAGRAM-OVHD (WIRE ASM 159317 REV-A)

CONNECTS TO WIRE ASM-COACH (SHT 3, D-18) (LOCATED BELOW GALLEY)

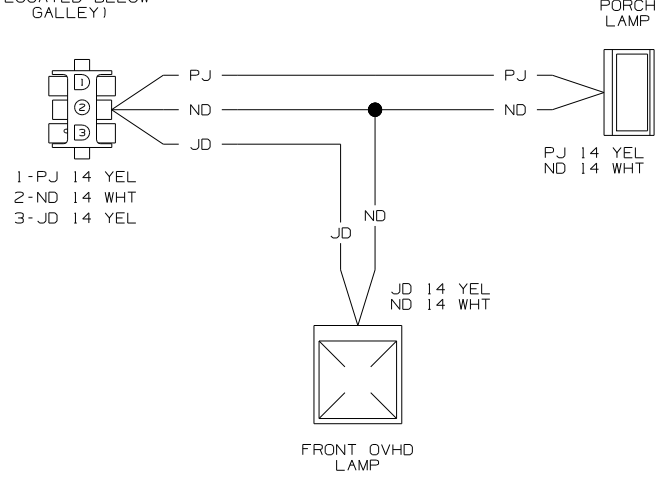

WIRING DIAGRAM-SIDEWALL (WIRE ASM 139038 REV-A)

CONNECTS TO WIRE ASM-COACH (SHT 3, D-8) (LOCATED BENEATH DINETTE)

- 1-JE 14 YEL
- 2-NE 14 WHT
- 3-MM 14 YEL
- 4-MS 14 WHT
- 5-
- 6-
- 7-PHONE RED 16 YEL
- 8-PHONE GRN 16 YEL
- 9-

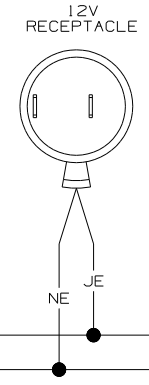

CONNECTS TO WIRE ASM-OVHD (SHT 5, D-8) (LOCATED IN DINETTE OVHD)

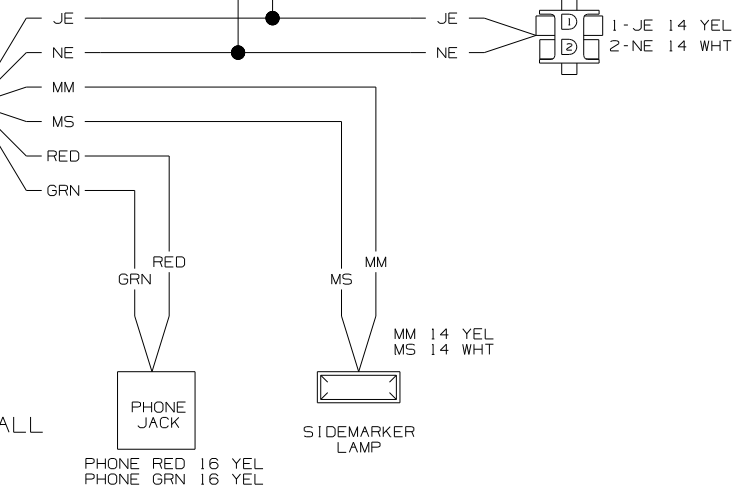

WIRING DIAGRAM-SIDEWALL (WIRE ASM 153100 REV-A)

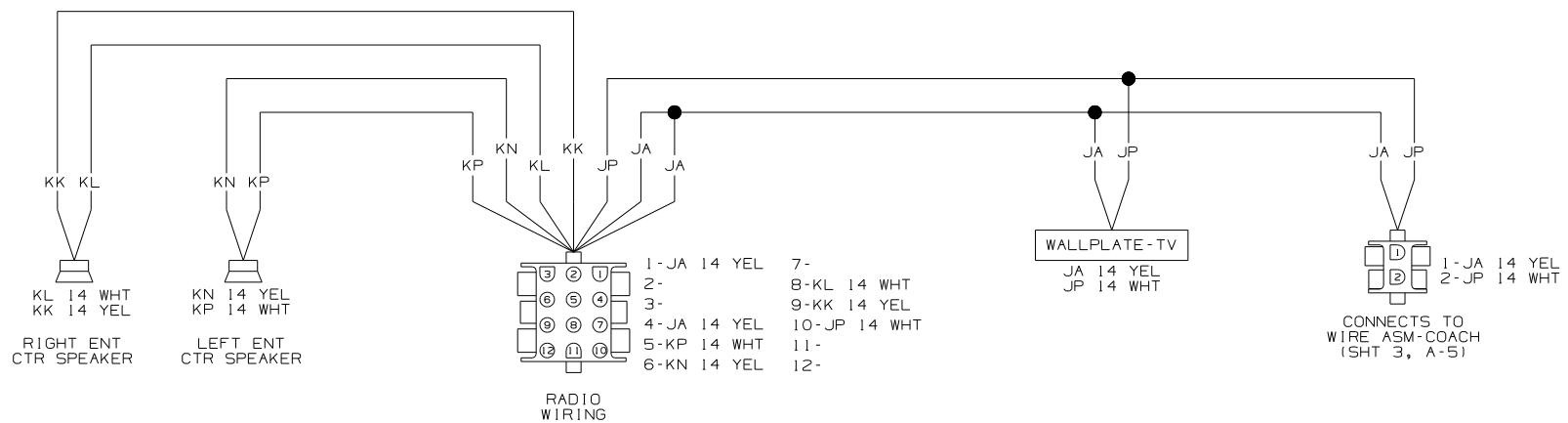

WIRING DIAGRAM-ENTERTAINMENT CENTER (WIRE ASM 125853-04 REV-L)

FIRST USED	07 D30B
TITLE	DO NOT SCALE DRAWING
TITLE	WIRING DIAGRAM-BODY, 12V
SHEET 5	PART NO 157569 REV
	1 9/8/2006

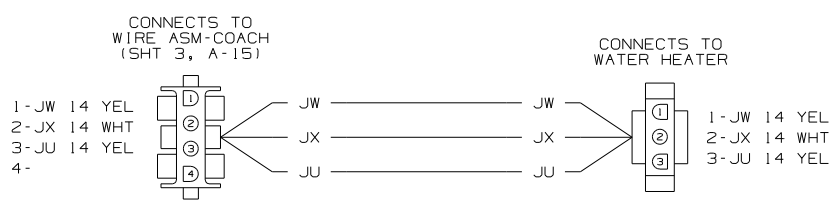

WIRING DIAGRAM-JUMPER, WTR HTR (WIRE ASM 142263 REV-A)

- CONNECTS TO HOME THEATER AMPLIFIER
- 1-RT FRT POS (RED) 18 YEL
  - 2-RT FRT NEG (RED) 18 WHT
  - 3-CENTER POS (GRN) 18 YEL
  - 4-CENTER NEG (GRN) 18 WHT
  - 5-LT FRT POS (WHT) 18 YEL
  - 6-LT FRT NEG (WHT) 18 WHT
  - 7-RT RR POS (GRY) 18 YEL
  - 8-RT RR NEG (GRY) 18 WHT
  - 9-LT RR POS (BLU) 18 YEL
  - 10-LT RR NEG (BLU) 18 WHT
  - 11-SUB POS 16 Y
  - 12-SUB NEG 16 W

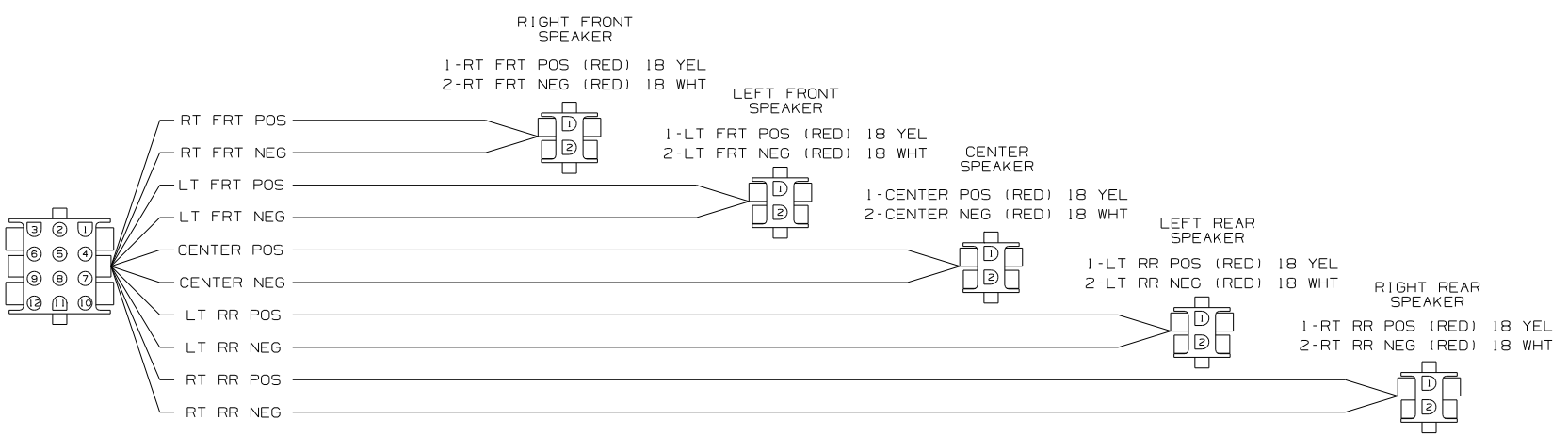

WIRING DIAGRAM-HOME THEATER EXT (WIRE ASM 159963 REV-A)

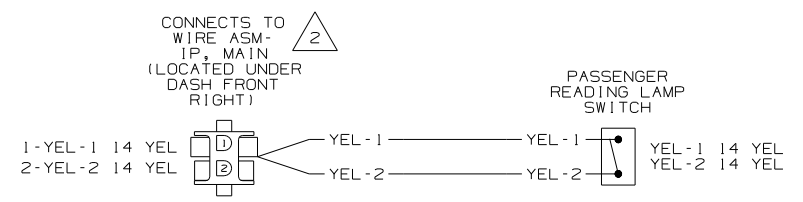

WIRING DIAGRAM-EXTENSION, 2 PIN (WIRE ASM 147579-02 REV-A)

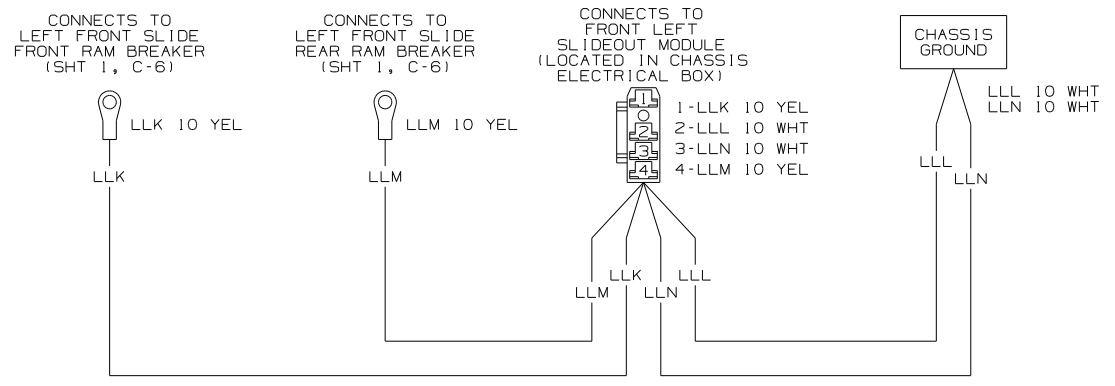

WIRING DIAGRAM-SLIDEOUT POWER (WIRE ASM 149552-04 REV-J)

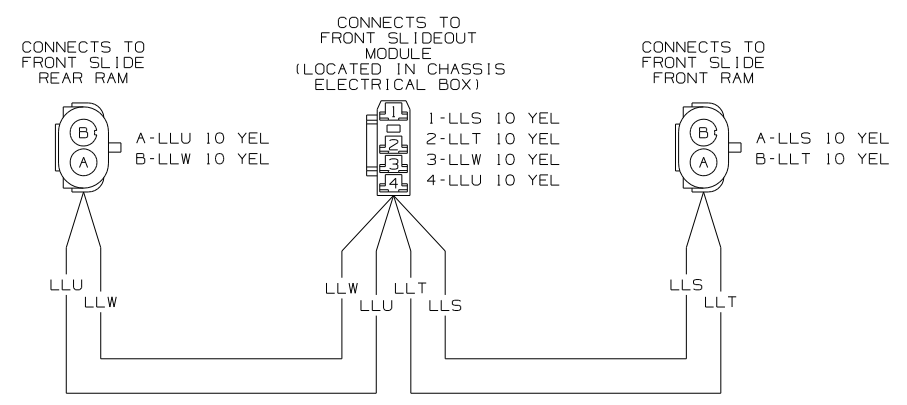

WIRING DIAGRAM-SLIDEOUT RAMS, FRONT (WIRE ASM 149553-01 REV-H)

SEE WIRING DIAGRAM-AUTO FOR ADDITIONAL INFORMATION.

- 1. SPLICES ARE THEORETICAL AND MAY DIFFER IN THE HARNESS.

NOTES:

FIRST USED	07 D30B
TITLE	DO NOT SCALE DRAWING
TITLE	WIRING DIAGRAM-BODY, 12V
SHEET 6	PART NO 157569 REV
	1 9/8/2006