



DANGER

Danger of electrical shock, burns or death. Always remove all power sources before attempting any repair, service or diagnostic work. Power can be present from shore power, generator, inverter or battery. All power sources must be disabled and secured before performing any service.



CAUTION

If you lack the skills, tools or equipment to perform diagnostic or repair work leave such work to an authorized Winnebago Industries dealer or other qualified shop.

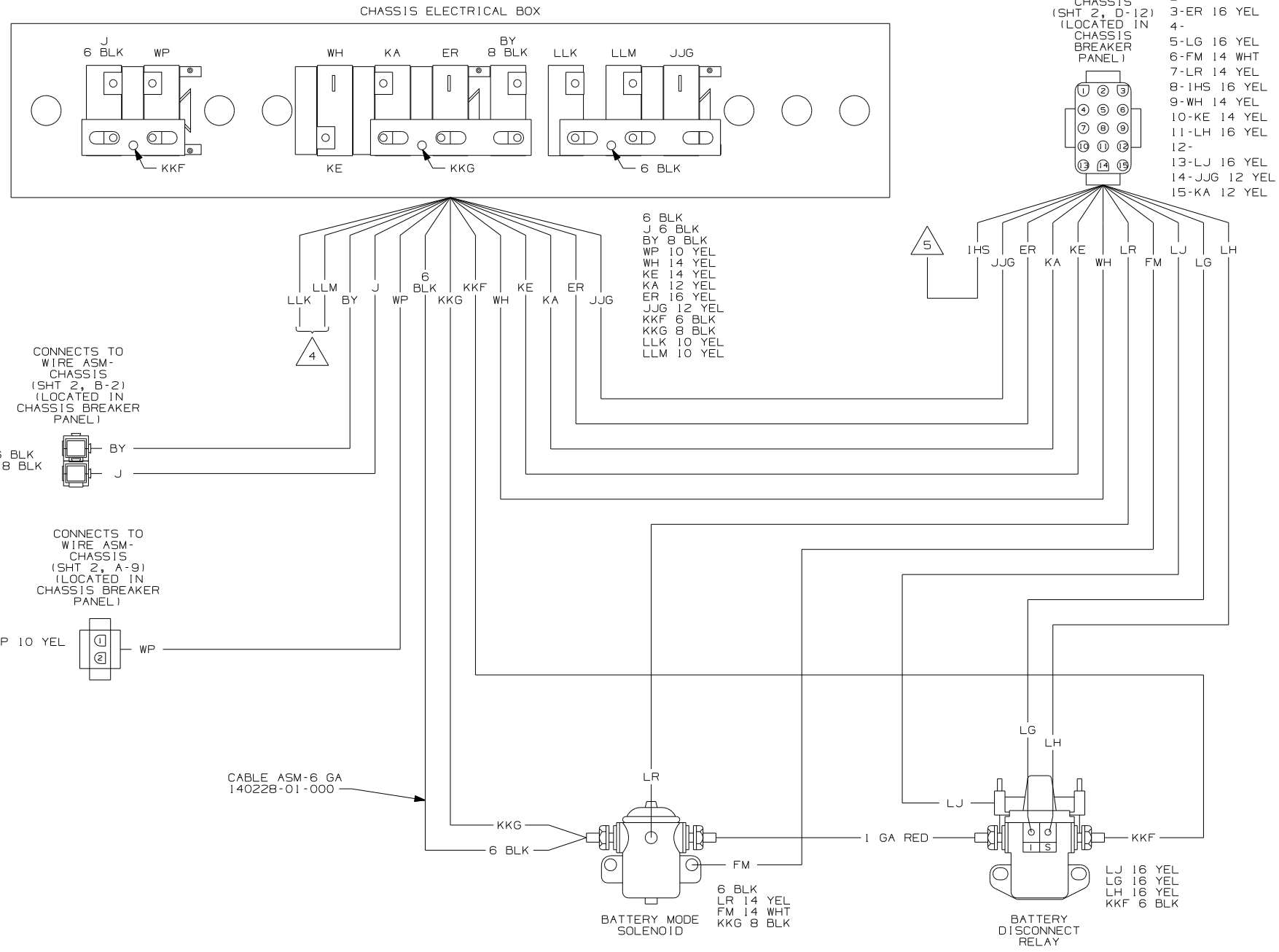

- CONNECTS TO WIRE ASM-CHASSIS (SHT 2, D-12) (LOCATED IN CHASSIS BREAKER PANEL)
- 1-
 - 2-
 - 3-ER 16 YEL
 - 4-
 - 5-LG 16 YEL
 - 6-FM 14 WHT
 - 7-LR 14 YEL
 - 8-IHS 16 YEL
 - 9-WH 14 YEL
 - 10-KE 14 YEL
 - 11-LH 16 YEL
 - 12-
 - 13-LJ 16 YEL
 - 14-JJG 12 YEL
 - 15-KA 12 YEL

- 6 BLK
- J 6 BLK
- BY 8 BLK
- WP 10 YEL
- WH 14 YEL
- KE 14 YEL
- KA 12 YEL
- ER 16 YEL
- JJG 12 YEL
- KKF 6 BLK
- KKG 8 BLK
- LLK 10 YEL
- LLM 10 YEL

- LJ 16 YEL
- LG 16 YEL
- LH 16 YEL
- KKF 6 BLK

- 5 CIRCUIT IS NOT USED.
- 4 WIRE IS FROM WIRE ASM-SLIDEOUT POWER.
- 3 SEE WIRING DIAGRAM-AUTO FOR ADDITIONAL INFORMATION.
- 2 SEE MANUFACTURERS DIAGRAM FOR ADDITIONAL INFORMATION.

1. SPLICES ARE THEORETICAL AND MAY DIFFER IN THE HARNESS.

NOTES:

WINNEBAGO		COPYRIGHT 2006 WINNEBAGO INDUSTRIES, INC.	
DFT	ORIG. DATE		
CHKR	ALL DIMENSIONS ARE IN MILLIMETERS		
P.E.			
M.E.	FIRST USED	07 D29R	
DSNR			
UNSPECIFIED TOLERANCES ARE:		MATERIAL:	
WHOLE DIM (X)	:		
ONE-PLACE (X.X)	:		
TWO-PLACE (X.XX)	:		
ANGLE	:		
THIRD ANGLE PROJECTION			
DO NOT SCALE DRAWING			
TITLE: WIRING DIAGRAM-BODY, 12V			
SHEET 1 of 7	PART NO	158003	REV
REF:		1 9/4/2006	

CONNECTS TO WIRE ASM-SLIDEOUT (SHT 5, D-3) (LOCATED IN FRONT LEFT SLIDEOUT UNDER COUCH)

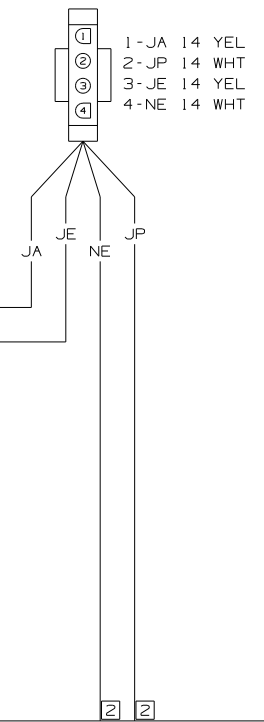

CONNECTS TO GROUND STUD

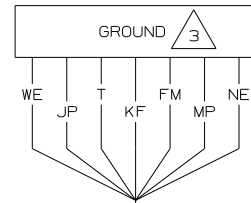

T 6 GRN
KF 16 WHT
FM 14 WHT
MP 16 WHT
WE 14 WHT
JP 14 WHT
NE 14 WHT

CONNECTS TO REAR SLIDEOUT ARM

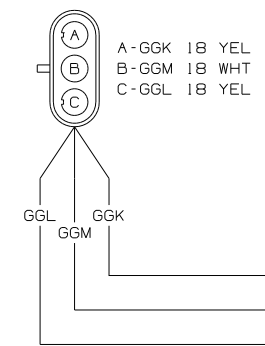

CONNECTS TO SLIDEOUT MODULE (LOCATED IN CHASSIS ELECTRICAL BOX)

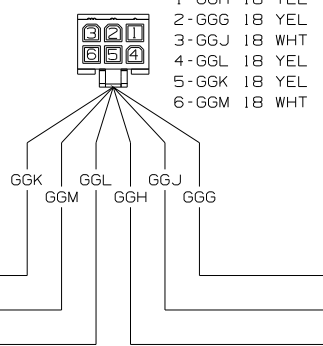

CONNECTS TO FRONT SLIDEOUT ARM

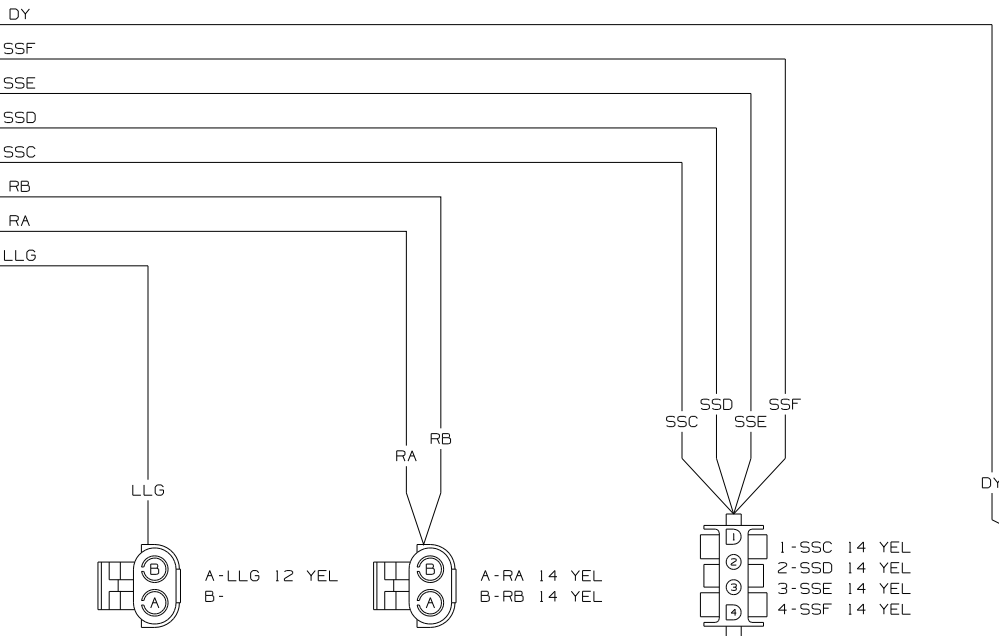
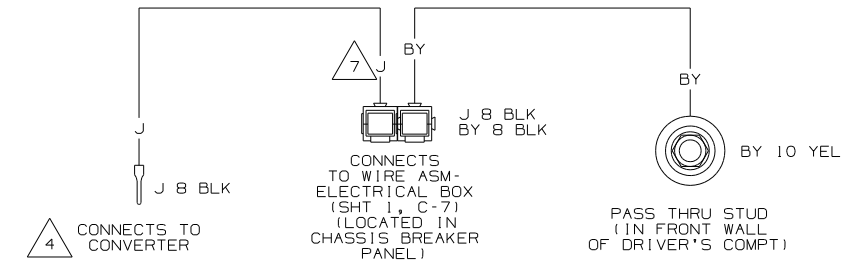
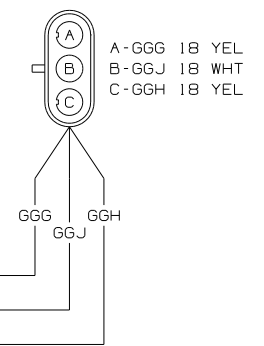

CONNECTS TO WIRE ASM-HEADLAMP

CONNECTS TO WIRE ASM-BACKWALL

CONNECTS TO WIRE ASM-COACH (SHT 3, D-3) (LOCATED UNDER REFRIGERATOR CABT)

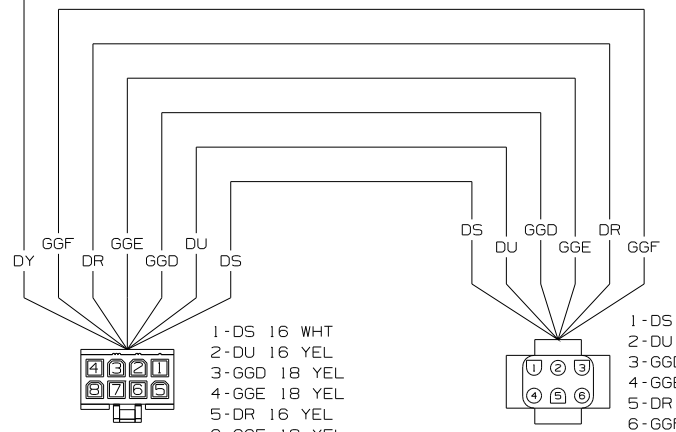

CONNECTS TO SLIDEOUT MODULE (LOCATED IN CHASSIS ELECTRICAL BOX)

CONNECTS TO WIRE ASM-COACH (SHT 3, A-8) (LOCATED UNDER REFRIGERATOR CABT)

WIRING DIAGRAM-CHASSIS (WIRE ASM 158143 REV-A)

FIRST USED	07 D29R
DO NOT SCALE DRAWING	
TITLE	WIRING DIAGRAM-BODY, 12V
SHEET 2	PART NO 158003 REV

D
C
B
A

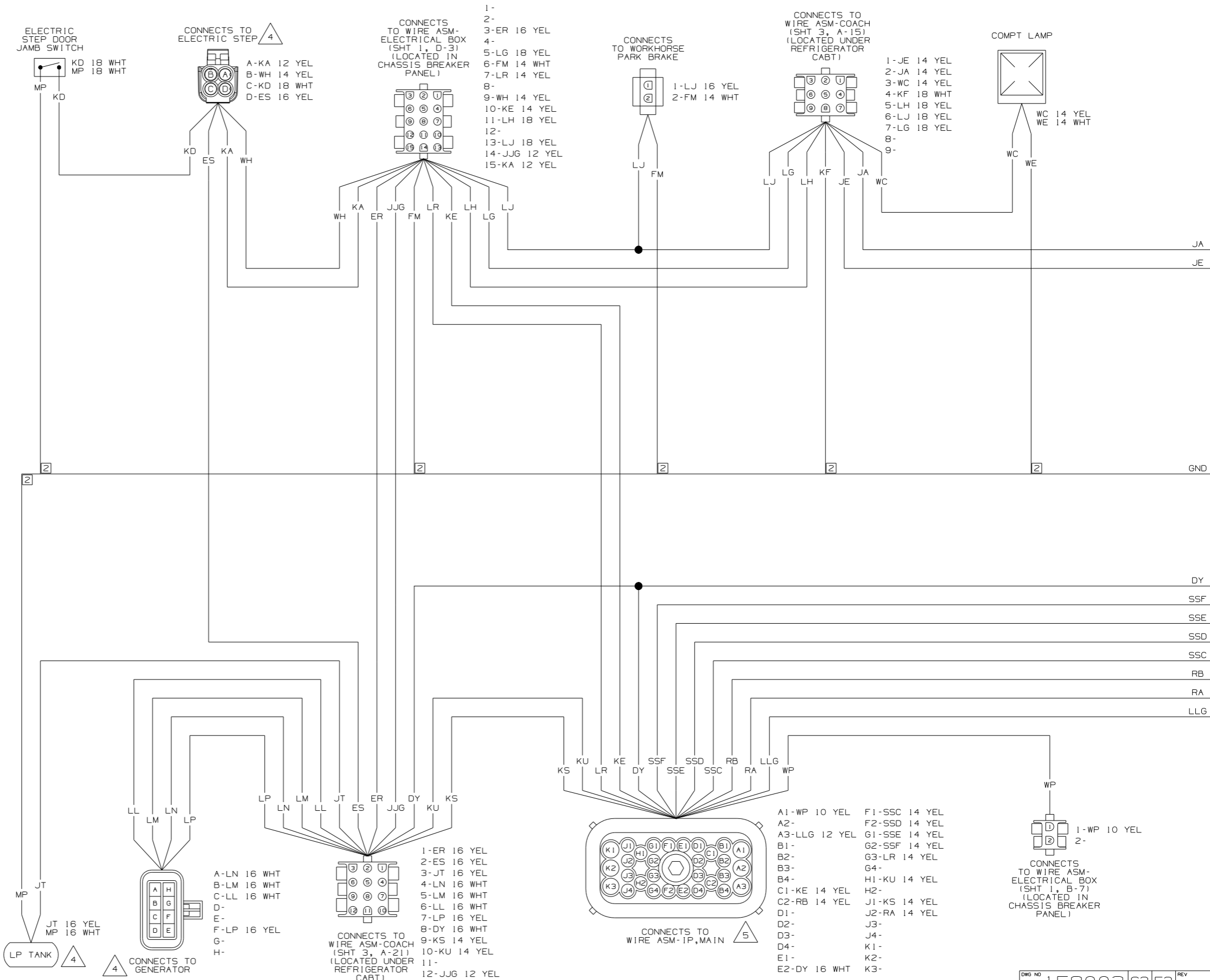

- 7 WIRE IS MARKED WITH YELLOW TAPE.
 - 6 SEE WIRING DIAGRAM-AUTO LAMPS FOR ADDITIONAL INFORMATION.
 - 5 SEE WIRING DIAGRAM-AUTO FOR ADDITIONAL INFORMATION.
 - 4 SEE MANUFACTURERS DIAGRAM FOR ADDITIONAL INFORMATION.
 - 3 GROUNDS ARE SHOWN AS A SINGLE LINE FOR EASE IN TRACING. EACH GROUND CIRCUIT IS SEPERATE IN THE HARNESS.
 - 2 NOT A SPLICE POINT. INDICATES ENTRY INTO WIRING HARNESS.
- NOTES:
 1. SPLICES ARE THEORETICAL AND MAY DIFFER IN THE HARNESS.

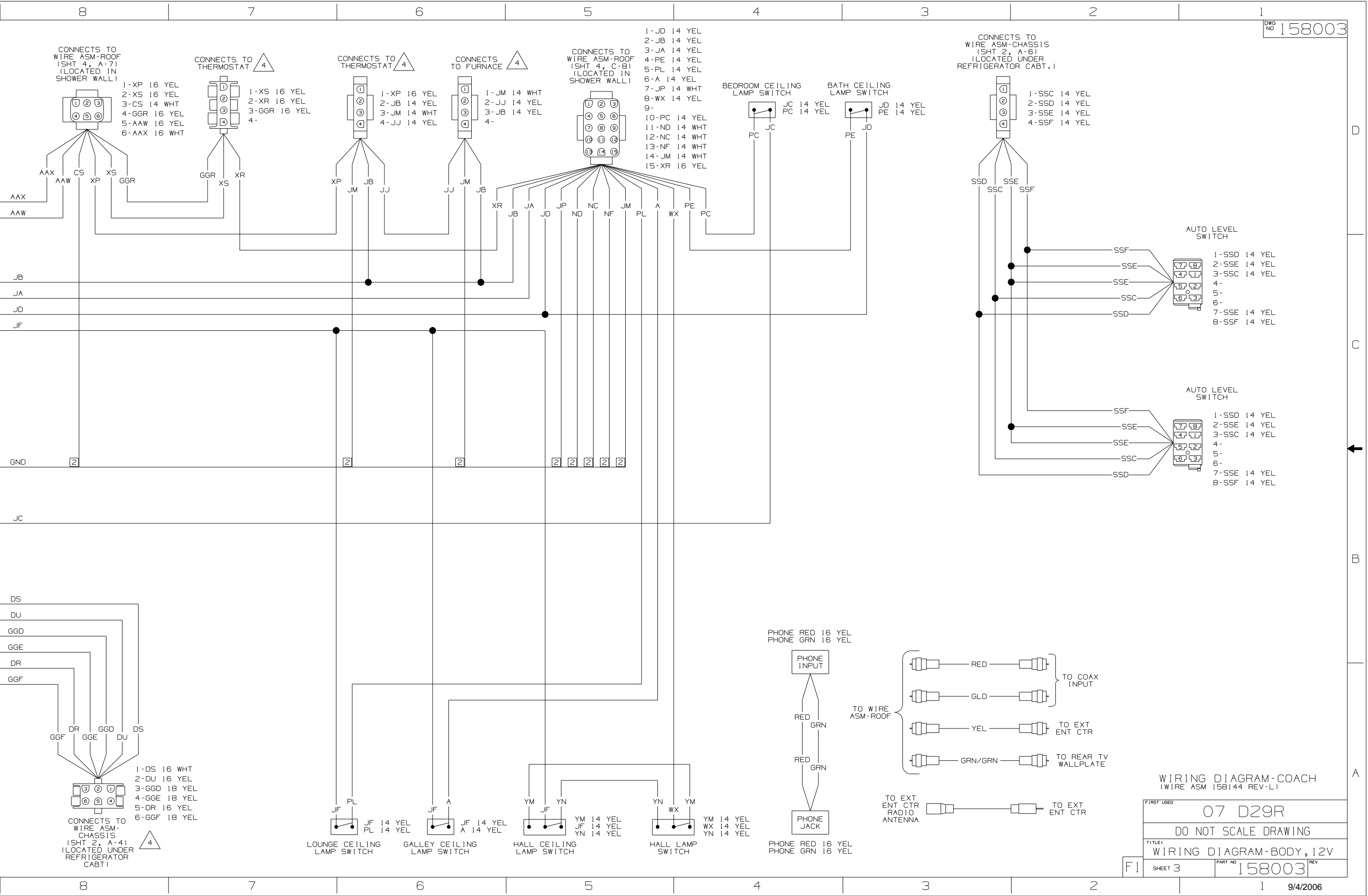

CONNECTS TO WIRE ASM-ROOF (SHT 4, A-7) (LOCATED IN SHOWER WALL)

- 1-XP 16 YEL
- 2-XS 16 YEL
- 3-CS 14 WHT
- 4-GGR 16 YEL
- 5-AAW 16 YEL
- 6-AAW 16 WHT

CONNECTS TO THERMOSTAT

- 1-XS 16 YEL
- 2-XR 16 YEL
- 3-GGR 16 YEL
- 4-

CONNECTS TO THERMOSTAT

- 1-XP 16 YEL
- 2-JB 14 YEL
- 3-JM 14 WHT
- 4-JJ 14 YEL

CONNECTS TO FURNACE

- 1-JM 14 WHT
- 2-JJ 14 YEL
- 3-JB 14 YEL
- 4-

CONNECTS TO WIRE ASM-ROOF (SHT 4, C-8) (LOCATED IN SHOWER WALL)

- 1-JD 14 YEL
- 2-JB 14 YEL
- 3-JA 14 YEL
- 4-PE 14 YEL
- 5-PL 14 YEL
- 6-A 14 YEL
- 7-JP 14 WHT
- 8-WX 14 YEL
- 9-
- 10-PC 14 YEL
- 11-ND 14 WHT
- 12-NC 14 WHT
- 13-NF 14 WHT
- 14-JM 14 WHT
- 15-XR 16 YEL

BEDROOM CEILING LAMP SWITCH

BATH CEILING LAMP SWITCH

CONNECTS TO WIRE ASM-CHASSIS (SHT 2, A-6) (LOCATED UNDER REFRIGERATOR CABT.)

- 1-SSC 14 YEL
- 2-SSD 14 YEL
- 3-SSE 14 YEL
- 4-SSF 14 YEL

AUTO LEVEL SWITCH

- 1-SSD 14 YEL
- 2-SSE 14 YEL
- 3-SSC 14 YEL
- 4-
- 5-
- 6-
- 7-SSE 14 YEL
- 8-SSF 14 YEL

AUTO LEVEL SWITCH

- 1-SSD 14 YEL
- 2-SSE 14 YEL
- 3-SSC 14 YEL
- 4-
- 5-
- 6-
- 7-SSE 14 YEL
- 8-SSF 14 YEL

- DS
- DU
- GGD
- GGE
- DR
- GGF

- 1-DS 16 WHT
- 2-DU 16 YEL
- 3-GGD 18 YEL
- 4-GGE 18 YEL
- 5-DR 16 YEL
- 6-GGF 18 YEL

CONNECTS TO WIRE ASM-CHASSIS (SHT 2, A-4) (LOCATED UNDER REFRIGERATOR CABT)

PHONE RED 16 YEL
PHONE GRN 16 YEL

PHONE INPUT

RED
GRN

RED
GRN

PHONE JACK

PHONE RED 16 YEL
PHONE GRN 16 YEL

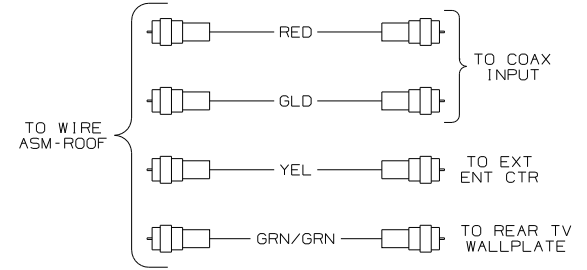

WIRING DIAGRAM-COACH (WIRE ASM 158144 REV-L)

FIRST USED	07 D29R
DO NOT SCALE DRAWING	
TITLE	WIRING DIAGRAM-BODY, 12V
SHEET 3	PART NO 158003

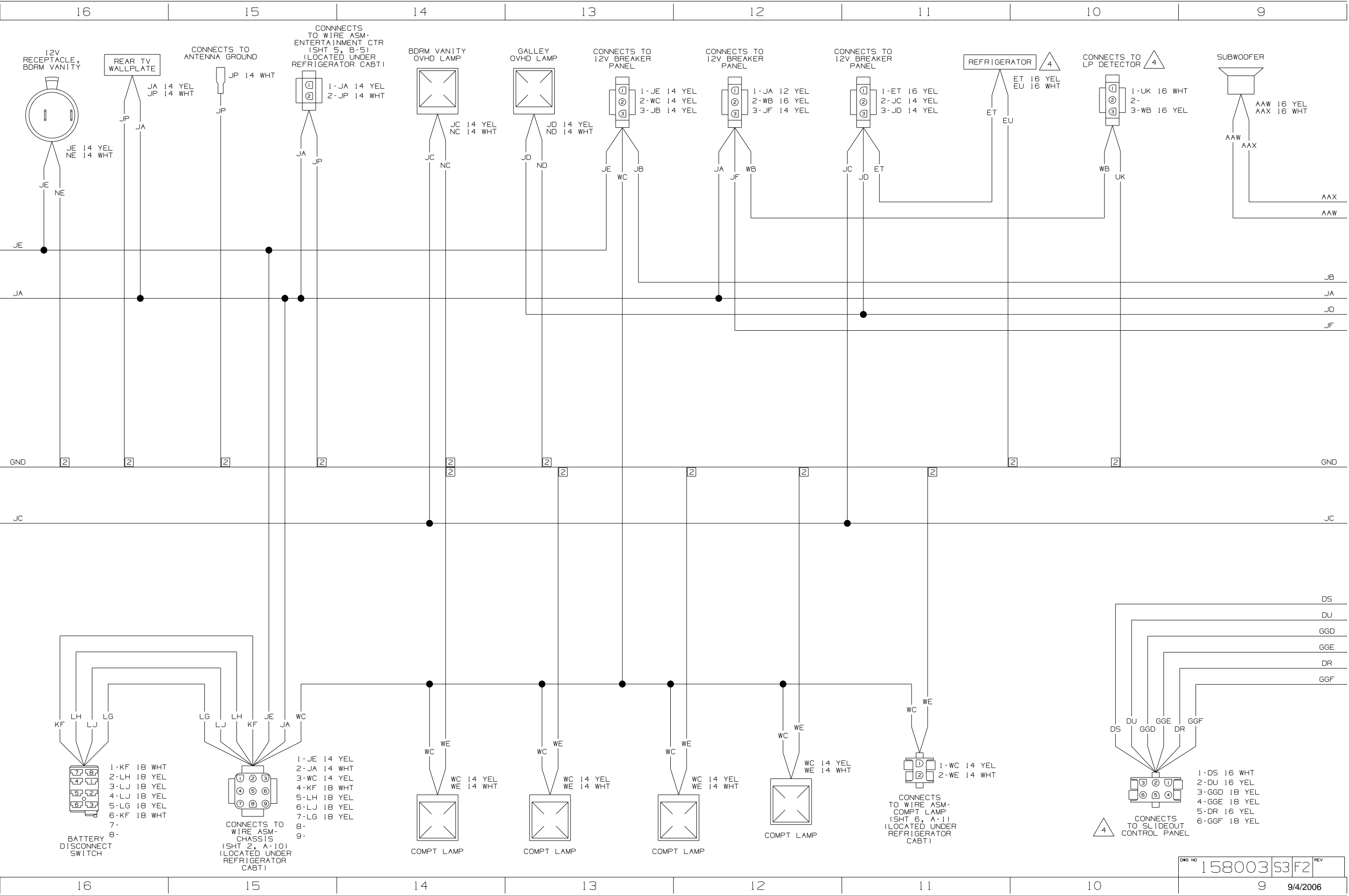

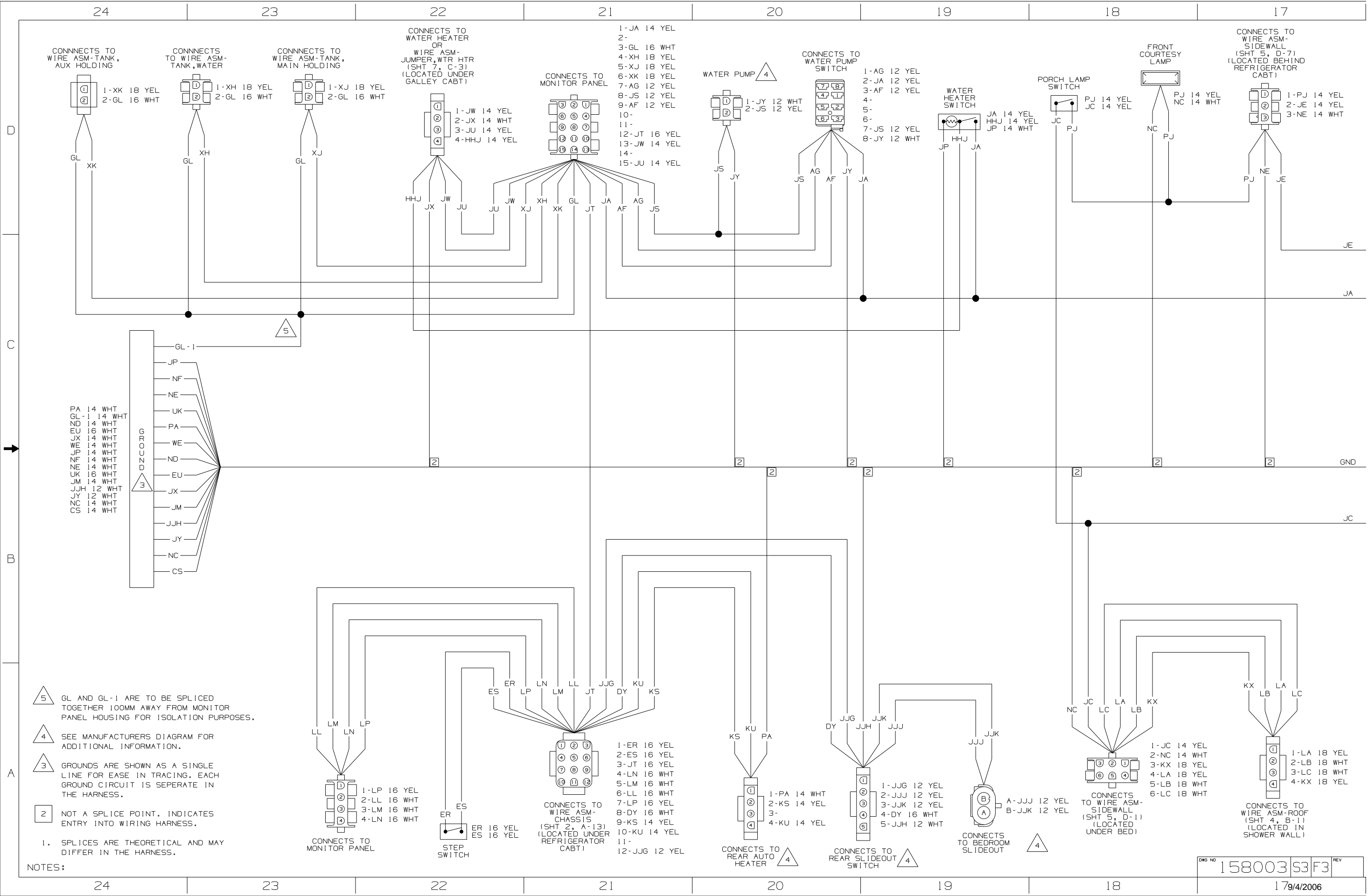

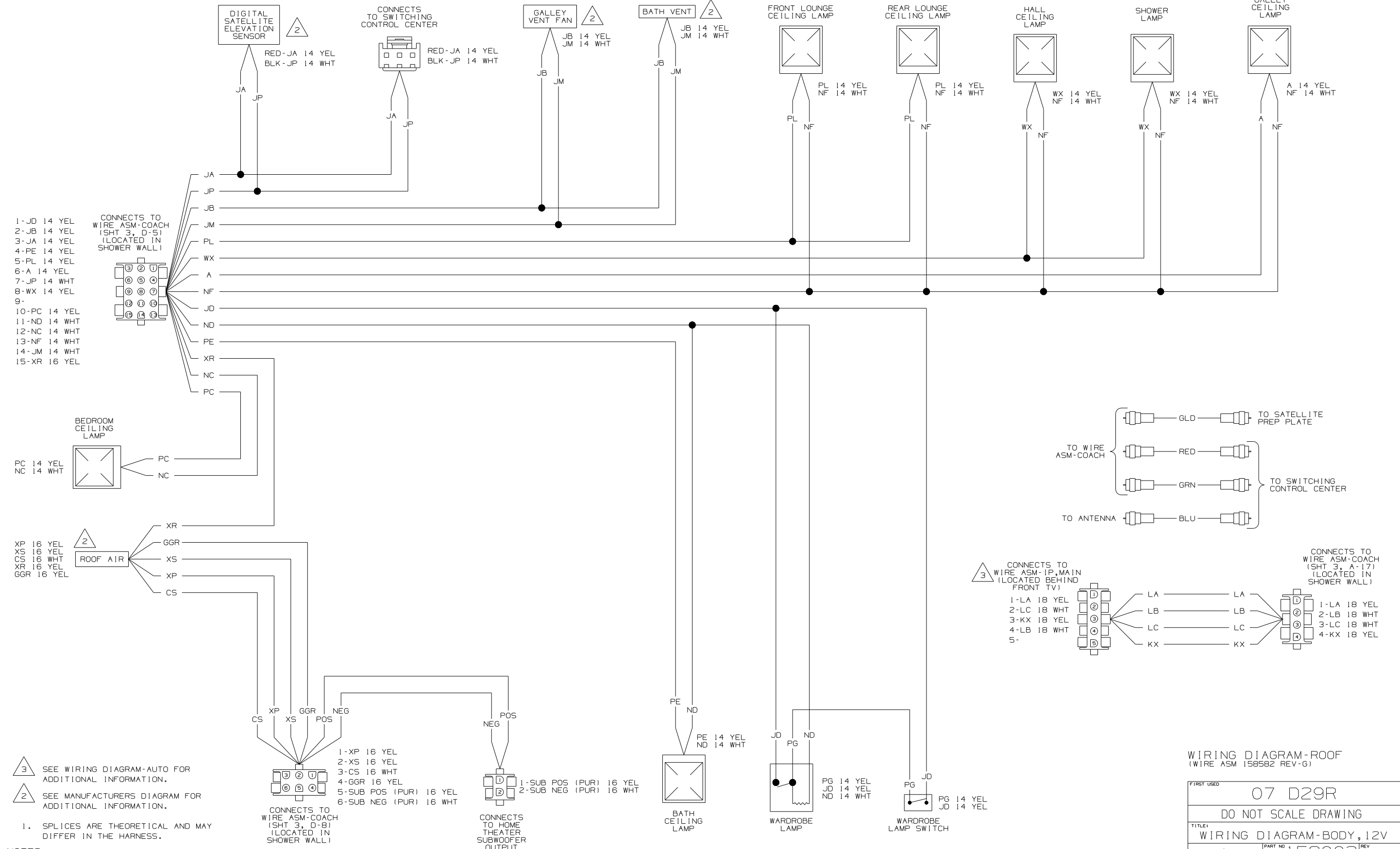

- 1-JD 14 YEL
- 2-JB 14 YEL
- 3-JA 14 YEL
- 4-PE 14 YEL
- 5-PL 14 YEL
- 6-A 14 YEL
- 7-JP 14 WHT
- 8-WX 14 YEL
- 9-
- 10-PC 14 YEL
- 11-ND 14 WHT
- 12-NC 14 WHT
- 13-NF 14 WHT
- 14-JM 14 WHT
- 15-XR 16 YEL

- XP 16 YEL
- XS 16 YEL
- CS 16 WHT
- XR 16 YEL
- GGR 16 YEL

NOTES:

3 SEE WIRING DIAGRAM-AUTO FOR ADDITIONAL INFORMATION.

2 SEE MANUFACTURERS DIAGRAM FOR ADDITIONAL INFORMATION.

1. SPLICES ARE THEORETICAL AND MAY DIFFER IN THE HARNESS.

- 1-XP 16 YEL
- 2-XS 16 YEL
- 3-CS 16 WHT
- 4-GGR 16 YEL
- 5-SUB POS (PUR) 16 YEL
- 6-SUB NEG (PUR) 16 WHT

- 1-LA 18 YEL
- 2-LC 18 WHT
- 3-KX 18 YEL
- 4-LB 18 WHT
- 5-

WIRING DIAGRAM-ROOF
(WIRE ASM 158582 REV-G)

FIRST USED	07 D29R
DO NOT SCALE DRAWING	
TITLE: WIRING DIAGRAM-BODY, 12V	
SHEET 4	PART NO 158003 REV

1 9/4/2006

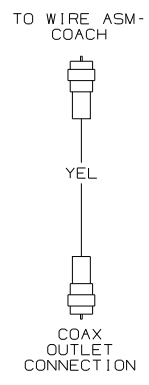

CONNECTS TO WIRE ASM-COACH (SHT 3, D-16) (LOCATED BEHIND REFRIGERATOR CABT)

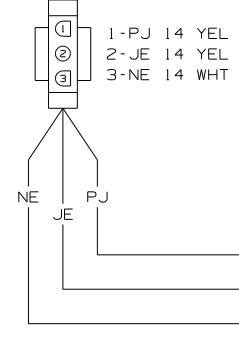

PORCH LAMP

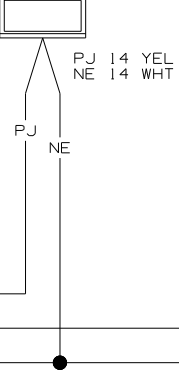

CONNECTS TO WIRE ASM-OVHD (SHT 6, D-17) (LOCATED IN DINETTE OVHD CABT)

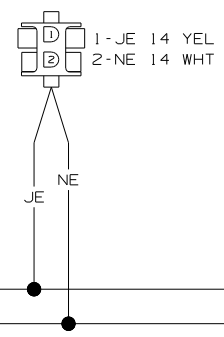

12V RECEPTACLE

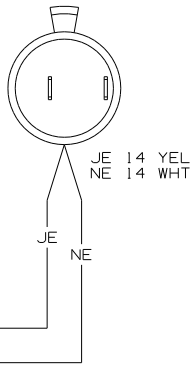

WIRING DIAGRAM-SIDEWALL (WIRE ASM 149486-02 REV-D)

CONNECTS TO WIRE ASM-CHASSIS (SHT 2, D-8) (LOCATED IN FRONT LEFT SLIDEOUT UNDER COUCH)

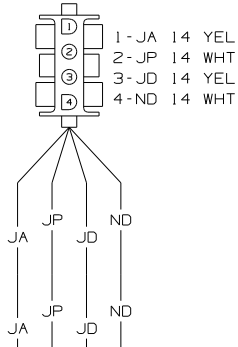

CONNECTS TO WIRE ASM-OVHD (SHT 5, A-2) (LOCATED IN FRONT LEFT OVHD CABT)

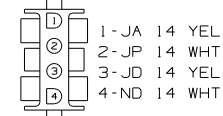

WIRING DIAGRAM-SLIDEOUT (WIRE ASM 149654 REV-B)

CONNECTS TO WIRE ASM-COACH (SHT 3, A-18) (LOCATED UNDER BED)

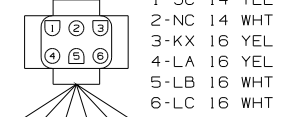

FRONT WALL LAMP

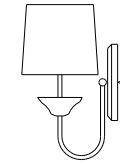

REAR WALL LAMP

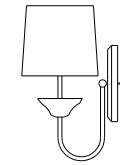

WIRING DIAGRAM-SIDEWALL (WIRE ASM 151325 REV-A)

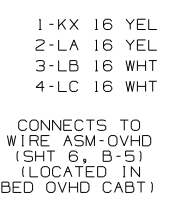

CONNECTS TO WIRE ASM-OVHD (SHT 6, B-5) (LOCATED IN BED OVHD CABT)

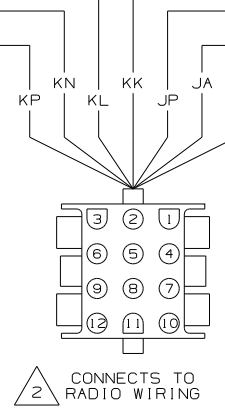
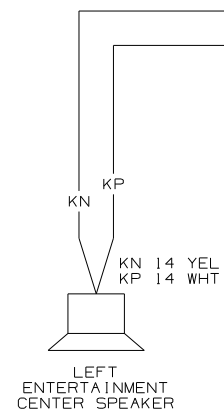
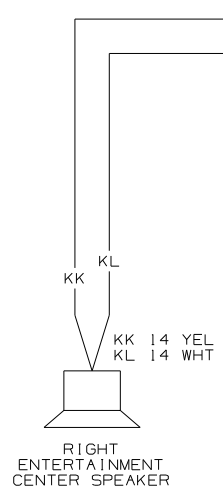

CONNECTS TO RADIO WIRING

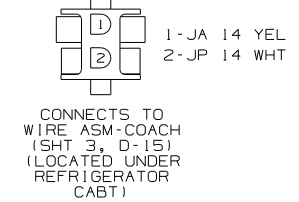

WIRING DIAGRAM-ENTERTAINMENT CTR (WIRE ASM 125853-04 REV-L)

FRONT OVHD READING LAMP

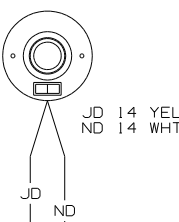

REAR OVHD READING LAMP

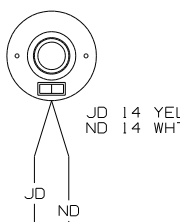

CONNECTS TO WIRE ASM-SLIDEOUT (SHT 5, C-3) (LOCATED IN FRONT LEFT OVHD CABT)

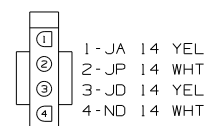

CONNECTS TO RANGE HOOD

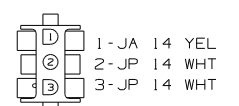

WIRING DIAGRAM-OVHD (WIRE ASM 149485 REV-A)

SEE MANUFACTURERS DIAGRAM FOR ADDITIONAL INFORMATION.

1. SPLICES ARE THEORETICAL AND MAY DIFFER IN THE HARNESS.

NOTES:

FIRST USED	07 D29R
TITLE	DO NOT SCALE DRAWING
TITLE	WIRING DIAGRAM-BODY, 12V
SHEET 5	PART NO 158003 REV

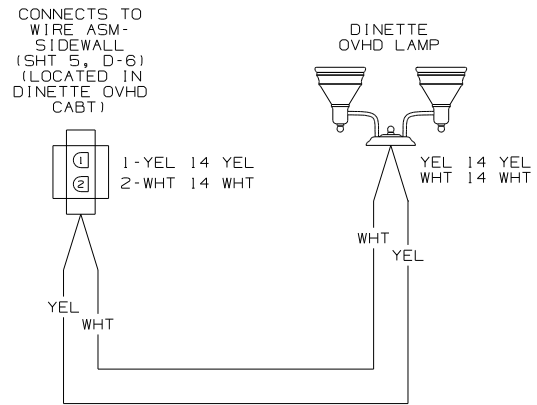

WIRING DIAGRAM-OVHD
(WIRE ASM 133572 REV-F)

- CONNECTS TO HOME THEATER AMPLIFIER
- 1-RT FRT POS (RED) 18 YEL
 - 2-RT FRT NEG (RED) 18 WHT
 - 3-CENTER POS (GRN) 18 YEL
 - 4-CENTER NEG (GRN) 18 WHT
 - 5-LT FRT POS (WHT) 18 YEL
 - 6-LT FRT NEG (WHT) 18 WHT
 - 7-RT RR POS (GRY) 18 YEL
 - 8-RT RR NEG (GRY) 18 WHT
 - 9-LT RR POS (BLU) 18 YEL
 - 10-LT RR NEG (BLU) 18 WHT
 - 11-SUB POS 16 Y
 - 12-SUB NEG 16 W

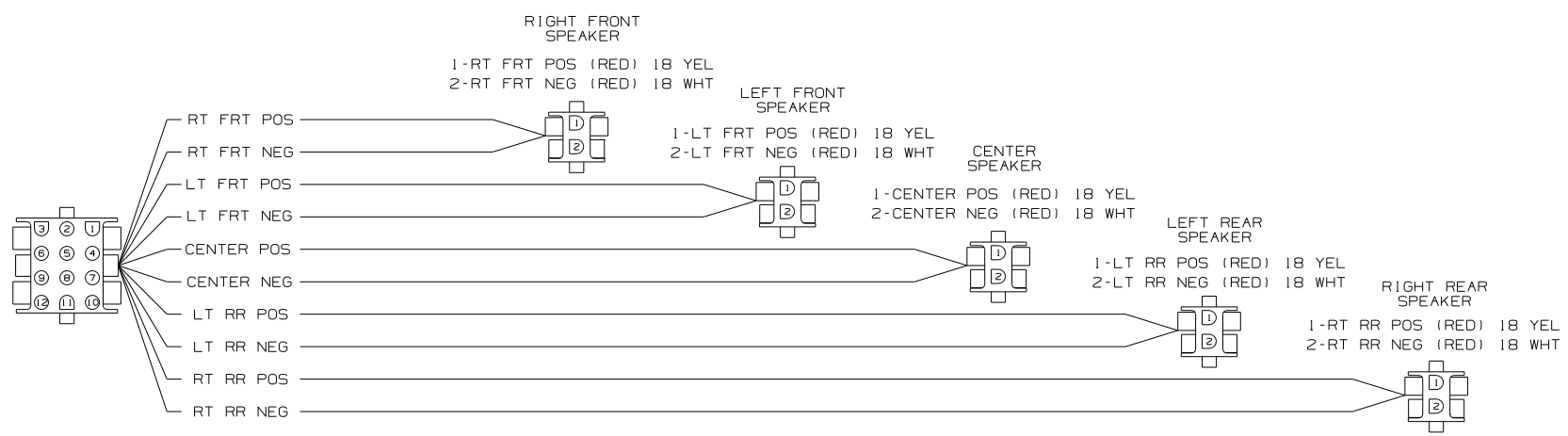

WIRING DIAGRAM-HOME THEATER EXT
(WIRE ASM 159963 REV-A)

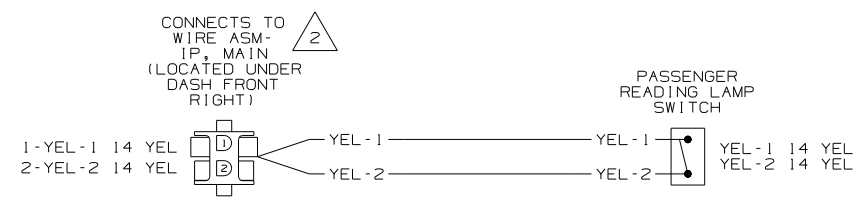

WIRING DIAGRAM-EXTENSION, 2 PIN
(WIRE ASM 147579-02 REV-A)

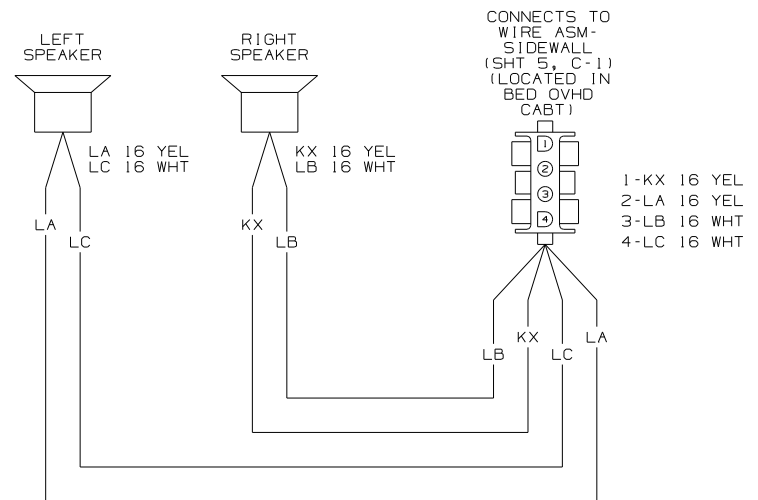

WIRING DIAGRAM-OVHD
(WIRE ASM 151307 REV-A)

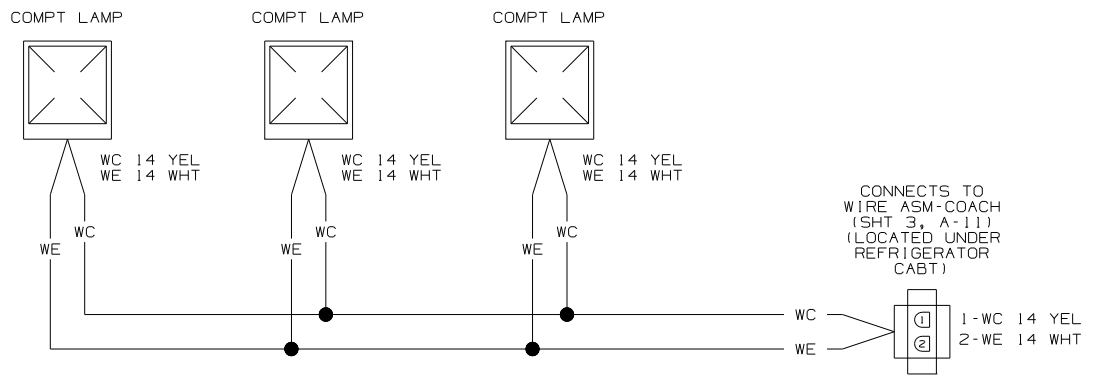

WIRING DIAGRAM-COMPT LAMP
(WIRE ASM 149929 REV-C)

SEE WIRING DIAGRAM-AUTO FOR ADDITIONAL INFORMATION.

1. SPLICES ARE THEORETICAL AND MAY DIFFER IN THE HARNESS.

NOTES:

FIRST USED	07 D29R
TITLE	DO NOT SCALE DRAWING
	WIRING DIAGRAM-BODY, 12V
SHEET 6	PART NO 158003 REV

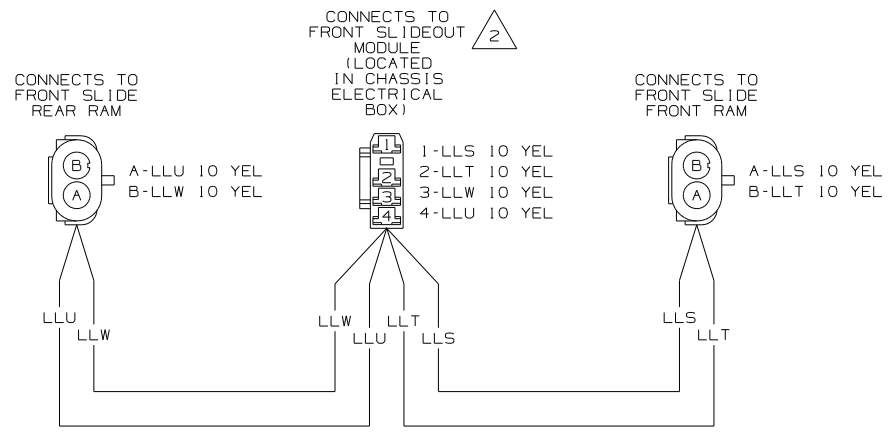

WIRING DIAGRAM-SLIDEOUT RAMS,FRONT
(WIRE ASM 149553-03 REV-L)

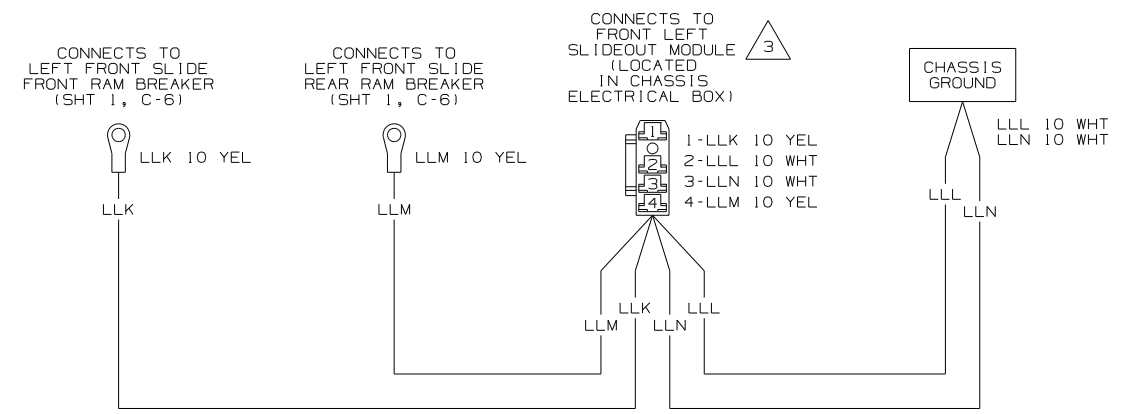

WIRING DIAGRAM-SLIDEOUT POWER
(WIRE ASM 149552-04 REV-N)

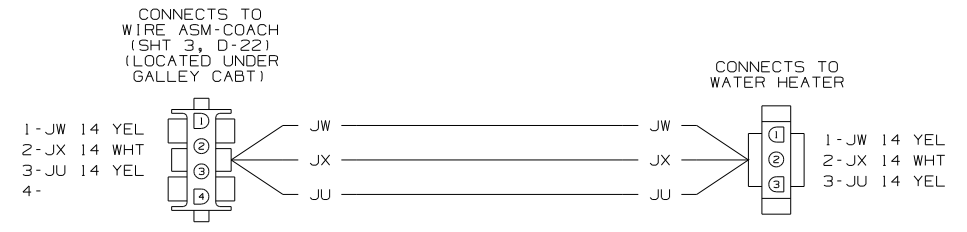

WIRING DIAGRAM-JUMPER,WTR HTR
(WIRE ASM 142263 REV-A)

SEE MANUFACTURER'S DIAGRAM FOR ADDITIONAL INFORMATION.

- 1. SPLICES ARE THEORETICAL AND MAY DIFFER IN THE HARNESS.

NOTES:

FIRST USED	07 D29R	
TITLE	DO NOT SCALE DRAWING	
	WIRING DIAGRAM-BODY, 12V	
SHEET 7	PART NO 158003	REV