



**DANGER**

**Danger of electrical shock, burns or death.** Always remove all power sources before attempting any repair, service or diagnostic work. Power can be present from shore power, generator, inverter or battery. All power sources must be disabled and secured before performing any service.



**CAUTION**

If you lack the skills, tools or equipment to perform diagnostic or repair work leave such work to an authorized Winnebago Industries dealer or other qualified shop.

DRAWING NO.	FEATURE
157961-01	-----
157961-11	(1B1) (12D)
157961-15	(265) (12D)

RELEASE	REV DATE	DWG NO	157961
REV ZONE	REVISION RECORD	DATE	DFTR-0R16

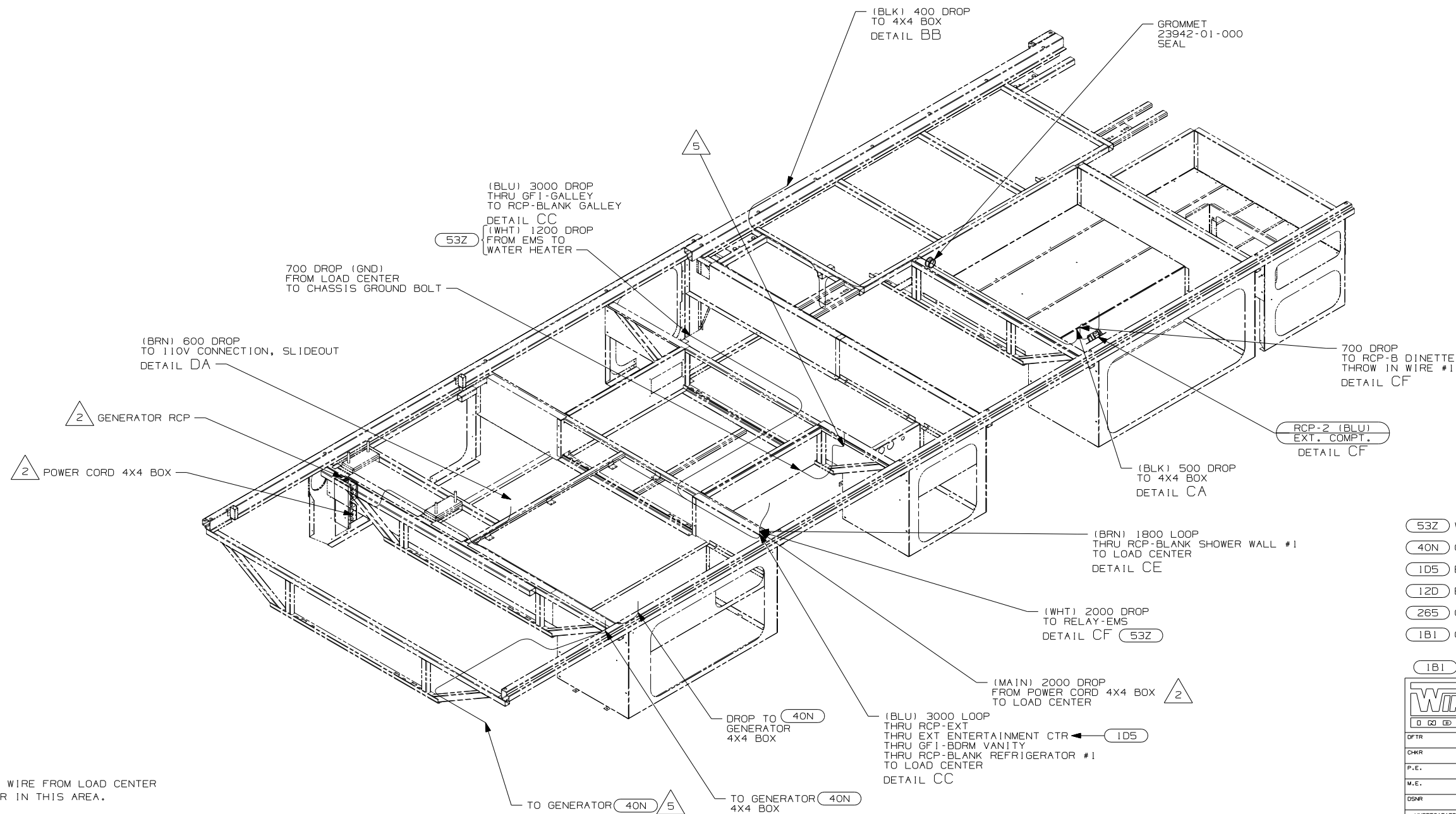

- (53Z) WTR HTR-6GAL/110/LP/MTR/AUTO
- (40N) GEN-4.0KW-ONANGAS-MICROQUIET
- (1D5) ENTERTAINMENT CENTR/EXT W/CD
- (12D) ELECTRICAL SYSTEM 30 AMP
- (265) CODES/STANDARDS-CSA/CMVSS
- (1B1) CODES/STANDARDS USA

(1B1) (265) (12D)

**WINNEBAGO** COPYRIGHT 2006 WINNEBAGO INDUSTRIES, INC.

DFTR	ORIG. DATE
CHKR	ALL DIMENSIONS ARE IN MILLIMETERS
P.E.	
M.E.	FIRST USED
DSNR	07 D29R

UNSPECIFIED TOLERANCES ARE: MATERIAL:

WHOLE DIM (X)	: 3
ONE-PLACE (X.X)	: 1.5
TWO-PLACE (X.XX)	: 0.50
ANGLE	: 1°

THIRD ANGLE PROJECTION

- 5 ROUTE GROUND WIRE FROM LOAD CENTER THROUGH FLOOR IN THIS AREA.
4. ALL WIRES TO BE SECURED WITH CLAMP 10495 OR 10497 OR WIRE TIE 8343 OR 108046 EVERY 600MM, USE SCREW G67-XX-XXX OR G56-XX-XXX AS APPROPRIATE FOR INSTALLATION.
- 3 WIRE IN SIDEWALL.
- 2 SEE LOAD CENTER/ATS FOR ADDITIONAL INFORMATION.
1. WIRES ROUTED UNDER FLOOR.

FOR ELECTRICAL TORQUE SPECIFICATIONS SEE DWG NO. 128783-01-000

(X-X) FOR ELECTRICAL CALLOUTS SEE DWG NO. 121339-01-000

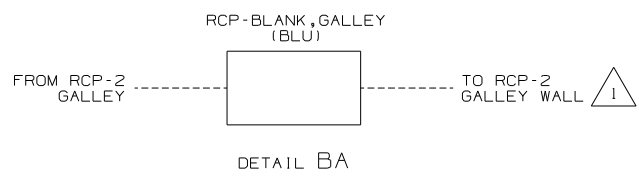

- 1 1B1 RCP-1 (BLK) MICROWAVE
- 1 265 RCP-5 (BLK) MICROWAVE

1 SP-04 RCP-2 (BLU) GALLEY WALL

53Z WHT WIRE TO WATER HEATER

1 SP-04 RCP-2 (BLU) BATH WALL

1 SP-04 RCP-2 (BRN) BDRM, FRONT

1 SP-04 RCP-2 (BRN) BDRM, REAR

SLIDEOUT WIRE #1 (BLK) (FROM 4X4 BOX BEHIND DINETTE SEAT) DETAIL CA

4X4 BOX DETAIL BB

RCP-2 (BLU) GALLEY

RCP-B (DET BA) GALLEY

110V CONNECTIONS DETAIL DA

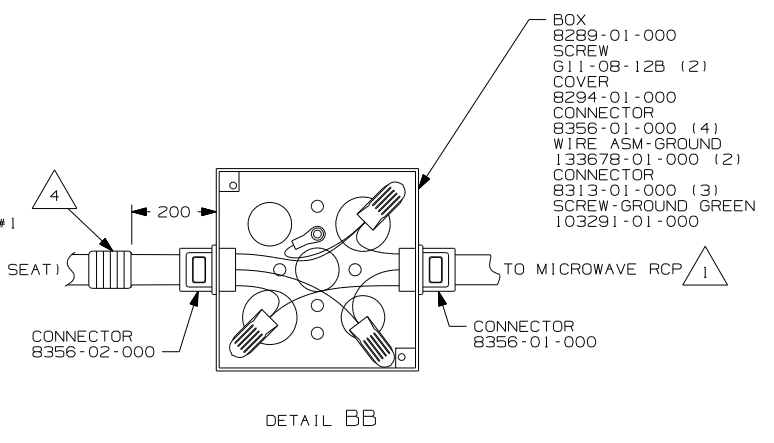

4 APPLY 300 MM OF CONDUIT-COVOLUTE 41953-05-000 OVER WIRE AT DIMENSION SHOWN AND SECURE BOTH END OF TUBING TO WIRE WITH TAPE 8363-01-000.

3. ALL WIRES TO BE SECURED WITH CLAMP 10495 OR 10497 OR WIRE TIE 8343 OR 108046 EVERY 600MM, USE SCREW G67-XX-XXX OR G56-XX-XXX AS APPROPRIATE FOR INSTALLATION.

2 WIRE ROUTED THRU FLOOR IN THIS AREA.

1 WIRE ROUTED IN SIDEWALL.

NOTES:

- 53Z WTR HTR-6GAL/110V/LP/MTR/AUTO
- 12D ELECTRICAL SYSTEM 30 AMP
- 265 CODES/STANDARDS-CSA/CMVSS
- 1B1 CODES/STANDARDS USA

1B1 265 12D

FOR ELECTRICAL TORQUE SPECIFICATIONS SEE DWG NO. 128783-01-000

FOR ELECTRICAL CALLOUTS SEE DWG NO. 121339-01-000

FIRST USED	
07 D29R	
DO NOT SCALE DRAWING	
TITLE: WIRING INSTL-BODY, 110V	
SHEET 2	PART NO 157961

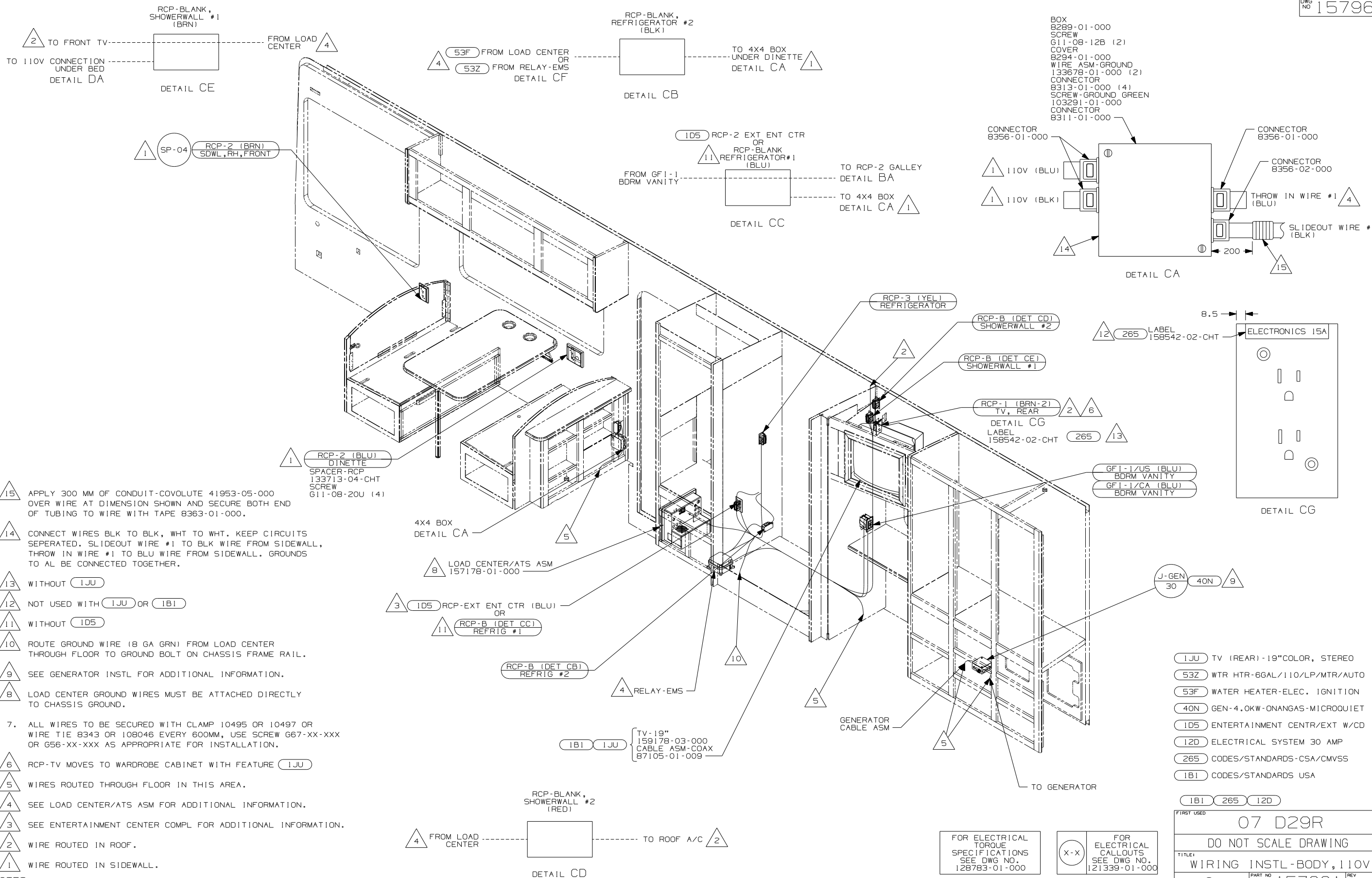

- BOX 8289-01-000
- SCREW 611-08-12B (2)
- COVER 8294-01-000
- WIRE ASM-GROUND 133678-01-000 (2)
- CONNECTOR 8313-01-000 (4)
- SCREW-GROUND GREEN 103291-01-000
- CONNECTOR 8311-01-000

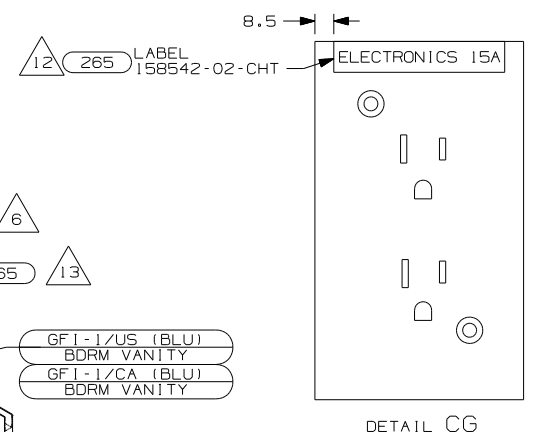
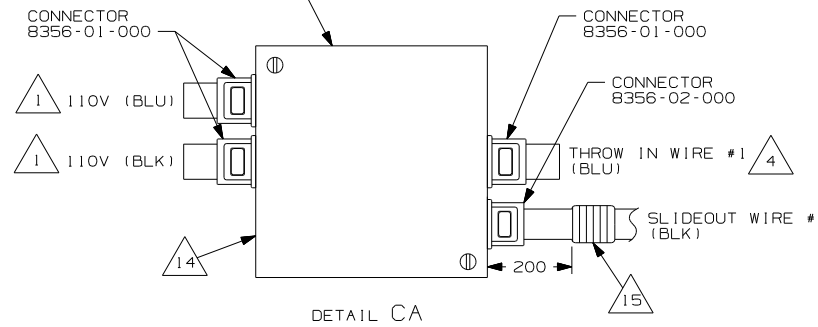

- NOTES:
- 15 APPLY 300 MM OF CONDUIT-COVOLUTE 41953-05-000 OVER WIRE AT DIMENSION SHOWN AND SECURE BOTH END OF TUBING TO WIRE WITH TAPE 8363-01-000.
  - 14 CONNECT WIRES BLK TO BLK, WHT TO WHT. KEEP CIRCUITS SEPERATED. SLIDEOUT WIRE #1 TO BLK WIRE FROM SIDEWALL, THROW IN WIRE #1 TO BLU WIRE FROM SIDEWALL. GROUNDS TO AL BE CONNECTED TOGETHER.
  - 13 WITHOUT 1JU
  - 12 NOT USED WITH 1JU OR 1B1
  - 11 WITHOUT 1D5
  - 10 ROUTE GROUND WIRE (8 GA GRN) FROM LOAD CENTER THROUGH FLOOR TO GROUND BOLT ON CHASSIS FRAME RAIL.
  - 9 SEE GENERATOR INSTL FOR ADDITIONAL INFORMATION.
  - 8 LOAD CENTER GROUND WIRES MUST BE ATTACHED DIRECTLY TO CHASSIS GROUND.
  - 7. ALL WIRES TO BE SECURED WITH CLAMP 10495 OR 10497 OR WIRE TIE 8343 OR 108046 EVERY 600MM, USE SCREW G67-XX-XXX OR G56-XX-XXX AS APPROPRIATE FOR INSTALLATION.
  - 6 RCP-TV MOVES TO WARDROBE CABINET WITH FEATURE 1JU
  - 5 WIRES ROUTED THROUGH FLOOR IN THIS AREA.
  - 4 SEE LOAD CENTER/ATS ASM FOR ADDITIONAL INFORMATION.
  - 3 SEE ENTERTAINMENT CENTER COMPL FOR ADDITIONAL INFORMATION.
  - 2 WIRE ROUTED IN ROOF.
  - 1 WIRE ROUTED IN SIDEWALL.

- 1JU TV (REAR)-19"COLOR, STEREO
- 53Z WTR HTR-6GAL/110/LP/MTR/AUTO
- 53F WATER HEATER-ELEC. IGNITION
- 40N GEN-4.0KW-ONANGAS-MICROQUIET
- 1D5 ENTERTAINMENT CENTR/EXT W/CD
- 12D ELECTRICAL SYSTEM 30 AMP
- 265 CODES/STANDARDS-CSA/CMVSS
- 1B1 CODES/STANDARDS USA

FOR ELECTRICAL TORQUE SPECIFICATIONS SEE DWG NO. 128783-01-000

FOR ELECTRICAL CALLOUTS SEE DWG NO. 121339-01-000

FIRST USED	07 D29R
TITLE	DO NOT SCALE DRAWING
	WIRING INSTL-BODY, 110V
SHEET 3	PART NO 157961 REV

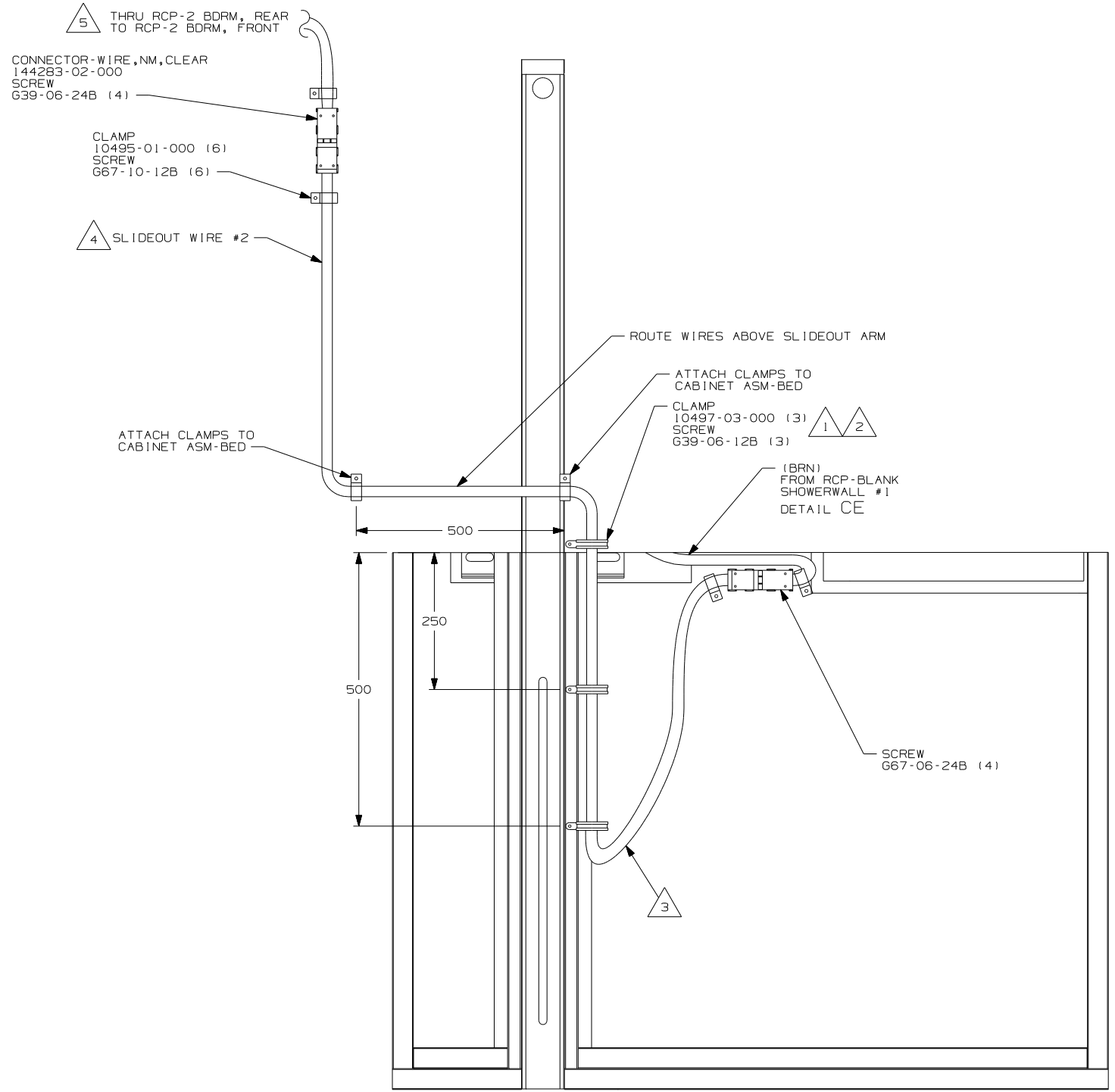

DETAIL DA

- NOTES:
- 5 WIRE ROUTED IN SIDEWALL.
  - 4 FOR MORE INFORMATION SEE LOAD CENTER/ATS ASM.
  - 3 MAKE THE LOOP AS SMALL AS POSSIBLE WHEN SLIDEOUT IS COMPLETELY RETRACTED.
  - 2 RUN 12V WIRE ALONG WITH SLIDEOUT WIRE #2.
  - 1 WIRE MUST BE ROUTED THROUGH CLAMPS AS SHOWN.

265 CODES/STANDARDS-CSA/CMVSS

1B1 CODES/STANDARDS USA

1B1 265

FIRST USED 07 D29R

DO NOT SCALE DRAWING

TITLE: WIRING INSTL-BODY, 110V

SHEET 4 PART NO 157961 REV

FOR ELECTRICAL TORQUE SPECIFICATIONS SEE DWG NO. 128783-01-000

(X-X) FOR ELECTRICAL CALLOUTS SEE DWG NO. 121339-01-000