



DANGER

Danger of electrical shock, burns or death. Always remove all power sources before attempting any repair, service or diagnostic work. Power can be present from shore power, generator, inverter or battery. All power sources must be disabled and secured before performing any service.



CAUTION

If you lack the skills, tools or equipment to perform diagnostic or repair work leave such work to an authorized Winnebago Industries dealer or other qualified shop.

DRAWING NO.	FEATURES	SHEETS
157362-01	(12X)	1, 2
157362-02	(22W)	1, 3
157362-03	(644)	1, 4

RELEASE REV DATE A
 REV ZONE REVISION RECORD DATE DFR-019
 DWG NO 157362

		222B	224V	226A	228P	229T	231C
CABLE ASM-STARTER (RED)	(16B) (16C) (16E)	141415-34-056	141415-34-048	141415-34-046	141415-34-056	141415-34-056	141415-34-053
	(1PY)	-----	141415-34-025	141415-34-029	141415-34-029	141415-34-029	141415-34-036
CABLE ASM-COACH BATTERY (YEL)	(16B) (16C) (16E)	141415-52-016	141415-52-012	141415-52-008	141415-52-021	141415-52-021	141415-52-016
	(1PY)	-----	141415-52-012	141415-52-008	141415-52-021	141415-52-021	141415-52-016
CABLE ASM-COACH BATTERY GND (BLK)	(16B) (16C) (16E)	133566-12-008	133566-12-007	133566-12-010	133566-12-007	133566-12-008	133566-12-008
	(1PY)	-----	133566-12-007	133566-12-010	133566-12-007	133566-12-008	133566-12-008
CABLE ASM-GENERATOR (GRN)	(16B) (16C) (16E)	141415-42-032	141415-42-032	141415-42-038	141415-42-036	141415-42-064	141415-42-068
	(1PY)	-----	141415-42-032	141415-42-038	141415-42-036	141415-42-064	141415-42-068
CABLE ASM-GENERATOR GND (BLK)	(16B) (16C) (16E)	133566-11-008	133566-11-008	133566-11-008	133566-11-008	133566-11-008	133566-11-008
	(1PY)	-----	133566-11-008	133566-11-008	133566-11-008	133566-11-008	133566-11-008

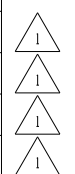

		325F	327L	329B	331C	331H
CABLE ASM-STARTER (RED)	(16E)	141415-34-056	141415-34-056	141415-34-056	141415-34-049	141415-34-052
	(1PY)	141415-34-030	141415-34-029	141415-34-029	141415-34-032	-----
CABLE ASM-COACH BATTERY (YEL)	(16E)	141415-52-017	141415-52-009	141415-52-021	141415-52-016	141415-52-022
	(1PY)	141415-52-017	141415-52-009	141415-52-021	141415-52-016	-----
CABLE ASM-COACH BATTERY GND (BLK)	(16E)	133566-12-007	133566-12-006	133566-12-007	133566-12-006	133566-12-008
	(1PY)	133566-12-007	133566-12-006	133566-12-007	133566-12-006	-----
CABLE ASM-GENERATOR (GRN)	(16E)	141415-42-031	141415-42-067	141415-42-044	141415-42-068	141415-42-078
	(1PY)	141415-42-031	141415-42-067	141415-42-044	141415-42-068	-----
CABLE ASM-GENERATOR GND (BLK)	(16E)	133566-11-008	133566-11-008	133566-11-008	133566-11-008	133566-11-008
	(1PY)	133566-11-008	133566-11-008	133566-11-008	133566-11-008	-----

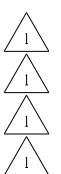

- (644) GREAT ALASKAN RENTAL PACKAGE
- (22W) BATTERY-SECOND
- (12X) BATTERY-ONE
- (1PY) CHEVY CHASSIS 14,050 LB GVWR
- (16E) FORD CHASSIS 14,050 LB.GVWR
- (16C) FORD CHASSIS 11,500 LB.GVWR
- (16B) FORD CHASSIS 10,700 LB.GVWR
- (265) CODES/STANDARDS-CSA/CMVSS
- (1B1) CODES/STANDARDS USA

(1B1) (265)

WINNEBAGO INDUSTRIES, INC. COPYRIGHT 2006

DFTR ORIG. DATE
 CHKR P.E. ALL DIMENSIONS ARE IN MILLIMETERS
 M.E. FIRST USED
 DSNR 07 200/300 SER

UNSPECIFIED TOLERANCES ARE: MATERIAL:
 WHOLE DIM (X) :
 ONE-PLACE (X.X) :
 TWO-PLACE (X.XX) :
 ANGLE :
 THIRD ANGLE PROJECTION

DO NOT SCALE DRAWING

TITLE: BATTERY INSTL

SHEET 1 of 4 PART NO 157362 REV
 REF: 1 5/15/2007

NOTES:
 1 ROUTING OF CABLES SHOWN ON WIRING INSTL-CHASSIS ONLY.

FOR ELECTRICAL TORQUE SPECIFICATIONS SEE DWG NO. 128783-01-000

FOR ELECTRICAL CALLOUTS SEE DWG NO. 121339-01-000

TO GROUND BAR
BOLT
C26-05-16B
NUT
D39-05-00B

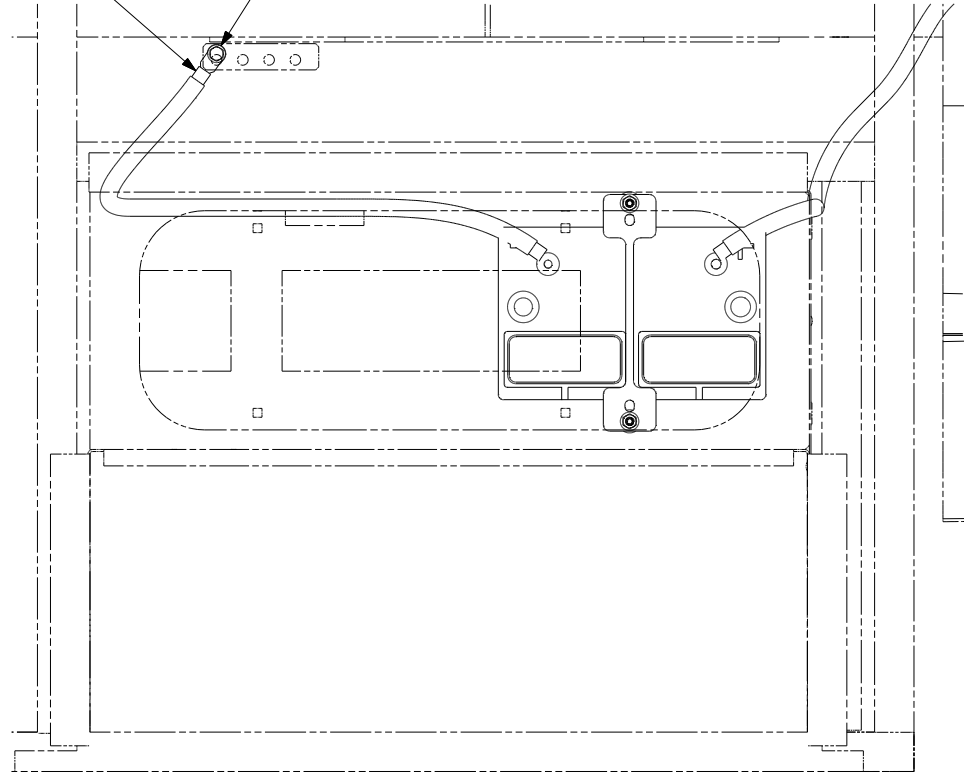

VIEW BA

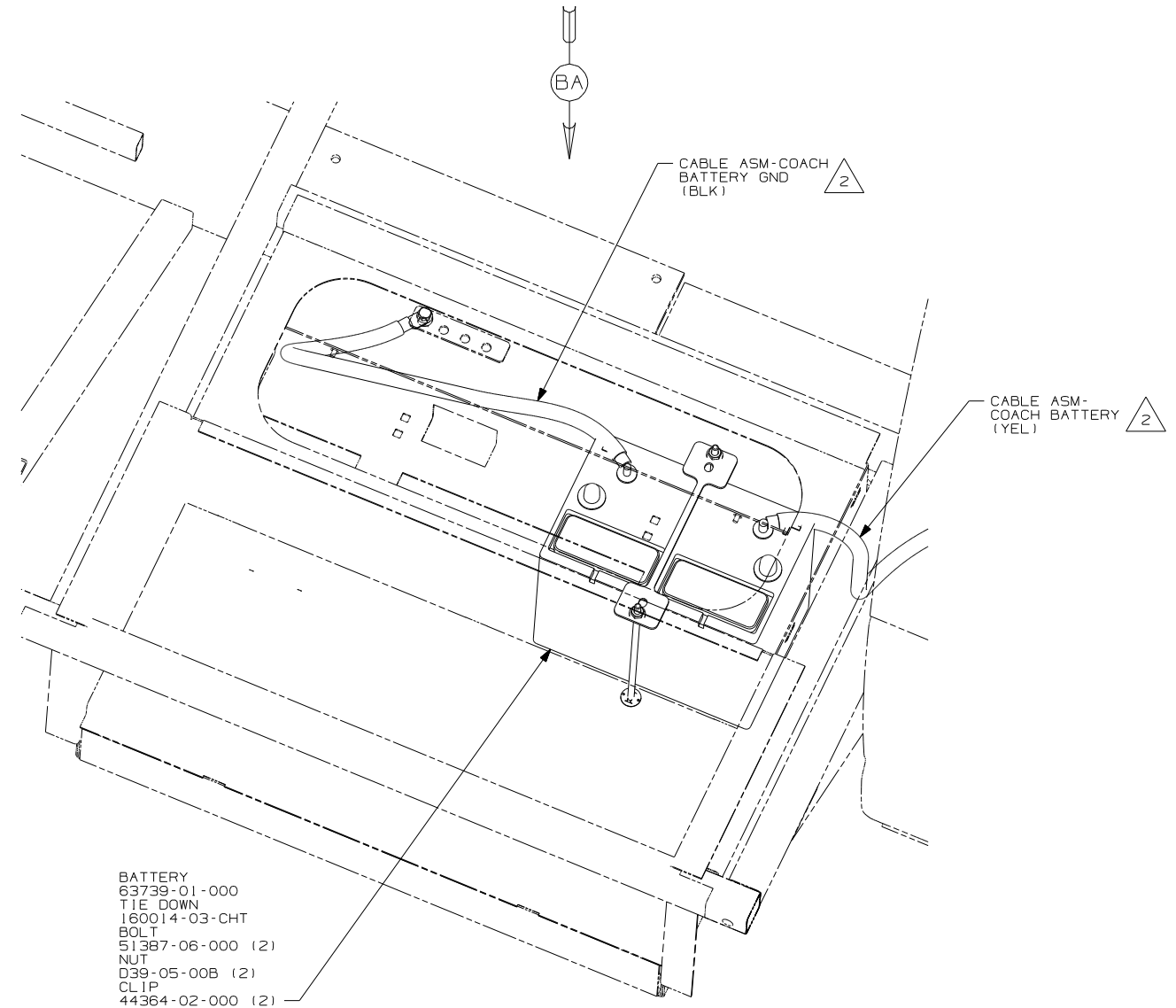

BATTERY
63739-01-000
TIE DOWN
160014-03-CHT
BOLT
51387-06-000 (2)
NUT
D39-05-00B (2)
CLIP
44364-02-000 (2)

BATTERY BOX

- (12X) BATTERY-ONE
- (265) CODES/STANDARDS-CSA/CMVSS
- (1B1) CODES/STANDARDS USA

(1B1) (265) (12X)

FIRST USED	07 200/300 SER
TITLE	DO NOT SCALE DRAWING
TITLE	BATTERY INSTL
SHEET 2	PART NO 157362
REV	

FOR ELECTRICAL TORQUE SPECIFICATIONS SEE DWG NO. 128783-01-000

FOR ELECTRICAL CALLOUTS SEE DWG NO. 121339-01-000

△ BATTERY CABLES ARE NOT TO BE ROUTED OVER BATTERY FILL CAPS.

1. SEE WIRING INSTL-CHASSIS FOR ADDITIONAL INFORMATION.

NOTES:

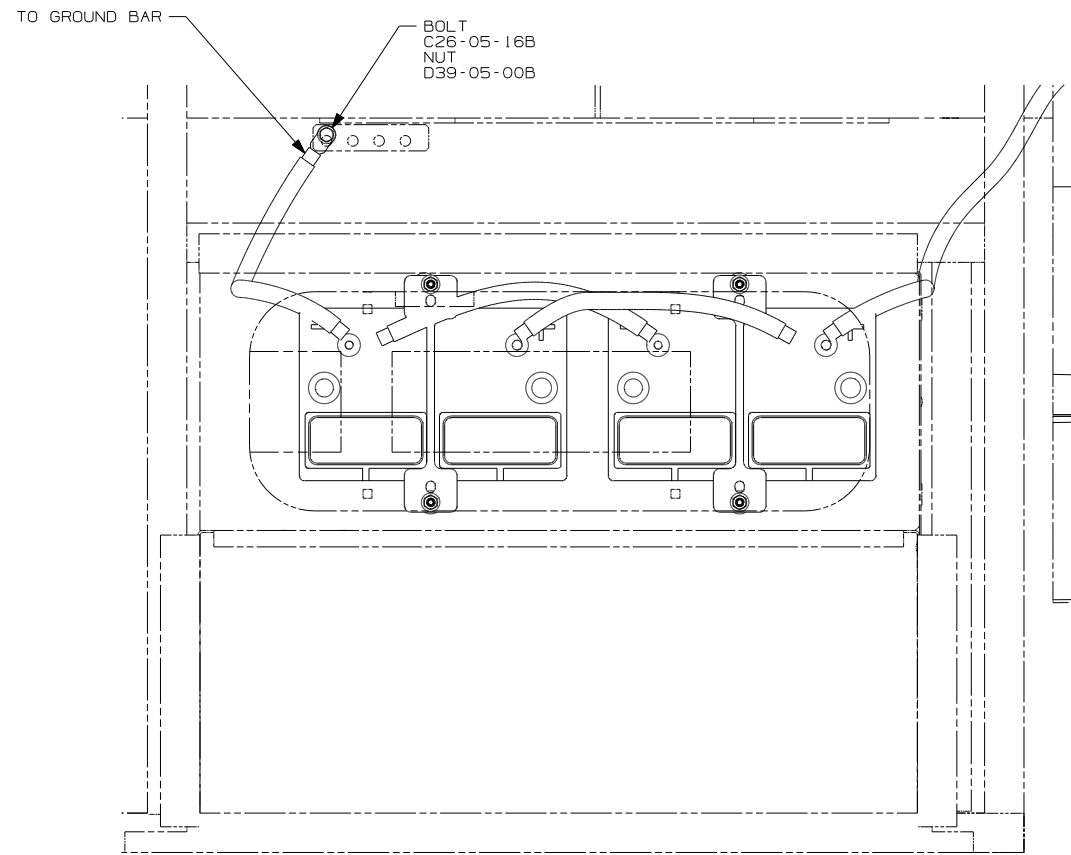

VIEW CA

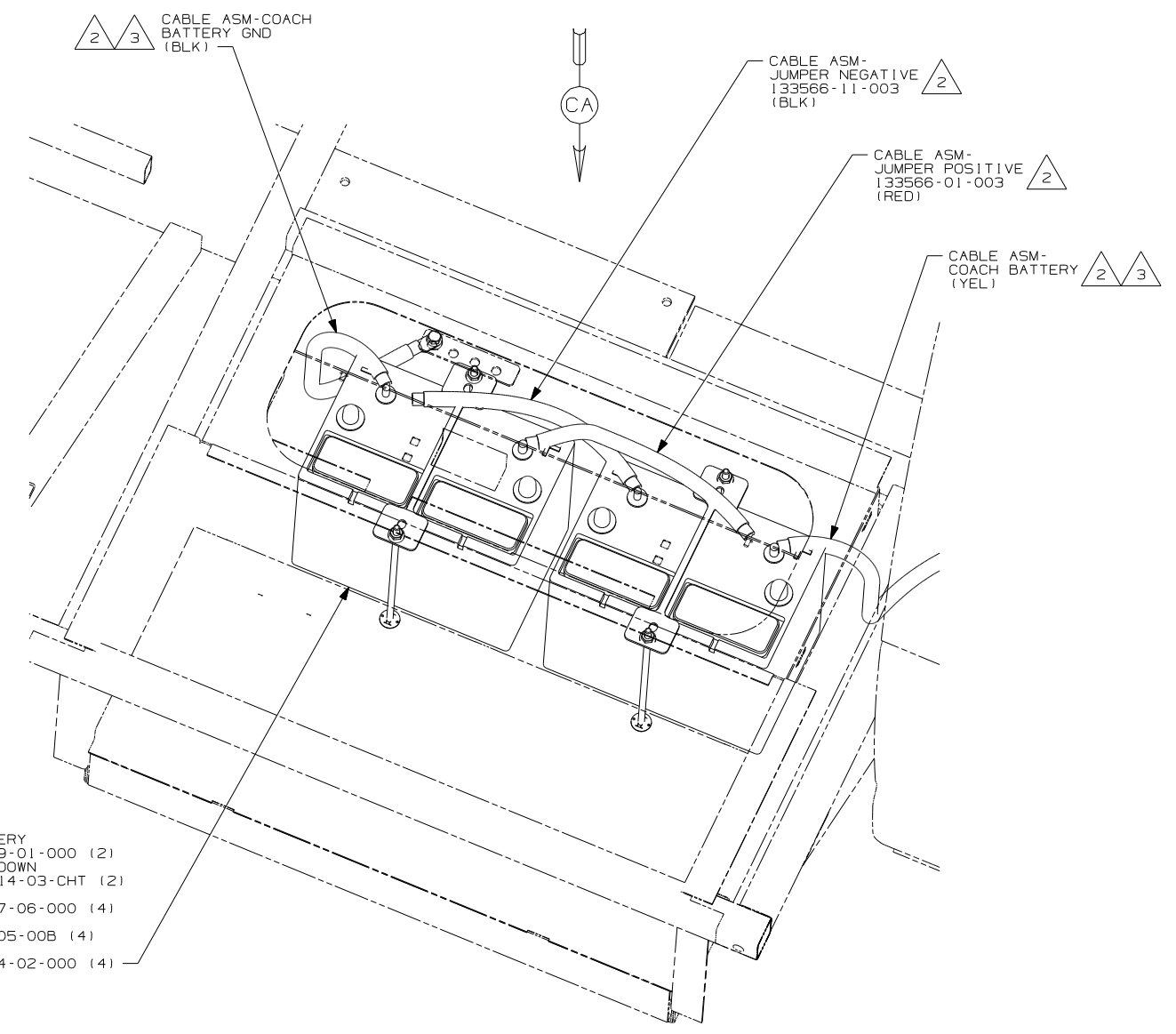

- BATTERY 63739-01-000 (2)
- TIE DOWN 160014-03-CHT (2)
- BOLT 51387-06-000 (4)
- NUT D39-05-00B (4)
- CLIP 44364-02-000 (4)

BATTERY BOX

- THE POSITIVE AND NEGATIVE BATTERY CABLES ARE TO BE TERMINATED ON OPPOSITE BATTERIES.
- BATTERY CABLES ARE NOT TO BE ROUTED OVER BATTERY FILL CAPS.

NOTES:
1. SEE WIRING INSTL-CHASSIS FOR ADDITIONAL INFORMATION.

- BATTERY - SECOND
- CODES/STANDARDS - CSA/CMVSS
- CODES/STANDARDS USA

-

FOR ELECTRICAL TORQUE SPECIFICATIONS SEE DWG NO. 128783-01-000

FOR ELECTRICAL CALLOUTS SEE DWG NO. 121339-01-000

FIRST USED	07 200/300 SER
TITLE	DO NOT SCALE DRAWING
TITLE	BATTERY INSTL
SHEET 3	PART NO 157362 REV

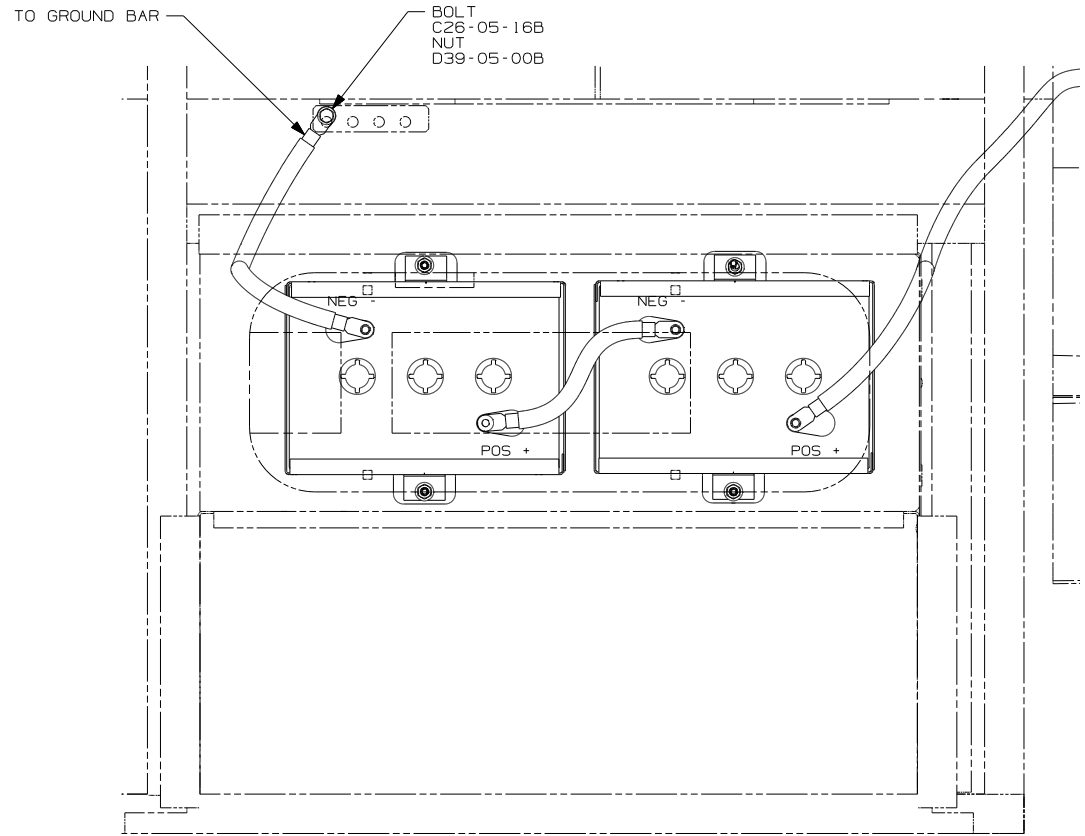

VIEW DA 

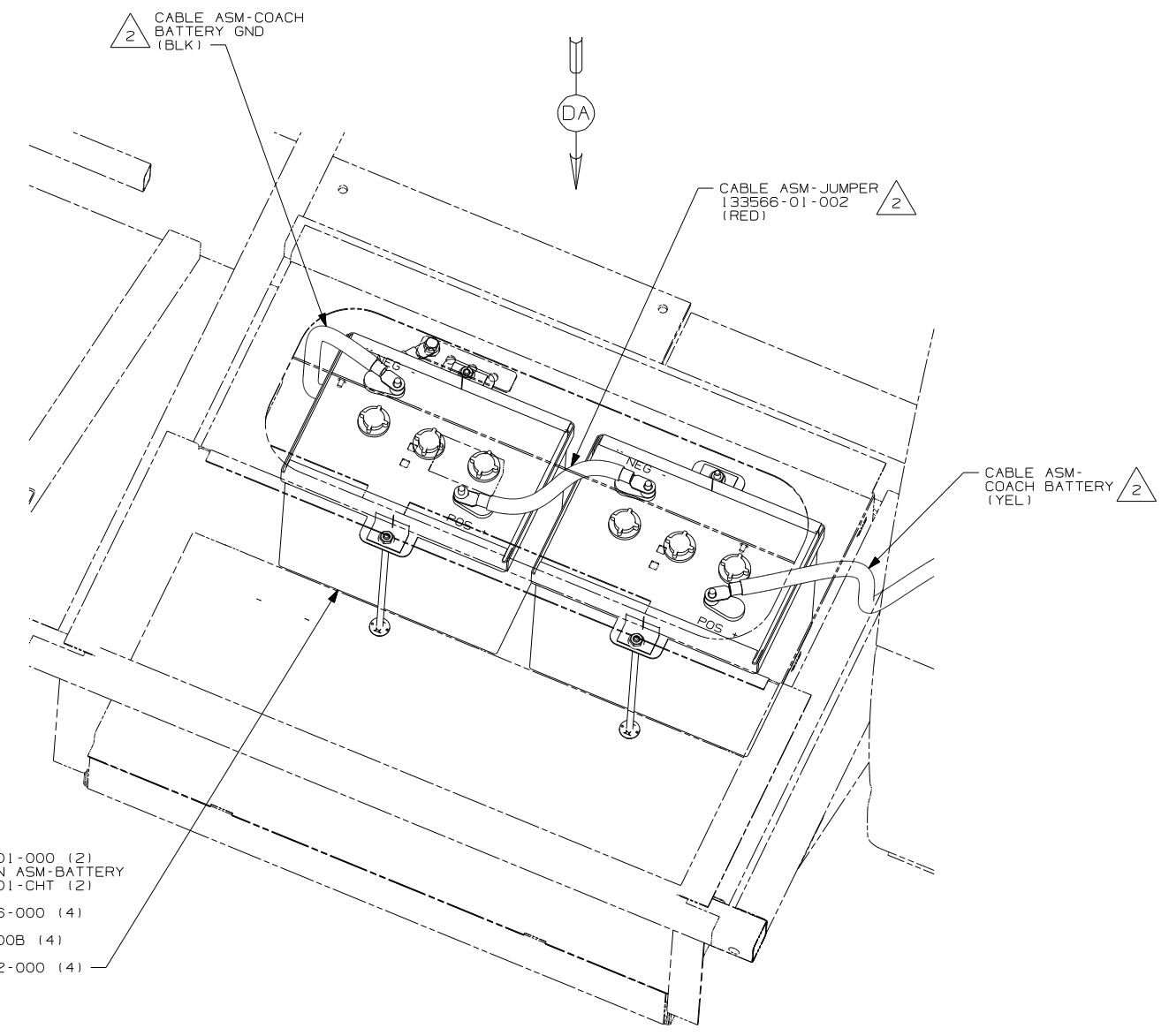



- BATTERY
- 146110-01-000 (2)
- TIE DOWN ASM-BATTERY
- 146624-01-CHT (2)
- BOLT
- 51387-06-000 (4)
- NUT
- D39-05-00B (4)
- CLIP
- 44364-02-000 (4)



BATTERY BOX

 BATTERY CABLES ARE NOT TO BE ROUTED OVER BATTERY FILL CAPS.

1. SEE WIRING INSTL-CHASSIS FOR ADDITIONAL INFORMATION.

NOTES:

-  GREAT ALASKAN RENTAL PACKAGE
-  CODES/STANDARDS-CSA/CMVSS
-  CODES/STANDARDS USA

FIRST USED	07 200/300 SER
TITLE:	DO NOT SCALE DRAWING
	BATTERY INSTL
SHEET 4	PART NO 157362 REV

FOR ELECTRICAL TORQUE SPECIFICATIONS SEE DWG NO. 128783-01-000

 FOR ELECTRICAL CALLOUTS SEE DWG NO. 121339-01-000