



DANGER

Danger of electrical shock, burns or death. Always remove all power sources before attempting any repair, service or diagnostic work. Power can be present from shore power, generator, inverter or battery. All power sources must be disabled and secured before performing any service.



CAUTION

If you lack the skills, tools or equipment to perform diagnostic or repair work leave such work to an authorized Winnebago Industries dealer or other qualified shop.

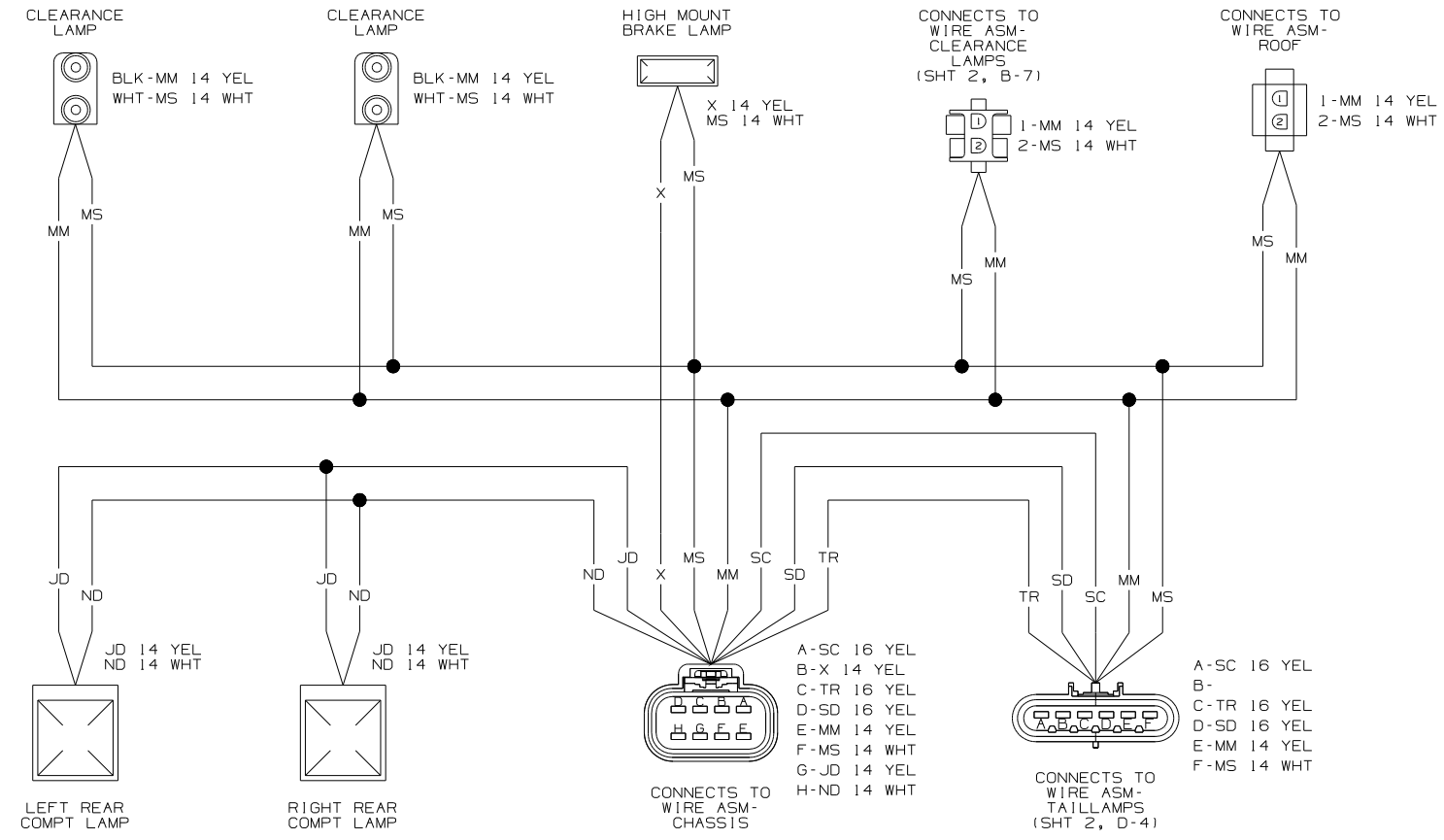

WIRING DIAGRAM-BACKWALL
(WIRE ASM 157261 REV-J)

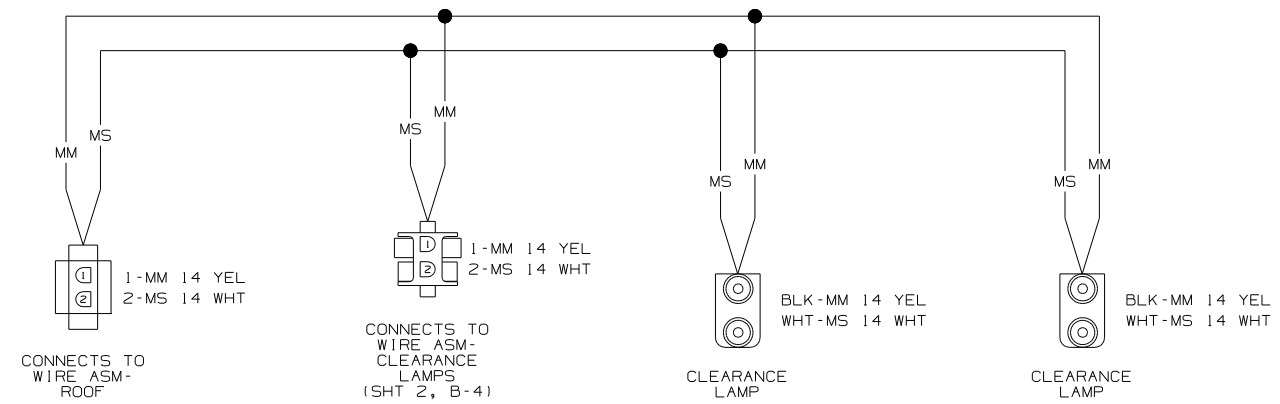

WIRING DIAGRAM-CLEARANCE LAMPS
(WIRE ASM 158067 REV-F)

- 5 SEE WIRING DIAGRAM-AUTO FOR ADDITIONAL INFORMATION.
- 4 SEE MANUFACTURERS DIAGRAM FOR ADDITIONAL INFORMATION.
- 3 GROUNDS ARE SHOWN AS A SINGLE LINE FOR EASE IN TRACING. EACH GROUND CIRCUIT IS SEPERATE IN THE HARNESS.
- 2 NOT A SPLICE POINT. INDICATES ENTRY INTO WIRING HARNESS.

1. SPLICES ARE THEORETICAL AND MAY DIFFER IN THE HARNESS.

NOTES:

WINNEBAGO		COPYRIGHT 2006 WINNEBAGO INDUSTRIES, INC.	
DFTR	ORIG. DATE		
CHKR	ALL DIMENSIONS ARE IN MILLIMETERS		
P.E.			
M.E.	FIRST USED		
DSNR	07 300-SERIES		
UNSPECIFIED TOLERANCES ARE:		MATERIAL:	
WHOLE DIM (X)	:		
ONE-PLACE (X.X)	:		
TWO-PLACE (X.XX)	:		
ANGLE	:		
THIRD ANGLE PROJECTION			
DO NOT SCALE DRAWING			
TITLE: WIRING DIAGRAM-AUTO LAMPS			
SHEET 1 OF 2	PART NO	156363	REV
REF:	1 12/4/2006		

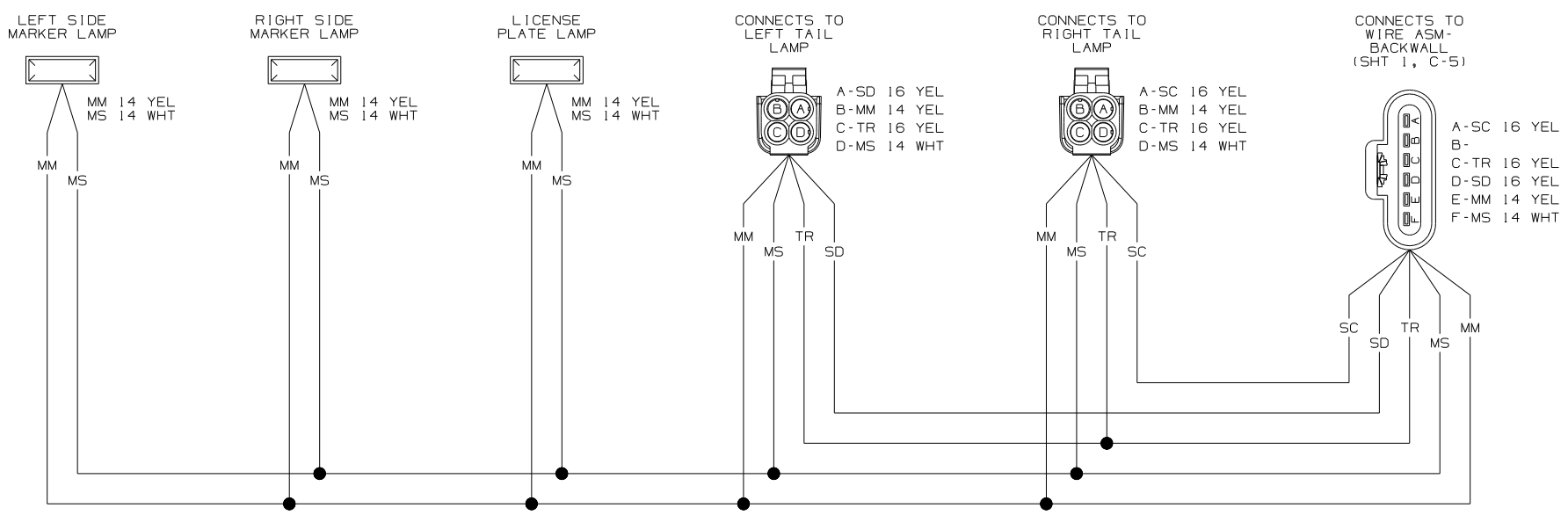

WIRING DIAGRAM-TAILLAMPS
(WIRE ASM 157476 REV-D)

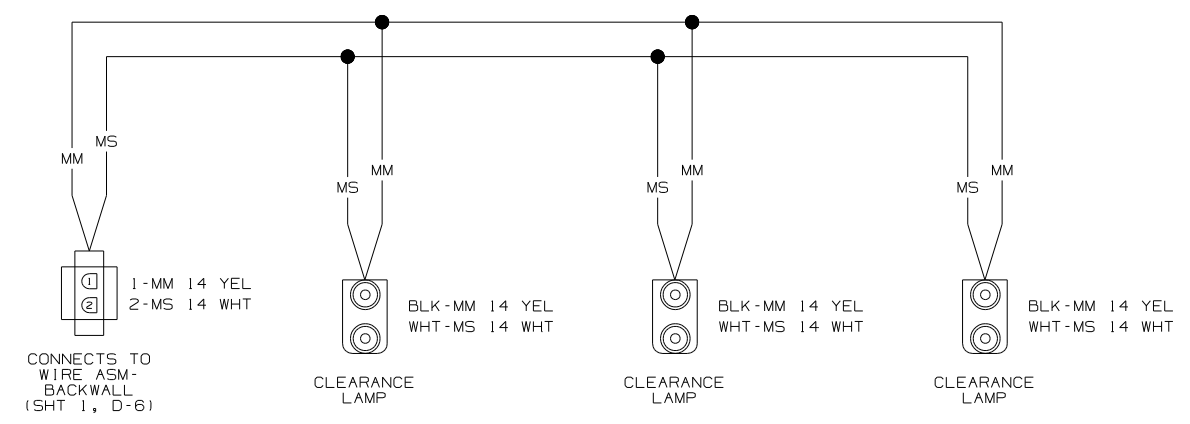

WIRING DIAGRAM-CLEARANCE LAMPS
(WIRE ASM 157475 REV-G)

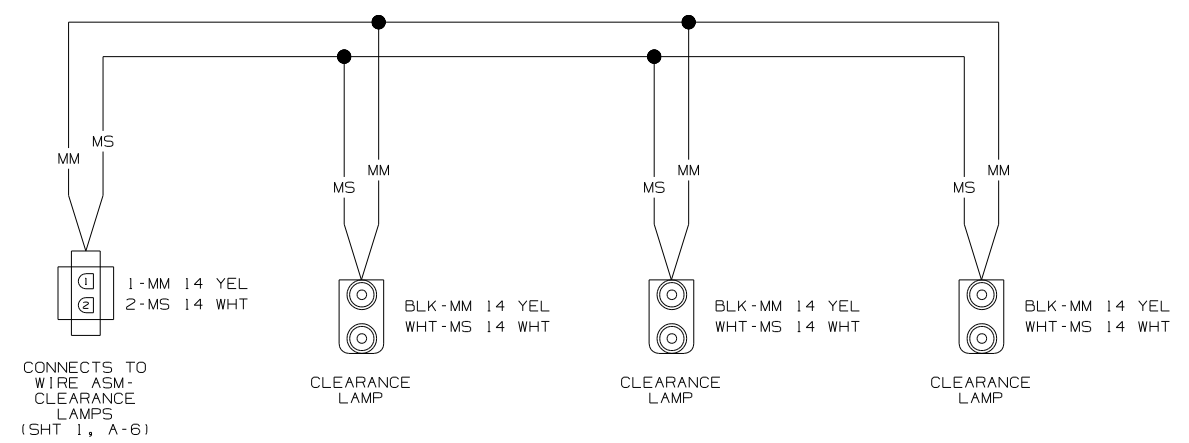

WIRING DIAGRAM-CLEARANCE LAMPS
(WIRE ASM 157475 REV-G)

- 5 SEE WIRING DIAGRAM-AUTO FOR ADDITIONAL INFORMATION.
 - 4 SEE MANUFACTURERS DIAGRAM FOR ADDITIONAL INFORMATION.
 - 3 GROUNDS ARE SHOWN AS A SINGLE LINE FOR EASE IN TRACING. EACH GROUND CIRCUIT IS SEPERATE IN THE HARNESS.
 - 2 NOT A SPLICE POINT. INDICATES ENTRY INTO WIRING HARNESS.
1. SPLICES ARE THEORETICAL AND MAY DIFFER IN THE HARNESS.

NOTES:

FIRST USED		07 300-SERIES	
DO NOT SCALE DRAWING			
TITLE: WIRING DIAGRAM-AUTO LAMPS			
SHEET 2	PART NO	156363	REV