

- (23T) DRAINAGE SYSTEM-HEATED
- (464) TOILET
- (265) CODES/STANDARDS-CSA/CMVSS
- (1B1) CODES/STANDARDS-USA

- 9 SEE WIRING INSTL-BODY, 12V FOR ELECTRICAL CONNECTION.
- 8 SECURE PIPES TO CABINET USING WIRE TIE 108046-02-000 AND SCREW G67-10-12B.
- 7 SECURE VENT TUBES TO FLOOR WITH CLAMP 62401-02-000 (2), SCREW G67-10-12B (2), AND BRACKET 136878-01-CHT (2).
- 6 VENT PIPE MUST PROJECT 51 MIN AND 64 MAX ABOVE ROOF FOR PROPER FIT AND FUNCTION.
- 5. SEAL AROUND SHOWER WITH SILICONE.
- 4. ALL EXTERIOR OPENINGS AROUND PIPE TO BE SEALED WITH 131264-03-000.
- 3. ALL PIPE AND FITTINGS TO BE ASSEMBLED WITH SOLVENT 4020-01-000 (USA), 4020-02-000 (CAN)
- 2. SLOPE OF TRAP ARM MUST BE 6 PER 305 mm.
- 1. SLOPE OF HORIZONTAL PIPING TO BE MIN 3 PER 305 mm.

NOTES:

(X-X)
FOR
DRAINAGE
CALLOUTS
SEE DWG NO
116229-01-000

WINNEBAGO		COPYRIGHT 2006 WINNEBAGO INDUSTRIES, INC.	
DFTR	ORIG. DATE		
CHKR	ALL DIMENSIONS ARE IN MILLIMETERS		
P.E.			
M.E.	FIRST USED		
DSNR	07 231C		
UNSPECIFIED TOLERANCES ARE:		MATERIAL:	
WHOLE DIM (X)	: 3		
ONE-PLACE (X.X)	: 1.5		
TWO-PLACE (X.XX)	: 0.50		
ANGLE	: 1°		
THIRD ANGLE PROJECTION			
DO NOT SCALE DRAWING			
TITLE: DRAINAGE SYSTEM INSTL			
SHEET 1 OF 3	PART NO	155409	REV
REF:	1 9/7/2006		

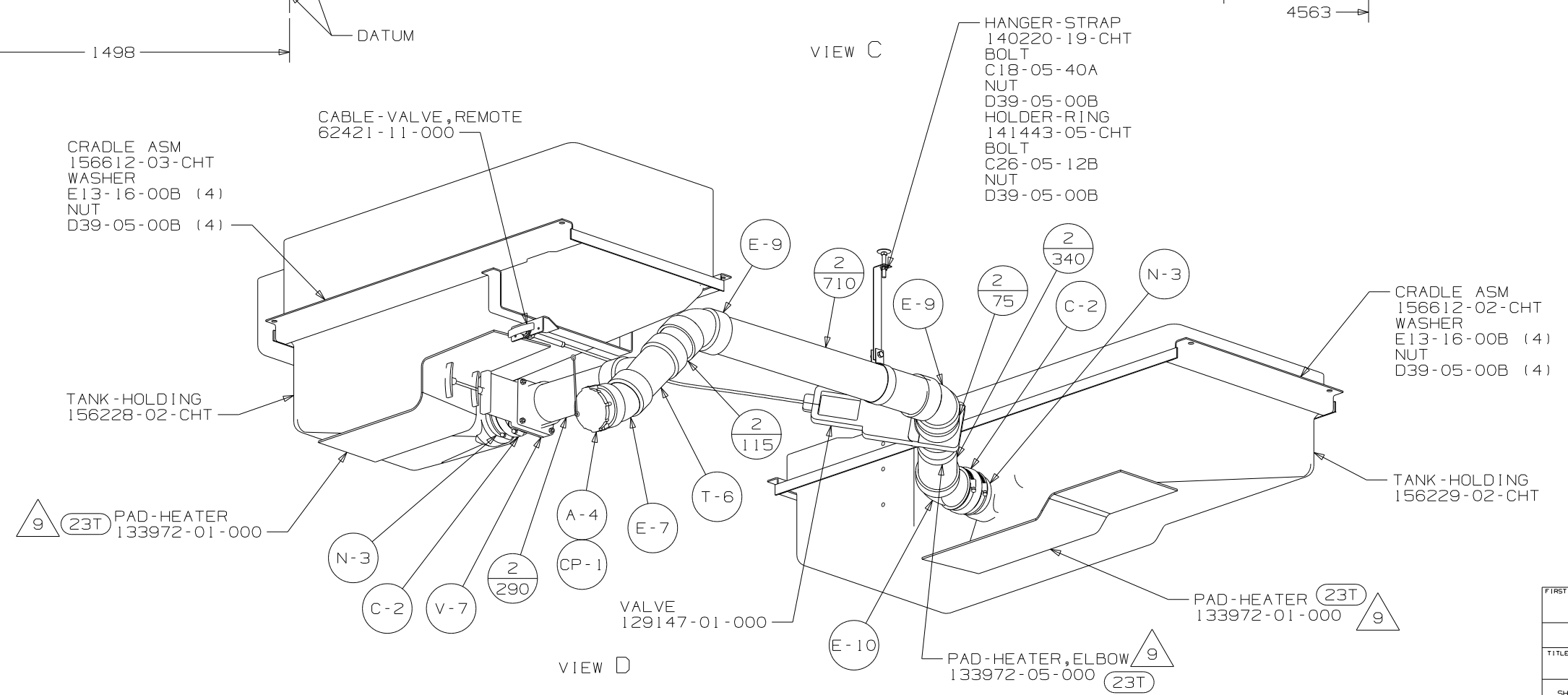
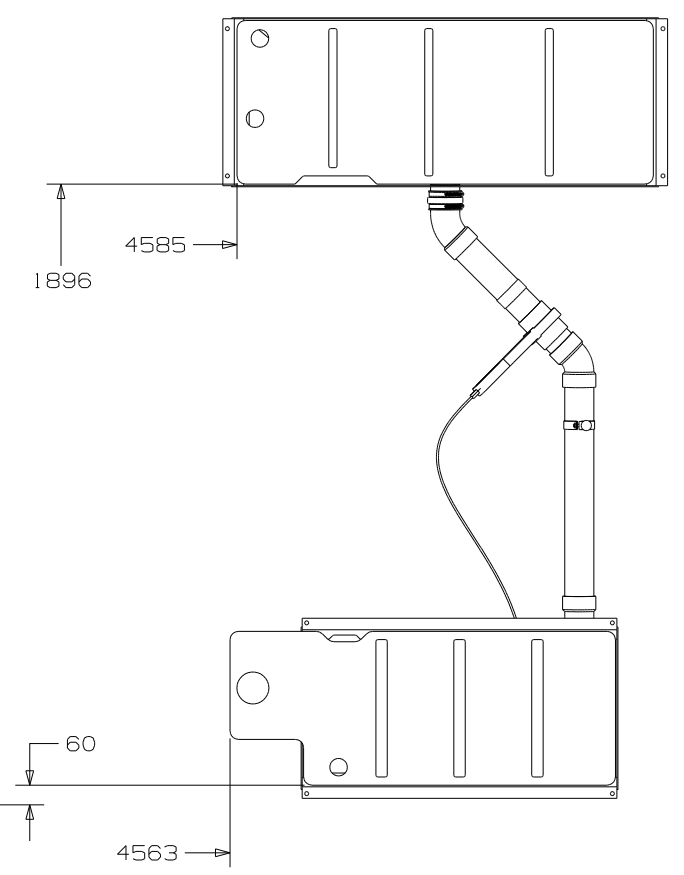
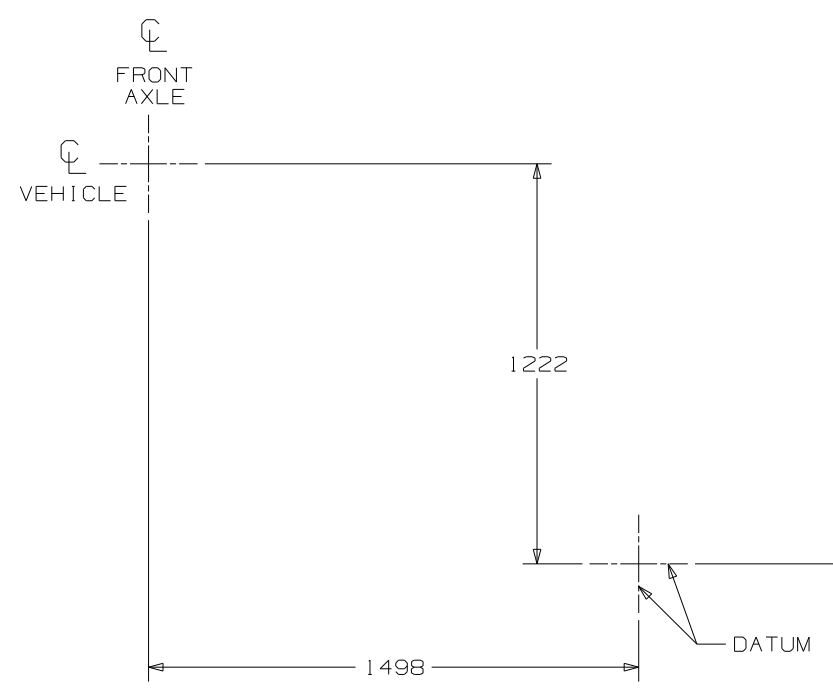

FIRST USED	07 231C
DO NOT SCALE DRAWING	
TITLE	DRAINAGE SYSTEM INSTL
SHEET 3	PART NO 155409 REV
1 9/7/2006	

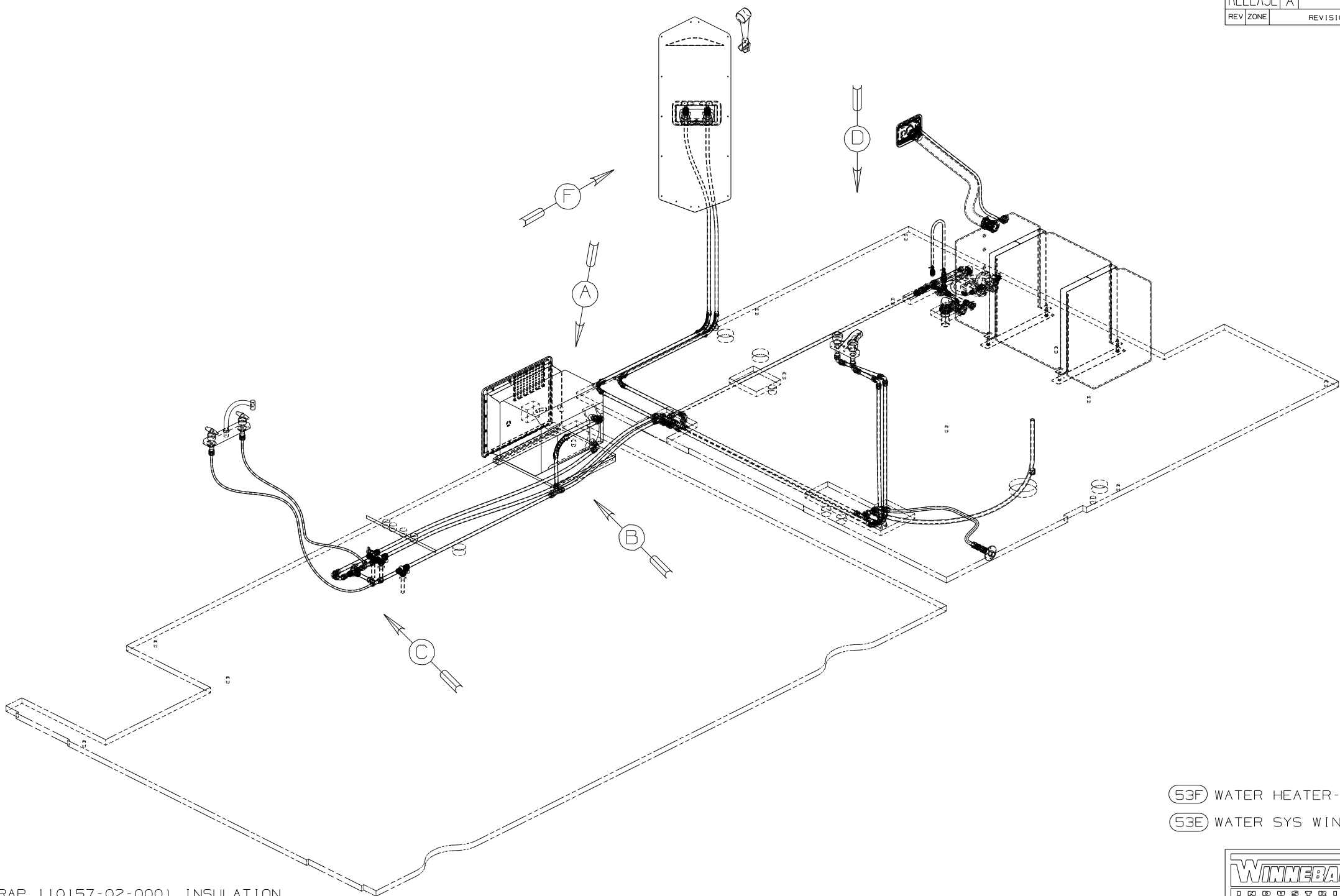

- (53F) WATER HEATER-ELEC. IGNITION
- (53E) WATER SYS WINTERIZATION PKG

- 7 ADD PIPE WRAP (LADDER SCRAP 110157-02-000) INSULATION.
 - 6 ADD TEFLON TAPE 10405-03-000.
 - 5 ADD TEFLON TAPE 10405-02-000.
 - 4 ADD TEFLON TAPE 10405-01-000.
3. ALL TUBING TO BE SECURED AT 1200 INTERVALS MAXIMUM WITH CLAMP 10495-01-000 AND SCREW G67-10-12B OR EQUIVALENT.
 2. TUBING TO BE INSTALLED WITH SUFFICIENT SLOPE TO PROVIDE DRAINAGE TO NEAREST VALVE.
 1. PLASTIC FITTINGS TO BE SEALED WITH SEALANT 84456-01-000.

NOTES:

WINNEBAGO		COPYRIGHT 2006 WINNEBAGO INDUSTRIES, INC.	
DFT	ORIG. DATE	ALL DIMENSIONS ARE IN MILLIMETERS	
CHKR		FIRST USED	
P.E.		07 231C	
M.E.		UNSPECIFIED TOLERANCES ARE:	
DSNR		MATERIAL:	
		WHOLE DIM (X)	: 3
		ONE-PLACE (X.X)	: 1.5
		TWO-PLACE (X.XX)	: 0.50
		ANGLE	: 1°
THIRD ANGLE PROJECTION			
DO NOT SCALE DRAWING			
TITLE: WATER SYSTEM INSTL			
SHEET 1 OF 3	PART NO	155412	REV
REF	1 11/9/2006		

(X-X)
FOR
WATER
CALLOUTS
SEE DWG NO
116230-01-000

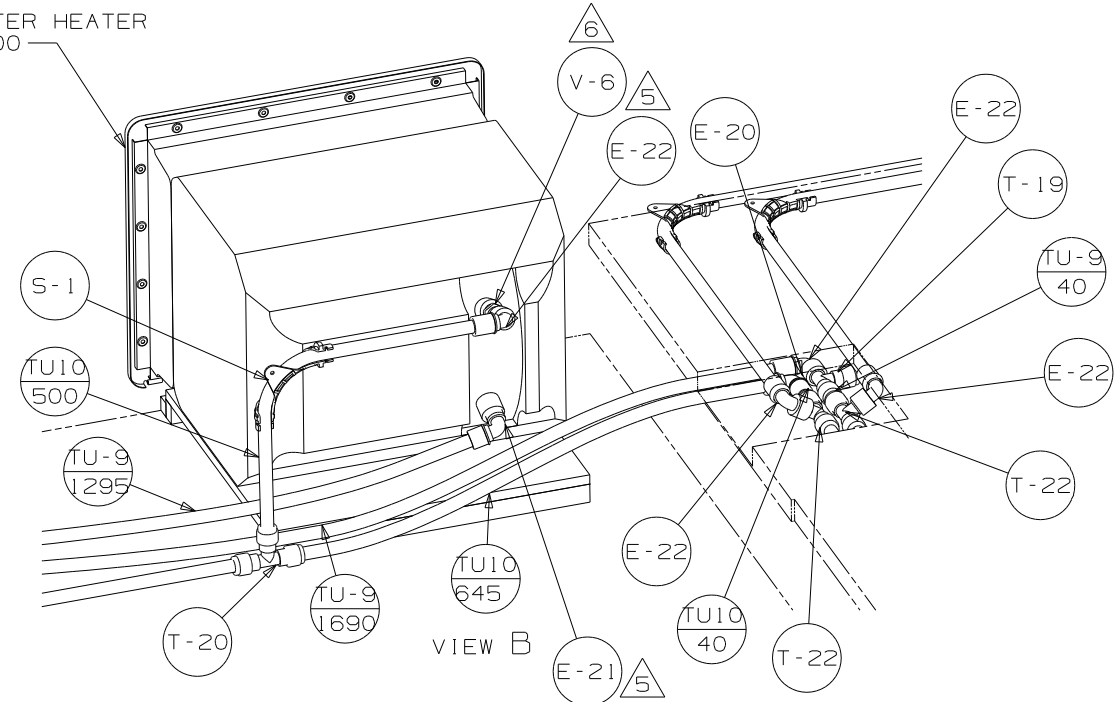
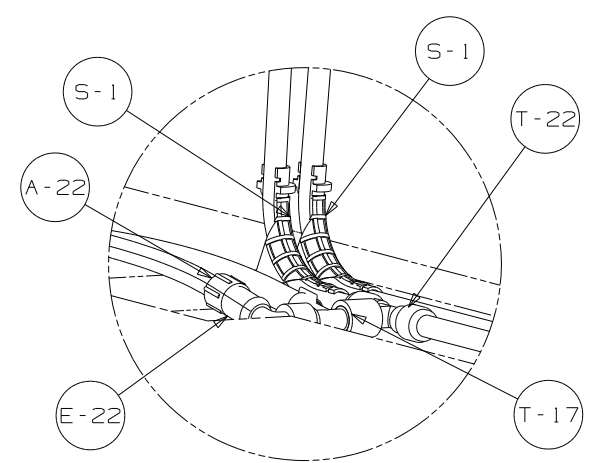
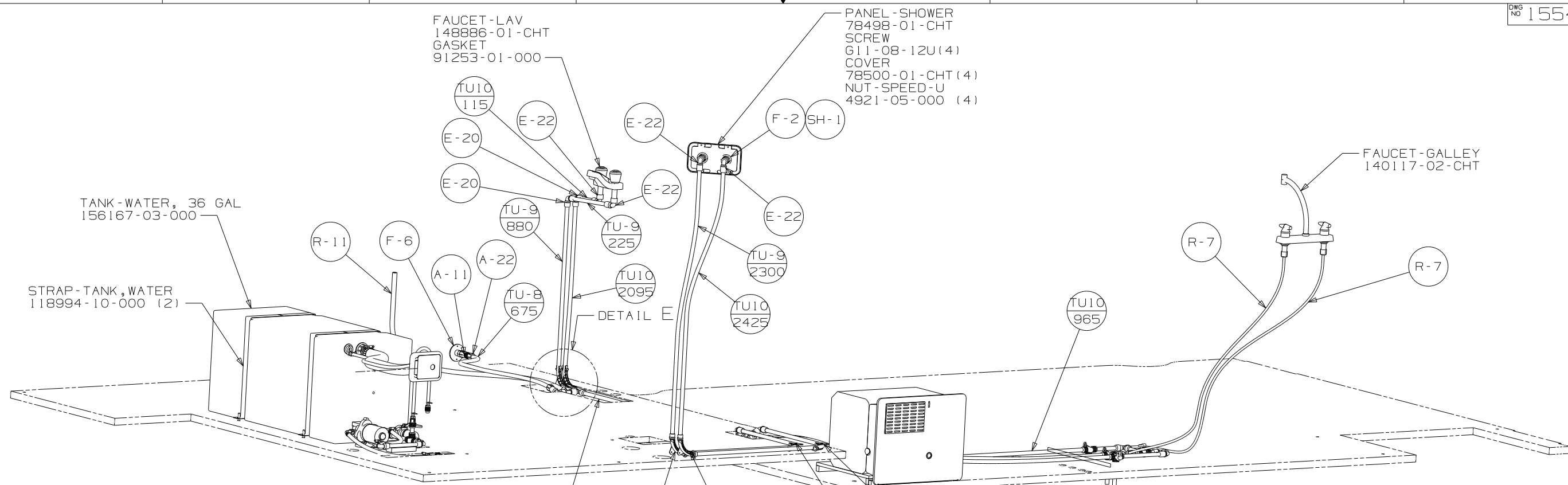

FIRST USED	07 231C
DO NOT SCALE DRAWING	
TITLE	WATER SYSTEM INSTL
SHEET 2	PART NO 155412 REV

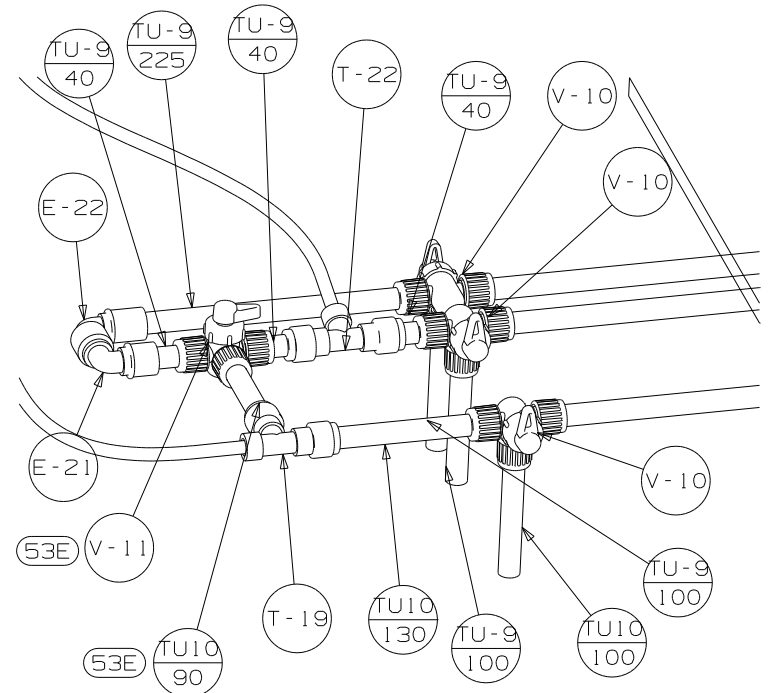

VIEW C
(SHOWN WITHOUT FLOOR)

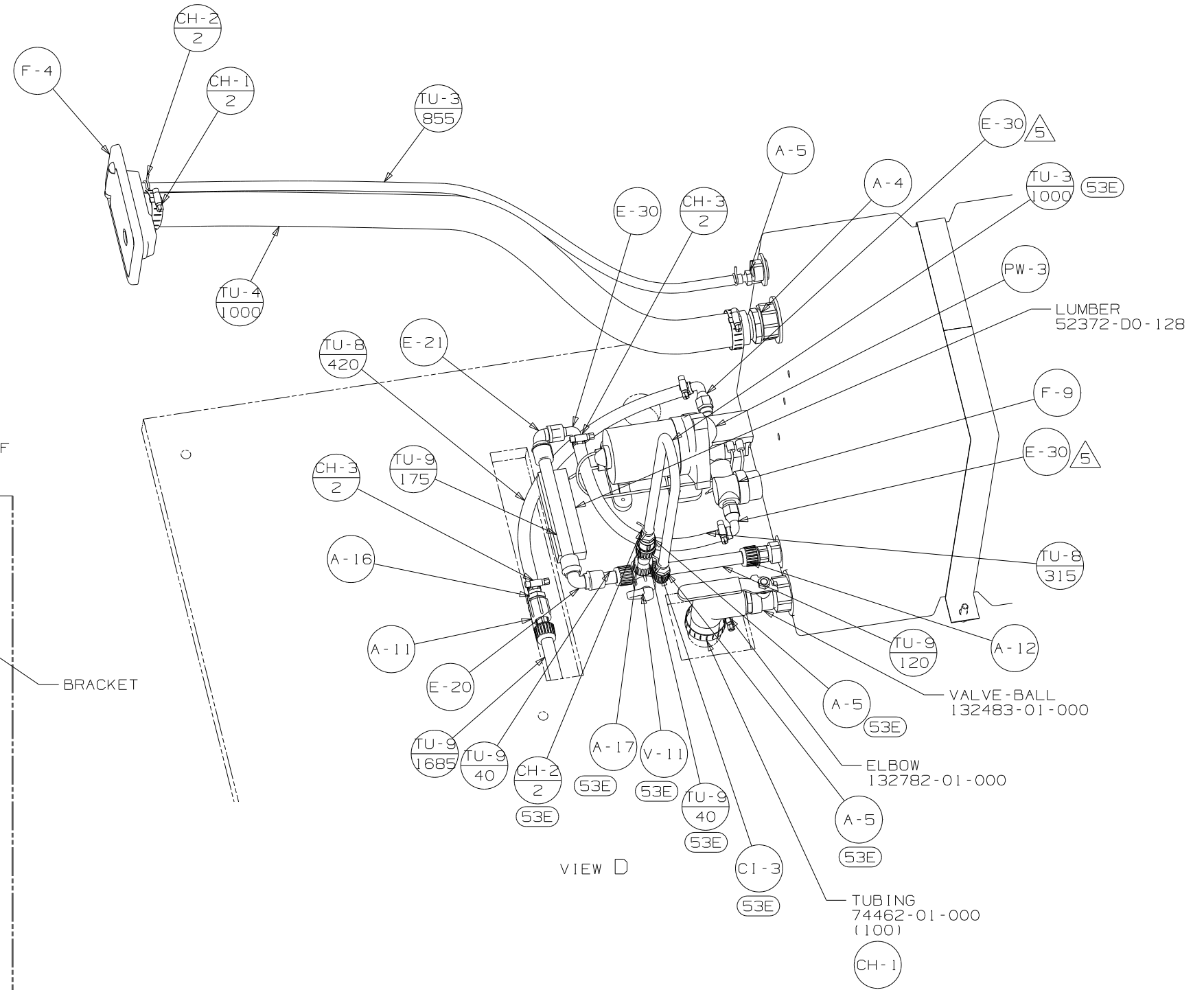

VIEW D

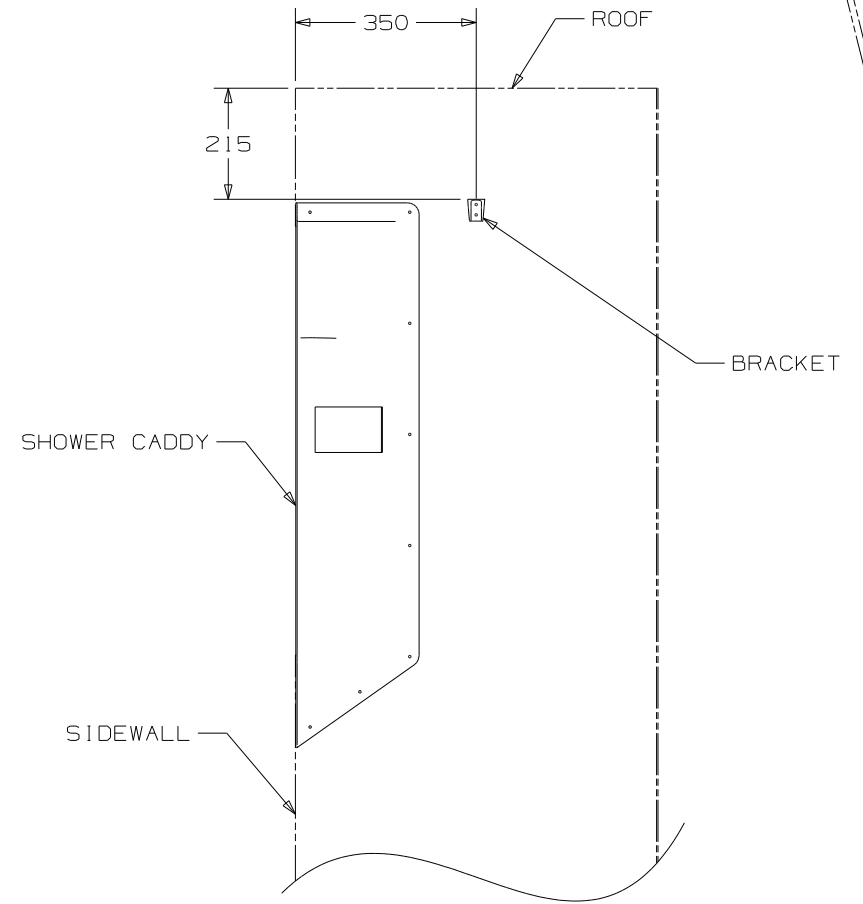

VIEW F

FIRST USED	07 231C	
TITLE	DO NOT SCALE DRAWING	
TITLE	WATER SYSTEM INSTL	
SHEET 3	PART NO	155412 REV