

- (23T) DRAINAGE SYSTEM-HEATED
- (464) TOILET
- (265) CODES/STANDARDS-CSA/CMVSS
- (1B1) CODES/STANDARDS-USA

- 9 SEE WIRING INSTL-BODY, 12V FOR ELECTRICAL CONNECTION.
- 8. SECURE PIPES TO CABINET USING WIRE TIE 108046-02-000 AND SCREW G67-10-12B.
- 7 SECURE VENT TUBES TO FLOOR WITH CLAMP 62401-02-000 (2), SCREW G67-10-12B (2), AND BRACKET 136878-01-CHT (2).
- 6 VENT PIPE MUST PROJECT 51 MIN AND 64 MAX ABOVE ROOF FOR PROPER FIT AND FUNCTION.
- 5. SEAL AROUND SHOWER WITH SILICONE.
- 4. ALL EXTERIOR OPENINGS AROUND PIPE TO BE SEALED WITH 131264-03-000.
- 3. ALL PIPE AND FITTINGS TO BE ASSEMBLED WITH SOLVENT 4020-01-000 (USA), 4020-02-000 (CAN).
- 2. SLOPE OF TRAP ARM MUST BE 6 PER 305 mm.
- 1. SLOPE OF HORIZONTAL PIPING TO BE MIN 3 PER 305 mm.

NOTES:

FOR
DRAINAGE
CALLOUTS
SEE DWG NO
116229-01-000

WINNEBAGO		COPYRIGHT 2006 WINNEBAGO INDUSTRIES, INC.	
DFT	ORIG. DATE	ALL DIMENSIONS ARE IN MILLIMETERS	
CHKR		FIRST USED	
P.E.		07 228P	
M.E.		UNSPECIFIED TOLERANCES ARE:	
DSNR		MATERIAL:	
		WHOLE DIM (X)	: 3
		ONE-PLACE (X.X)	: 1.5
		TWO-PLACE (X.XX)	: 0.50
		ANGLE	: 1°
THIRD ANGLE PROJECTION		DO NOT SCALE DRAWING	
TITLE: DRAINAGE SYSTEM INSTL			
SHEET 1 OF 3	PART NO	158441	REV
REF:	1 9/27/2006		

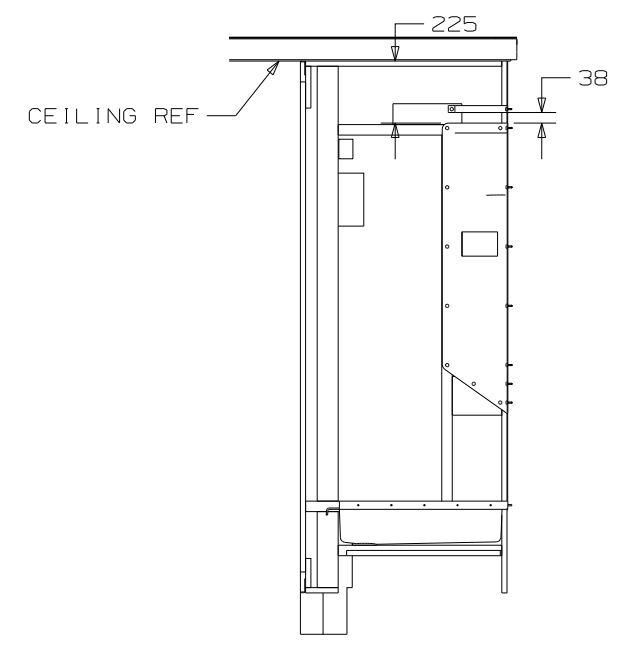

- SHOWER PAN
127586-02-CHT
- SCREW
G11-08-12U (10)
- G39-08-12U (6)
- COVER
78500-01-CHT (16)
- CADDY
105707-01-CHT
- SCREW
G11-08-12U (8)
- G39-08-12U (8)
- COVER
78500-01-CHT (16)
- RETAINER-SHELF, SHOWER
113714-02-CHT
- SCREW
G11-08-12U
- G39-08-12U
- COVER
78500-01-CHT (2)
- STRAINER
66440-01-000
- SEALER
69640-01-000
- NUT
130403-01-000
- WASHER-RUBBER
127440-02-CHT
- TAILPIECE
11069-06-000

- 464 TOILET
147421-05-CHT
- SCREW
87721-01-000 (6)

- SINK
148870-01-CHT
- STRAINER
92303-01-000 (2)
- BRACKET
140002-01-CHT (8)
- SCREW
G67-10-08B (8)
- SEAL
(A/R)

- SINK
96927-01-CHT
- SEAL
91255-02-000 (A/R)

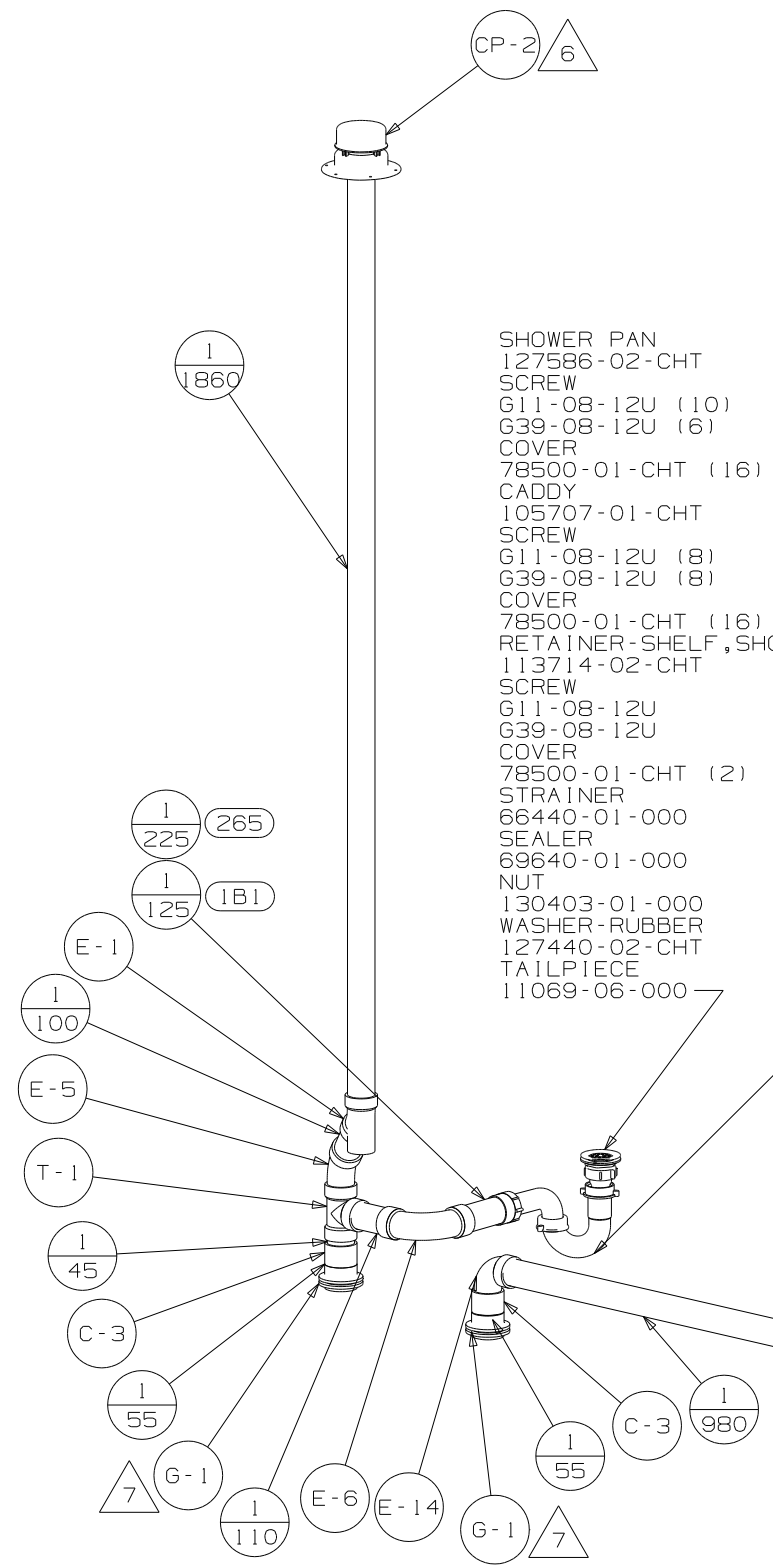

- A-15 (1B1)
- P-3 (265)
- P-1 (1B1)

VIEW A

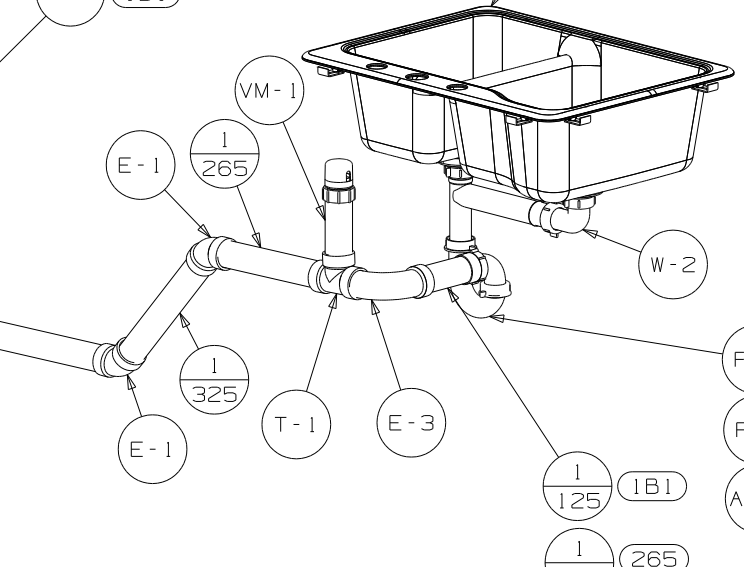

- P-1 (1B1)
- P-3 (265)
- A-15 (1B1)
- 1/125 (1B1)
- 1/225 (265)

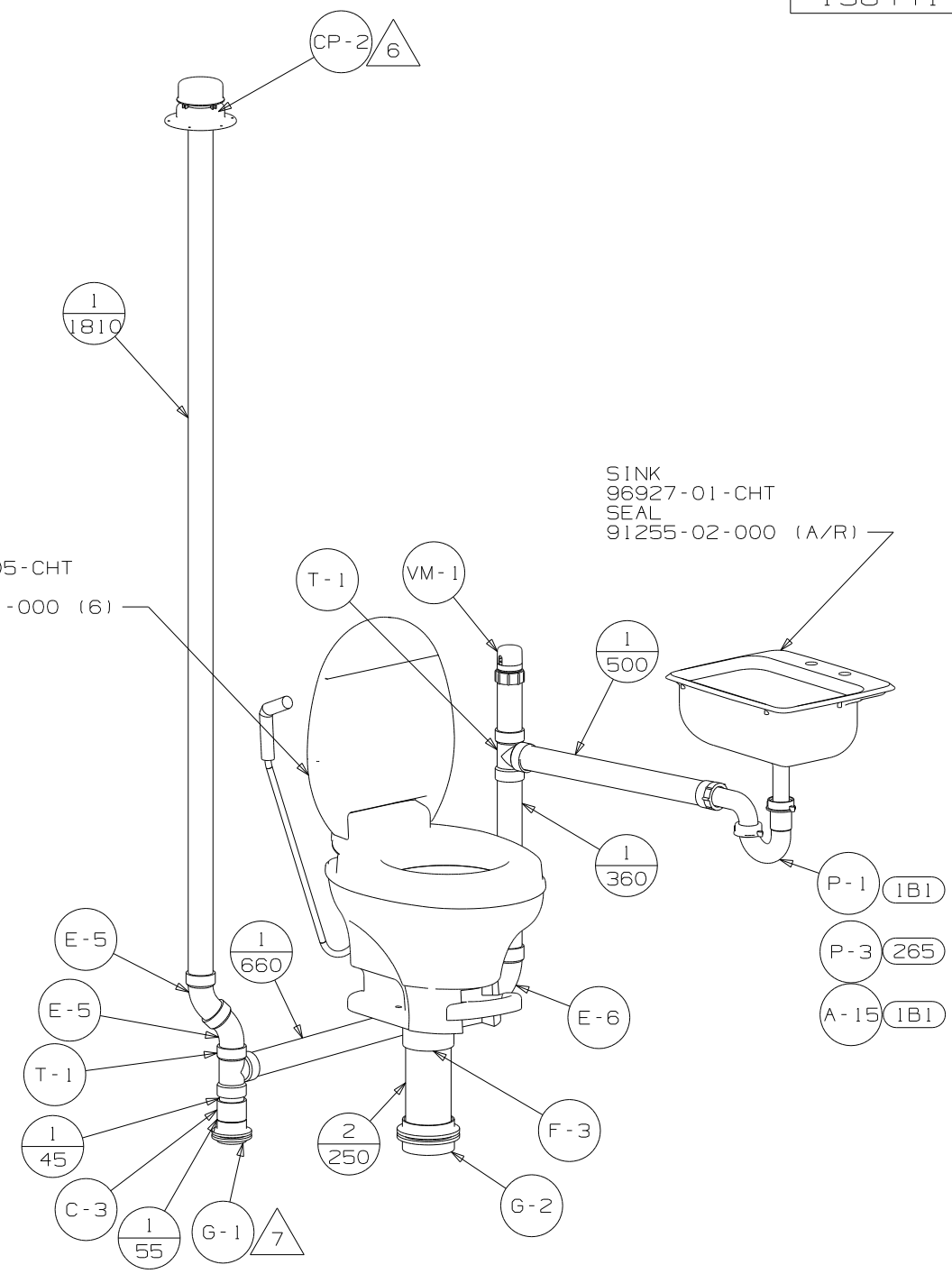

VIEW B

FIRST USED	07 228P		
TITLE	DO NOT SCALE DRAWING		
	DRAINAGE SYSTEM INSTL		
SHEET 2	PART NO	158441	REV

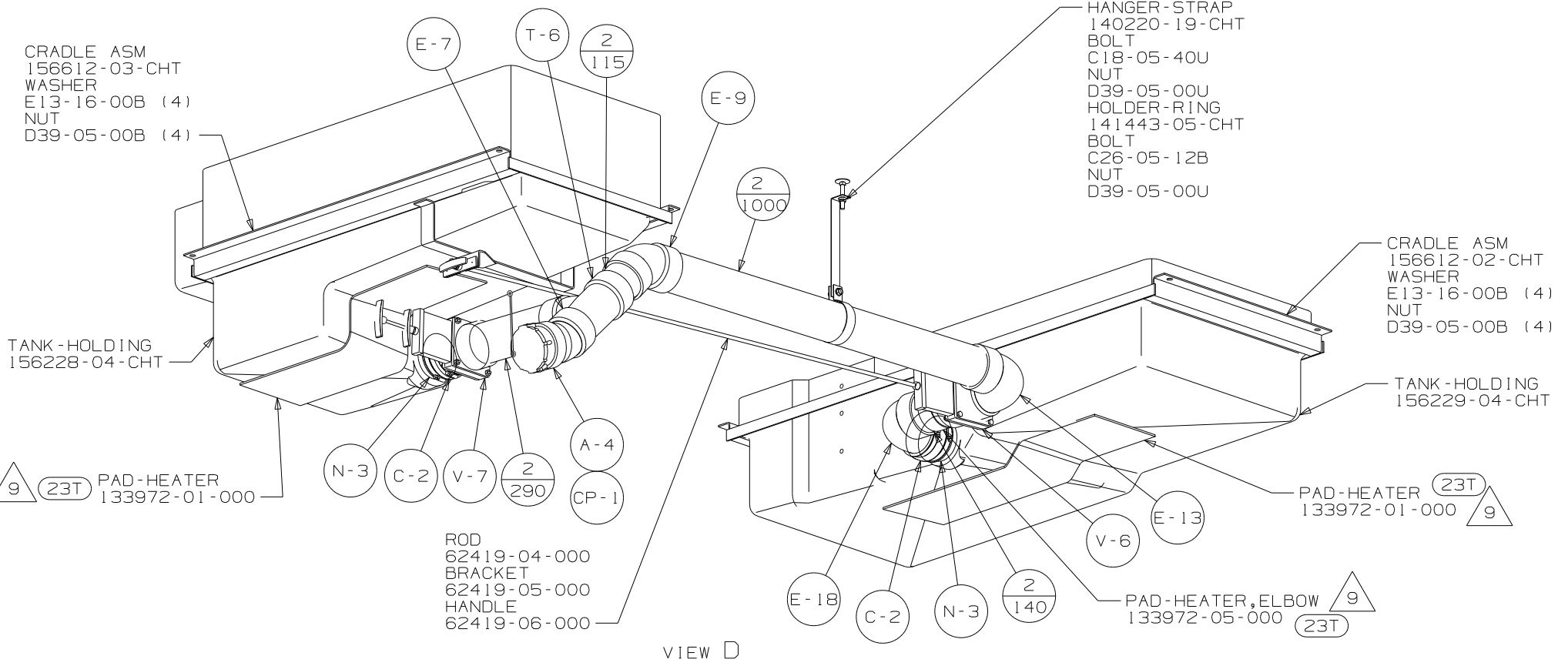
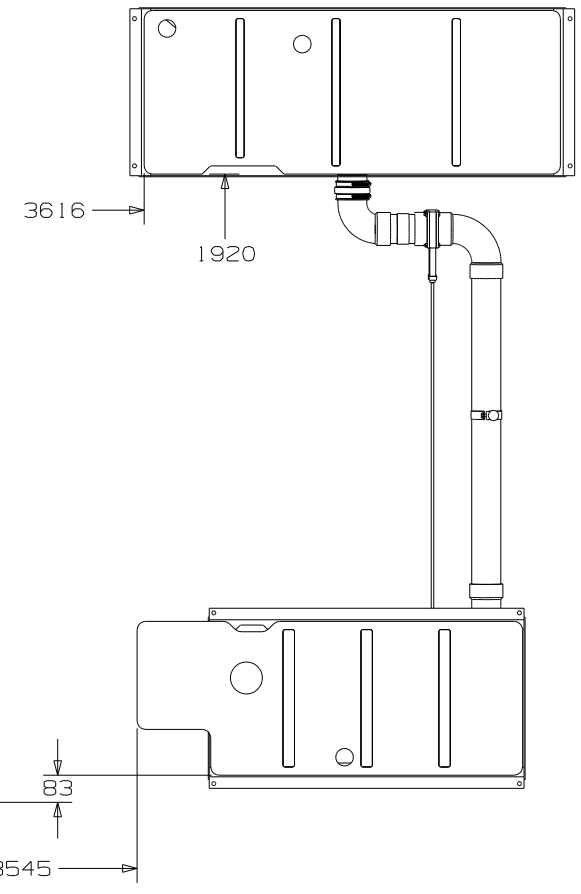
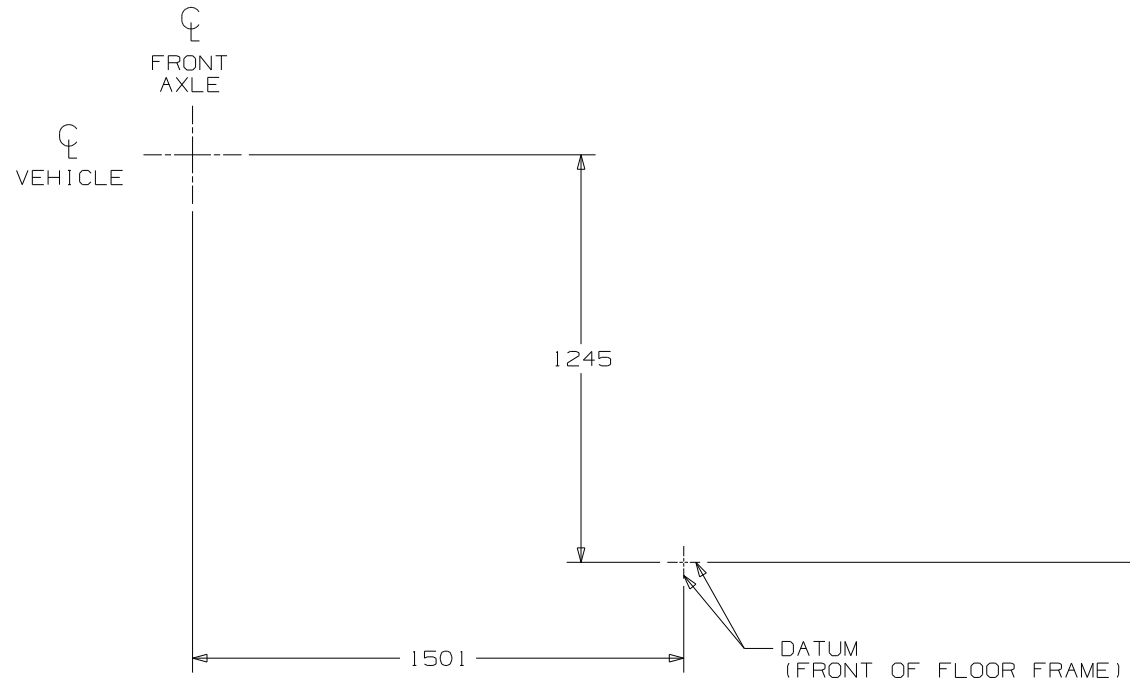

FIRST USED	07 228P	
DO NOT SCALE DRAWING		
TITLE	DRAINAGE SYSTEM INSTL	
SHEET 3	PART NO 158441	REV

8 7 6 5 4 3 2

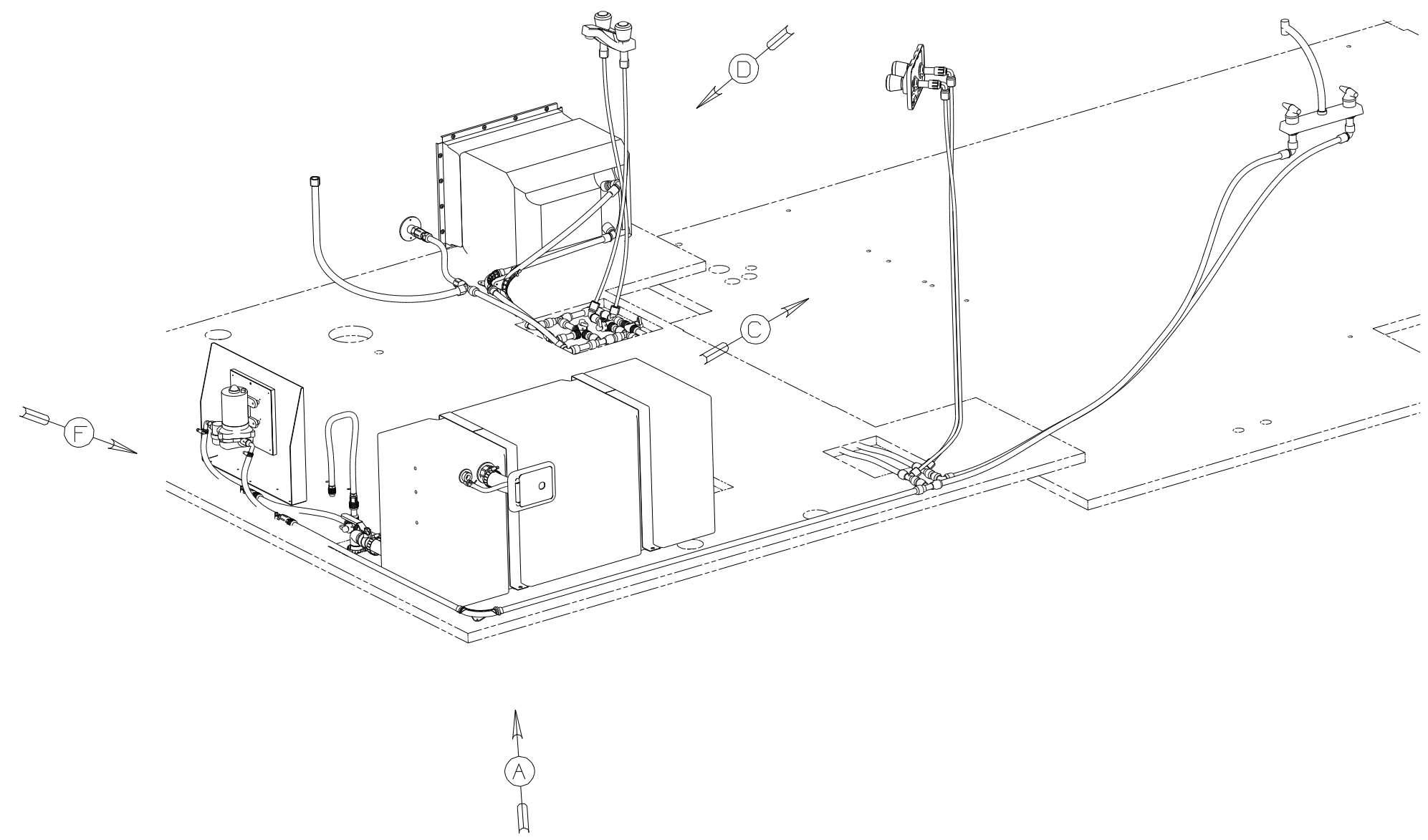

- NOTES:
3. ALL TUBING TO BE SECURED AT 1200 INTERVALS MAXIMUM WITH CLAMP 10495-01-000 AND SCREW G67-10-12B OR EQUIVALENT.
 2. TUBING TO BE INSTALLED WITH SUFFICIENT SLOPE TO PROVIDE DRAINAGE TO NEAREST VALVE.
 1. PLASTIC FITTINGS TO BE SEALED WITH SEALANT 84456-01-000.

(X-X)
FOR
WATER
CALLOUTS
SEE DWG NO
116230-01-000

WINNEBAGO		COPYRIGHT 2006 WINNEBAGO INDUSTRIES, INC.	
DFTR	ORIG. DATE	ALL DIMENSIONS ARE IN MILLIMETERS	
CHKR		FIRST USED	
P.E.		07 228P	
M.E.		UNSPECIFIED TOLERANCES ARE:	
DSNR		MATERIAL:	
		WHOLE DIM (X)	: 3
		ONE-PLACE (X.X)	: 1.5
		TWO-PLACE (X.XX)	: 0.50
		ANGLE	: 1°
THIRD ANGLE PROJECTION		DO NOT SCALE DRAWING	
TITLE: WATER SYSTEM INSTL			
SHEET 1 OF 3	PART NO	158440	REV
REF:	1 11/7/2006		

8 7 6 5 4 3 2

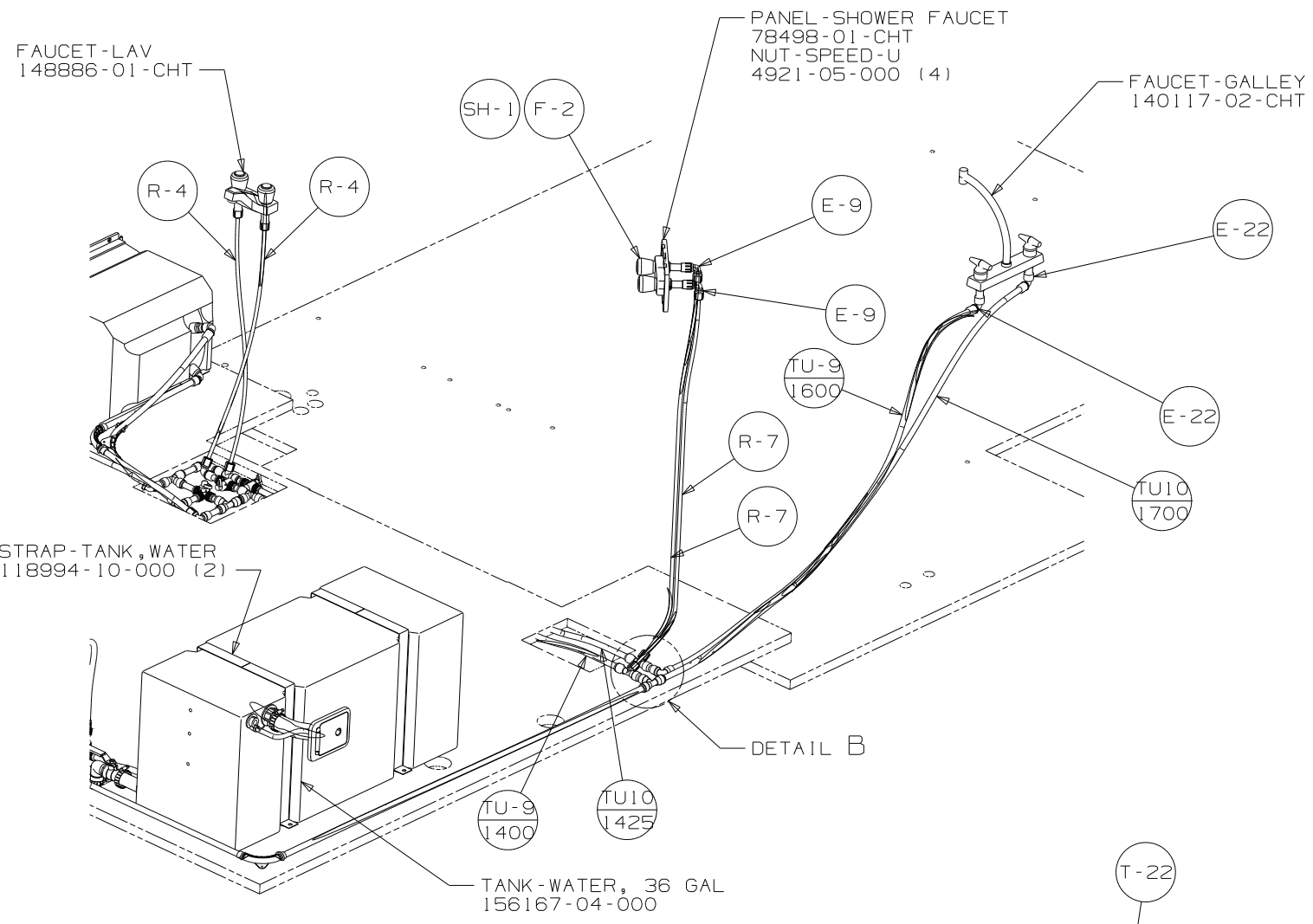

VIEW A

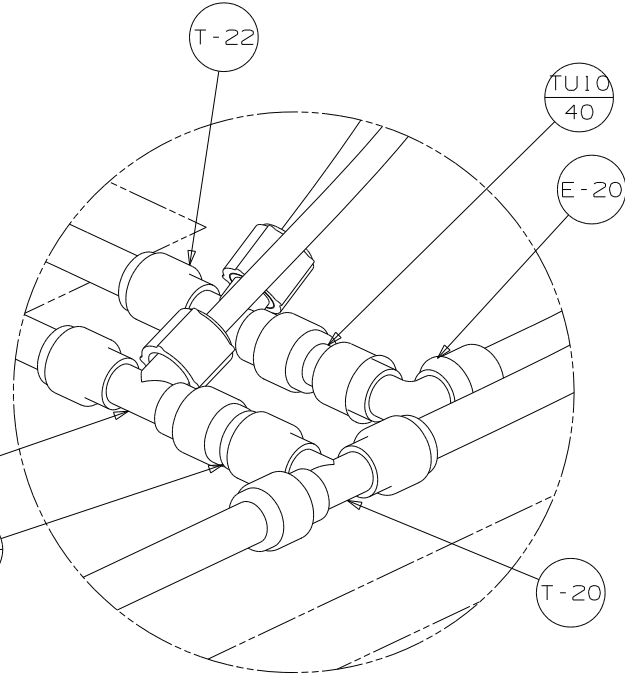

DETAIL B

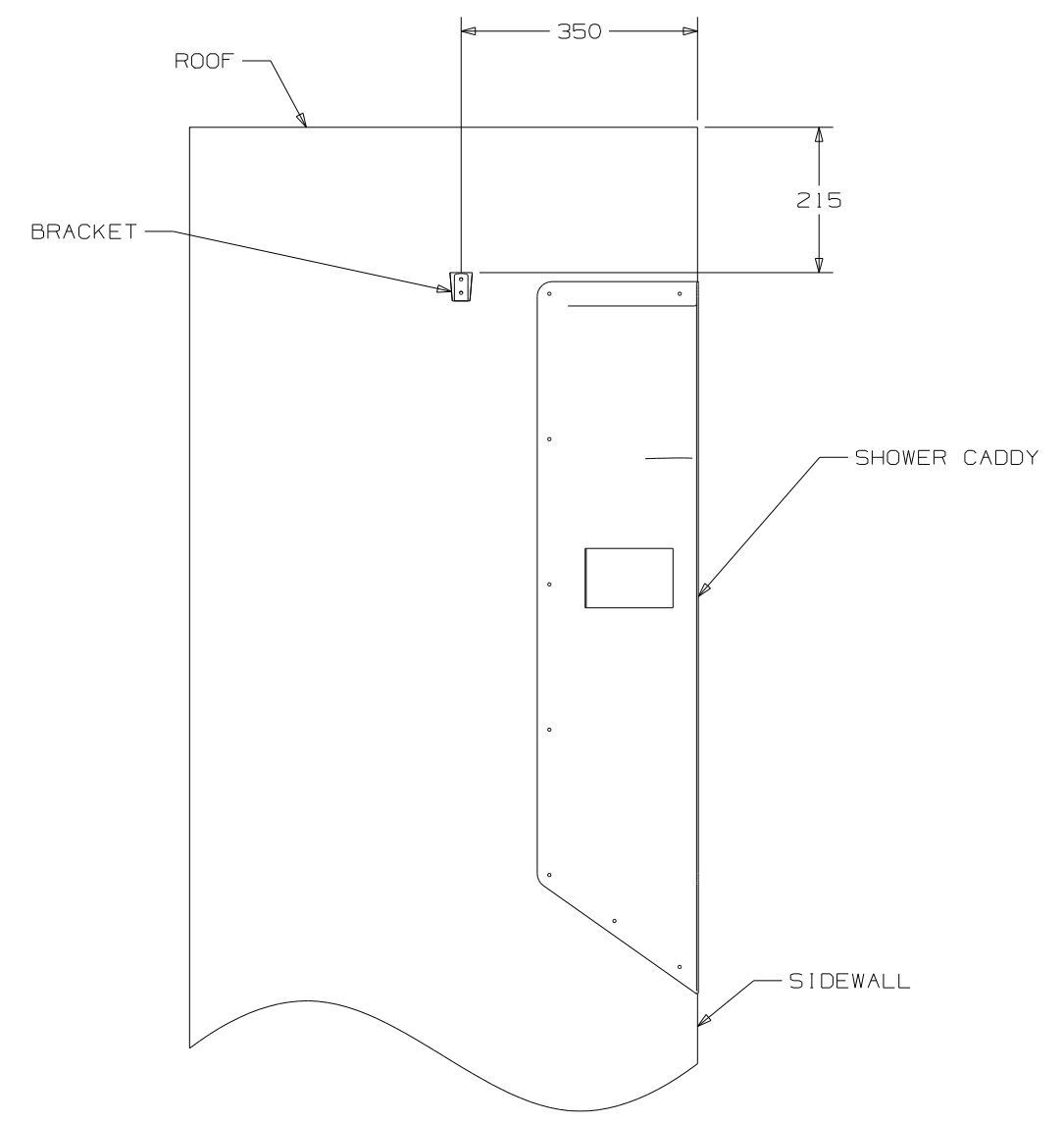

VIEW C

FIRST USED	07 228P		
TITLE	DO NOT SCALE DRAWING		
	WATER SYSTEM INSTL		
SHEET 2	PART NO	158440	REV

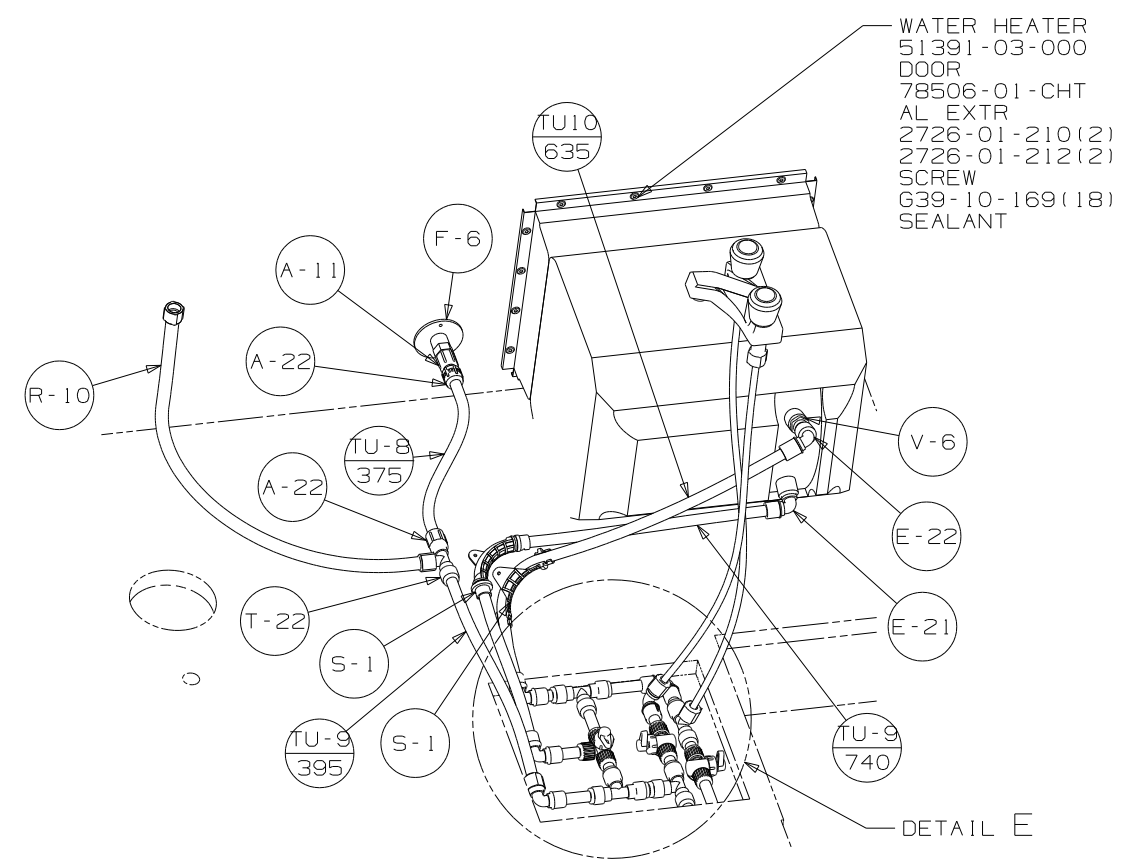

VIEW D

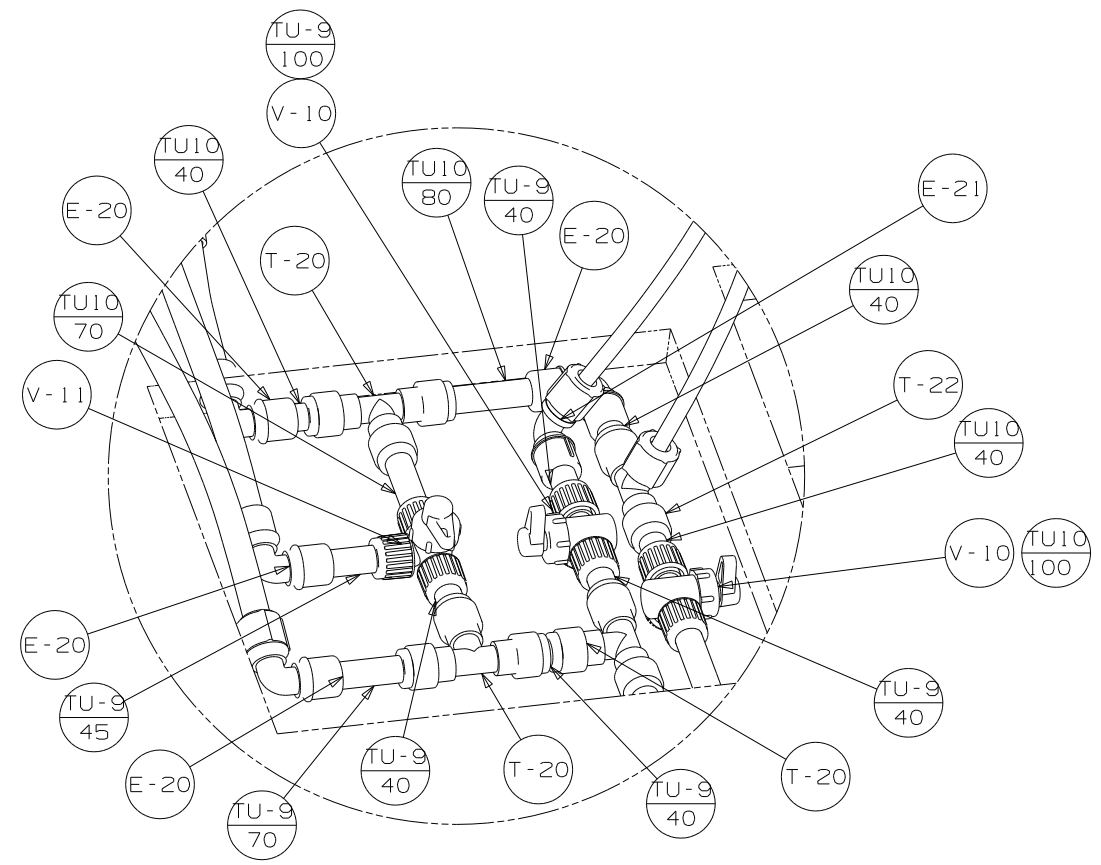

DETAIL E

PANEL-WATER PUMP
149477-02-CHT
SCREW
639-10-16T (4)

FOAM-PAD
140364-01-CHT

BRACKET-MOUNTING, WATER PUMP
156298-02-CHT

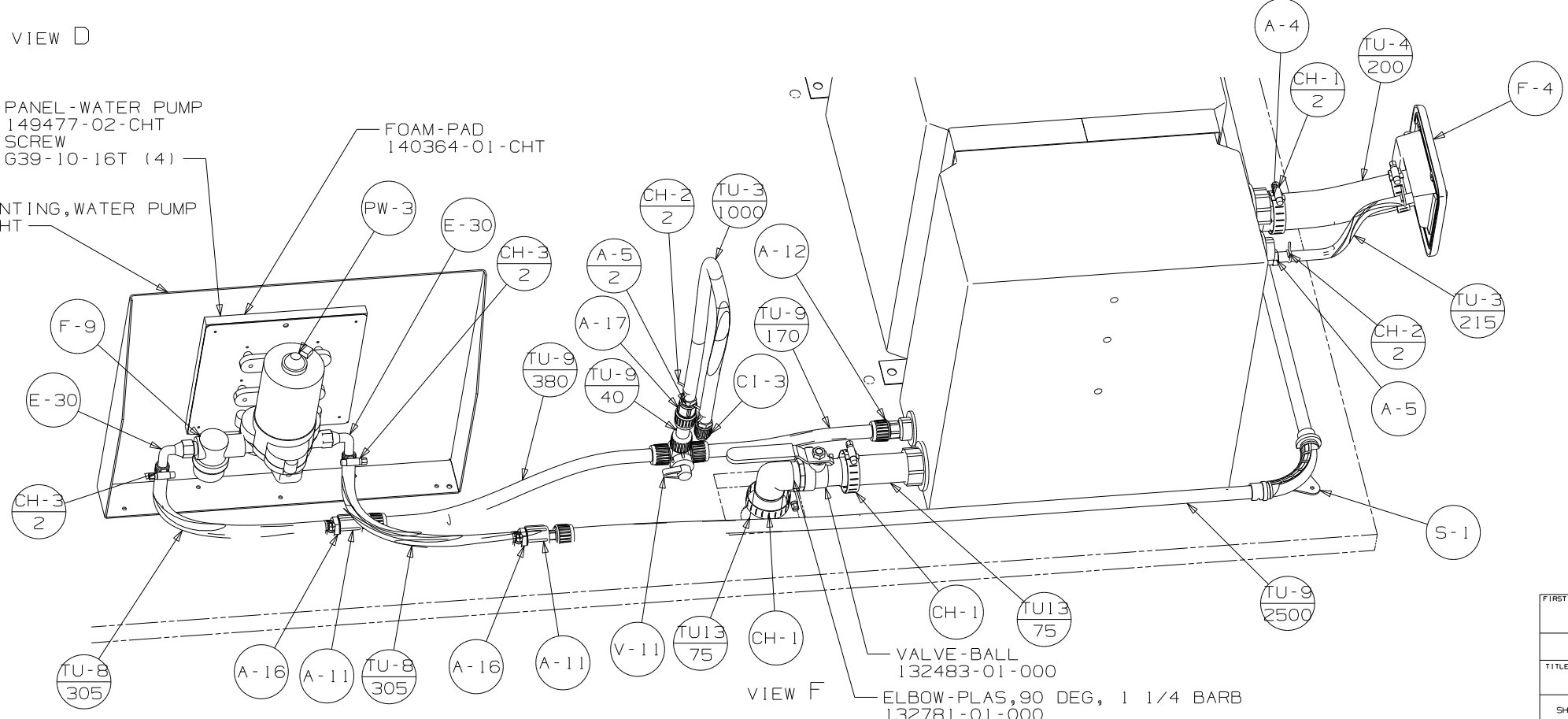

VIEW F

FIRST USED	07 228P
DO NOT SCALE DRAWING	
TITLE	WATER SYSTEM INSTL
SHEET 3	PART NO 158440 REV