



DANGER

Danger of electrical shock, burns or death. Always remove all power sources before attempting any repair, service or diagnostic work. Power can be present from shore power, generator, inverter or battery. All power sources must be disabled and secured before performing any service.



CAUTION

If you lack the skills, tools or equipment to perform diagnostic or repair work leave such work to an authorized Winnebago Industries dealer or other qualified shop.

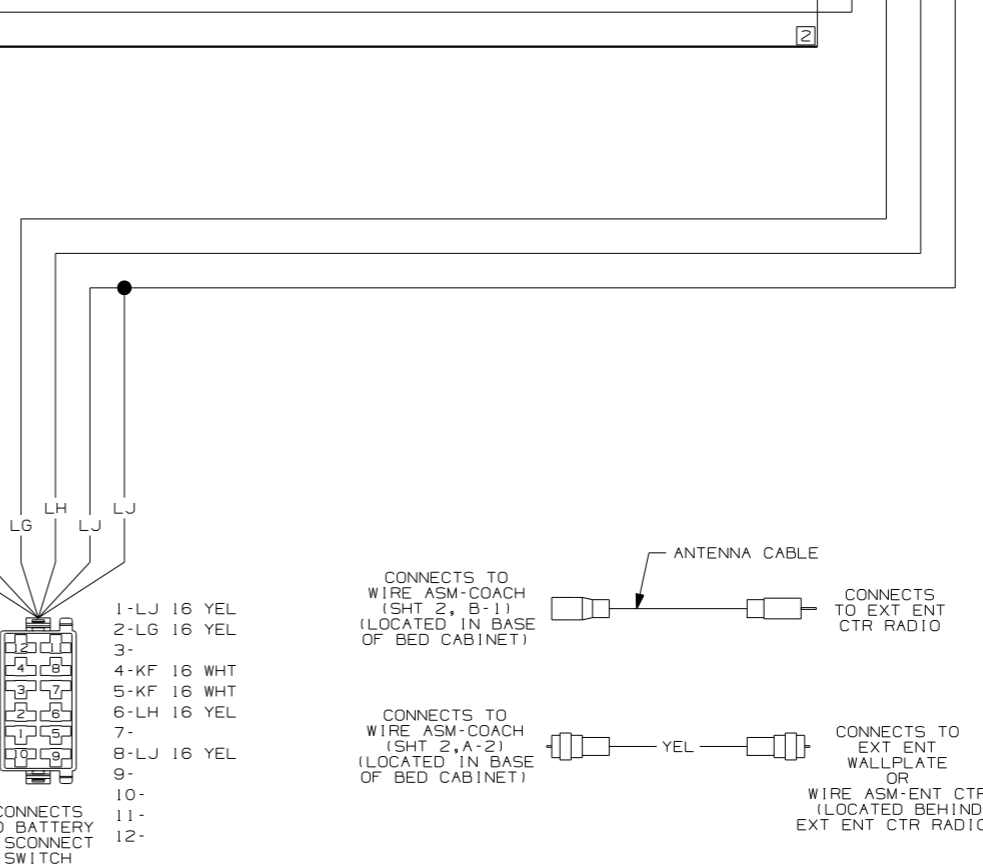
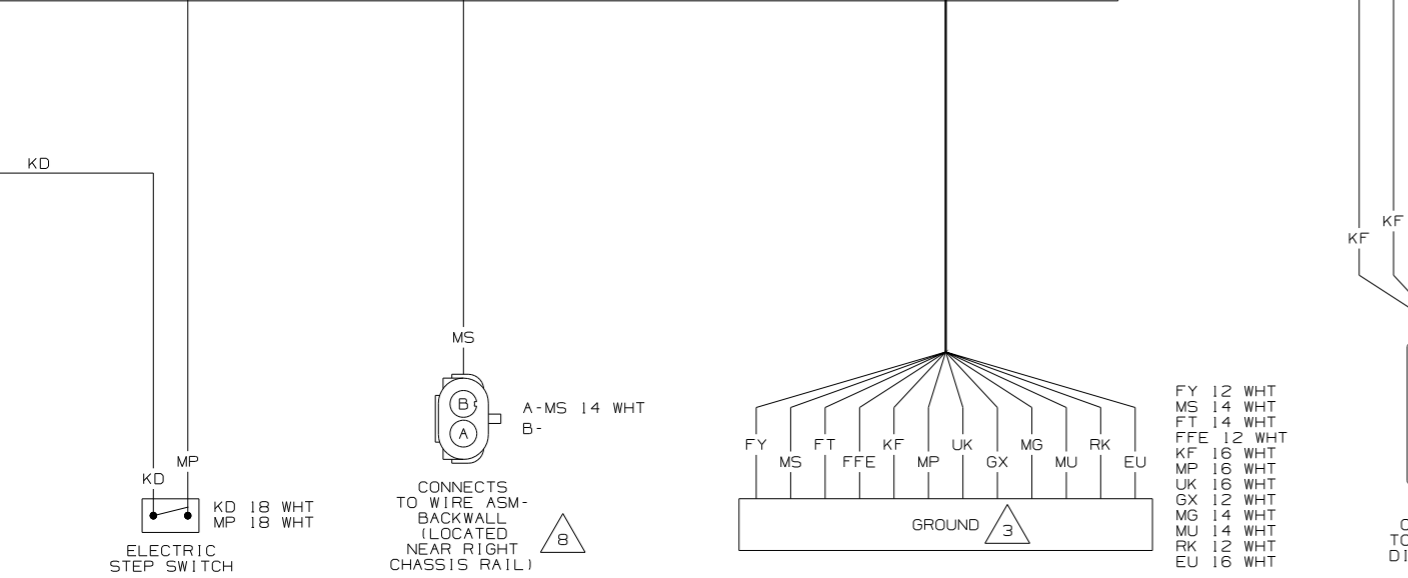
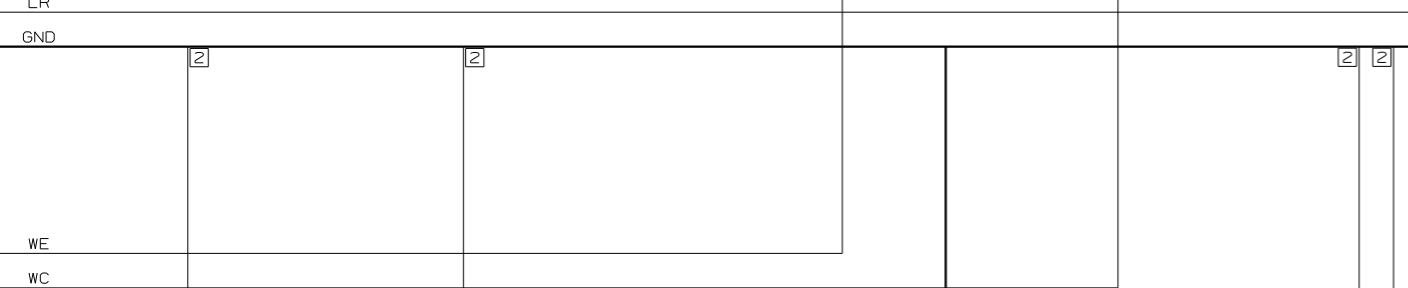
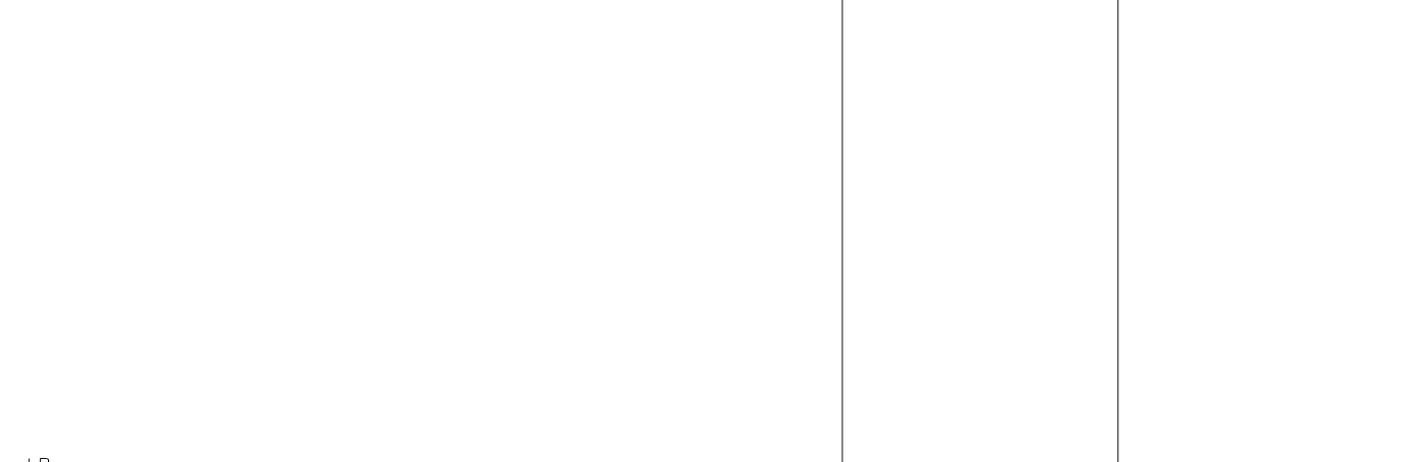
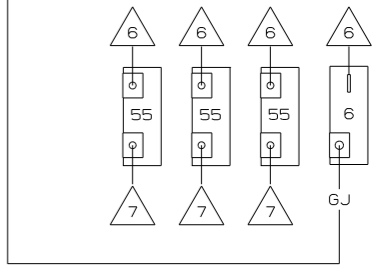
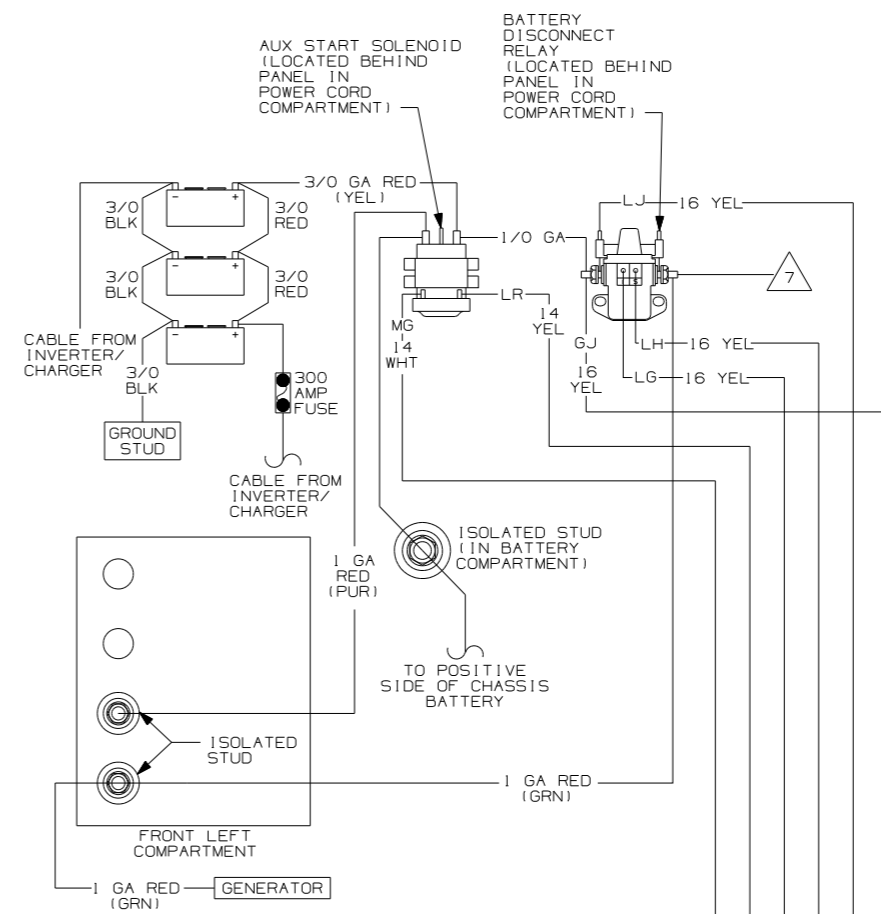
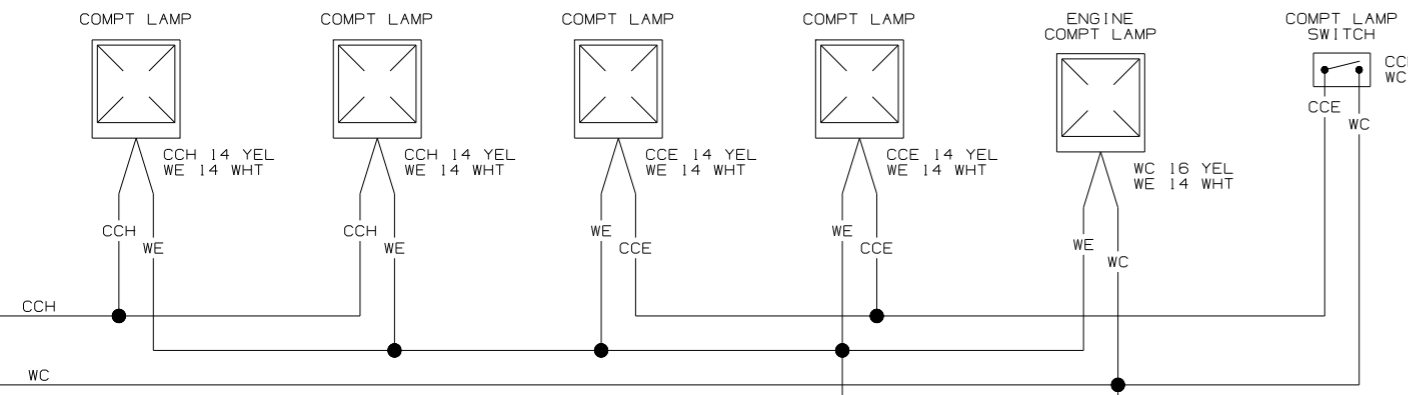

WIRING DIAGRAM-CHASSIS
 (WIRE ASM 153934 REV-E)

WINNEBAGO COPYRIGHT 2004 WINNEBAGO INDUSTRIES, INC.

DFTR	ORIG. DATE
CHNR	ALL DIMENSIONS ARE IN MILLIMETERS
P.E.	
M.E.	FIRST USED
DSNR	06 S36RD

UNSPECIFIED TOLERANCES ARE: MATERIAL:

WHOLE DIM (XX) :
 ONE-PLACE (X,XX) :
 TWO-PLACE (X,XX) :
 ANGLE :

THIRD ANGLE PROJECTION

DO NOT SCALE DRAWING

TITLE: WIRING DIAGRAM-BODY, 12V
 SHEET 1 of 8 PART NO 153937

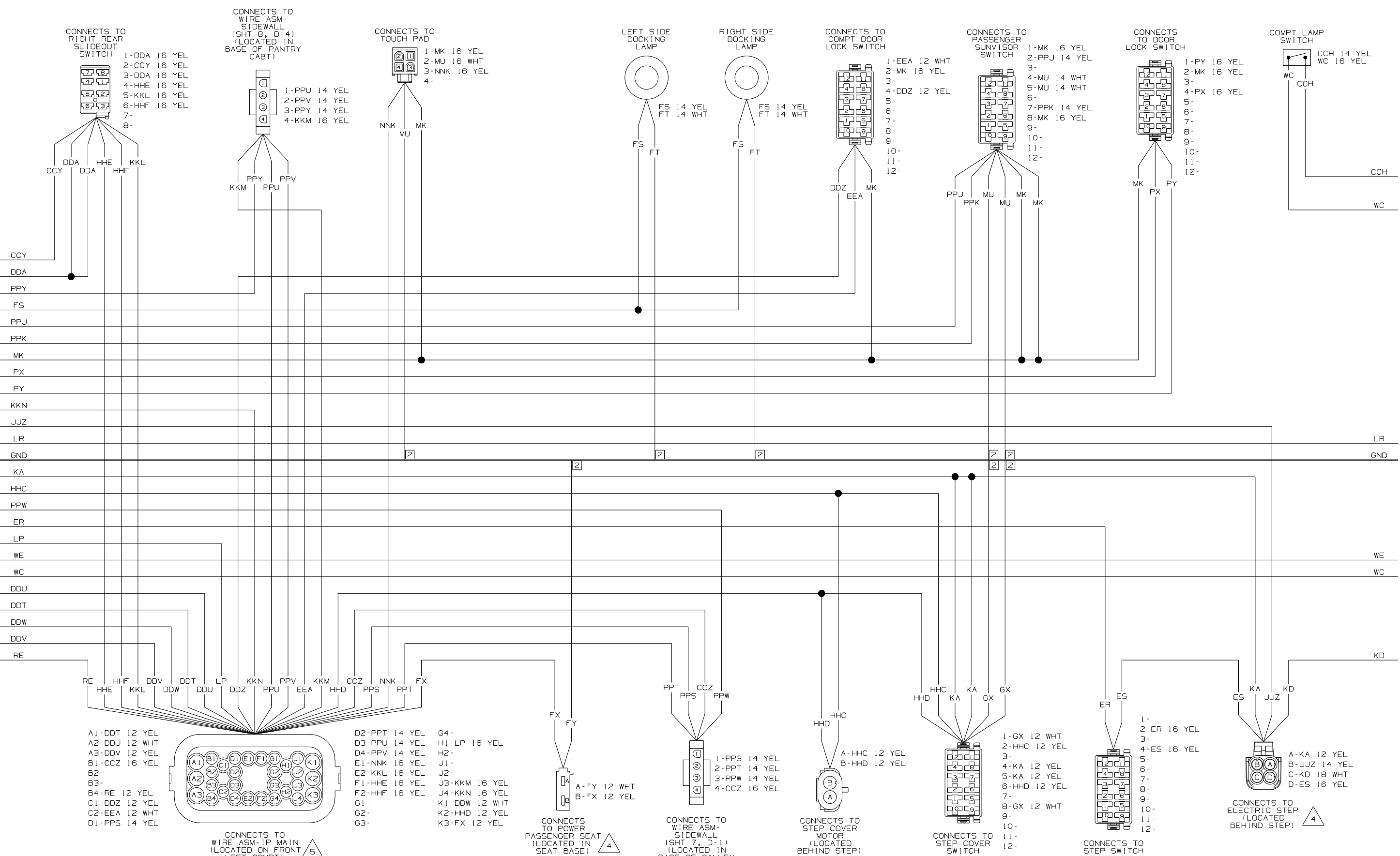

CONNECTS TO AWNING CONTROL BOX

CONNECTS TO WIRE ASM-SIDEWALL (SHT 8, B-6) (LOCATED IN PASSENGERS CONSOLE)

CONNECTS TO AWNING CONTROL BOX

CONNECTS TO AWNING CONTROL BOX

CONNECTS TO WIRE ASM-IP MAIN (LOCATED ON FRONT LEFT COMPT)

CONNECTS TO LEFT REAR SLIDEOUT SWITCH

- 1-FFH 12 YEL
- 2-FFJ 12 WHT

- 1-PJ 16 YEL
- 2-PM 14 WHT
- 3-FFF 12 YEL
- 4-FFG 12 WHT
- 5-FFH 12 YEL
- 6-FFJ 12 WHT
- 7-RRT 16 YEL
- 8-HA 14 YEL
- 9-RRU 16 WHT

- 1-RRT 16 YEL
- 2-RRU 16 WHT

- 1-FFD 12 YEL
- 2-FFE 12 WHT
- 3-
- 4-JJZ 14 YEL

- A1-
- A2-HHC 12 YEL
- A3-FS 14 YEL
- B1-BBM 16 YEL
- B2-BBN 16 YEL
- B3-CCY 16 YEL
- B4-KKK 16 YEL
- C1-DDA 16 YEL
- C2-PPJ 14 YEL
- D1-LL 16 WHT

- D2-LM 16 WHT
- D3-LN 16 WHT
- D4-HU 16 YEL
- E1-MM 14 YEL
- E2-WC 16 YEL
- F1-MK 16 YEL
- F2-LR 14 YEL
- G1-PPW 14 YEL
- G2-
- G3-PPY 14 YEL

- G4-
- H1-PPK 14 YEL
- H2-PX 16 YEL
- J1-PJ 16 YEL
- J2-JJZ 14 YEL
- J3-ER 16 YEL
- J4-PY 16 YEL
- K1-FFD 12 YEL
- K2-KA 12 YEL
- K3-

- 1-DDA 16 YEL
- 2-CCY 16 YEL
- 3-DDA 16 YEL
- 4-BBM 16 YEL
- 5-KKK 16 YEL
- 6-BBN 16 YEL
- 7-
- 8-

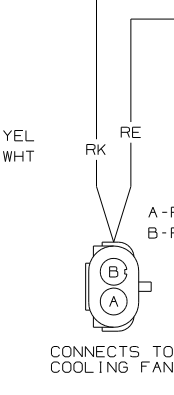
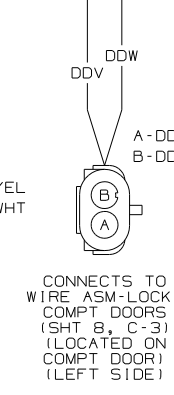
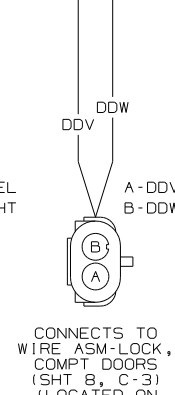
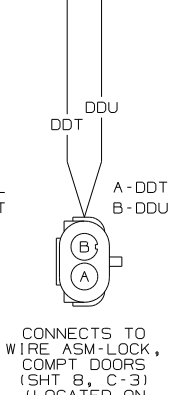
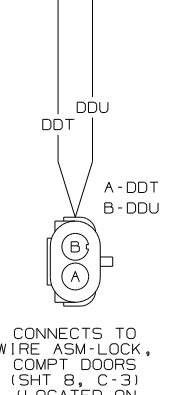
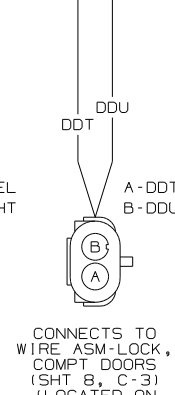
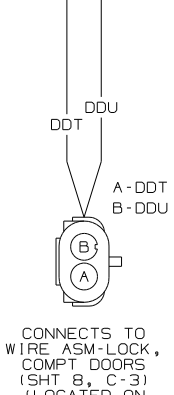
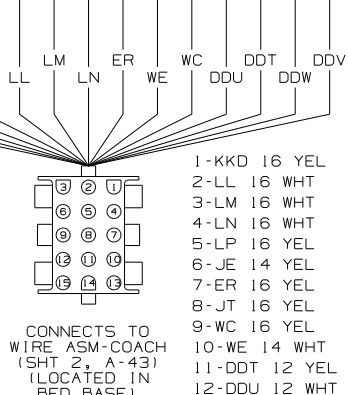
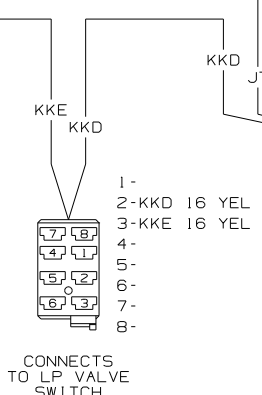
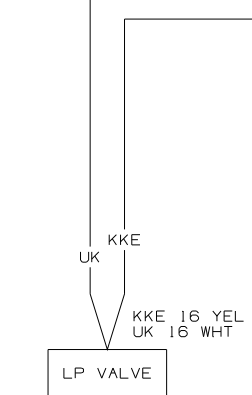
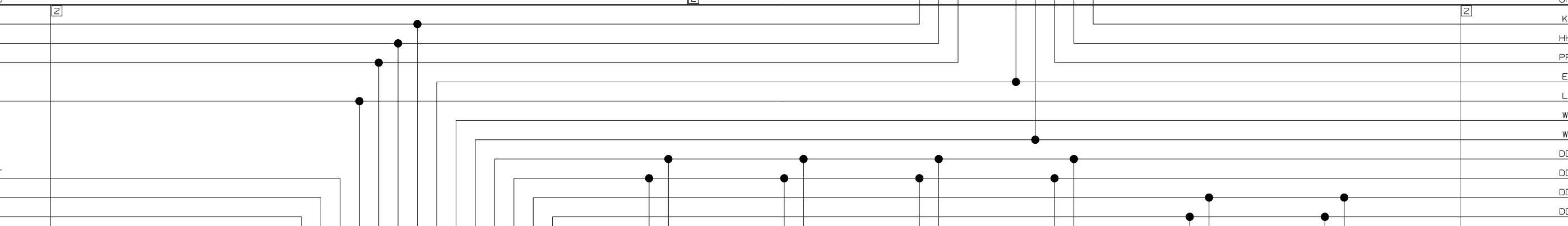
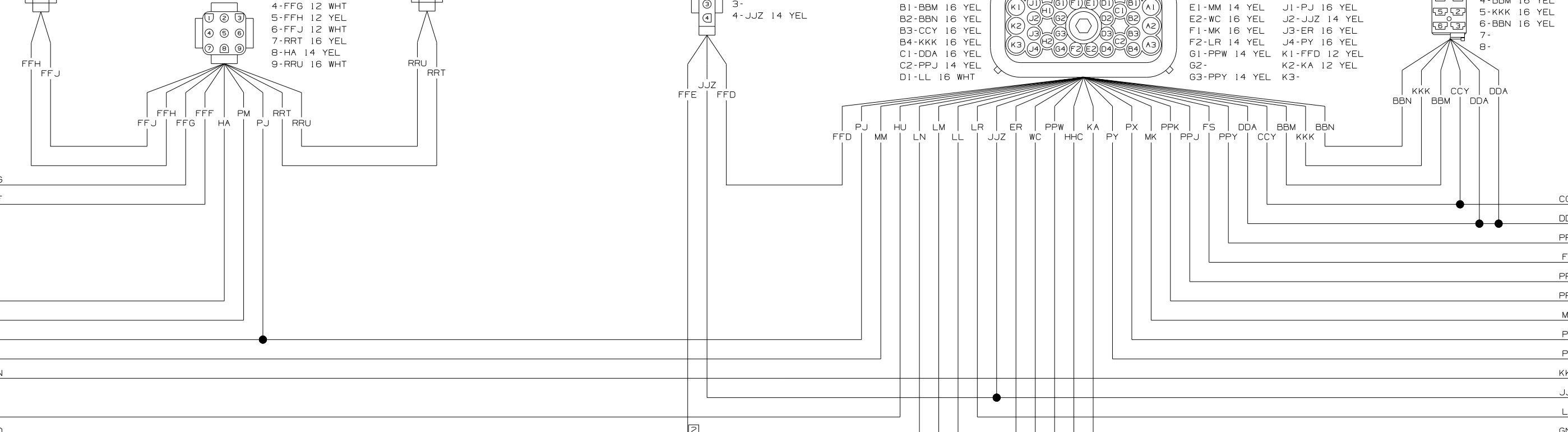
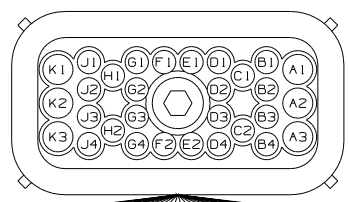

- 1-KKD 16 YEL
- 2-LL 16 WHT
- 3-LM 16 WHT
- 4-LN 16 WHT
- 5-LP 16 YEL
- 6-JE 14 YEL
- 7-ER 16 YEL
- 8-JT 16 YEL
- 9-WC 16 YEL
- 10-WE 14 WHT
- 11-DDT 12 YEL
- 12-DDU 12 WHT
- 13-DDV 12 YEL
- 14-DDW 12 WHT
- 15-JJT 14 YEL

- 1-KKD 16 YEL
- 2-LL 16 WHT
- 3-LM 16 WHT
- 4-LN 16 WHT
- 5-LP 16 YEL
- 6-JE 14 YEL
- 7-ER 16 YEL
- 8-JT 16 YEL
- 9-WC 16 YEL
- 10-WE 14 WHT
- 11-DDT 12 YEL
- 12-DDU 12 WHT
- 13-DDV 12 YEL
- 14-DDW 12 WHT
- 15-JJT 14 YEL

- 1-KKD 16 YEL
- 2-LL 16 WHT
- 3-LM 16 WHT
- 4-LN 16 WHT
- 5-LP 16 YEL
- 6-JE 14 YEL
- 7-ER 16 YEL
- 8-JT 16 YEL
- 9-WC 16 YEL
- 10-WE 14 WHT
- 11-DDT 12 YEL
- 12-DDU 12 WHT
- 13-DDV 12 YEL
- 14-DDW 12 WHT
- 15-JJT 14 YEL

- 1-KKD 16 YEL
- 2-LL 16 WHT
- 3-LM 16 WHT
- 4-LN 16 WHT
- 5-LP 16 YEL
- 6-JE 14 YEL
- 7-ER 16 YEL
- 8-JT 16 YEL
- 9-WC 16 YEL
- 10-WE 14 WHT
- 11-DDT 12 YEL
- 12-DDU 12 WHT
- 13-DDV 12 YEL
- 14-DDW 12 WHT
- 15-JJT 14 YEL

- 1-KKD 16 YEL
- 2-LL 16 WHT
- 3-LM 16 WHT
- 4-LN 16 WHT
- 5-LP 16 YEL
- 6-JE 14 YEL
- 7-ER 16 YEL
- 8-JT 16 YEL
- 9-WC 16 YEL
- 10-WE 14 WHT
- 11-DDT 12 YEL
- 12-DDU 12 WHT
- 13-DDV 12 YEL
- 14-DDW 12 WHT
- 15-JJT 14 YEL

- 1-KKD 16 YEL
- 2-LL 16 WHT
- 3-LM 16 WHT
- 4-LN 16 WHT
- 5-LP 16 YEL
- 6-JE 14 YEL
- 7-ER 16 YEL
- 8-JT 16 YEL
- 9-WC 16 YEL
- 10-WE 14 WHT
- 11-DDT 12 YEL
- 12-DDU 12 WHT
- 13-DDV 12 YEL
- 14-DDW 12 WHT
- 15-JJT 14 YEL

- 1-KKD 16 YEL
- 2-LL 16 WHT
- 3-LM 16 WHT
- 4-LN 16 WHT
- 5-LP 16 YEL
- 6-JE 14 YEL
- 7-ER 16 YEL
- 8-JT 16 YEL
- 9-WC 16 YEL
- 10-WE 14 WHT
- 11-DDT 12 YEL
- 12-DDU 12 WHT
- 13-DDV 12 YEL
- 14-DDW 12 WHT
- 15-JJT 14 YEL

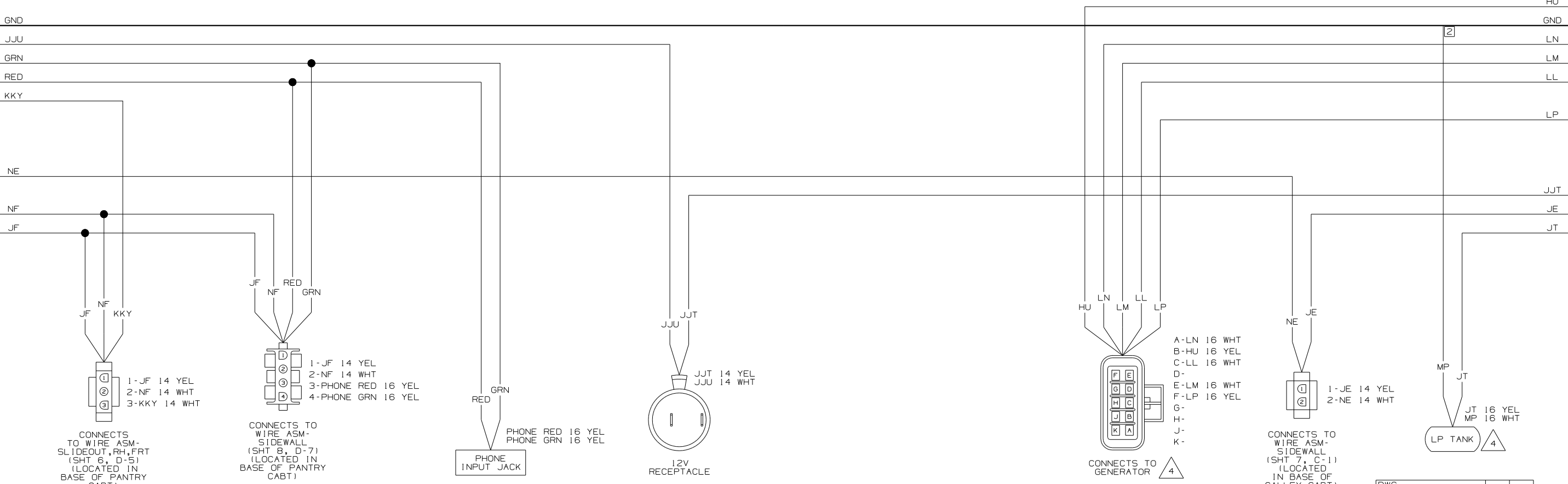
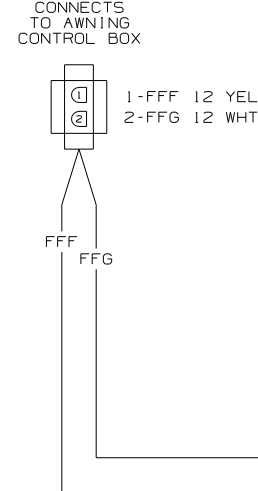
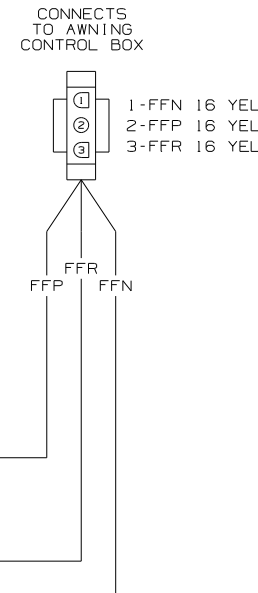
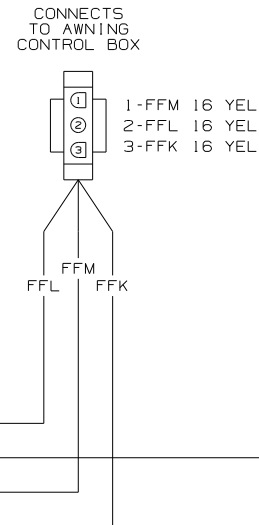
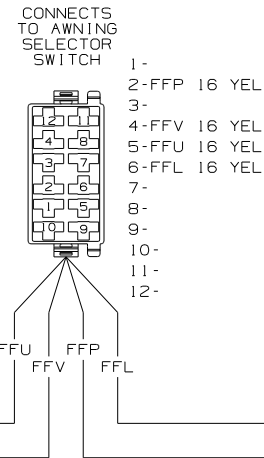
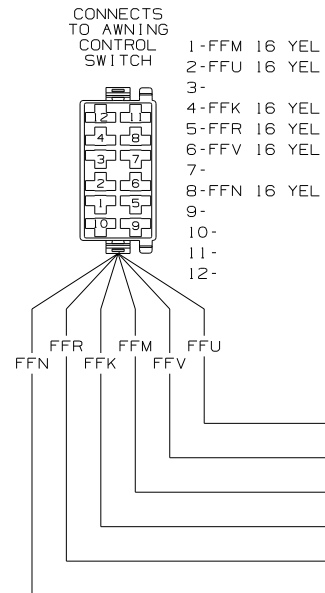
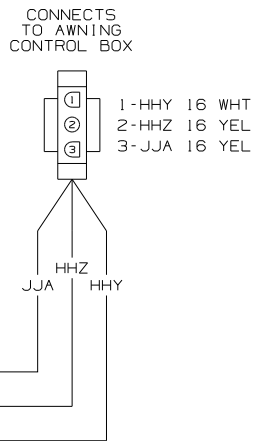
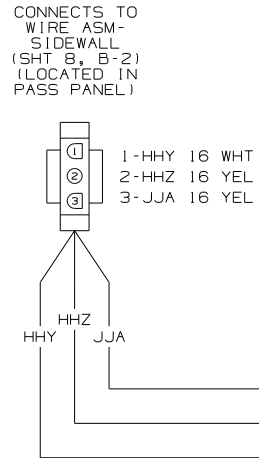
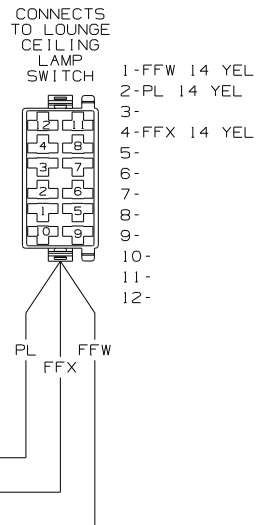

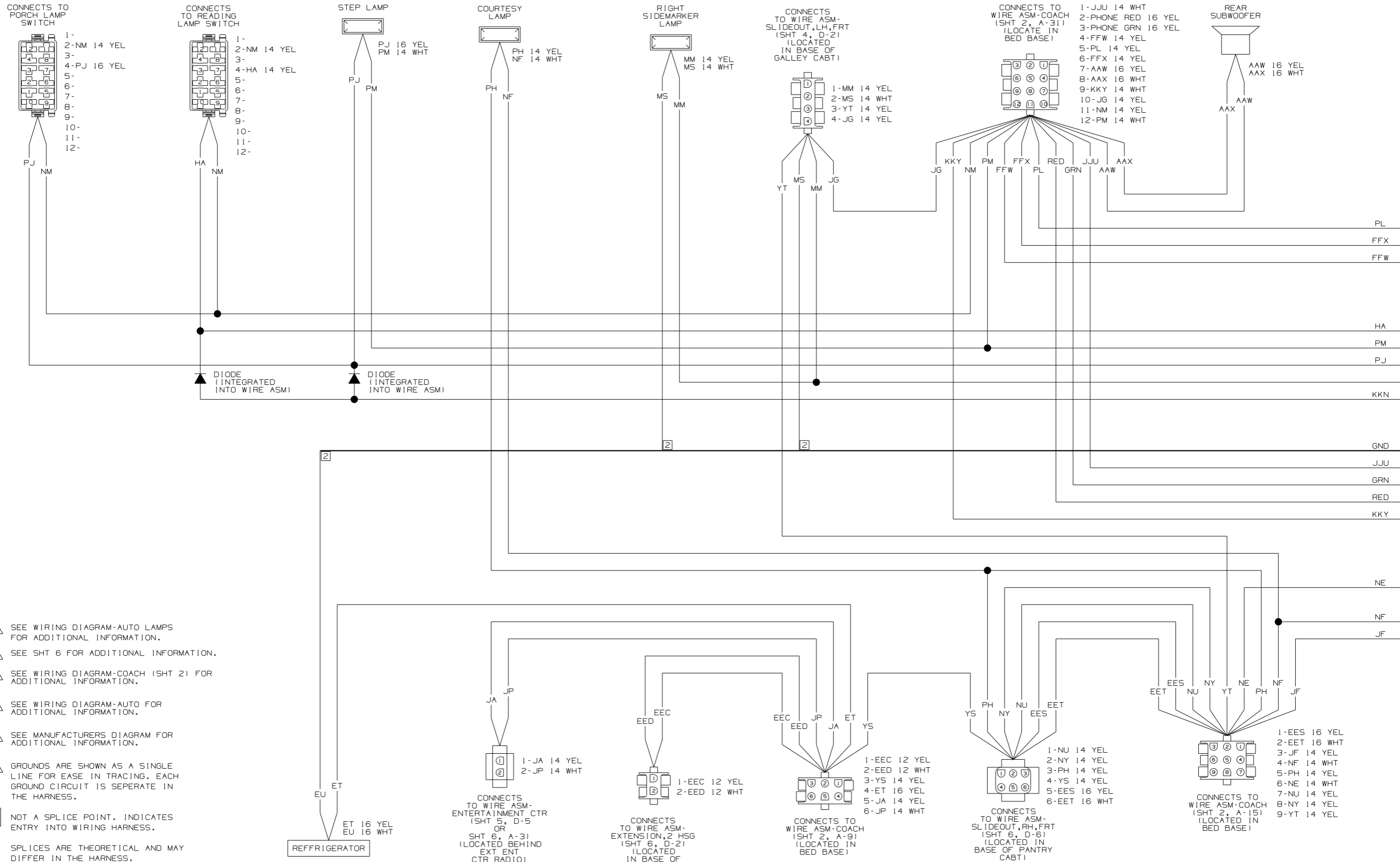

- 8 SEE WIRING DIAGRAM-AUTO LAMPS FOR ADDITIONAL INFORMATION.
 - 7 SEE SHT 6 FOR ADDITIONAL INFORMATION.
 - 6 SEE WIRING DIAGRAM-COACH (SHT 2) FOR ADDITIONAL INFORMATION.
 - 5 SEE WIRING DIAGRAM-AUTO FOR ADDITIONAL INFORMATION.
 - 4 SEE MANUFACTURERS DIAGRAM FOR ADDITIONAL INFORMATION.
 - 3 GROUNDS ARE SHOWN AS A SINGLE LINE FOR EASE IN TRACING. EACH GROUND CIRCUIT IS SEPERATE IN THE HARNESS.
 - 2 NOT A SPLICE POINT. INDICATES ENTRY INTO WIRING HARNESS.
- NOTES:
- SPLICES ARE THEORETICAL AND MAY DIFFER IN THE HARNESS.

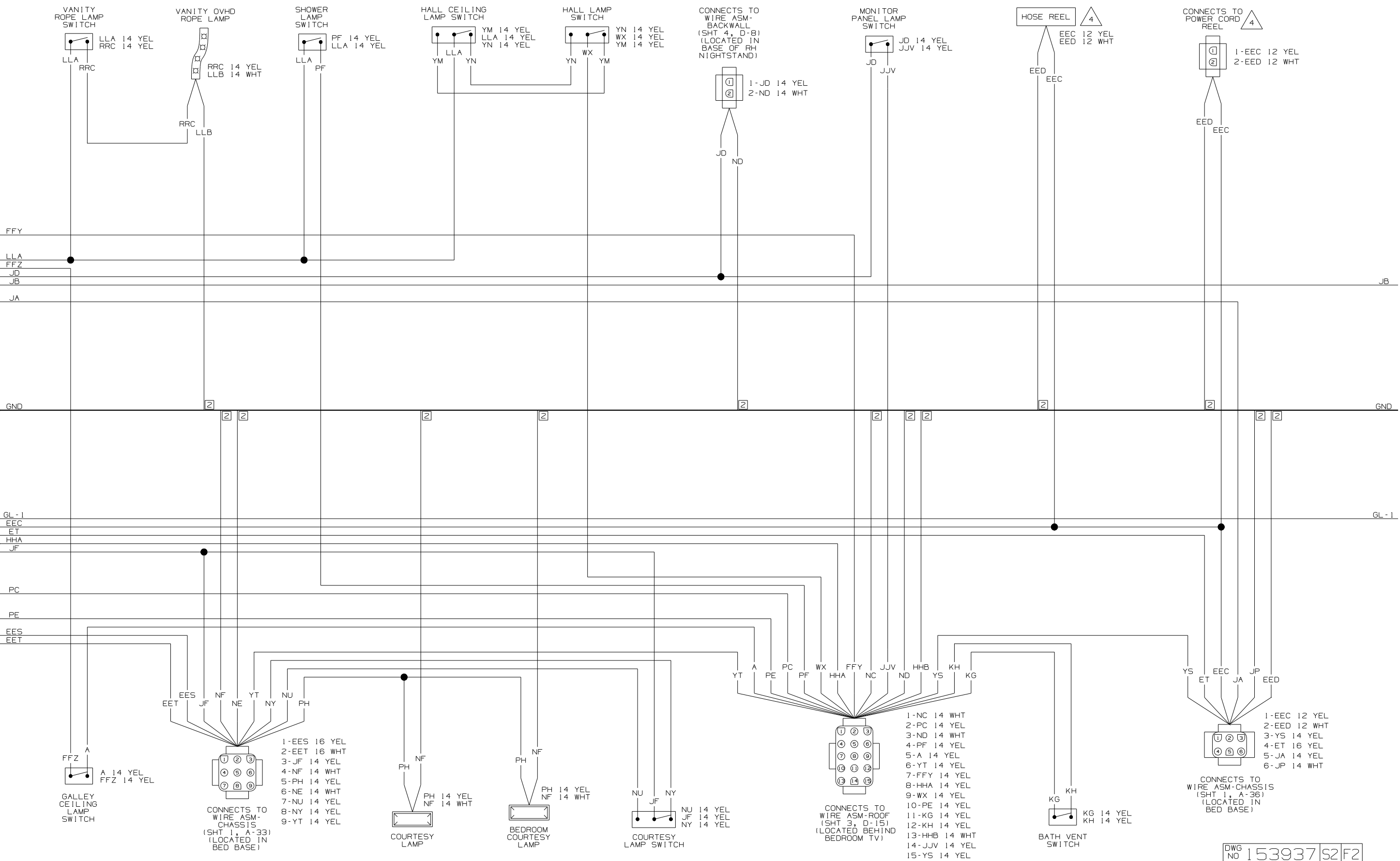

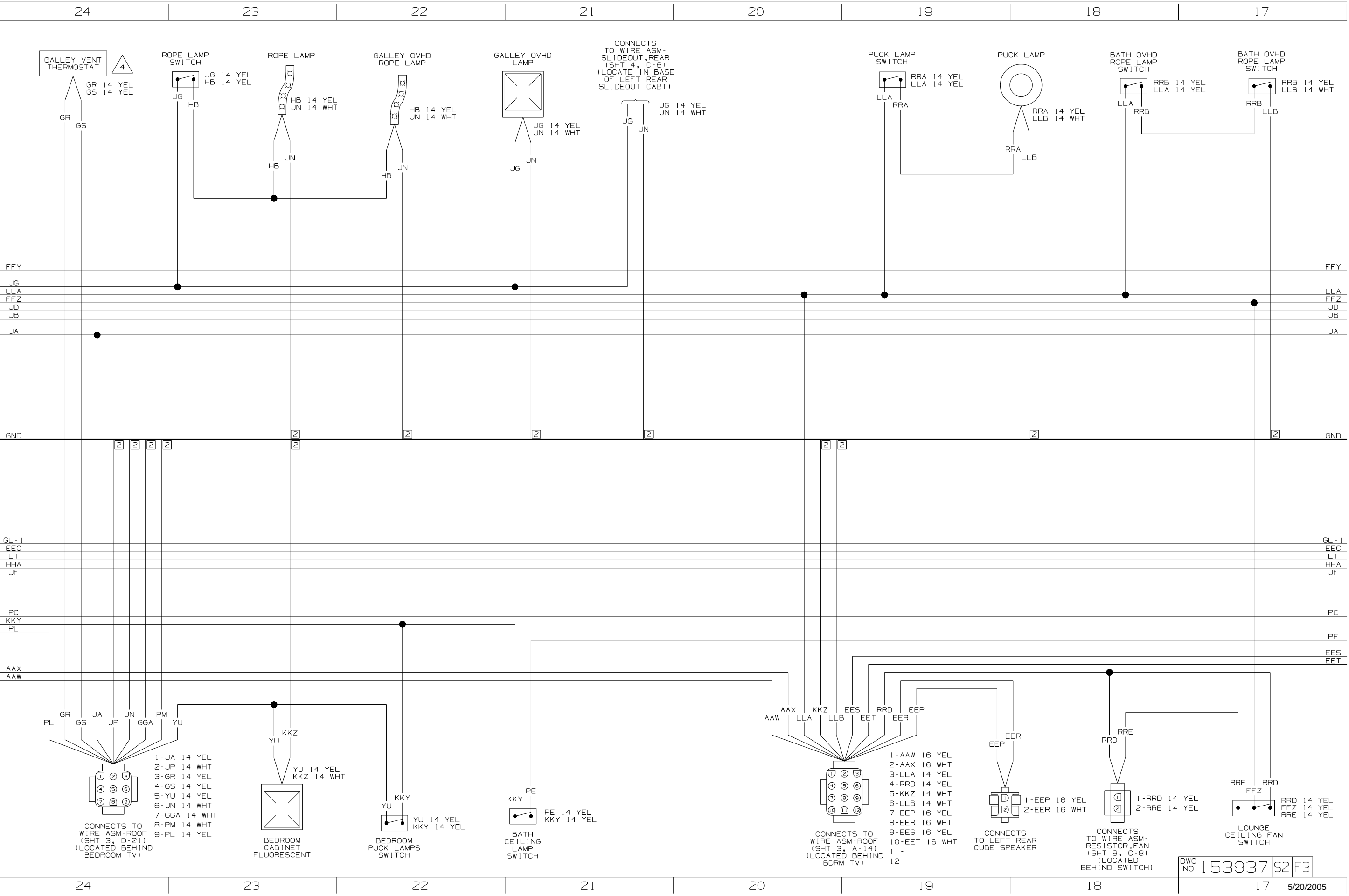

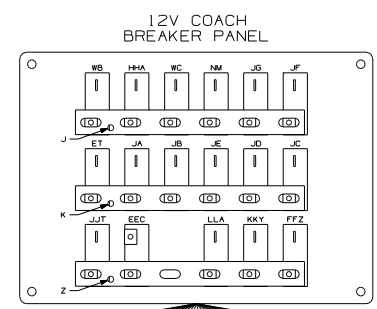

- J 6 BLK
- K 6 BLK
- Z 6 BLK
- WB 16 YEL
- HHA 14 YEL
- WC 14 YEL
- NM 14 YEL
- JG 14 YEL
- JF 14 YEL
- ET 16 YEL
- JA 12 YEL
- JB 14 YEL
- JE 14 YEL
- JD 14 YEL
- JC 14 YEL
- JJT 14 YEL
- EEC 12 YEL
- LLA 14 YEL
- KKY 14 YEL
- FFZ 14 YEL
- z

12V CHASSIS BREAKER PANEL (LOCATED IN POWERCORD COMPT)

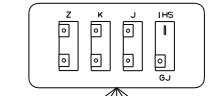

- Z 6 BLK
- K 6 BLK
- J 6 BLK
- IHS 16 YEL
- GJ 16 YEL

CONNECTS TO SOLAR CHARGER INDICATOR LAMP



SUBWOOFER



CONNECTS TO WIRE ASM-REAR STEREO (SHT 5, C-3) (LOCATED IN BASE OF BDRM NIGHTSTAND)

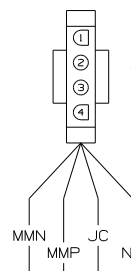

FAN SWITCH

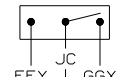

CONNECTS TO WIRE ASM-RESISTOR, FAN (SHT 8, C-8) (LOCATED BEHIND SWITCH)

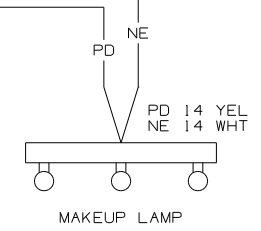
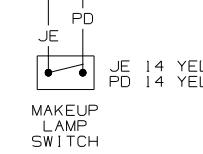
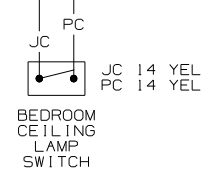
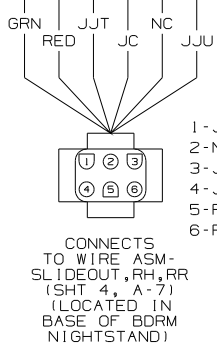
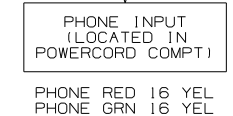
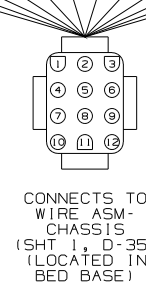
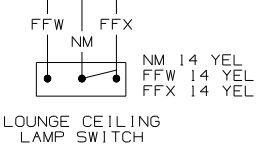
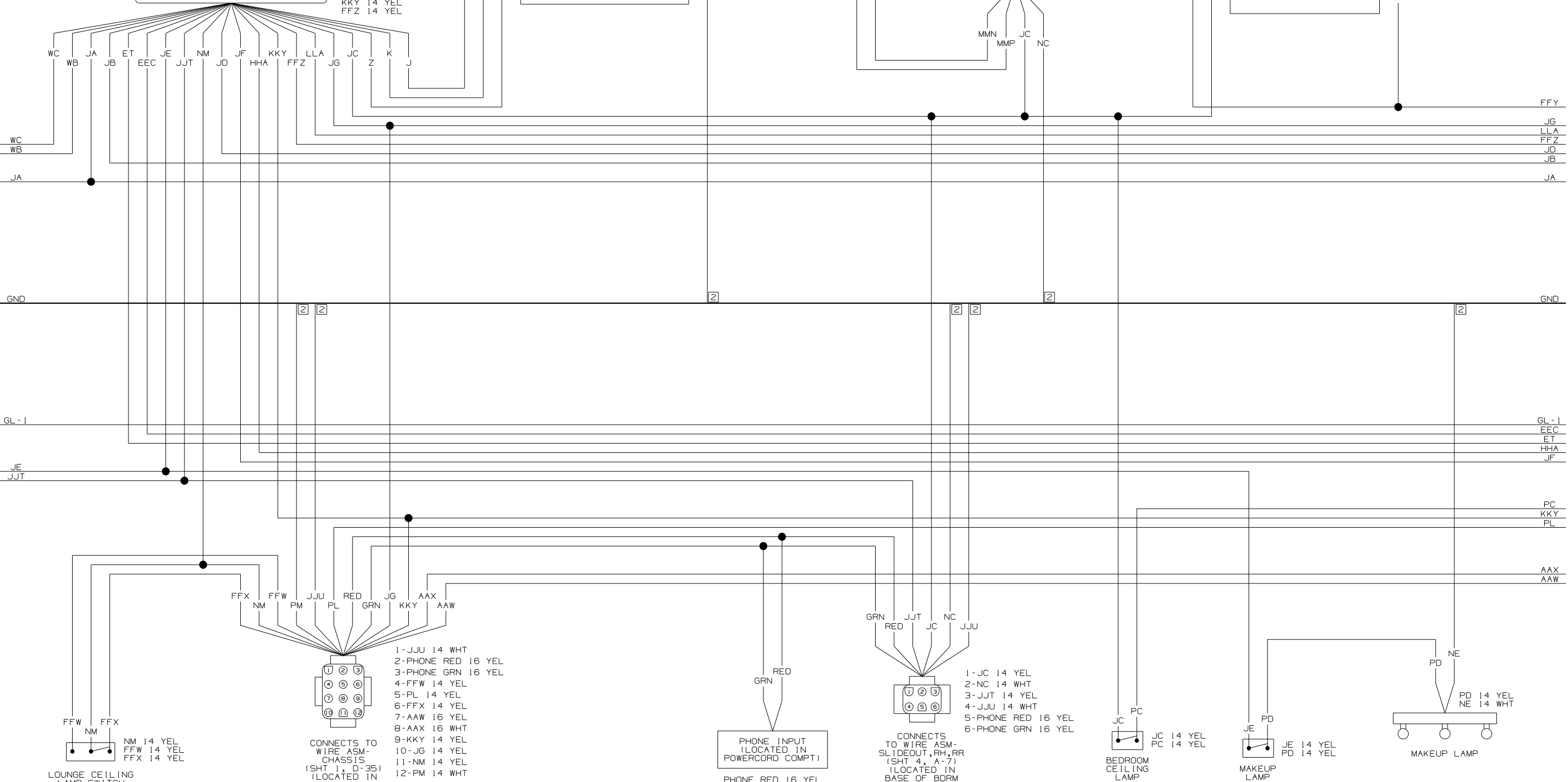

CONNECTS TO LOAD SHEDDER CONTROL BOARD (LOCATED IN 110V PANEL)



- 1-JA 14 YEL
- 2-JP 14 WHT
- 3-CCN 16 YEL
- 4-BBJ 16 YEL
- 5-DD 16 YEL
- 6-BBH 16 YEL
- 7-CCP 16 YEL
- 8-LP 16 YEL

CONNECTS TO A/C CORD (LOCATED BEHIND THERMOSTAT)



- 1-BBH 16 YEL
- 2-CCP 16 YEL

CONNECTS TO A/C CORD (LOCATED BEHIND THERMOSTAT)



- 1-1GREY 16 YEL
- 2-RED 16 YEL
- 3-2GREY 16 YEL
- 4-BLUE 16 YEL
- 5-YELLOW 16 YEL
- 6-CCP-1 16 YEL
- 7-DD 16 YEL
- 8-WHITE 16 YEL
- 9-CCN 16 YEL

CONNECTS TO A/C CORD (LOCATED BEHIND THERMOSTAT)



- 1-BBH-1 16 YEL
- 2-CCP-1 16 YEL

CONNECTS TO THERMOSTAT



- 1GREY 2GREY YELLOW CCN
- BBH-1 RED BLUE WHITE BBJ

CONNECTS TO MONITOR PANEL SWITCH



- 1-BBY 14 YEL
- 2-CCR 14 YEL
- 3-
- 4-
- 5-
- 6-
- 7-
- 8-

CONNECTS TO EXTERIOR MONITOR PANEL



- 1-BBY 14 YEL
- 2-CCR 14 YEL
- 3-JA 14 YEL
- 4-CCD 16 YEL
- 5-CCN 16 YEL
- 6-CCB 16 YEL
- 7-JP 14 WHT
- 8-
- 9-

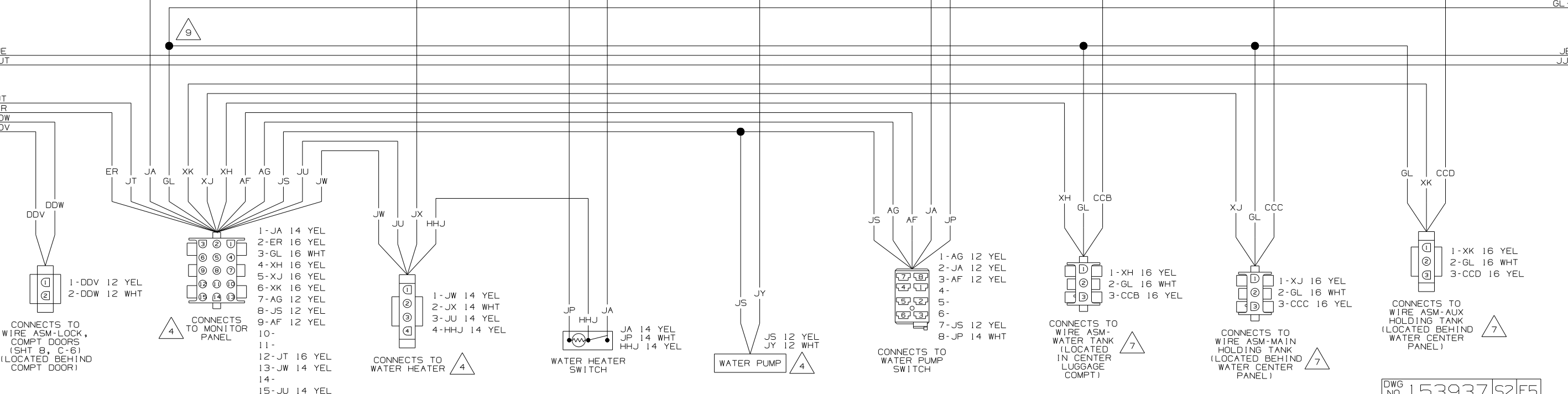
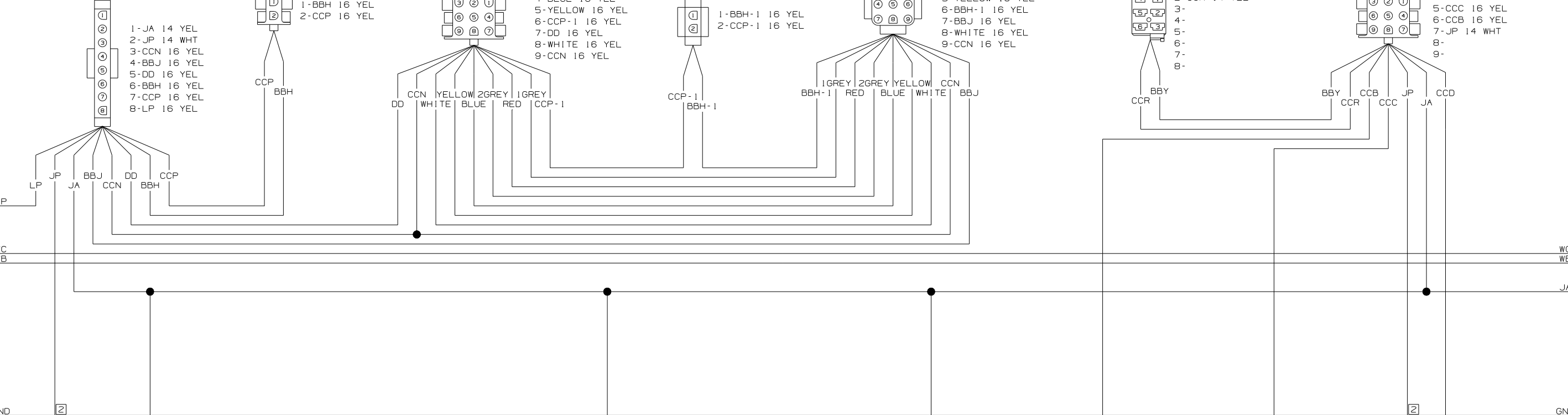

CONNECTS TO WIRE ASM-LOCK, COMPT DOORS (SHT 8, C-6) (LOCATED BEHIND COMPT DOOR)



- 1-JA 14 YEL
- 2-ER 16 YEL
- 3-GL 16 WHT
- 4-XH 16 YEL
- 5-XJ 16 YEL
- 6-XK 16 YEL
- 7-AG 12 YEL
- 8-JS 12 YEL
- 9-AF 12 YEL
- 10-
- 11-
- 12-JT 16 YEL
- 13-JW 14 YEL
- 14-
- 15-JU 14 YEL

CONNECTS TO WATER HEATER



- 1-JW 14 YEL
- 2-JX 14 WHT
- 3-JU 14 YEL
- 4-HHJ 14 YEL

WATER HEATER SWITCH



- JA 14 YEL
- JP 14 WHT
- HHJ 14 YEL

CONNECTS TO WATER PUMP SWITCH



- 1-AG 12 YEL
- 2-JA 12 YEL
- 3-AF 12 YEL
- 4-
- 5-
- 6-
- 7-JS 12 YEL
- 8-JP 14 WHT

CONNECTS TO WIRE ASM-WATER TANK (LOCATED IN CENTER LUGGAGE COMPT)



- 1-XH 16 YEL
- 2-GL 16 WHT
- 3-CCB 16 YEL

CONNECTS TO WIRE ASM-MAIN HOLDING TANK (LOCATED BEHIND WATER CENTER PANEL)



- 1-XK 16 YEL
- 2-GL 16 WHT
- 3-CCD 16 YEL

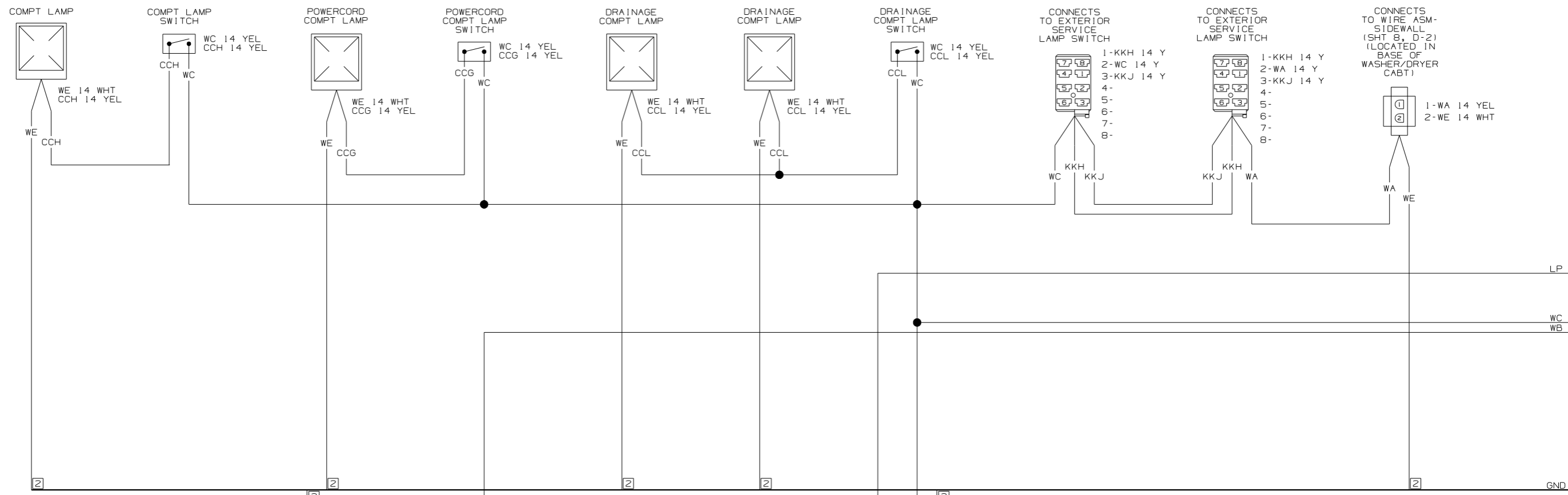

- 9. GL AND GL-1 ARE TO BE SPLICED TOGETHER 100MM AWAY FROM MONITOR PANEL HOUSING FOR ISOLATION PURPOSES.
 - 8. SEE WIRING DIAGRAM-AC/HEAT/EMS FOR ADDITIONAL INFORMATION.
 - 7. SEE WIRING DIAGRAM-HOLDING TANKS FOR ADDITIONAL INFORMATION.
 - 6. SEE WIRING INSTL-BODY, 12V OR WIRING DIAGRAM-CHASSIS FOR ADDITIONAL INFORMATION. (BREAKERS ARE PART OF CHASSIS WIRING.)
 - 5. SEE WIRING DIAGRAM-AUTO FOR ADDITIONAL INFORMATION.
 - 4. SEE MANUFACTURERS DIAGRAM FOR ADDITIONAL INFORMATION.
 - 3. GROUNDS ARE SHOWN AS A SINGLE LINE FOR EASE IN TRACING. EACH GROUND CIRCUIT IS SEPERATE IN THE HARNESS.
 - 2. NOT A SPLICE POINT. INDICATES ENTRY INTO WIRING HARNESS.
1. SPLICES ARE THEORETICAL AND MAY DIFFER IN THE HARNESS.

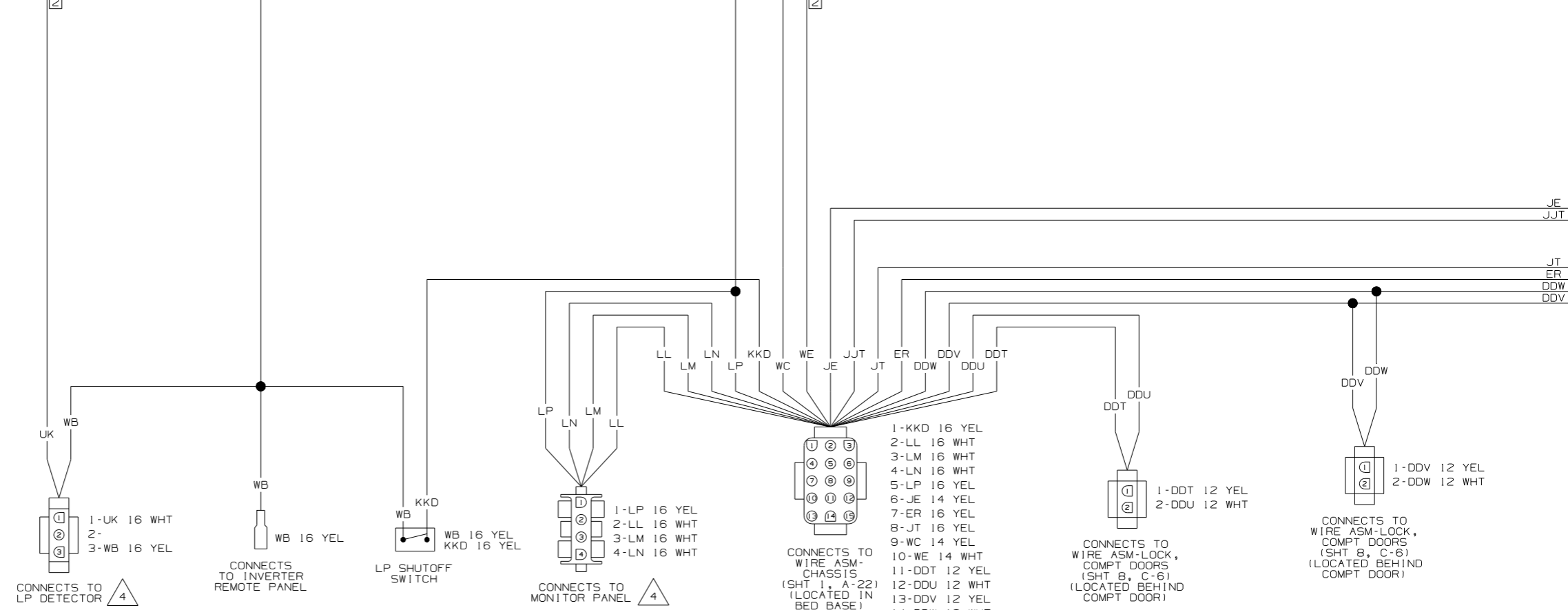

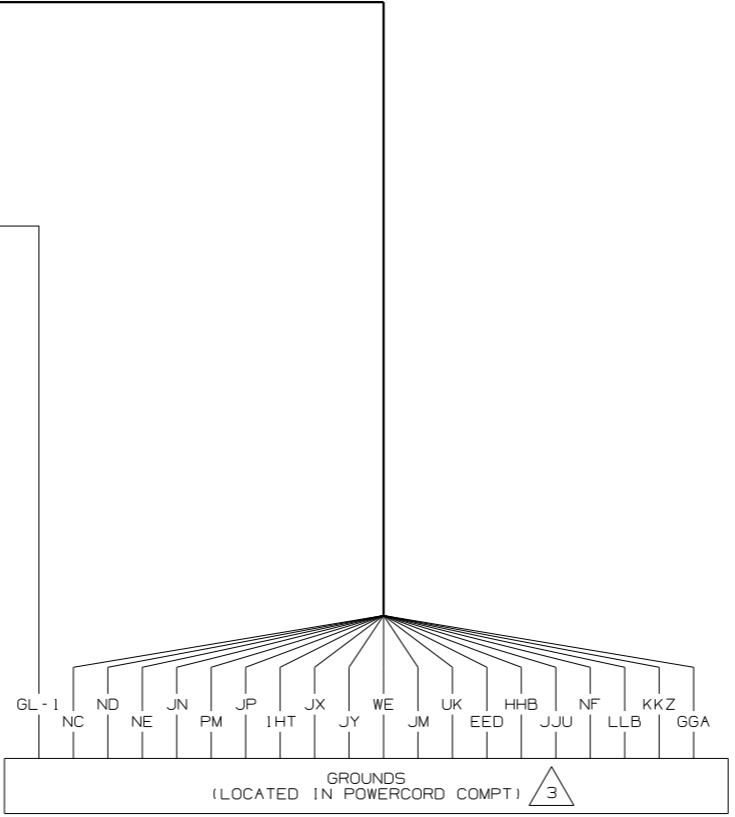
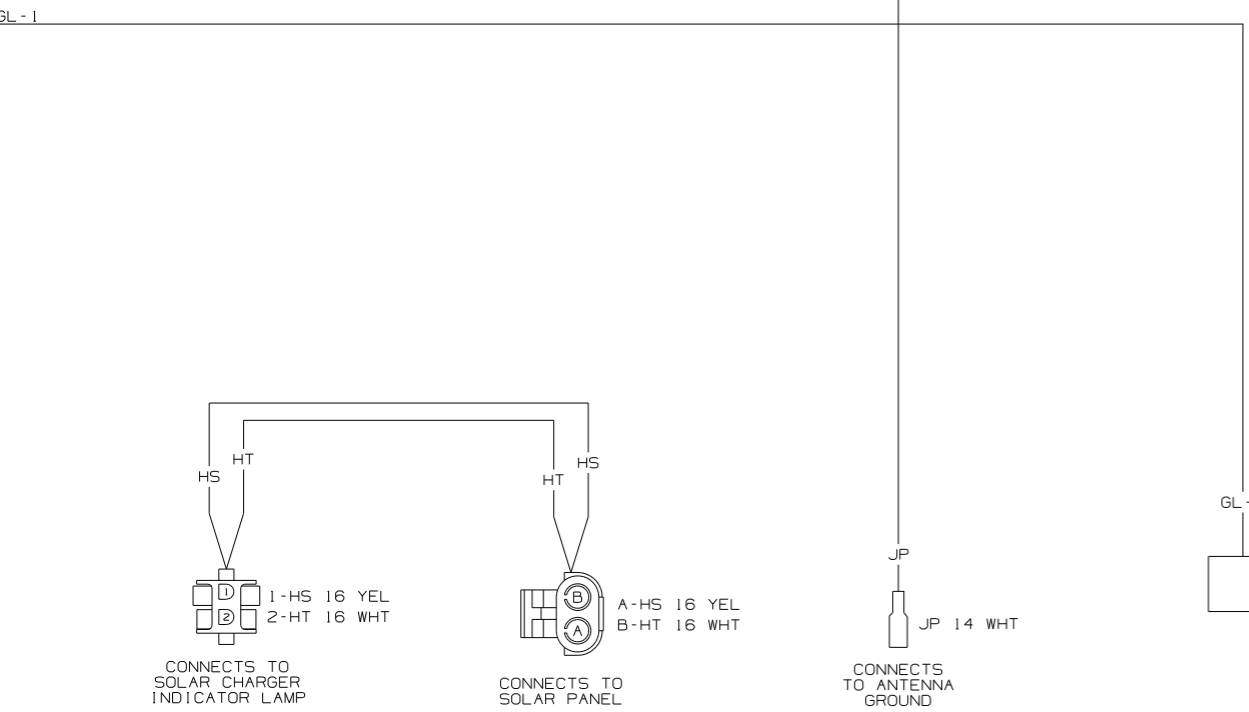
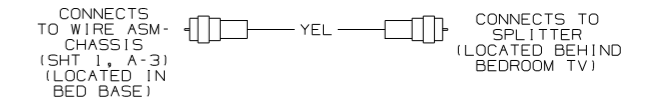
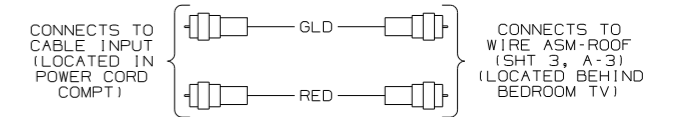
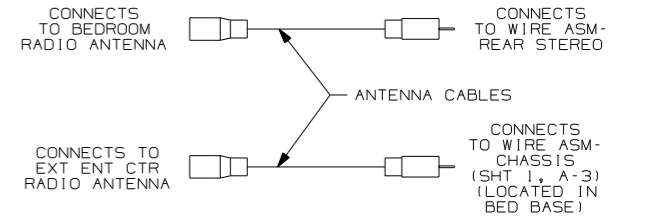
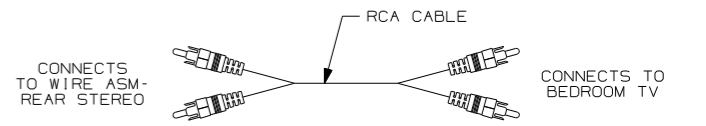
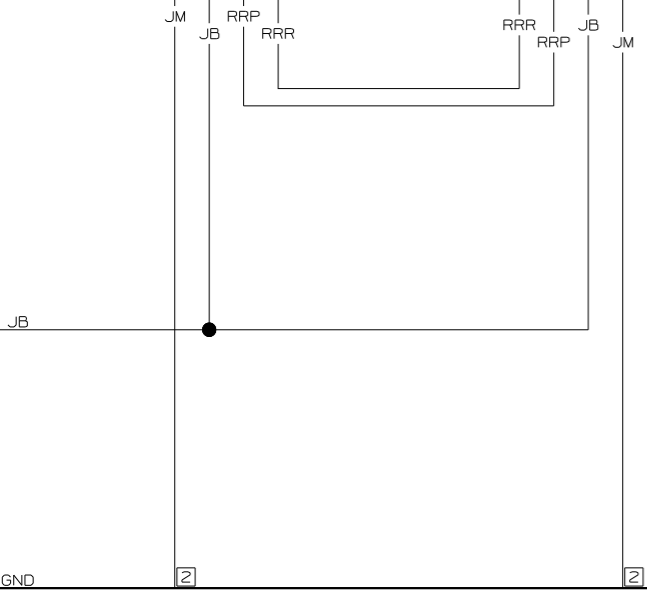
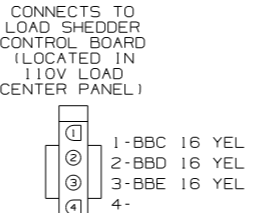
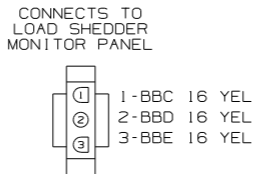
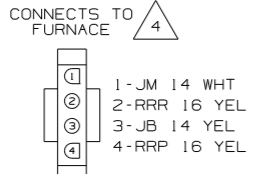
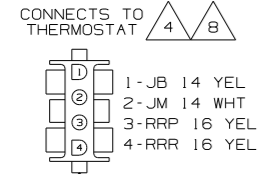

NC 14 WHT	JP 14 WHT	WE 14 WHT	JJU 14 WHT
ND 14 WHT	IHT 16 WHT	JM 14 WHT	NF 14 WHT
NE 14 WHT	GL-1 14 WHT	UK 16 WHT	LLB 14 WHT
JN 14 WHT	JX 14 WHT	EED 12 WHT	KKZ 14 WHT
PM 14 WHT	JY 12 WHT	HHB 14 WHT	GGA 14 WHT

WIRING DIAGRAM-COACH (WIRE ASM 153935 REV-E)

FIRST USED	06 S36RD
DO NOT SCALE DRAWING	
TITLE	WIRING DIAGRAM-BODY, 12V
SHEET 2	PART NO 153937

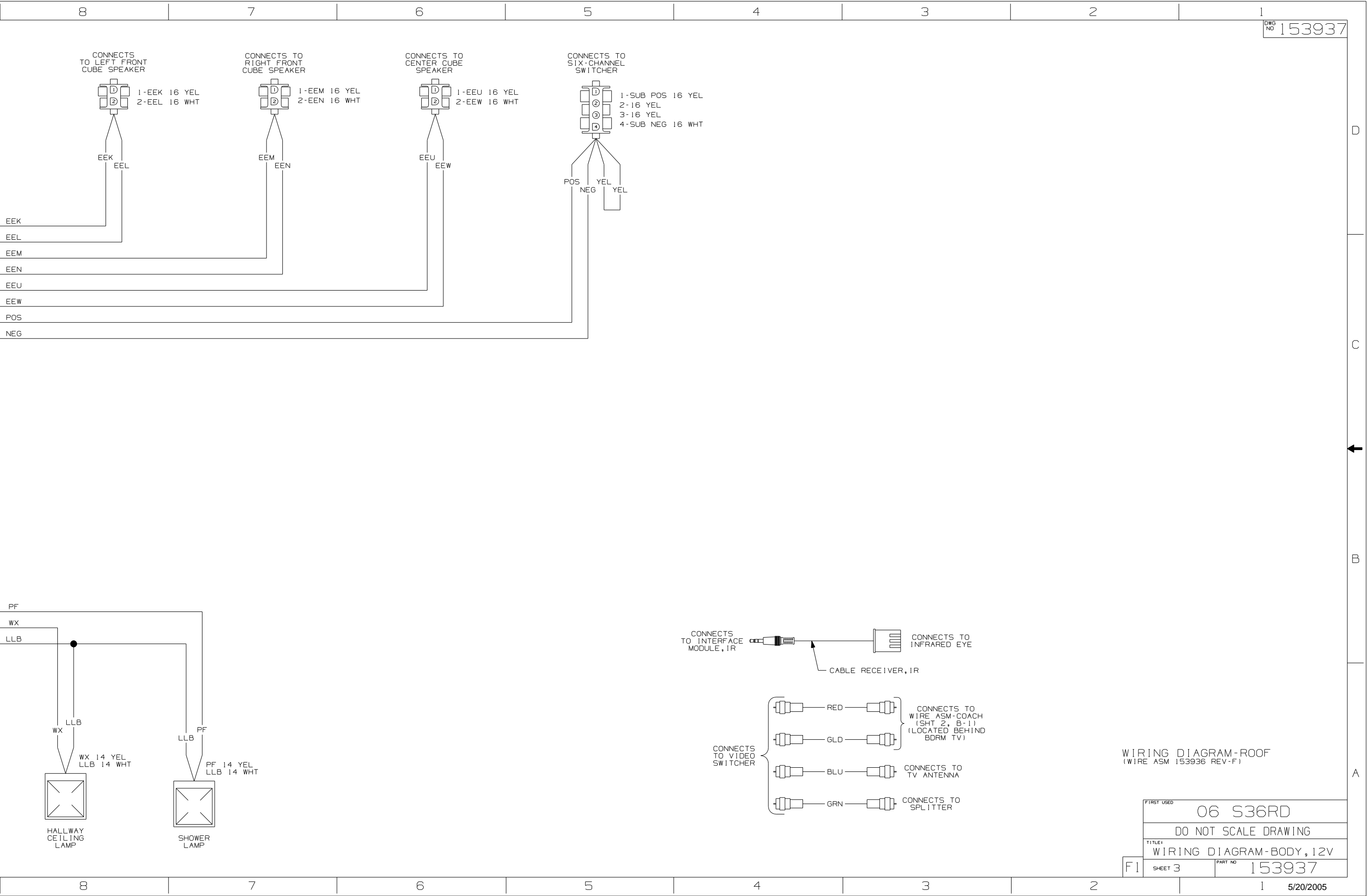

WIRING DIAGRAM-ROOF
(WIRE ASM 153936 REV-F)

FIRST USED	06 S36RD	
TITLE	DO NOT SCALE DRAWING	
	WIRING DIAGRAM-BODY, 12V	
F1	SHEET 3	PART NO 153937

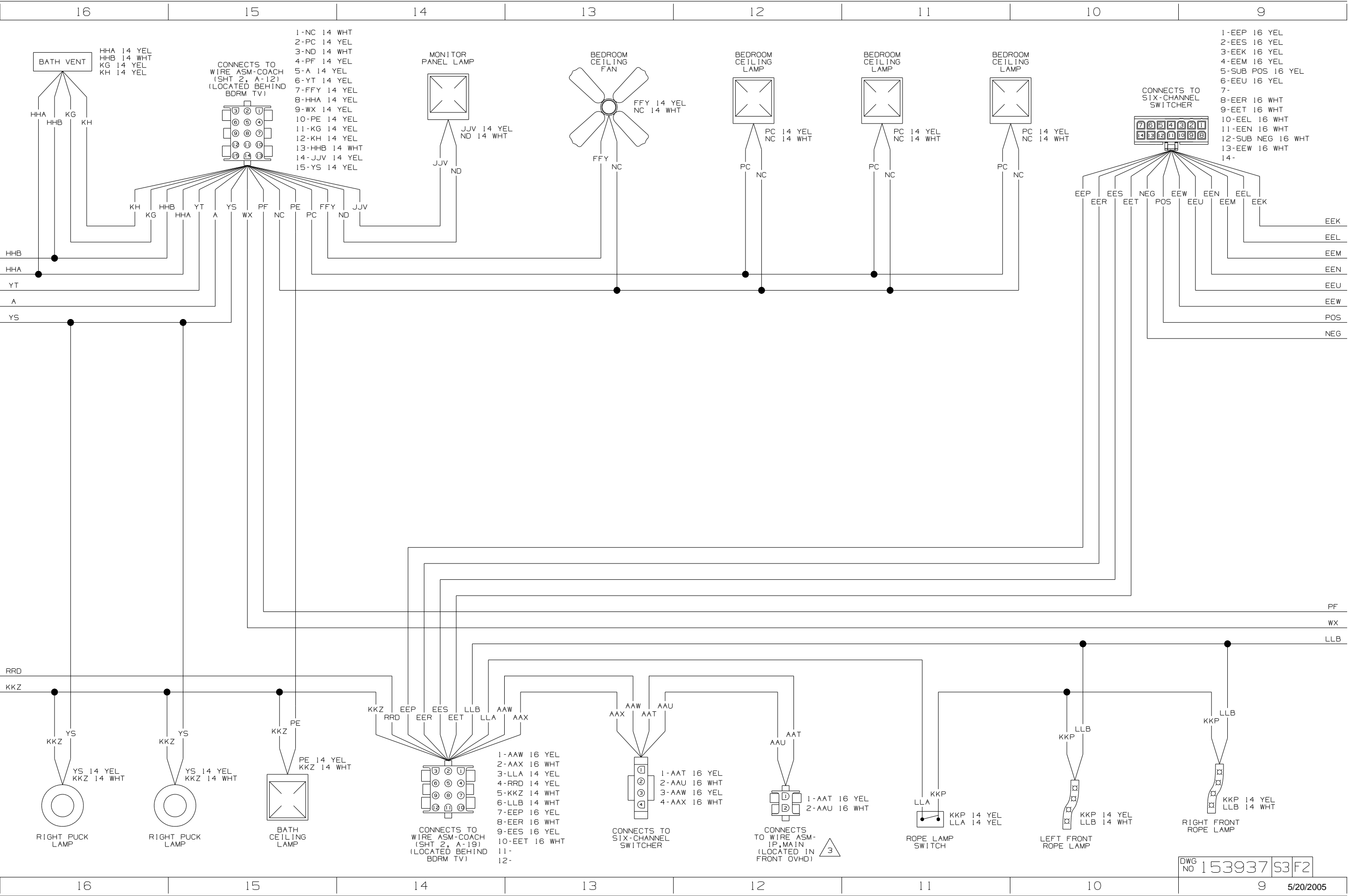

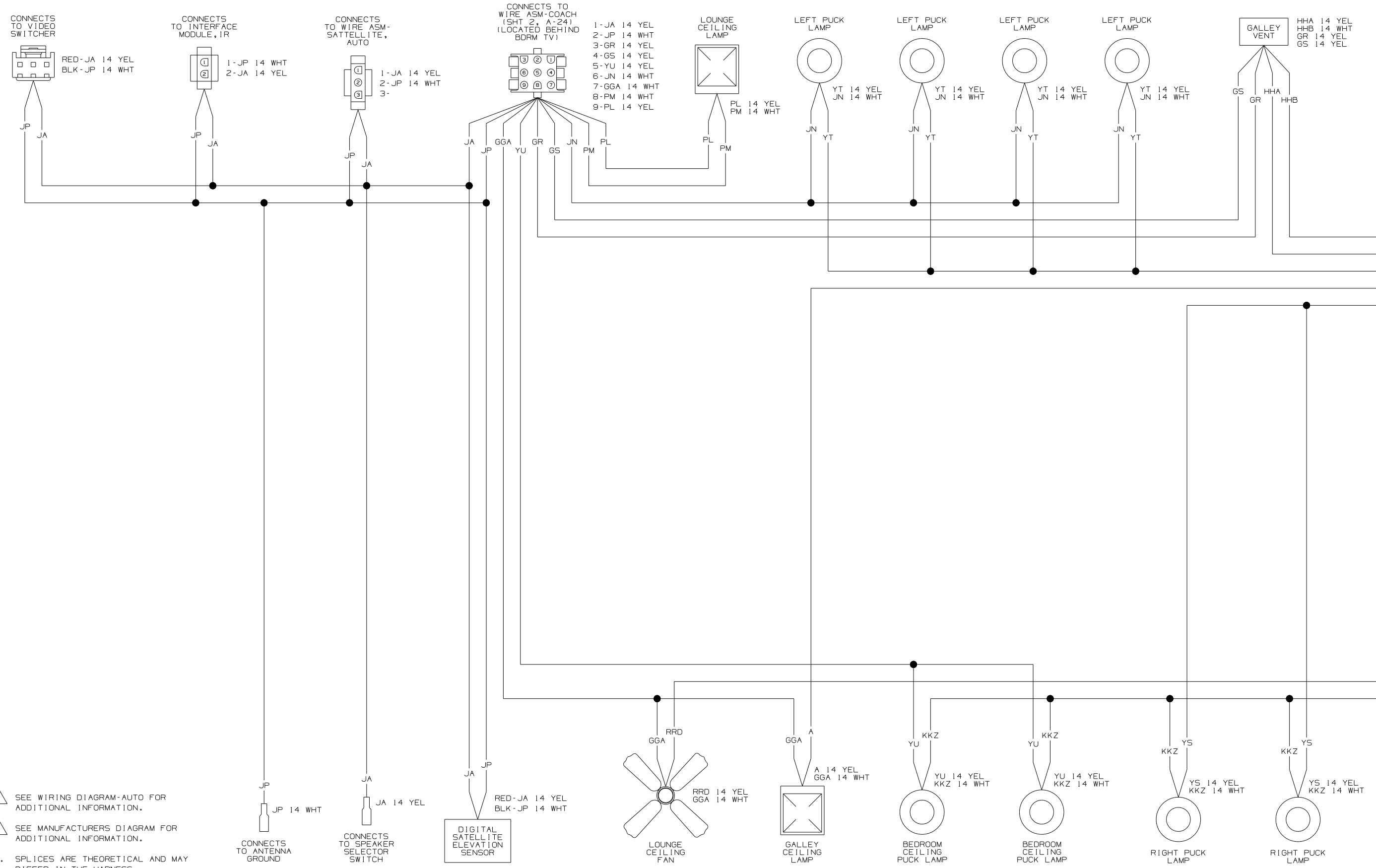

- CONNECTS TO WIRE ASM-COACH (SHT 2, A-24) (LOCATED BEHIND BDRM TV)
- 1-JA 14 YEL
 - 2-JP 14 WHT
 - 3-GR 14 YEL
 - 4-GS 14 YEL
 - 5-YU 14 YEL
 - 6-JN 14 WHT
 - 7-GGA 14 WHT
 - 8-PM 14 WHT
 - 9-PL 14 YEL

- GALLEY VENT
- HHA 14 YEL
 - HHB 14 WHT
 - GR 14 YEL
 - GS 14 YEL

3 SEE WIRING DIAGRAM-AUTO FOR ADDITIONAL INFORMATION.

2 SEE MANUFACTURERS DIAGRAM FOR ADDITIONAL INFORMATION.

1. SPLICES ARE THEORETICAL AND MAY DIFFER IN THE HARNESS.

NOTES:

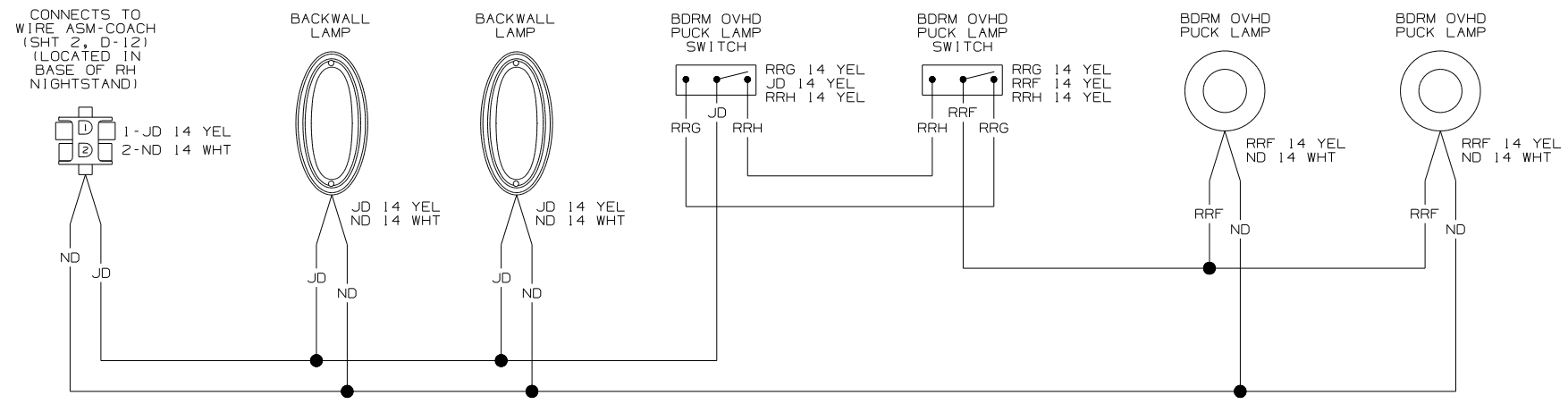

WIRING DIAGRAM-BACKWALL
(WIRE ASM 154033 REV-A)

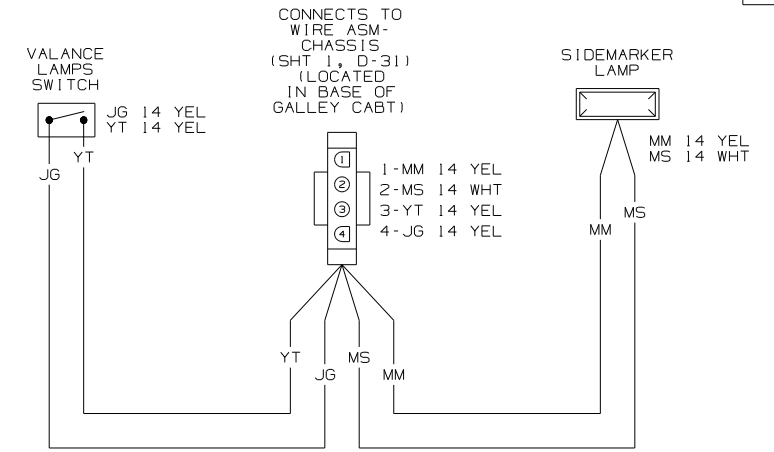

WIRING DIAGRAM-SLIDEOUT, LH, FRT
(WIRE ASM 145647 REV-A)

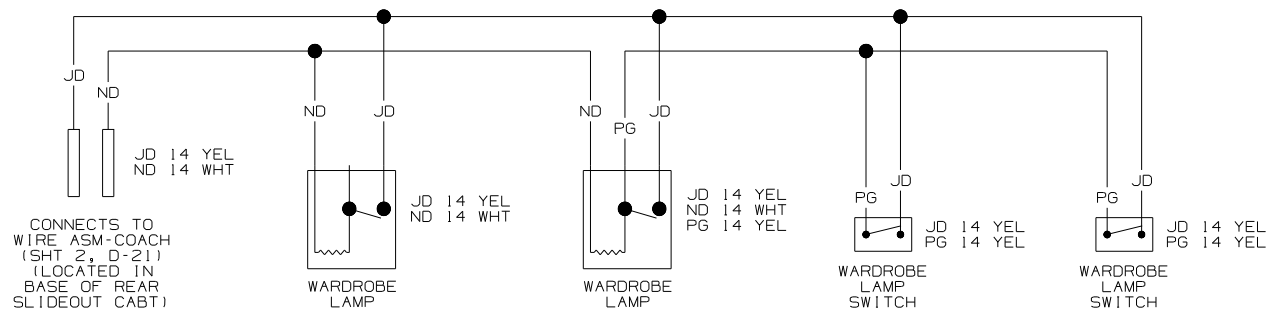

WIRING DIAGRAM-SLIDEOUT, REAR
(WIRE ASM 137456 REV-E)

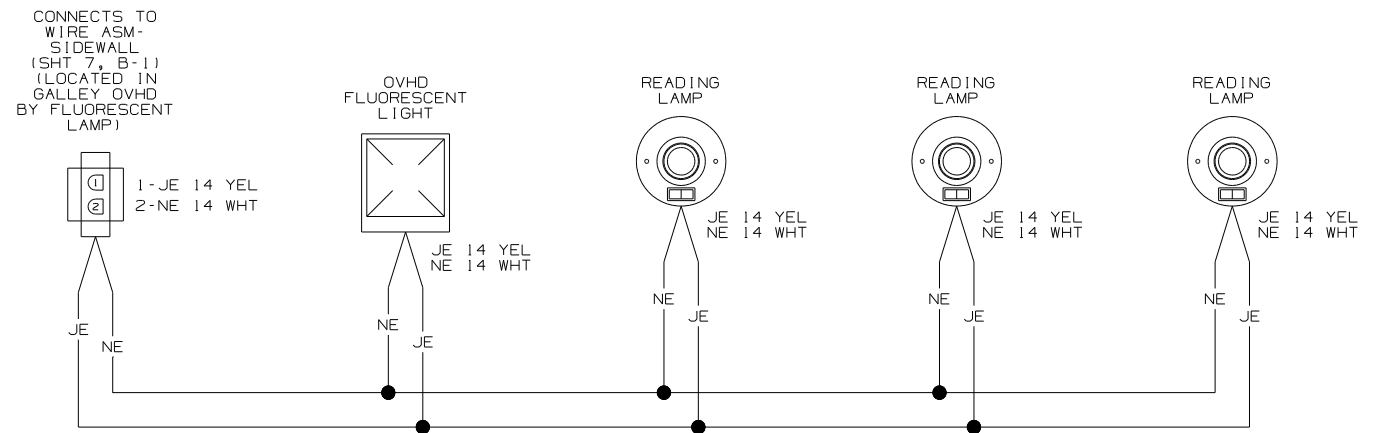

WIRING DIAGRAM-SLIDEOUT, RH, RR
(WIRE ASM 150548 REV-B)

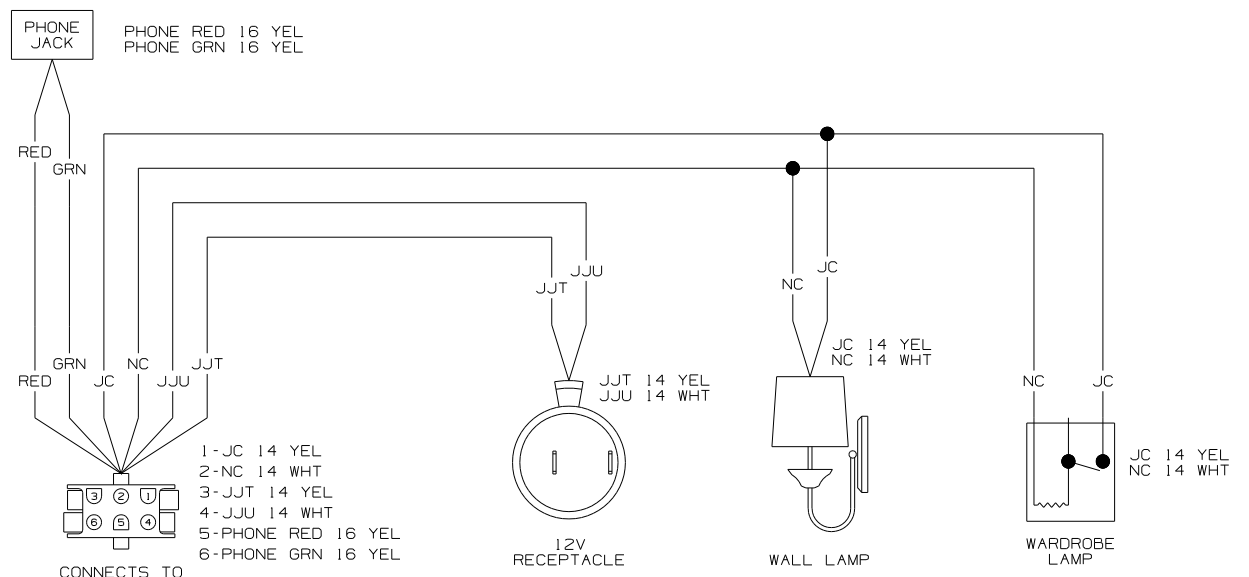

WIRING DIAGRAM-SLIDEOUT, RH, RR
(WIRE ASM 150548 REV-B)

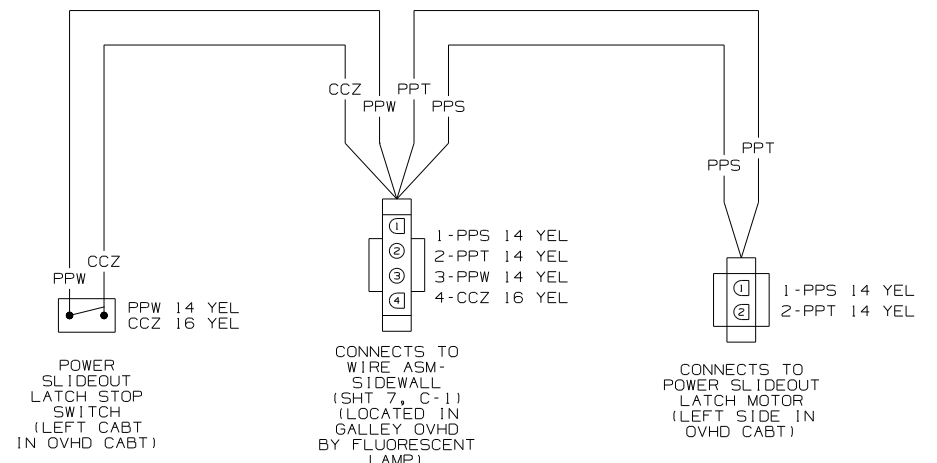

WIRING DIAGRAM-OVHD
(WIRE ASM 153959 REV-B)

- NOTES:
- 3 SEE WIRING DIAGRAM-AUTO FOR ADDITIONAL INFORMATION.
 - 2 SEE MANUFACTURERS DIAGRAM FOR ADDITIONAL INFORMATION.
 - 1. SPLICES ARE THEORETICAL AND MAY DIFFER IN THE HARNESS.

FIRST USED	06 S36RD
TITLE	DO NOT SCALE DRAWING
TITLE	WIRING DIAGRAM-BODY, 12V
SHEET 4	PART NO 153937

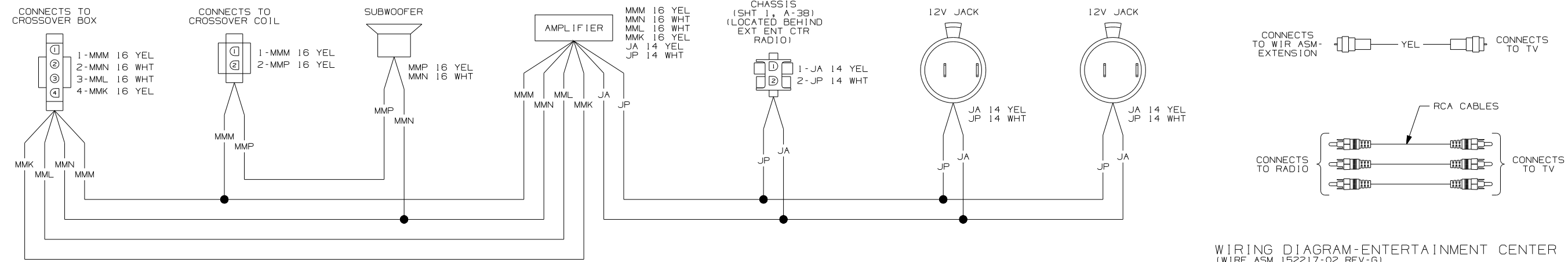

WIRING DIAGRAM-ENTERTAINMENT CENTER (WIRE ASM 152217-02 REV-G)

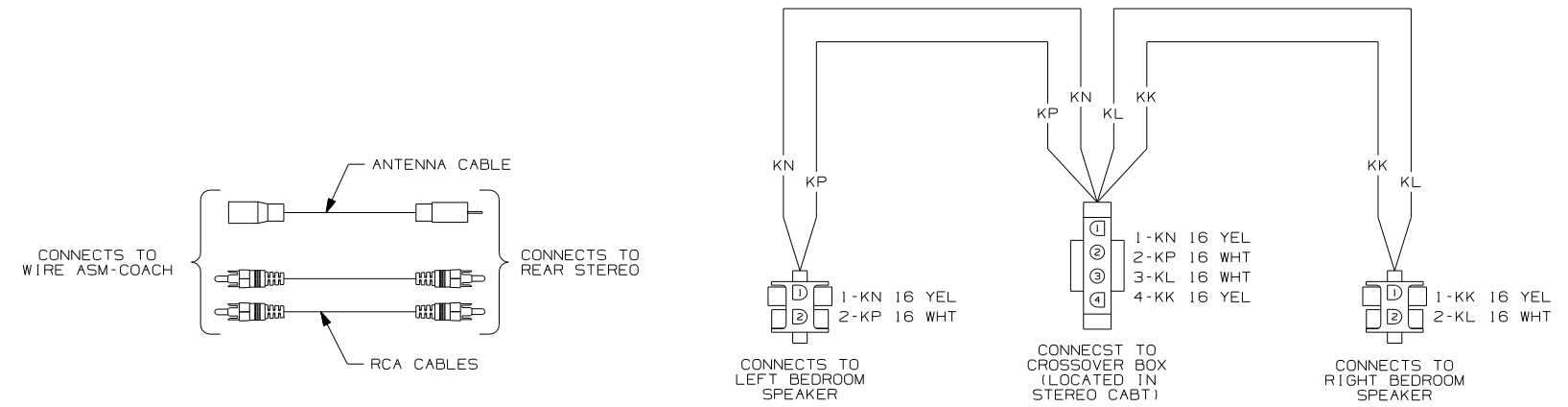
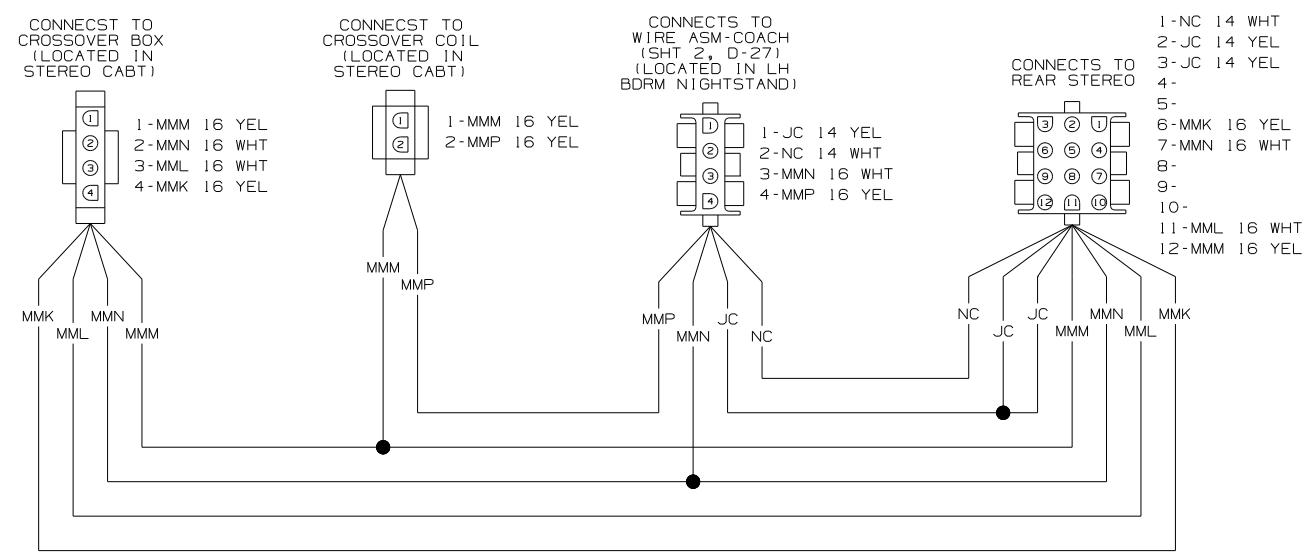
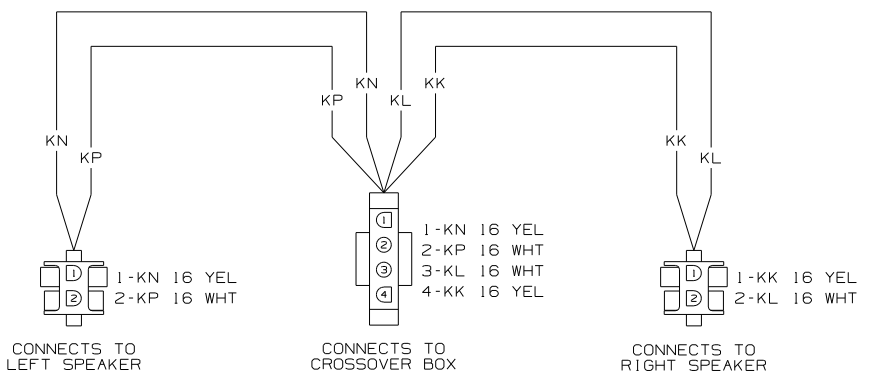

WIRING DIAGRAM-REAR STEREO (WIRE ASM 150563 REV-C)

3 SEE WIRING DIAGRAM-AUTO FOR ADDITIONAL INFORMATION.
 2 SEE MANUFACTURERS DIAGRAM FOR ADDITIONAL INFORMATION.
 1. SPLICES ARE THEORETICAL AND MAY DIFFER IN THE HARNESS.

FIRST USED	06 S36RD
TITLE	DO NOT SCALE DRAWING
TITLE	WIRING DIAGRAM-BODY, 12V
SHEET 5	PART NO 153937

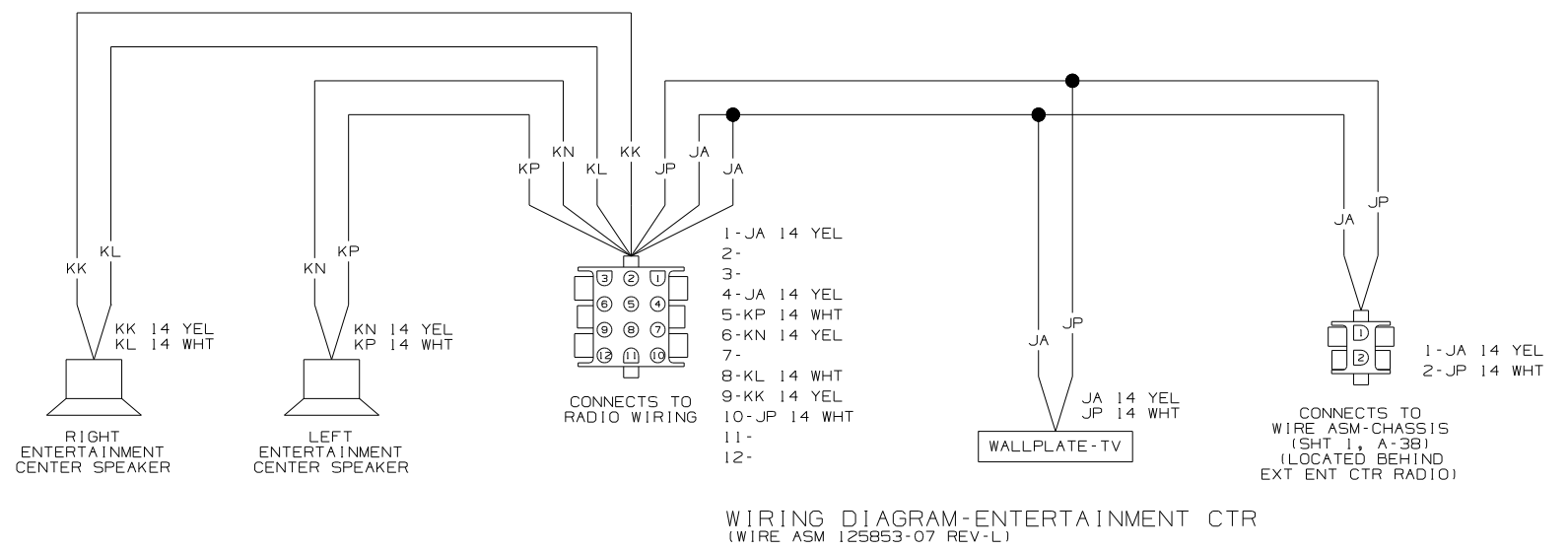
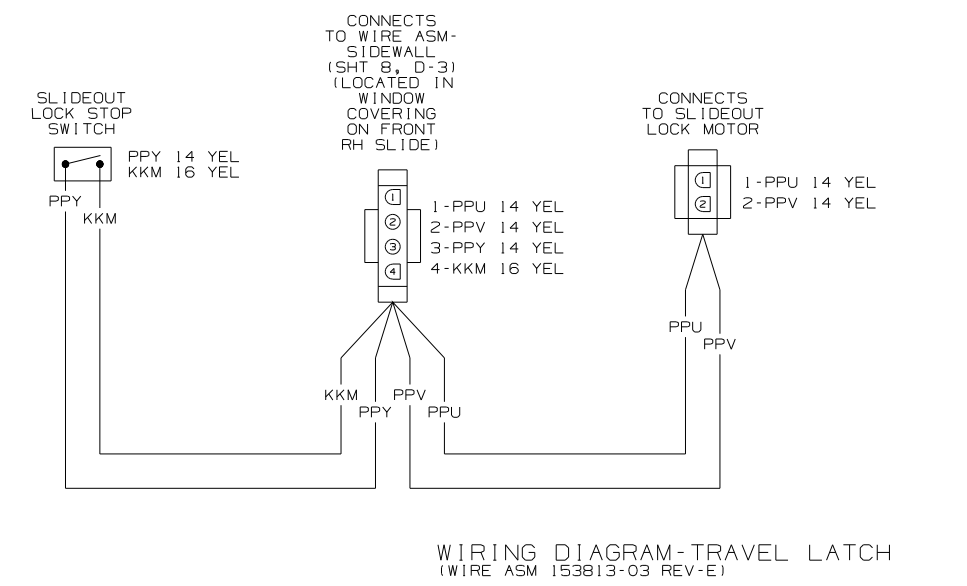
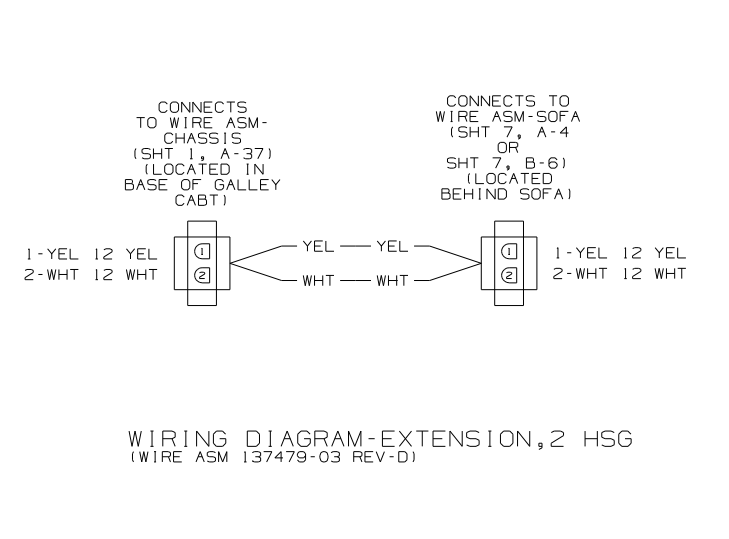
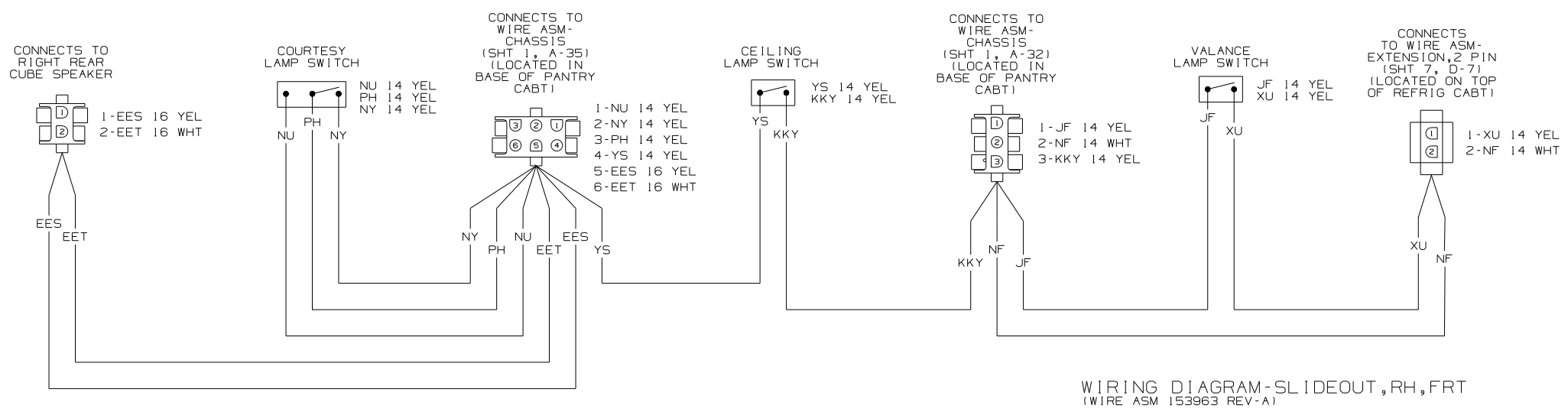

3 SEE WIRING DIAGRAM-AUTO FOR ADDITIONAL INFORMATION.

2 SEE MANUFACTURERS DIAGRAM FOR ADDITIONAL INFORMATION.

1. SPLICES ARE THEORETICAL AND MAY DIFFER IN THE HARNESS.

NOTES:

FIRST USED	06 S36RD
TITLE	DO NOT SCALE DRAWING
TITLE	WIRING DIAGRAM-BODY, 12V
SHEET 6	PART NO 153937

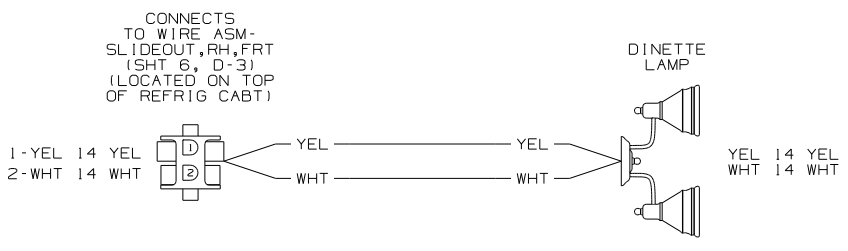

WIRING DIAGRAM-EXTENSION, 2 PIN
(WIRE ASM 149130 REV-B)

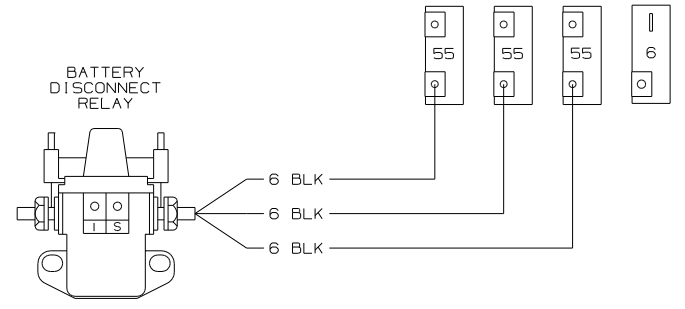

WIRING DIAGRAM-CHASSIS BKR FEED
(CABLE ASM 103843-06 REV-J)

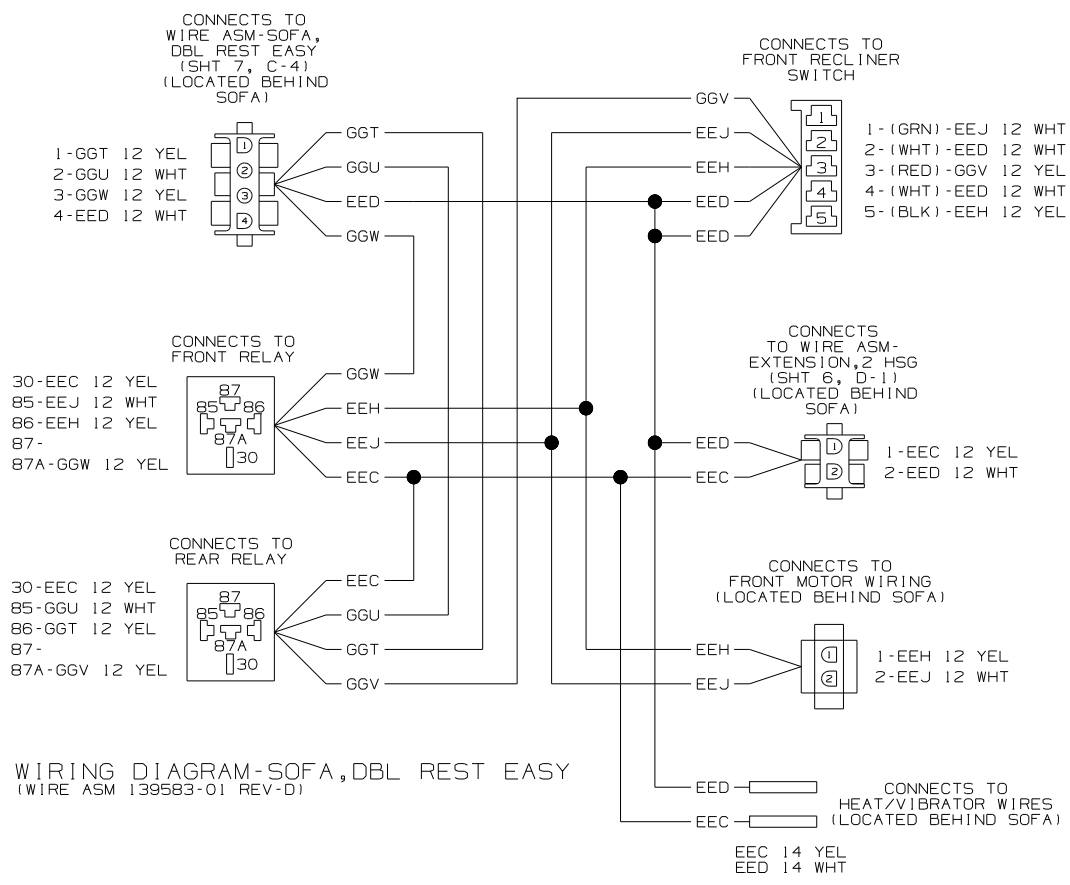
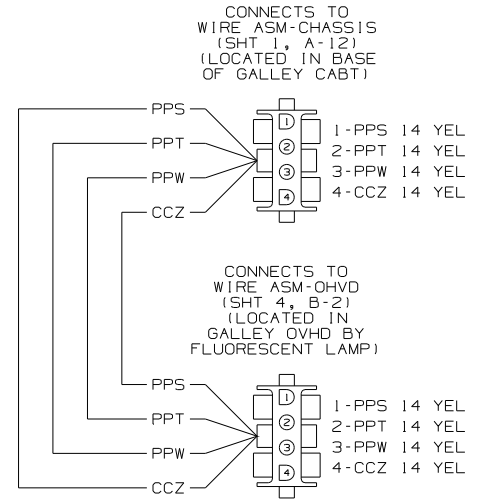

WIRING DIAGRAM-SOFA, DBL REST EASY
(WIRE ASM 139583-01 REV-D)

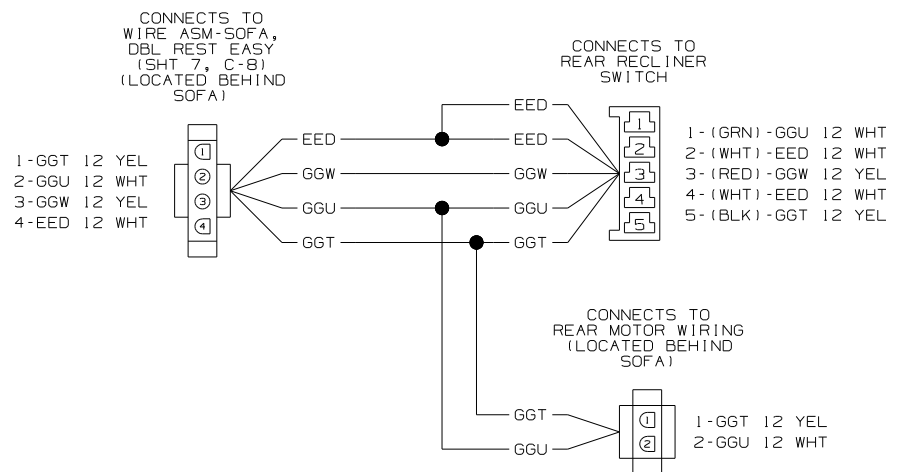

WIRING DIAGRAM-SOFA, DBL REST EASY
(WIRE ASM 139583-02 REV-D)

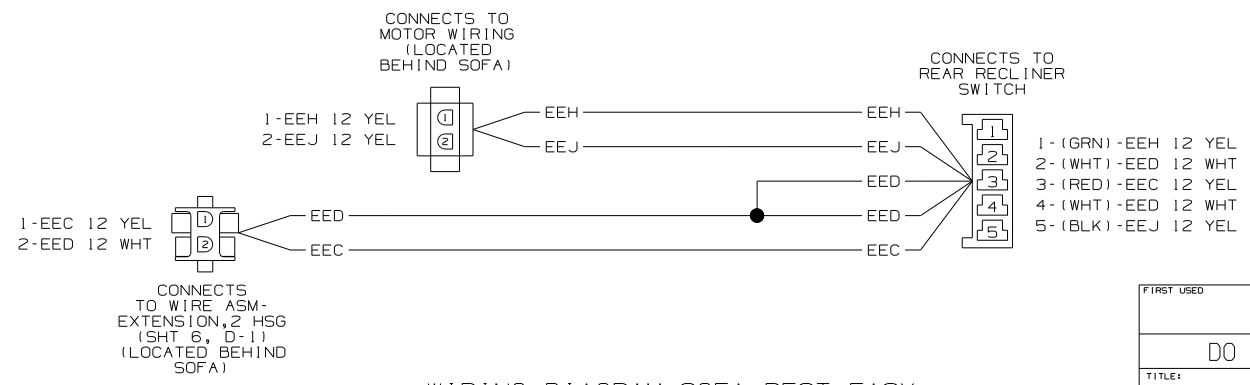

WIRING DIAGRAM-SOFA, REST EASY
(WIRE ASM 136028-01 REV-A)

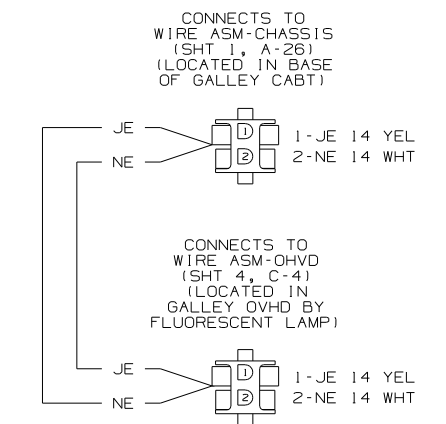

WIRING DIAGRAM-SIDEWALL
(WIRE ASM 153958 REV-B)

- NOTES:
- 3 SEE WIRING DIAGRAM-AUTO FOR ADDITIONAL INFORMATION.
 - 2 SEE MANUFACTURERS DIAGRAM FOR ADDITIONAL INFORMATION.
 - 1. SPLICES ARE THEORETICAL AND MAY DIFFER IN THE HARNESS.

FIRST USED	06 S36RD
TITLE	DO NOT SCALE DRAWING
TITLE	WIRING DIAGRAM-BODY, 12V
SHEET 7	PART NO 153937

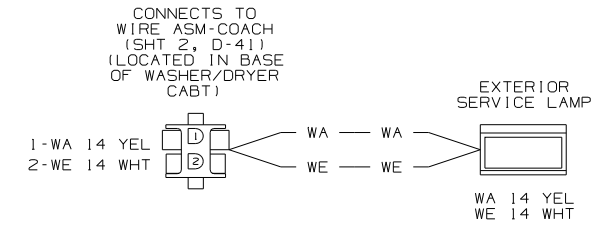
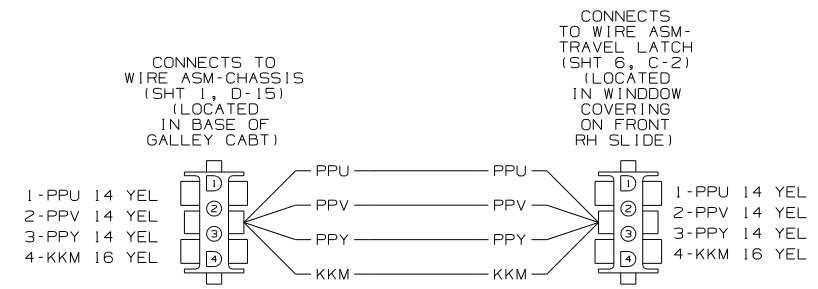
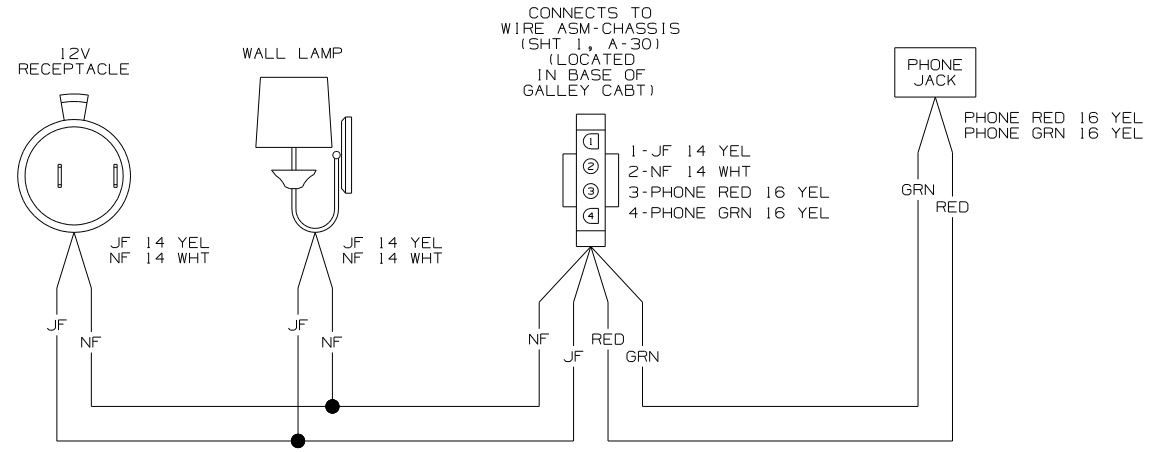

WIRING DIAGRAM-SIDEWALL (WIRE ASM 153950-01 REV-F)

WIRING DIAGRAM-SIDEWALL (WIRE ASM 77093-15 REV-AG)

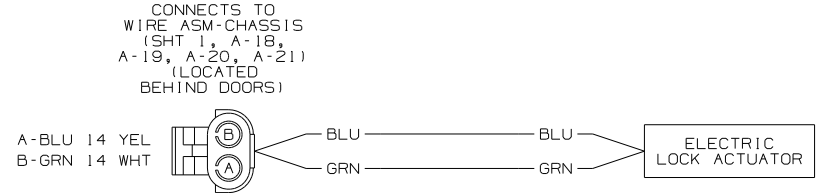
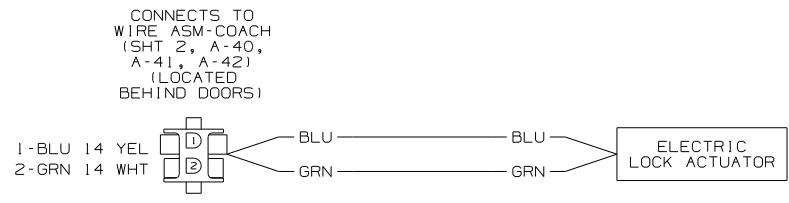
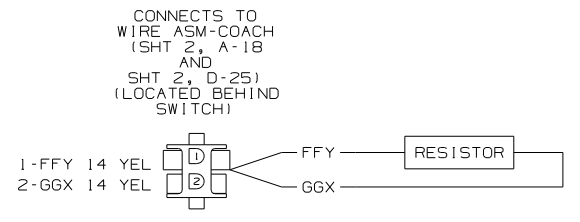

WIRING DIAGRAM-RESISTOR, FAN (WIRE ASM 140195 REV-A)

WIRING DIAGRAM-LOCKS, COMPT DOORS (WIRE ASM 135834-02 REV-J AND WIRE ASM 135834-05 REV-J)

WIRING DIAGRAM-LOCKS, COMPT DOORS (WIRE ASM 135834-03 REV-J)

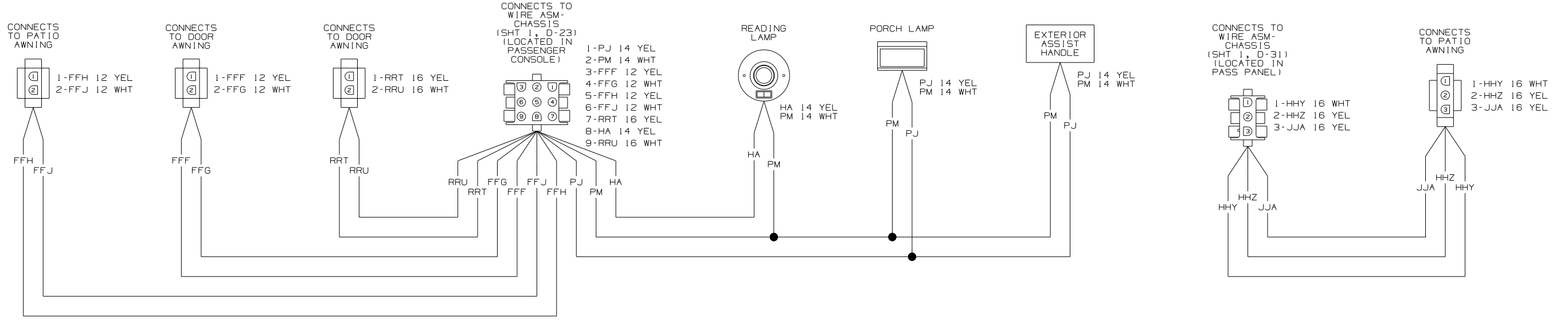

WIRING DIAGRAM-SIDEWALL (WIRE ASM 153530 REV-C)

- 3 SEE WIRING DIAGRAM-AUTO FOR ADDITIONAL INFORMATION.
- 2 SEE MANUFACTURERS DIAGRAM FOR ADDITIONAL INFORMATION.
1. SPLICES ARE THEORETICAL AND MAY DIFFER IN THE HARNESS.

NOTES:

FIRST USED	06 S36RD
TITLE	DO NOT SCALE DRAWING
TITLE	WIRING DIAGRAM-BODY, 12V
SHEET 8	PART NO 153937