



DANGER

Danger of electrical shock, burns or death. Always remove all power sources before attempting any repair, service or diagnostic work. Power can be present from shore power, generator, inverter or battery. All power sources must be disabled and secured before performing any service.



CAUTION

If you lack the skills, tools or equipment to perform diagnostic or repair work leave such work to an authorized Winnebago Industries dealer or other qualified shop.

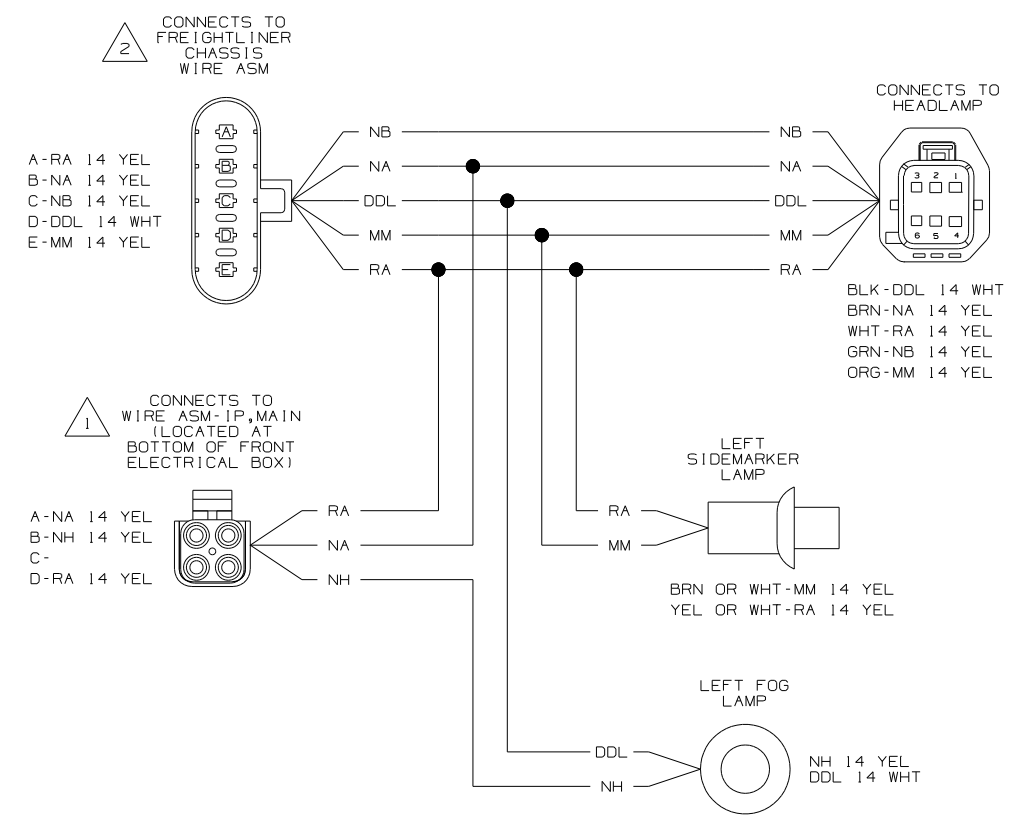

WIRING DIAGRAM-HEADLAMP
(WIRE ASM 146086-05 REV-K)
(WINNEBAGO)

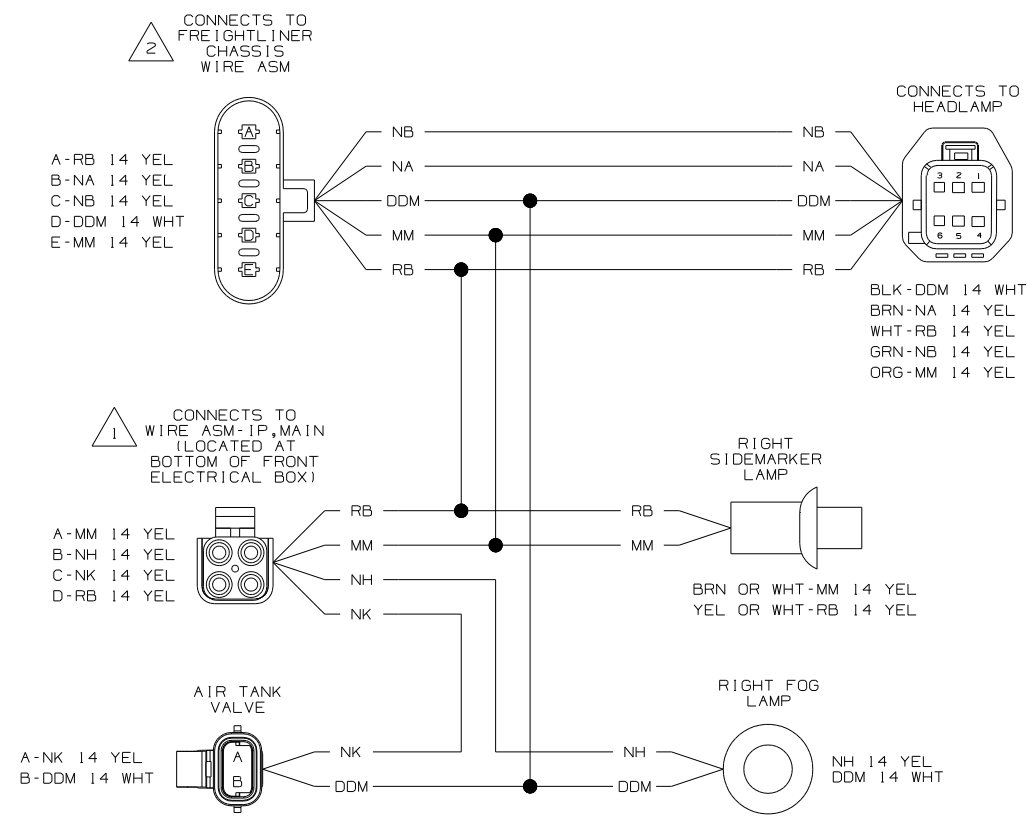

WIRING DIAGRAM-HEADLAMP
(WIRE ASM 146086-06 REV-K)
(WINNEBAGO)

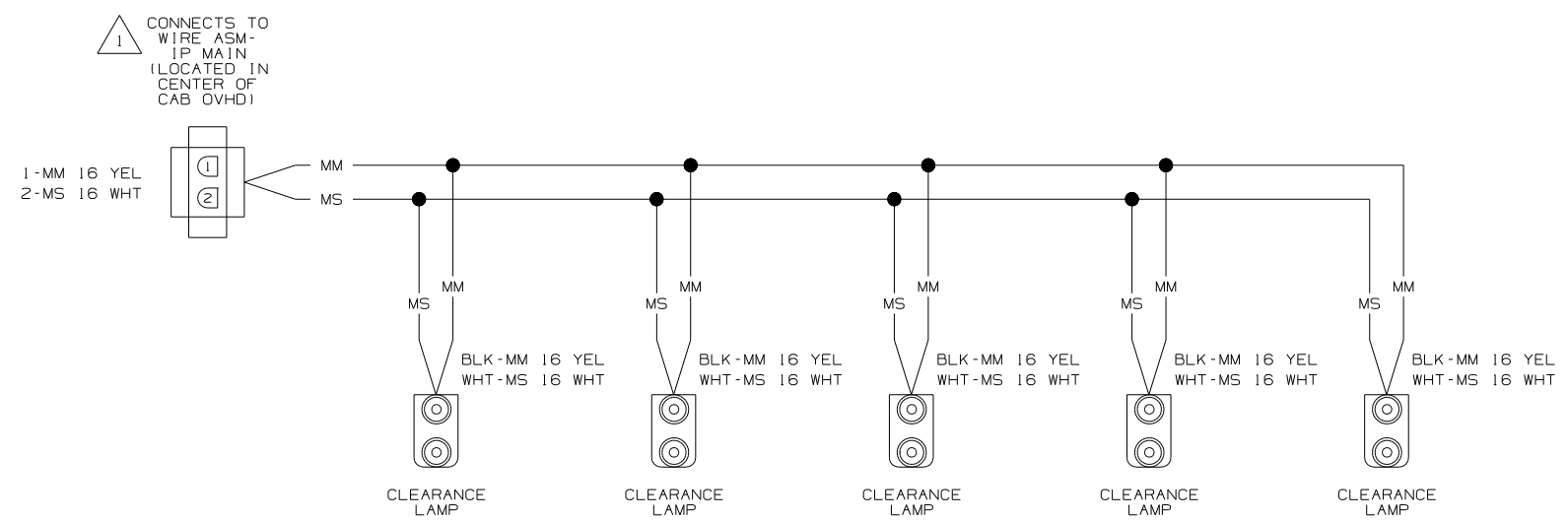

WIRING DIAGRAM-CLEARANCE LAMPS
(WIRE ASM 126486-04 REV-F)

NOTES:

2 SEE MANUFACTURER'S DIAGRAM FOR ADDITIONAL INFORMATION.

1 SEE WIRING DIAGRAM AUTO FOR ADDITIONAL INFORMATION.

WINNEBAGO		COPYRIGHT 2004 WINNEBAGO INDUSTRIES, INC.	
DFTR	ORIG. DATE	ALL DIMENSIONS ARE IN MILLIMETERS	
CHKR		FIRST USED	
P.E.		06 S-SERIES	
M.E.		UNSPECIFIED TOLERANCES ARE:	
DSNR		MATERIAL:	
		WHOLE DIM (X)	:
		ONE-PLACE (X.X)	:
		TWO-PLACE (X.XX)	:
		ANGLE	:
		THIRD ANGLE PROJECTION	
DO NOT SCALE DRAWING			
TITLE: WIRING DIAGRAM-AUTO LAMPS			
SHEET 1 OF 3	PART NO	152120	
REF:	1 5/18/2005		

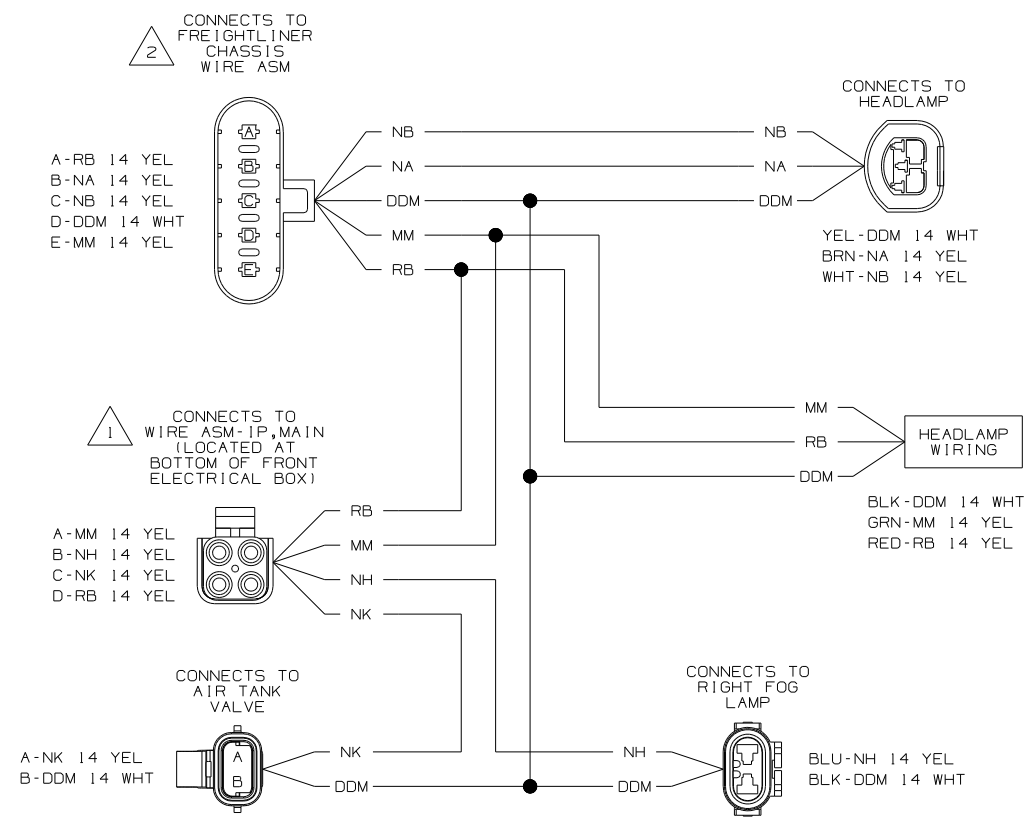
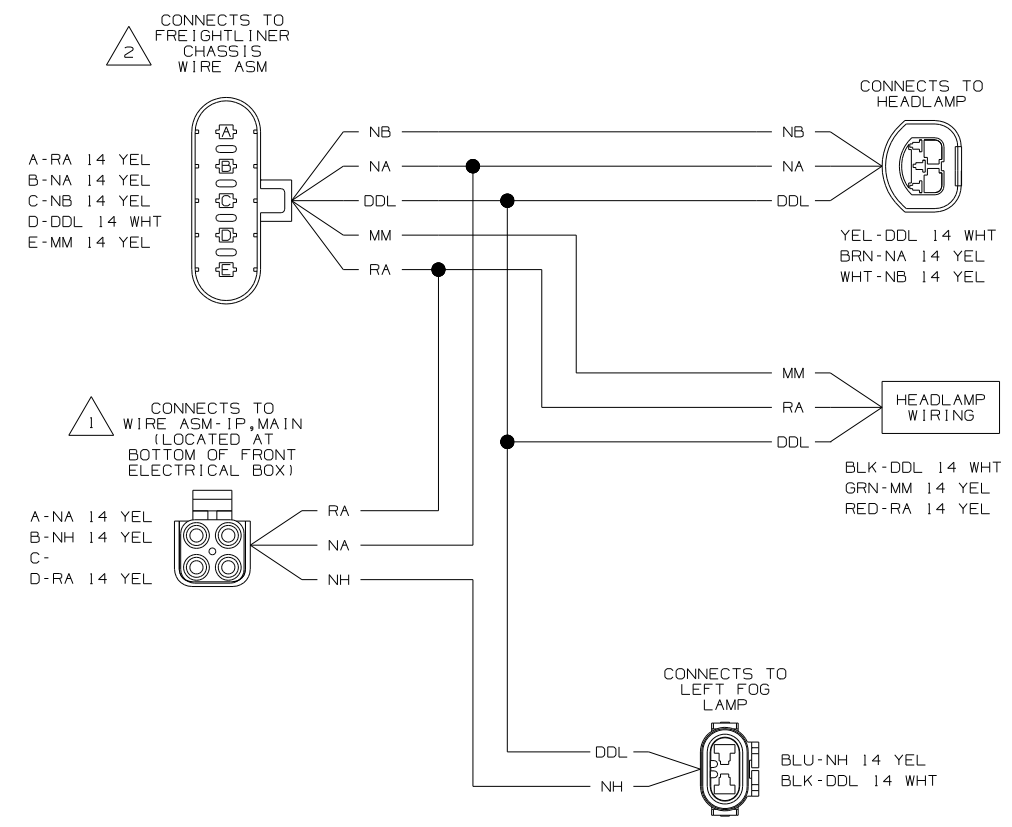

NOTES:

2 SEE MANUFACTURER'S DIAGRAM FOR ADDITIONAL INFORMATION.

1 SEE WIRING DIAGRAM AUTO FOR ADDITIONAL INFORMATION.

FIRST USED	06 S-SERIES
TITLE	DO NOT SCALE DRAWING
SHEET 2	PART NO 152120

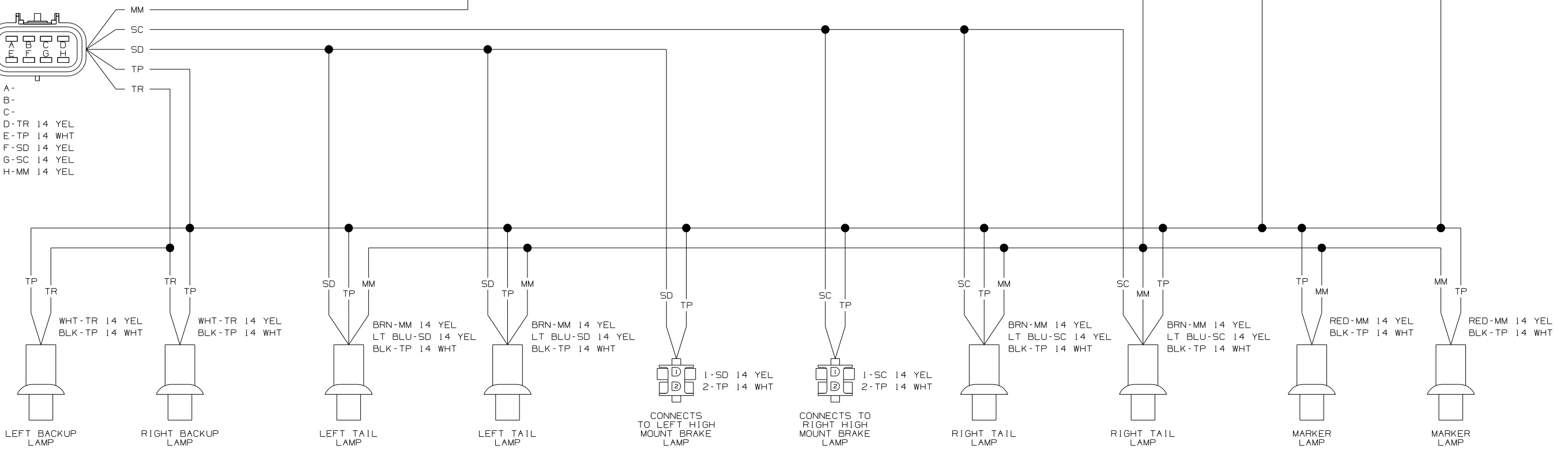
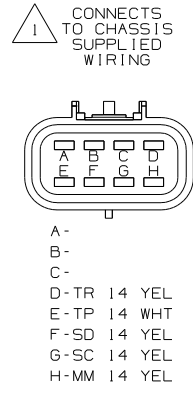
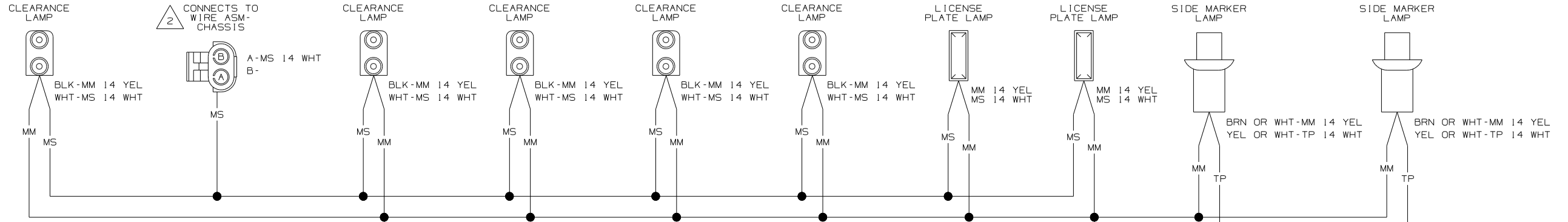

WIRING DIAGRAM-BACKWALL, FL (WIRE ASM 146221-06 REV-K)

NOTES:

2 SEE WIRING DIAGRAM-BODY, 12V FOR ADDITIONAL INFORMATION.

1 SEE MANUFACTURER'S DIAGRAM FOR ADDITIONAL INFORMATION.

FIRST USED	06 S-SERIES
TITLE	DO NOT SCALE DRAWING
WIRING DIAGRAM-AUTO LAMPS	
SHEET 3	PART NO 152120