



**DANGER**

**Danger of electrical shock, burns or death.** Always remove all power sources before attempting any repair, service or diagnostic work. Power can be present from shore power, generator, inverter or battery. All power sources must be disabled and secured before performing any service.



**CAUTION**

If you lack the skills, tools or equipment to perform diagnostic or repair work leave such work to an authorized Winnebago Industries dealer or other qualified shop.

DRAWING NO.	FEATURE
153550-01	-----
153550-12	(1B1) (78J)
153550-14	(1B1) (78J) (13X)
153550-16	(265) (78J)
153550-18	(265) (78J) (13X)

RELEASE	REV/DATE	DWG NO
A		153550
REV ZONE	REVISION RECORD	DATE
		DFTR-0R1G

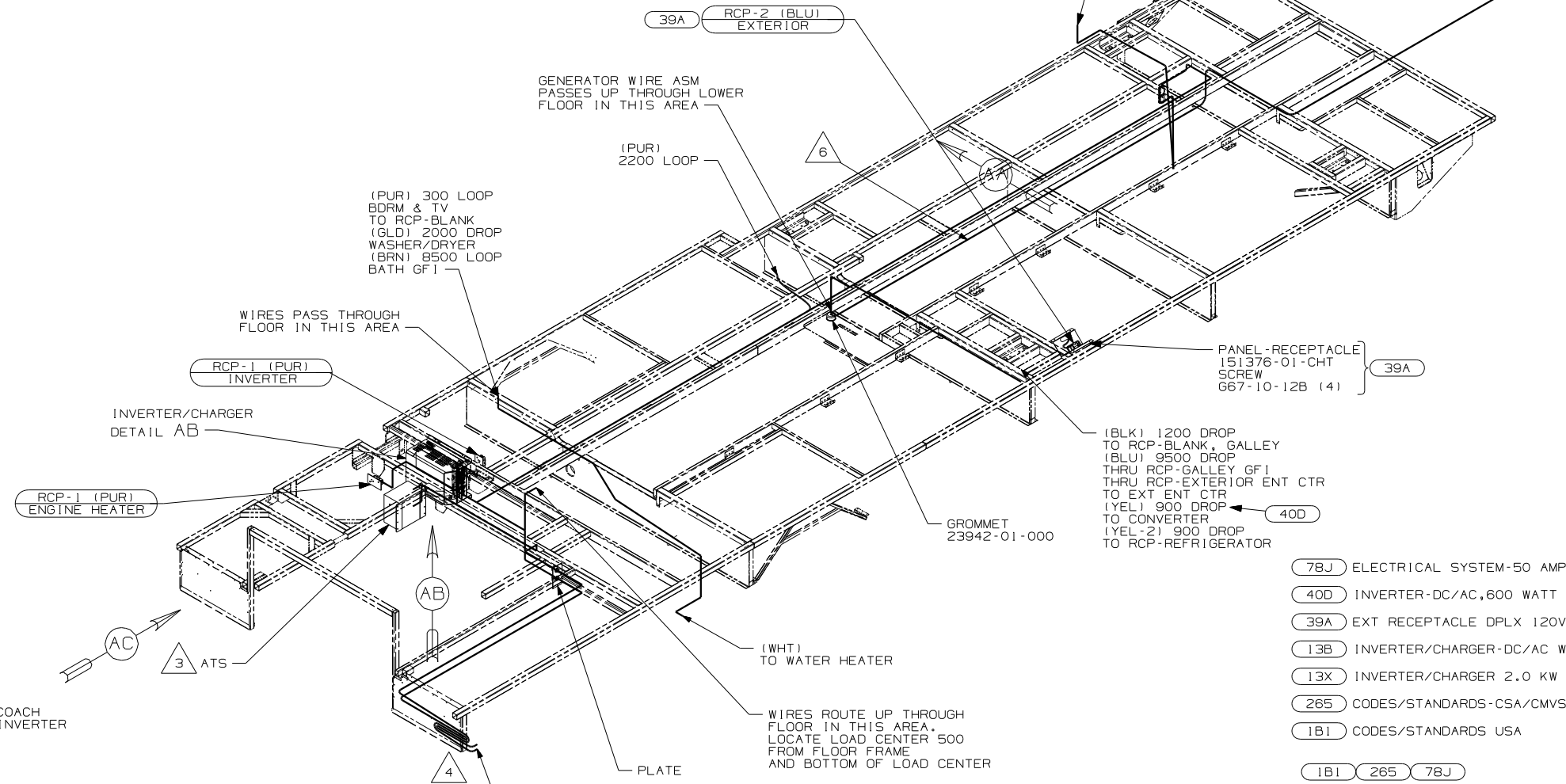
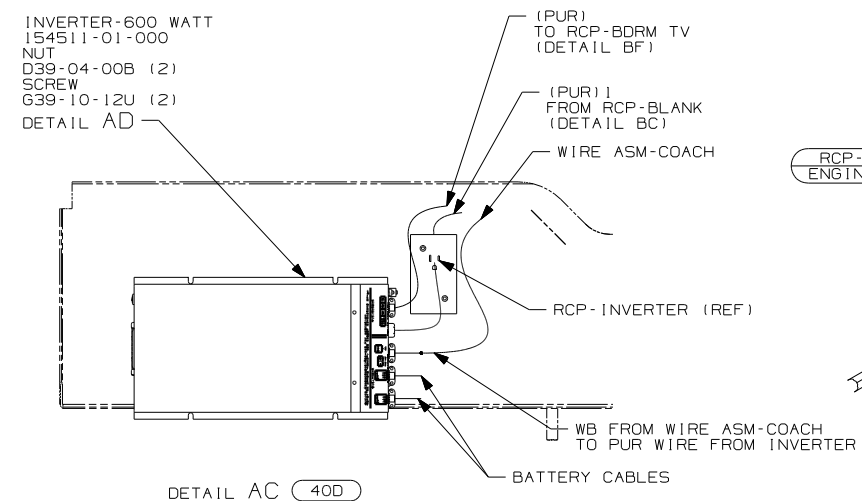
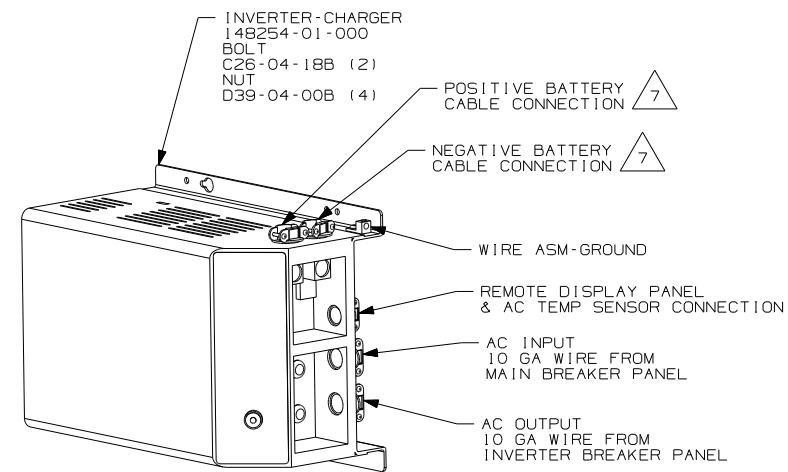
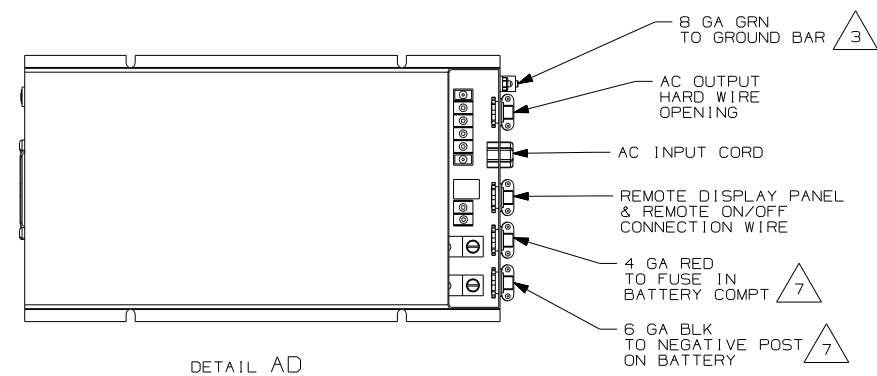

- NOTES:
- 7 SEE WIRING INSTL-CHASSIS FOR ADDITIONAL INFORMATION.
  - 6 ROUTED ALONG CHASSIS RAIL IN THIS AREA.
  - 5 SEE GENERATOR INSTALLATION FOR ADDITIONAL INFORMATION.
  - 4 SEE A/C INSTALLATION FOR ADDITIONAL INFORMATION.
  - 3 SEE LOAD CENTER/ATS ASM FOR ADDITIONAL INFORMATION.
  - 2. WIRE THAT REST ON WIRE TRAYS ARE TO BE TIED DOWN WITH WIRE TIE 8343-02-000.
  - 1. ALL WIRES TO BE SECURED WITH CLAMP 10495 OR 10497 OR WIRE TIE 8343 OR 108046 EVERY 600MM, USE SCREW G67-XX-XXX OR G56-XX-XXX AS APPROPRIATE FOR INTALLATION.

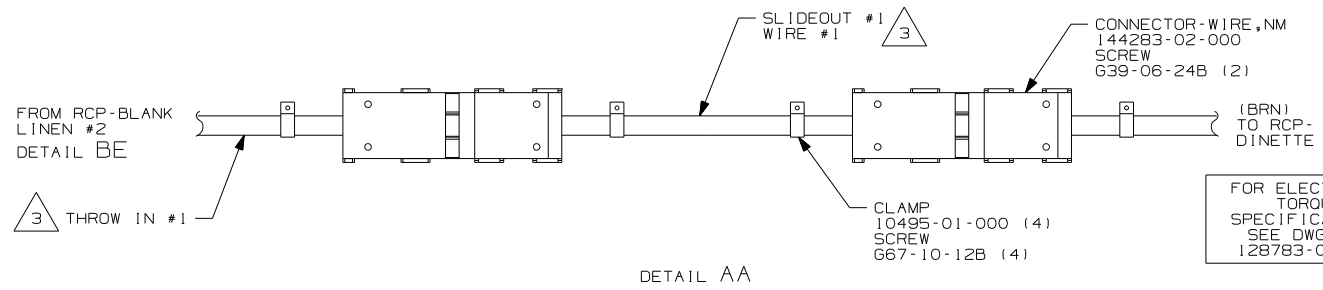

FOR ELECTRICAL TORQUE SPECIFICATIONS SEE DWG NO. 128783-01-000

(X-X) FOR ELECTRICAL CALLOUTS SEE DWG NO. 121339-01-000

- (78J) ELECTRICAL SYSTEM-50 AMP
- (40D) INVERTER-DC/AC,600 WATT
- (39A) EXT RECEPTACLE DPLX 120VAC
- (13B) INVERTER/CHARGER-DC/AC W/O
- (13X) INVERTER/CHARGER 2.0 KW
- (265) CODES/STANDARDS-CSA/CMVSS
- (1B1) CODES/STANDARDS USA

1B1 265 78J

**WINNEBAGO** COPYRIGHT 2004 WINNEBAGO INDUSTRIES, INC.

DFTR	ORIG. DATE
CHKR	ALL DIMENSIONS ARE IN MILLIMETERS
P.E.	
M.E.	FIRST USED
DSNR	06 P36G

UNSPECIFIED TOLERANCES ARE: MATERIAL:

WHOLE DIM (X) :  
ONE-PLACE (X.X) :  
TWO-PLACE (X.XX) :  
ANGLE :

THIRD ANGLE PROJECTION

DO NOT SCALE DRAWING

TITLE: WIRING INSTL-BODY, 110V

SHEET 1 OF 3 PART NO 153550

REF: 1 12/2005

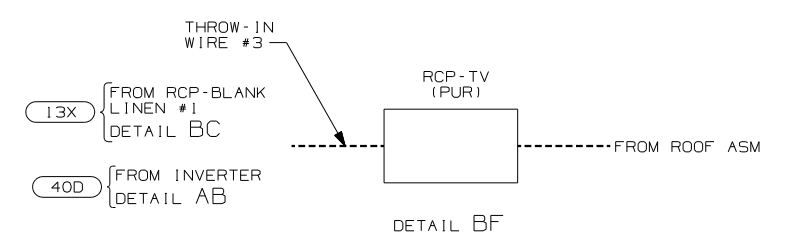
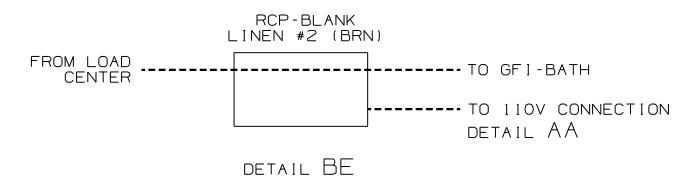
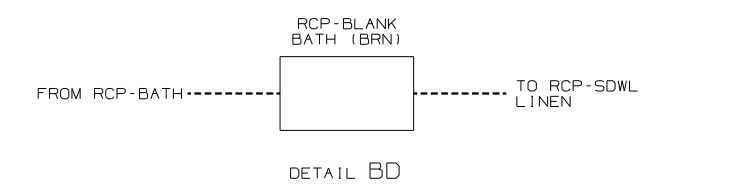
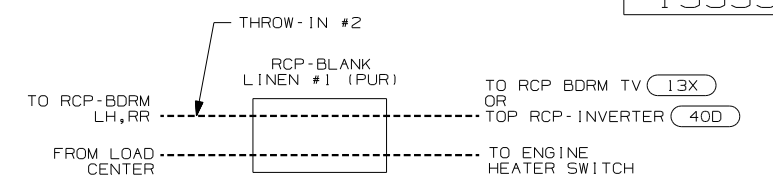
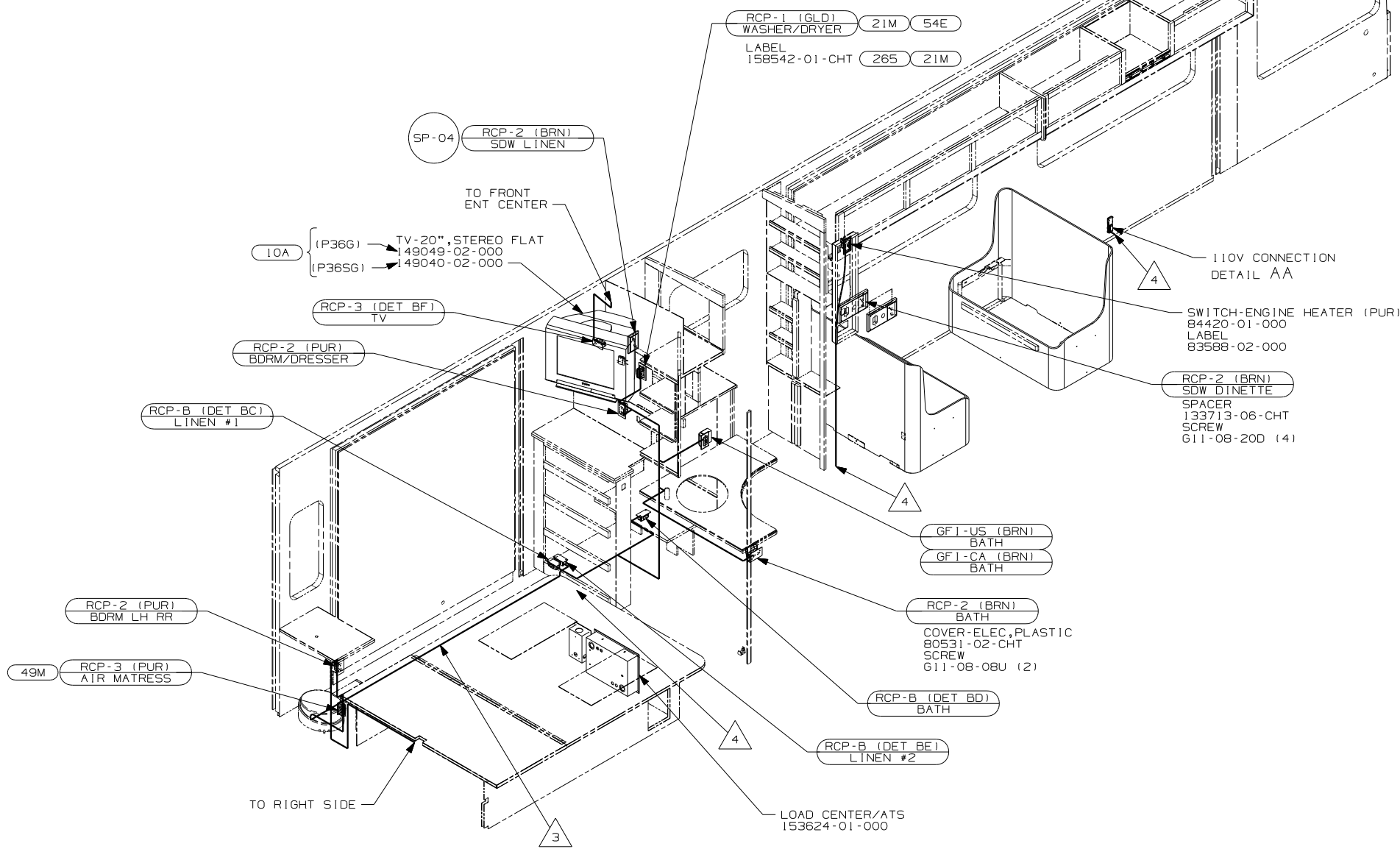

- (78J) ELECTRICAL SYSTEM-50 AMP
- (54E) WASHER/DRYER
- (49M) SLEEP NUMBER BED-QUEEN SIZE
- (40D) INVERTER-DC/AC,600 WATT
- (21M) WASHER/DRYER PREP
- (13X) INVERTER/CHARGER 2.0 KW
- (10A) TV (REAR) -20"COLOR, STEREO
- (265) CODES/STANDARDS-CSA/CMVSS
- (1B1) CODES/STANDARDS USA

- 4 WIRES ROUTE UP THRU FLOOR IN THIS AREA.
- 3 ROUTE WIRE IN FLOOR

2. ALL WIRES ARE TO BE CLAMPED WITH CLAMP 10497-05-000 WITHIN 200 FO OUTLET BOXES AND SPLICES. USE SCREW G67-10-12B
1. ALL WIRES TO BE SECURED WITH CLAMP 10495 OR 10497 OR WIRE TIE 8343 OR 108046 EVERY 600MM, USE SCREW G67-XX-XXX OR G56-XX-XXX AS APPROPRIATE FOR INTALLATION.

NOTES:

FOR ELECTRICAL TORQUE SPECIFICATIONS SEE DWG NO. 128783-01-000

FOR ELECTRICAL CALLOUTS SEE DWG NO. 121339-01-000

FIRST USED	06 P36G
TITLE	DO NOT SCALE DRAWING
TITLE	WIRING INSTL-BODY, 110V
SHEET 2	PART NO 153550

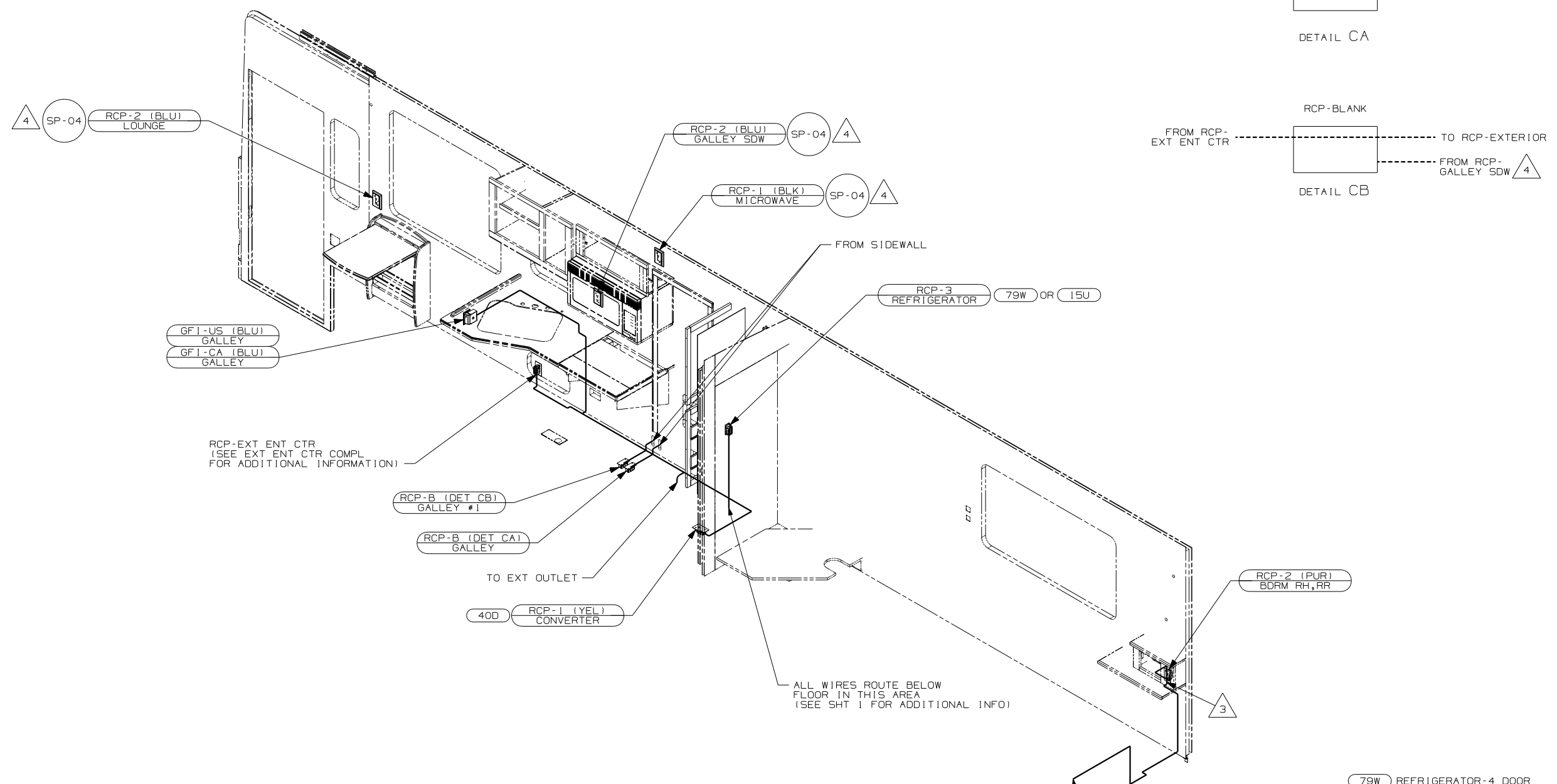

- 4 WIRE IN SIDEWALL  
 3 ROUTE WIRE IN SIDEWALL DURING INSTALLATION.  
 2. ALL WIRES ARE TO BE CLAMPED WITH CLAMP 10497-05-000. WITHIN 200 FO OUTLET BOXES AND SPLICES, USE SCREW G67-10-12B.  
 1. ALL WIRES TO BE SECURED WITH CLAMP 10495 OR 10497 OR WIRE TIE 8343 OR 108046 EVERY 600MM, USE SCREW G67-XX-XXX OR G56-XX-XXX AS APPROPRIATE FOR INTALLATION.

NOTES:

FOR ELECTRICAL TORQUE SPECIFICATIONS SEE DWG NO. 128783-01-000

FOR ELECTRICAL CALLOUTS SEE DWG NO. 121339-01-000

- 79W REFRIGERATOR-4 DOOR
- 40D INVERTER-DC/AC, 600 WATT
- 15U REFRIGERATOR/FRZR W/ICEMAKER
- 78J ELECTRICAL SYSTEM-50 AMP
- 12D ELECTRICAL SYSTEM 30 AMP
- 265 CODES/STANDARDS-CSA/CMVSS
- 1B1 CODES/STANDARDS USA

FIRST USED	
06 P36G	
DO NOT SCALE DRAWING	
TITLE: WIRING INSTL-BODY, 110V	
SHEET 3	PART NO 153550