



DANGER

Danger of electrical shock, burns or death. Always remove all power sources before attempting any repair, service or diagnostic work. Power can be present from shore power, generator, inverter or battery. All power sources must be disabled and secured before performing any service.



CAUTION

If you lack the skills, tools or equipment to perform diagnostic or repair work leave such work to an authorized Winnebago Industries dealer or other qualified shop.

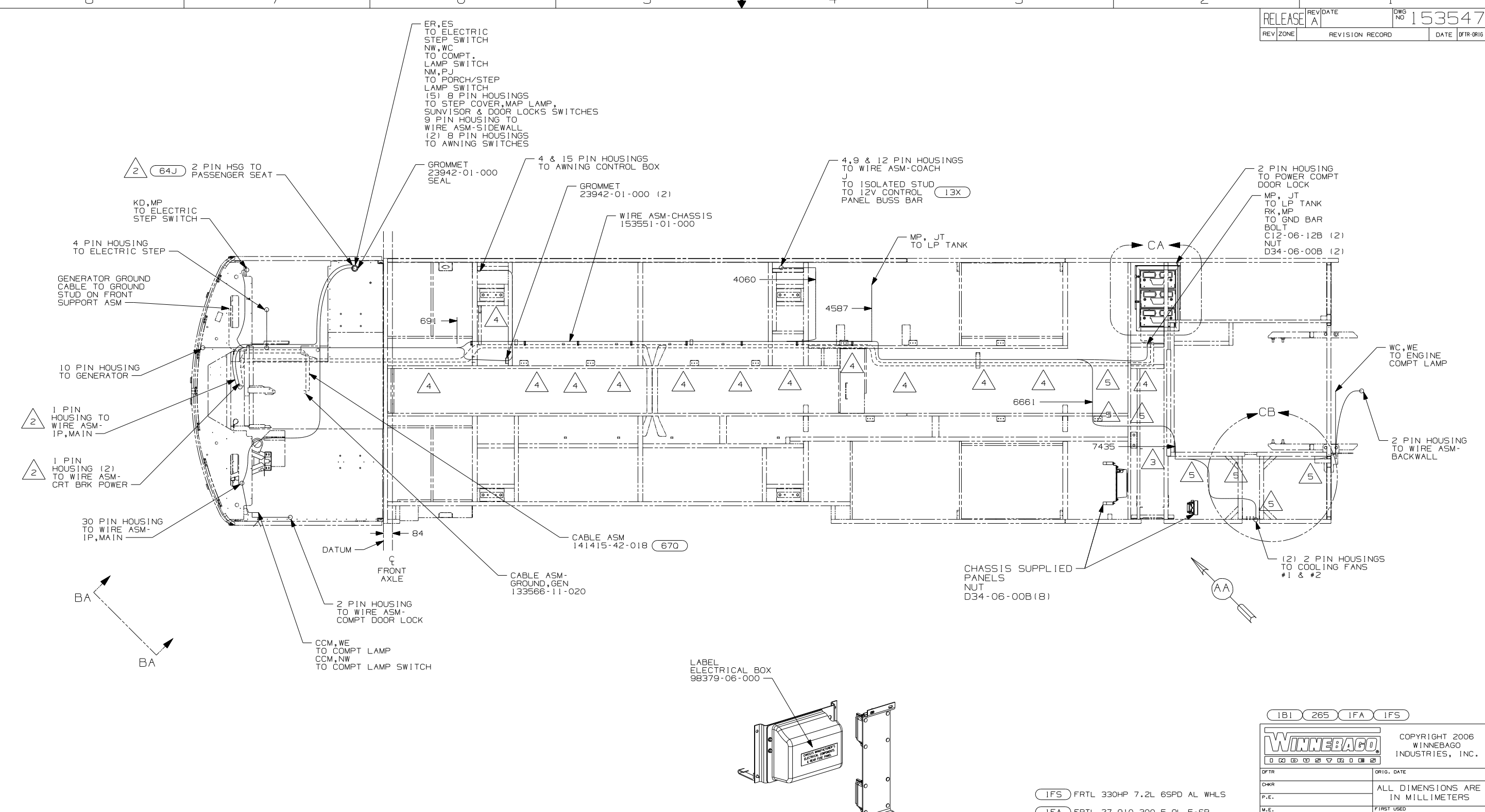

- 5 CLAMP 10497-03-000, SCREW G39-08-12B
- 4 CLAMP 83610-01-000, SCREW G11-10-16B
- 3 USE WIRE-TIE 8343-02-000 TO SECURE WIRES TO FLOOR SUPPORT FRAME AT LEAST ONCE EVERY 600MM.
- 2 SEE WIRING INSTL-FRONT END FOR ADDITIONAL INFORMATION.

1. LEGEND: — WINNEBAGO: - - - - - CABLE: - - - - - CHASSIS SUPPLIED WIRING.

NOTES:

- IFS FRTL 330HP 7.2L 6SPD AL WHLS
- IFA FRTL 27,910 300 5.9L 5-SP
- 670 GEN-7.5KW-ONAN-QUIET DIESEL
- 64J SEAT PED-6-WAY DR/PASS POWER
- 13X INVERTER/CHARGER 2.0 KW
- 22W BATTERY-SECOND
- 20C SOUND SYS. DLX. W/O-SURROUND
- 265 CODES/STANDARDS-CSA/CMVSS
- 1B1 CODES/STANDARDS USA

1B1 265 IFA IFS	
WINNEBAGO	
COPYRIGHT 2006 WINNEBAGO INDUSTRIES, INC.	
DFTR	ORIG. DATE
CHKR	ALL DIMENSIONS ARE IN MILLIMETERS
P.E.	
M.E.	FIRST USED
DSNR	06 P36G
UNSPECIFIED TOLERANCES ARE:	MATERIAL:
WHOLE DIM (X)	:
ONE-PLACE (X.X)	:
TWO-PLACE (X.XX)	:
ANGLE	:
THIRD ANGLE PROJECTION	
DO NOT SCALE DRAWING	
TITLE: WIRING INSTL-CHASSIS	
SHEET 1 OF 3	PART NO 153547 REV
REF:	1 6/16/2006

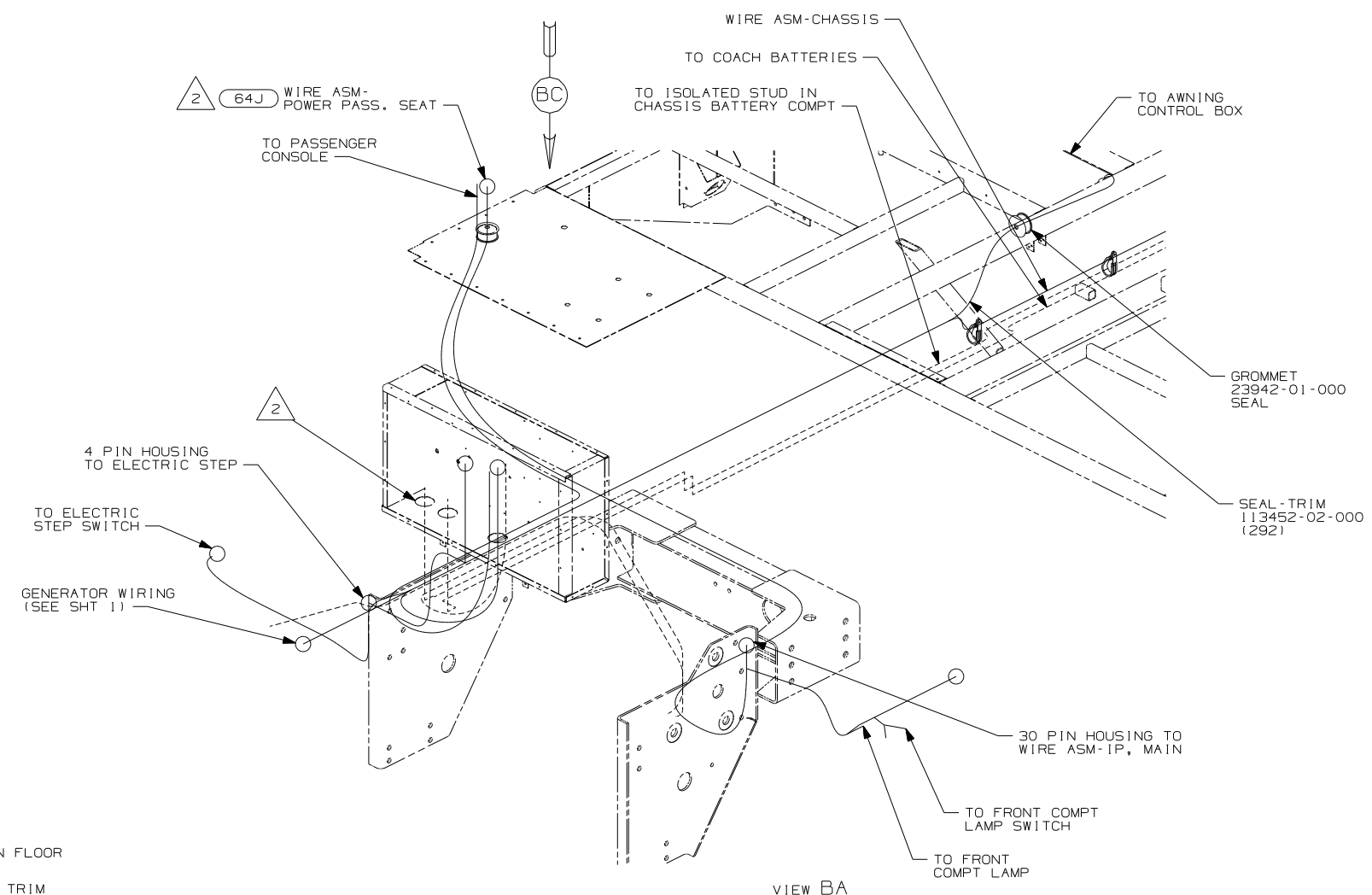

VIEW BA

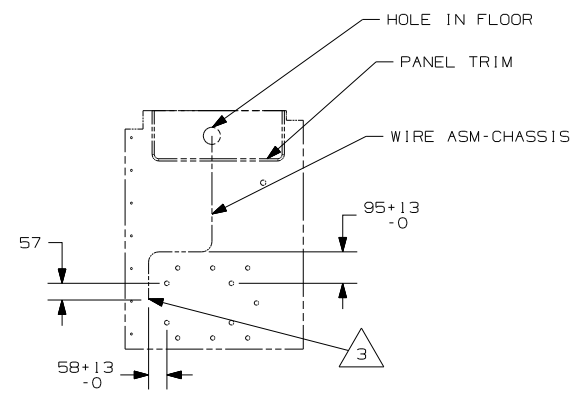

DETAIL BC (64J)

- (64J) SEAT PED-6-WAY DR/PASS POWER
- (13X) INVERTER/CHARGER 2.0 KW
- (22W) BATTERY-SECOND
- (265) CODES/STANDARDS-CSA/CMVSS
- (1B1) CODES/STANDARDS USA

FIRST USED		06 P36G	
DO NOT SCALE DRAWING			
TITLE: WIRING INSTL-CHASSIS			
SHEET 2	PART NO	153547	REV

- NOTES:
- 3 LEAVE 675±50MM OF WIRE AT END POINT OF PATH.
 - 2 SEE WIRING INSTL-FRONT END FOR ADDITIONAL INFORMATION.
 - 1 CLAMP WIRES TO TUBES WITH ENOUGH SLACK TO PULL BATTERY TRAY OUT 20 INCHES.

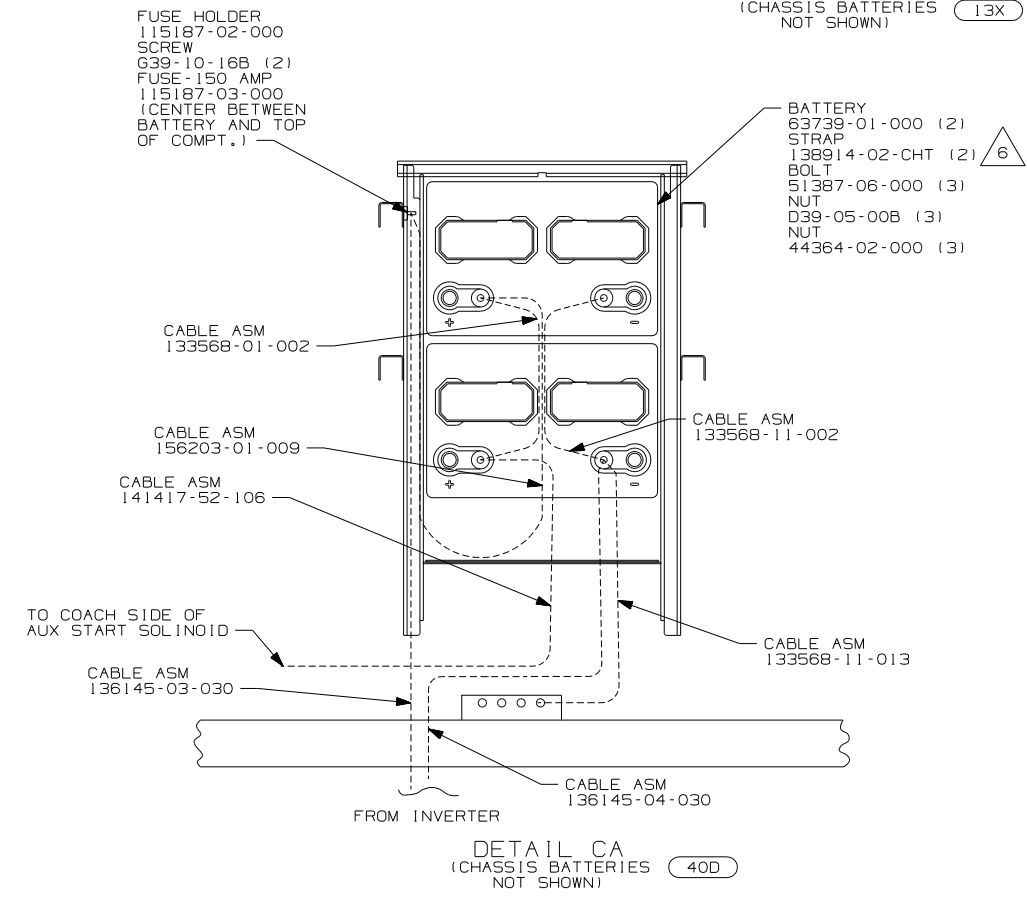
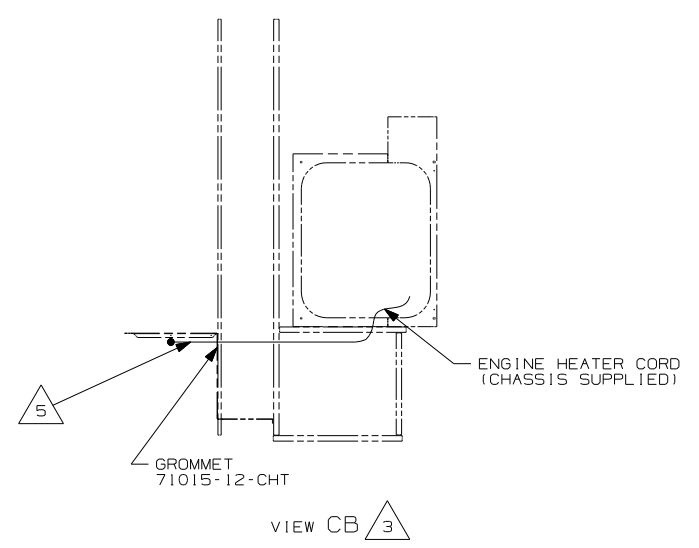
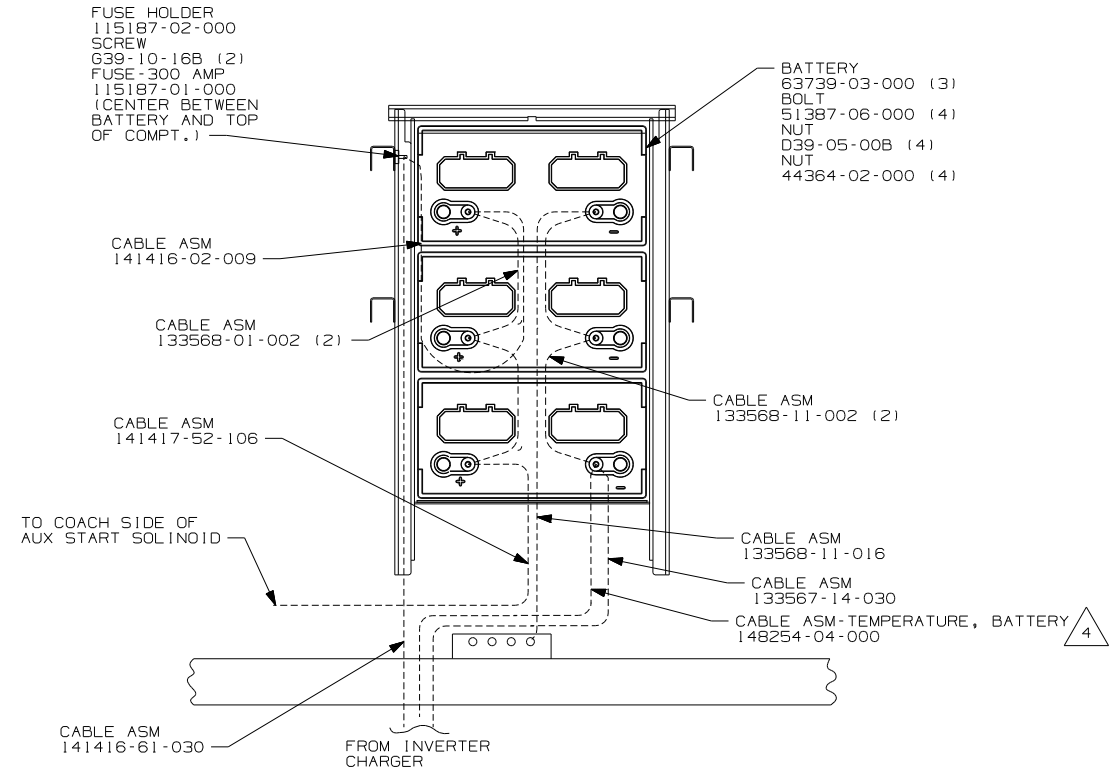
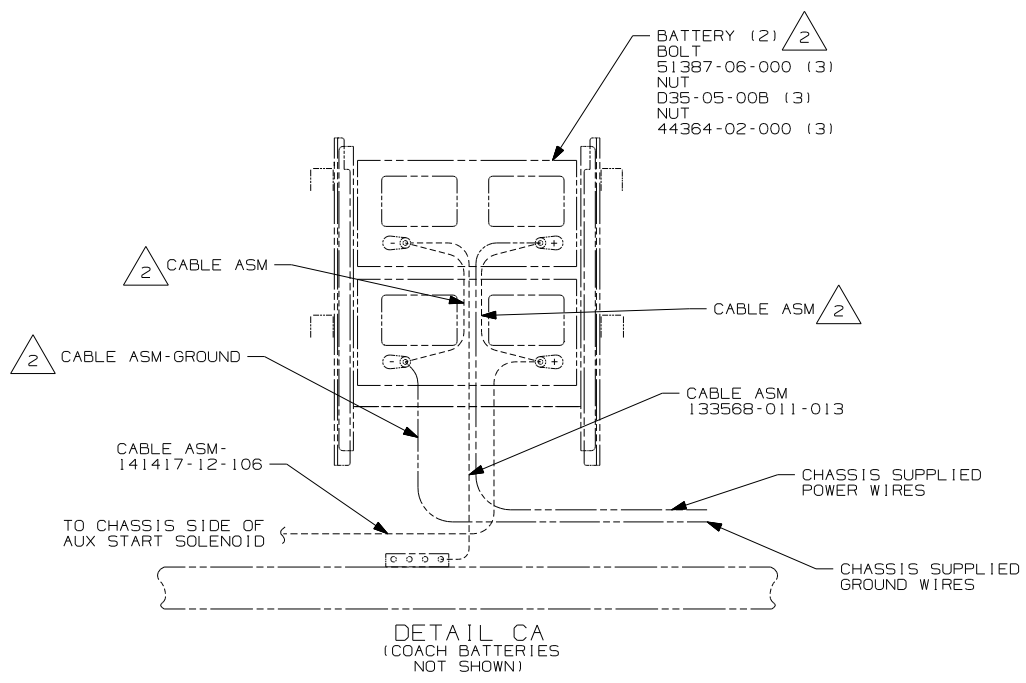

- 6 DISCARD BATTERY STRAP SUPPLIED WITH BATTERY TRAY.
- 5 ENGINE HEATER CORD MUST PASS THRU COMPT AT LEAST 250MM TO PLUG INTO RECEPTACLE.
- 4 CONNECT RING TERMINAL OF CABLE ASM-TEMP,BATTERY TO NEGATIVE POST AS SHOWN AND ROUTE CABLE WITH NEGATIVE BATTERY CABLE TO INVERTER.
- 3 SECURE CORD AWAY FROM ALL MOVING PARTS AND EXHAUST WITH WIRE-TIE 93147-01-000 AS REQUIRED.
- 2 SUPPLIED WITH CHASSIS

1. LEGEND: — WINNEBAGO: - - - - - CABLE: - - - - - CHASSIS SUPPLIED WIRING.

NOTES:

- 40D INVERTER-DC/AC,600 WATT
- 13X INVERTER/CHARGER 2.0 KW
- 265 CODES/STANDARDS-CSA/CMVSS
- 1B1 CODES/STANDARDS USA

FIRST USED	06 P36G
TITLE	DO NOT SCALE DRAWING
	WIRING INSTL-CHASSIS
SHEET 3	PART NO 153547 REV