



**DANGER**

**Danger of electrical shock, burns or death.** Always remove all power sources before attempting any repair, service or diagnostic work. Power can be present from shore power, generator, inverter or battery. All power sources must be disabled and secured before performing any service.



**CAUTION**

If you lack the skills, tools or equipment to perform diagnostic or repair work leave such work to an authorized Winnebago Industries dealer or other qualified shop.



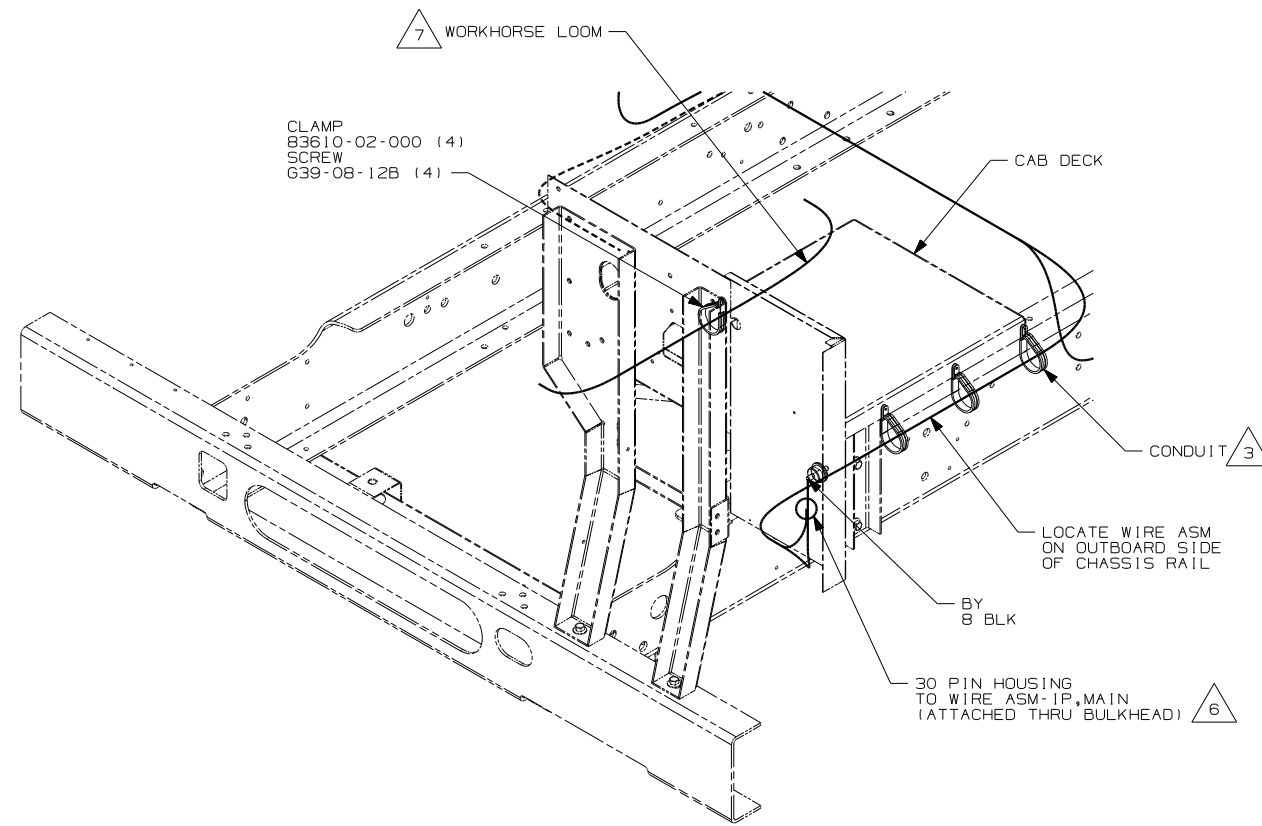

VIEW BA-BA

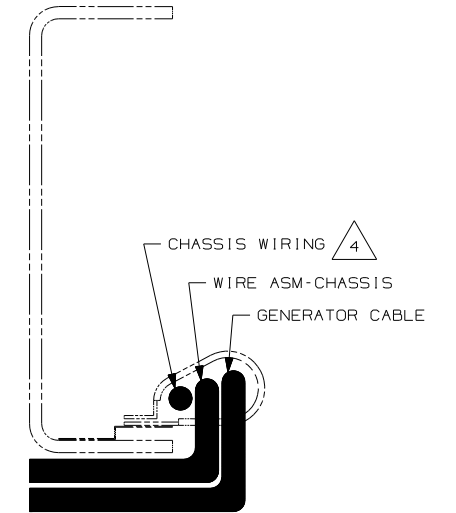

VIEW BB-BB

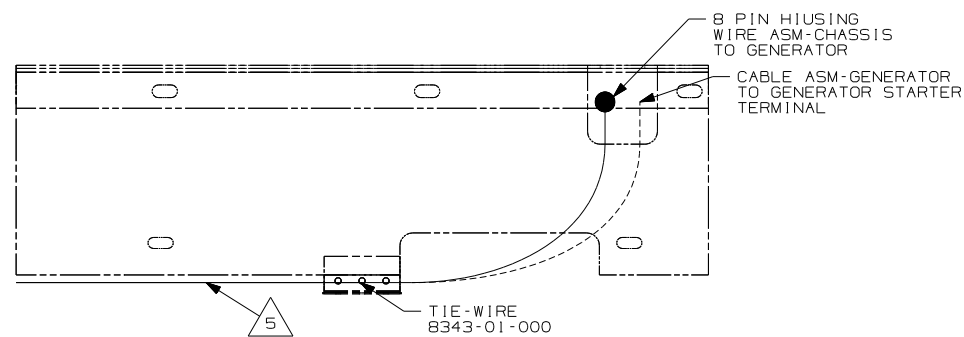

VIEW BC-BC

- 7 CLAMP WORKHORSE ENGINE HARNESS TO CAB DECK TO PROTECT HARNESS FROM DAMAGE.
- 6 SEE WIRING INSTL-FRONT END FOR ADDITIONAL INFORMATION.
- 5 SECURE SO WIRES DO NOT CONTACT EXHAUST.
- 4 SUPPLIED WITH CHASSIS.
- 3 COVER WITH CONDUIT 41953-10-000 AND 41953-11-000 AS REQUIRED.

2. SECURE CONDUIT 41953-09, -10, -11, -13, AND -14 OVER ALL WIRES IN CONTACT WITH SHARP EDGES.

1. LEGEND: — WINNEBAGO: - - - - - CABLE: - - - - - CHASSIS SUPPLIED WIRING.

NOTES:

FOR ELECTRICAL TORQUE SPECIFICATIONS SEE DWG NO. 128783-01-000

FOR ELECTRICAL CALLOUTS SEE DWG NO. 121339-01-000

- IPV WORKHORSE 24,000#-22.5 TIRE
- 265 CODES/STANDARDS-CSA/CMVSS
- 1B1 CODES/STANDARDS USA

1B1 265 IPV

FIRST USED	06 G38J
DO NOT SCALE DRAWING	
TITLE:	WIRING INSTL-CHASSIS
SHEET 2	PART NO 153784

UNMARKED 6 GA. BLACK WIRE FROM WIRE ASM-INVERTER CONNECTS TO FUSE BLOCK AS SHOWN

REMOVE 6 GA. BLACK WIRE MARKED WITH RED TAPE FROM WIRE ASM-INVERTER AND ATTACH ONE END TO FUSE BLOCK AND THE OTHER END TO THE POSITIVE BATTERY POST AS SHOWN.

UNMARKED 6 & 8 GA. GREEN WIRES FROM WIRE ASM-INVERTER CONNECTS TO GROUND BAR.

INVERTER CONNECTIONS IN COMPARTMENT. SEE WIRING INSTL-BODY, 110V FOR ADDITIONAL INFORMATION

VIEW CA (40D)

2. SECURE CONDUIT 41953, TAB AS REQUIRED, OVER ALL WIRES IN CONTACT WITH SHARP EDGES.

1. LEGEND: — WINNEBAGO: - - - - - CABLE: - - - - - CHASSIS SUPPLIED WIRING.

NOTES:

- (40D) INVERTER-DC/AC, 600 WATT
- (265) CODES/STANDARDS-CSA/CMVSS
- (1B1) CODES/STANDARDS USA

FIRST USED	
06 G38J	
DO NOT SCALE DRAWING	
TITLE	
WIRING INSTL-CHASSIS	
SHEET 3	PART NO 153784