



**DANGER**

**Danger of electrical shock, burns or death.** Always remove all power sources before attempting any repair, service or diagnostic work. Power can be present from shore power, generator, inverter or battery. All power sources must be disabled and secured before performing any service.



**CAUTION**

If you lack the skills, tools or equipment to perform diagnostic or repair work leave such work to an authorized Winnebago Industries dealer or other qualified shop.

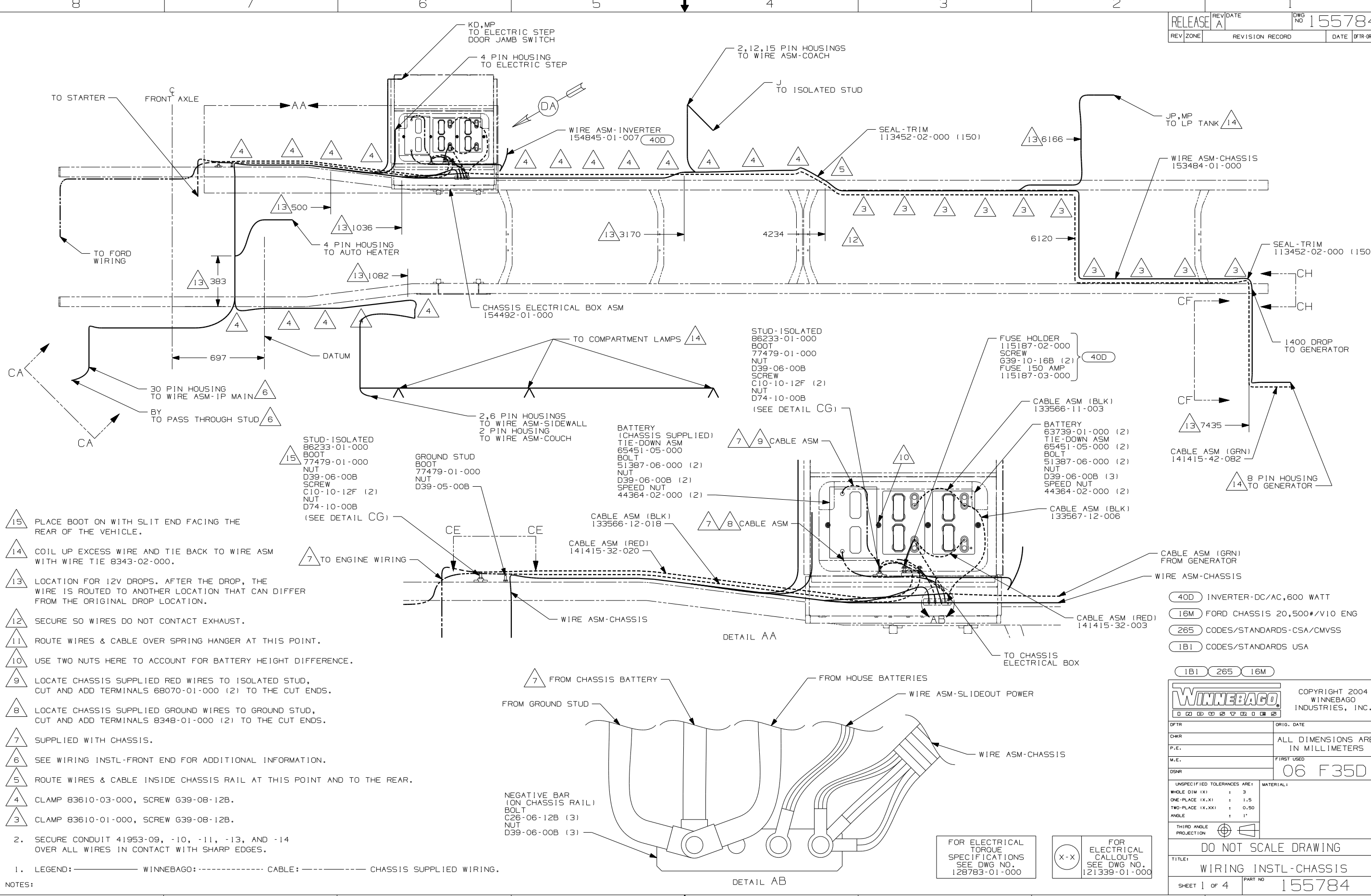

- 15 PLACE BOOT ON WITH SLIT END FACING THE REAR OF THE VEHICLE.
  - 14 COIL UP EXCESS WIRE AND TIE BACK TO WIRE ASM WITH WIRE TIE 8343-02-000.
  - 13 LOCATION FOR 12V DROPS. AFTER THE DROP, THE WIRE IS ROUTED TO ANOTHER LOCATION THAT CAN DIFFER FROM THE ORIGINAL DROP LOCATION.
  - 12 SECURE SO WIRES DO NOT CONTACT EXHAUST.
  - 11 ROUTE WIRES & CABLE OVER SPRING HANGER AT THIS POINT.
  - 10 USE TWO NUTS HERE TO ACCOUNT FOR BATTERY HEIGHT DIFFERENCE.
  - 9 LOCATE CHASSIS SUPPLIED RED WIRES TO ISOLATED STUD, CUT AND ADD TERMINALS 68070-01-000 (2) TO THE CUT ENDS.
  - 8 LOCATE CHASSIS SUPPLIED GROUND WIRES TO GROUND STUD, CUT AND ADD TERMINALS 8348-01-000 (2) TO THE CUT ENDS.
  - 7 SUPPLIED WITH CHASSIS.
  - 6 SEE WIRING INSTL-FRONT END FOR ADDITIONAL INFORMATION.
  - 5 ROUTE WIRES & CABLE INSIDE CHASSIS RAIL AT THIS POINT AND TO THE REAR.
  - 4 CLAMP 83610-03-000, SCREW G39-08-12B.
  - 3 CLAMP 83610-01-000, SCREW G39-08-12B.
2. SECURE CONDUIT 41953-09, -10, -11, -13, AND -14 OVER ALL WIRES IN CONTACT WITH SHARP EDGES.
1. LEGEND: — WINNEBAGO: - - - - - CABLE: - - - - - CHASSIS SUPPLIED WIRING.

NOTES:

NEGATIVE BAR (ON CHASSIS RAIL)  
 BOLT C26-06-12B (3)  
 NUT D39-06-00B (3)

FOR ELECTRICAL TORQUE SPECIFICATIONS SEE DWG NO. 128783-01-000

FOR ELECTRICAL CALLOUTS SEE DWG NO. 121339-01-000

WINNEBAGO COPYRIGHT 2004 WINNEBAGO INDUSTRIES, INC.

DFTR	ORIG. DATE
CHKR	ALL DIMENSIONS ARE IN MILLIMETERS
P.E.	FIRST USED
M.E.	06 F35D
DSNR	

UNSPECIFIED TOLERANCES ARE: MATERIAL:

WHOLE DIM (X)	: 3
ONE-PLACE (X.X)	: 1.5
TWO-PLACE (X.XX)	: 0.50
ANGLE	: 1°

THIRD ANGLE PROJECTION

DO NOT SCALE DRAWING

TITLE: WIRING INSTL-CHASSIS

SHEET 1 of 4 PART NO. 155784

REF: 1 8/5/2005

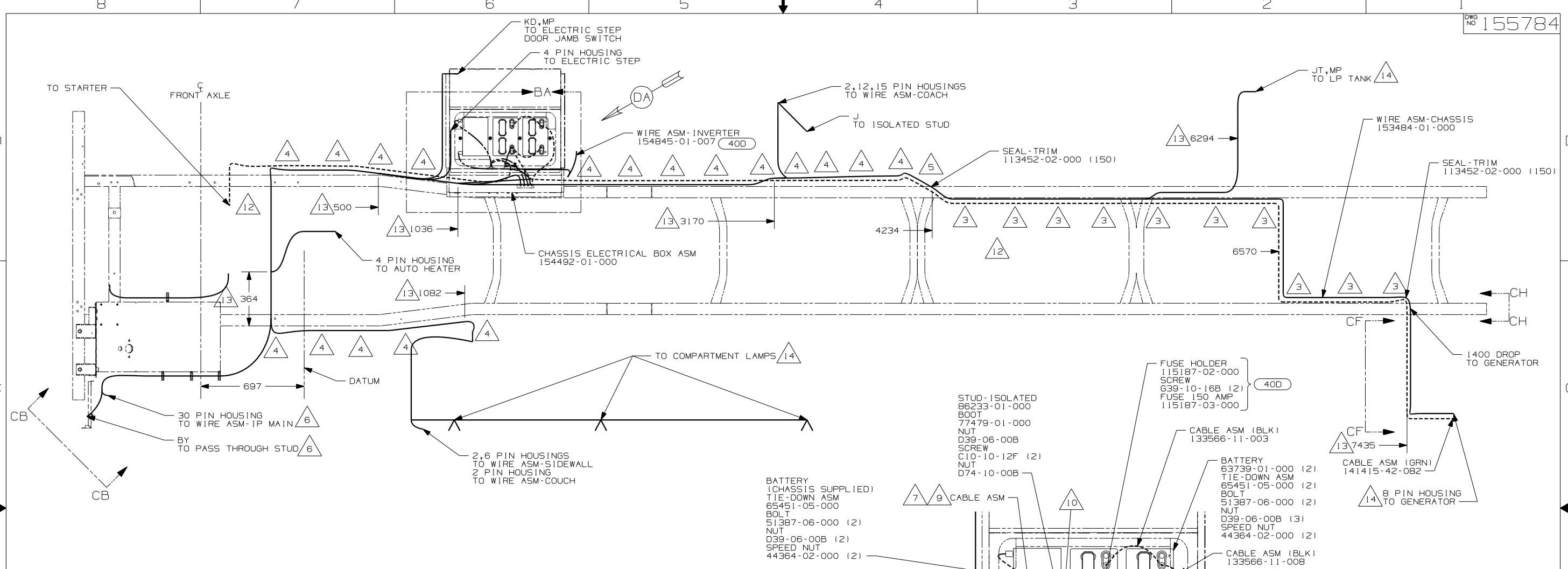

- 15 ONLY USED ON 190" CHASSIS
  - 14 COIL UP EXCESS WIRE AND TIE BACK TO WIRE ASM WITH WIRE TIE 8343-02-000.
  - 13 LOCATION FOR 12V DROPS. AFTER THE DROP, THE WIRE IS ROUTED TO ANOTHER LOCATION THAT CAN DIFFER FROM THE ORIGINAL DROP LOCATION
  - 12 SECURE SO WIRES DO NOT CONTACT EXHAUST.
  - 11 ROUTE WIRES & CABLE OVER SPRING HANGER AT THIS POINT.
  - 10 USE TWO NUTS HERE TO ACCOUNT FOR BATTERY HEIGHT DIFFERENCE.
  - 9 LOCATE CHASSIS SUPPLIED RED WIRES TO ISOLATED STUD, CUT AND ADD TERMINAL 68070-01-000 TO THE CUT END.
  - 8 LOCATE CHASSIS SUPPLIED GROUND WIRES TO GROUND BAR, CUT AND ADD TERMINAL 8348-01-000 TO THE CUT END.
  - 7 SUPPLIED WITH CHASSIS.
  - 6 SEE WIRING INSTL-FRONT END FOR ADDITIONAL INFORMATION.
  - 5 ROUTE WIRES & CABLE INSIDE CHASSIS RAIL AT THIS POINT AND TO THE REAR.
  - 4 CLAMP 83610-03-000, SCREW G39-08-12B.
  - 3 CLAMP 83610-01-000, SCREW G39-08-12B.
2. SECURE CONDUIT 41953-09, -10, -11, -13, AND -14 OVER ALL WIRES IN CONTACT WITH SHARP EDGES.
1. LEGEND: — WINNEBAGO: - - - - - CABLE: - - - - - CHASSIS SUPPLIED WIRING.

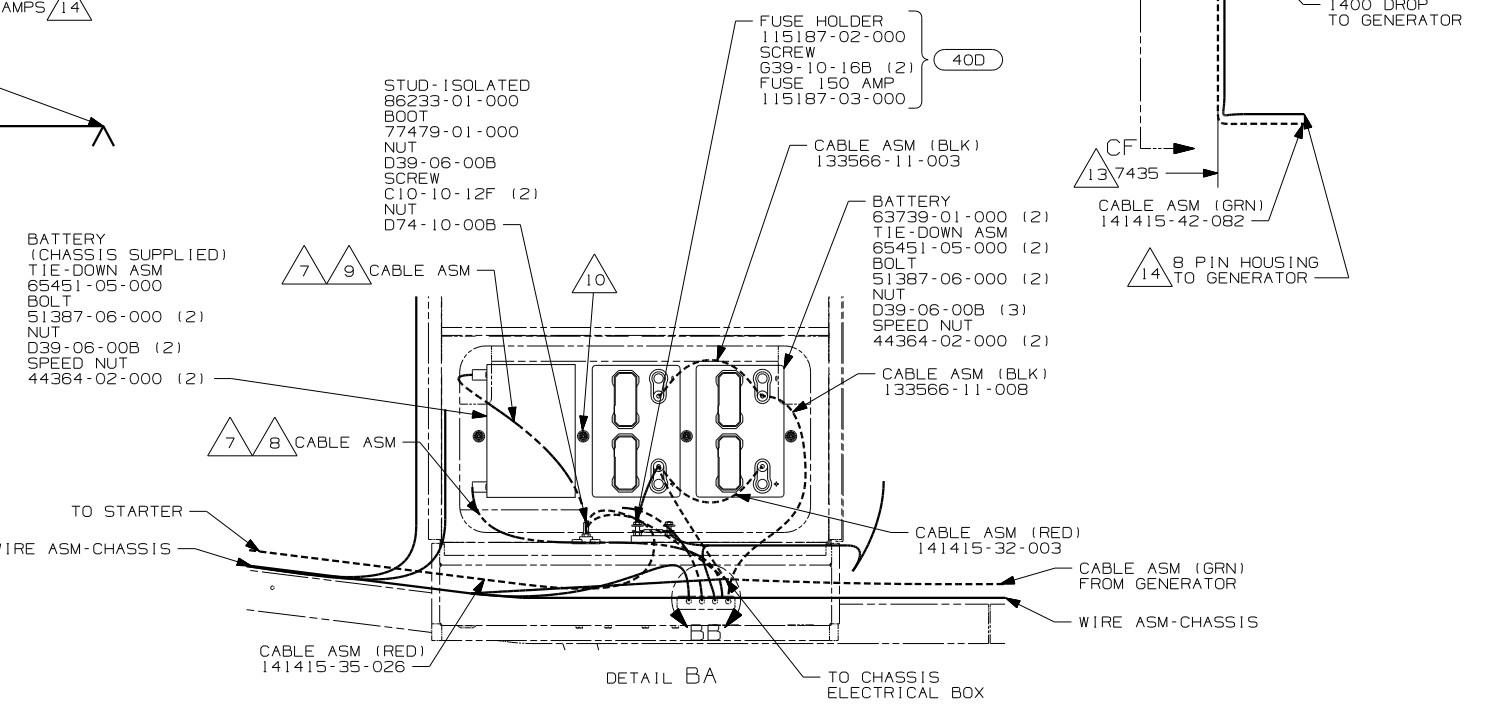
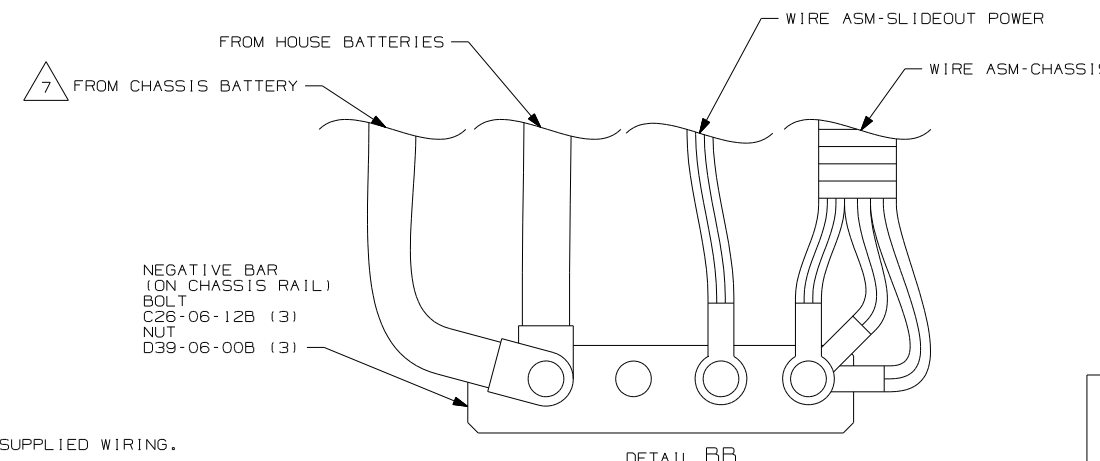

- 40D INVERTER-DC/AC, 600 WATT
- IPN WORKHORSE 20, 700#
- 265 CODES/STANDARDS-CSA/CMVSS
- 1B1 CODES/STANDARDS USA

FOR ELECTRICAL TORQUE SPECIFICATIONS SEE DWG NO. 128783-01-000

FOR ELECTRICAL CALLOUTS SEE DWG NO. 121339-01-000

FIRST USED	
06 F35D	
DO NOT SCALE DRAWING	
TITLE: WIRING INSTL-CHASSIS	
SHEET 2	PART NO 155784

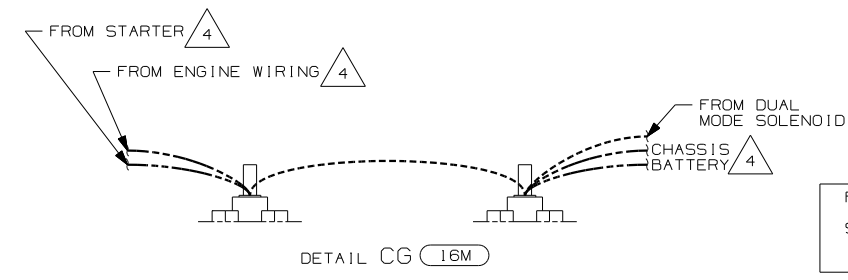
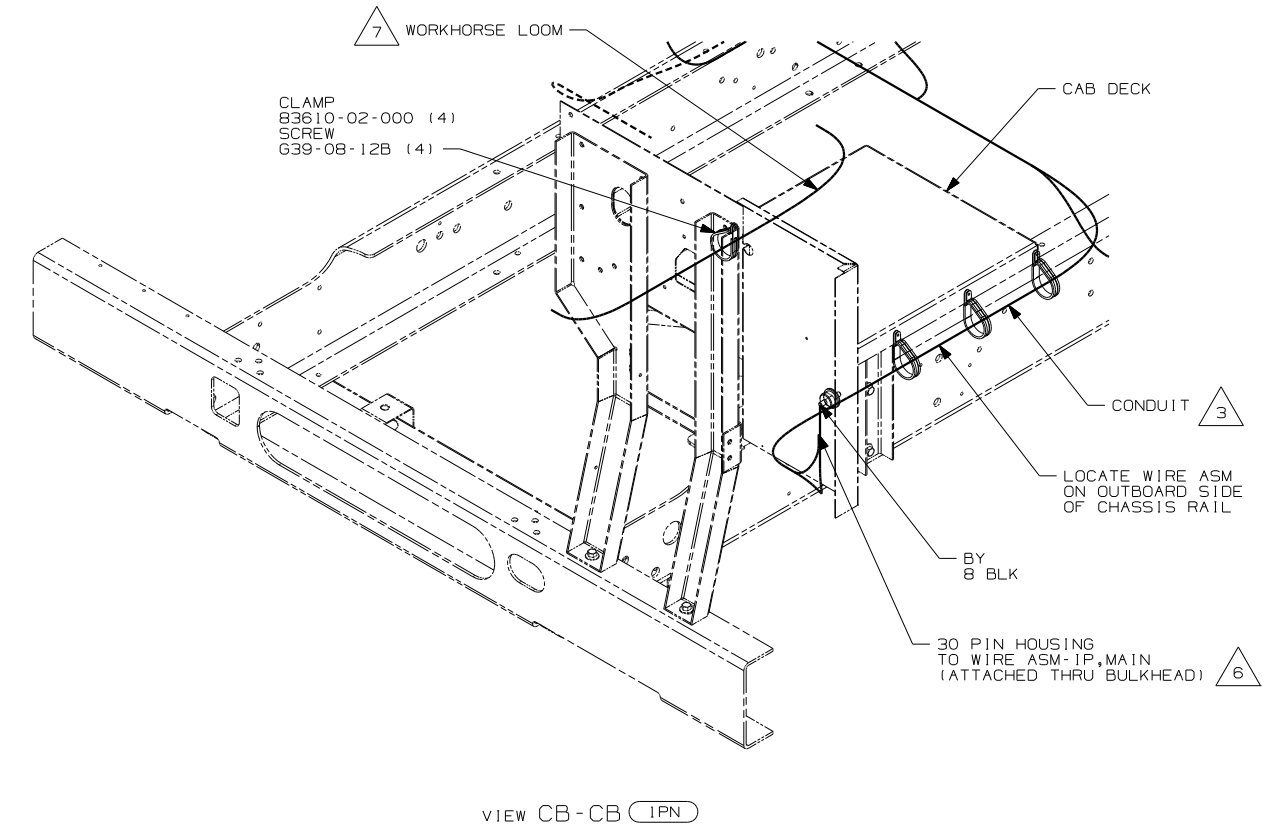
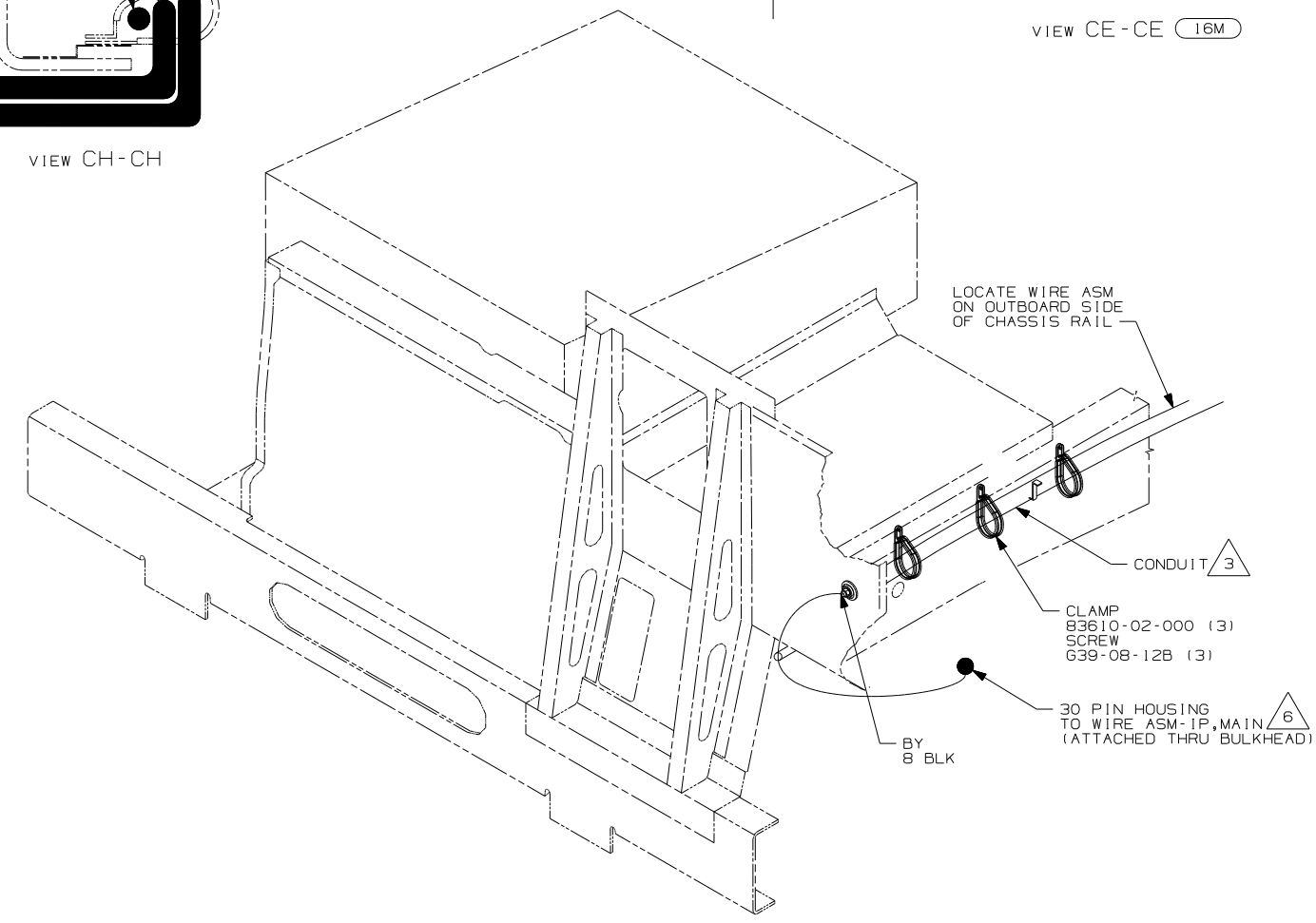
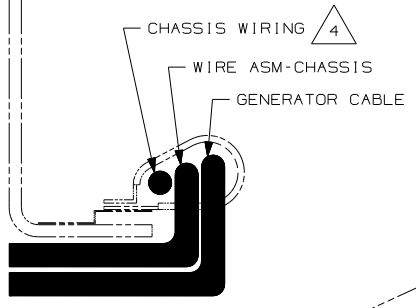
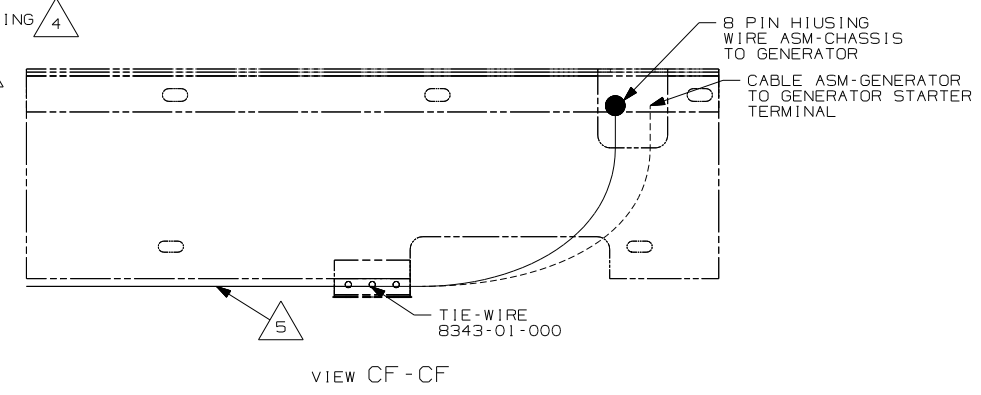
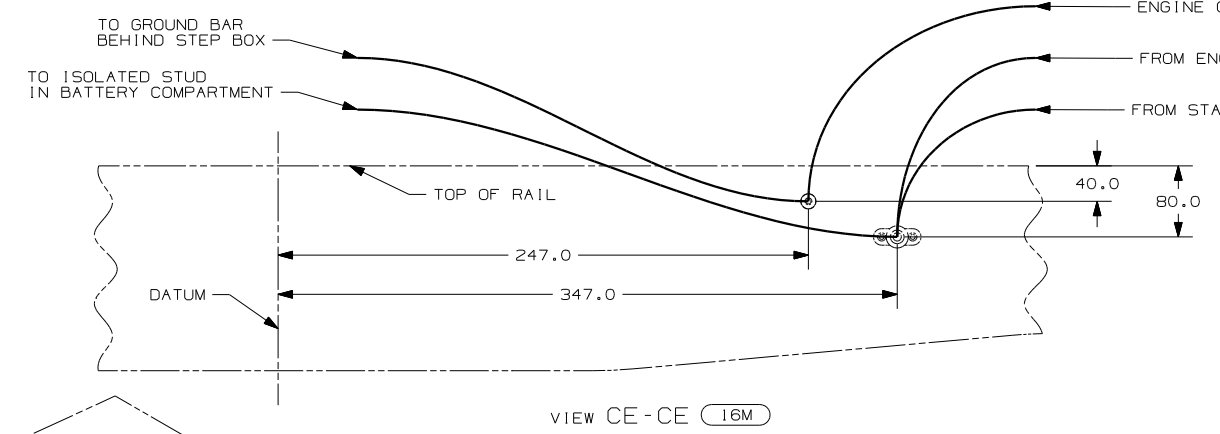

- 7 CLAMP WORKHORSE ENGINE HARNESS TO CAB DECK TO PROTECT HARNESS FROM DAMAGE.
- 6 SEE WIRING INSTL-FRONT END FOR ADDITIONAL INFORMATION.
- 5 SECURE SO WIRES DO NOT CONTACT EXHAUST.
- 4 SUPPLIED WITH CHASSIS.
- 3 COVER WITH CONDUIT 41953-10-000 AND 41953-11-000 AS REQUIRED.

2. SECURE CONDUIT 41953-09, -10, -11, -13, AND -14 OVER ALL WIRES IN CONTACT WITH SHARP EDGES.

1. LEGEND: — WINNEBAGO; - - - CABLE; - - - CHASSIS SUPPLIED WIRING.

NOTES:

- (1PN) WORKHORSE 20,700#
- (16M) FORD CHASSIS 20,500#/V10 ENG
- (265) CODES/STANDARDS-CSA/CMVSS
- (1B1) CODES/STANDARDS USA

FOR ELECTRICAL TORQUE SPECIFICATIONS SEE DWG NO. 128783-01-000

(X-X) FOR ELECTRICAL CALLOUTS SEE DWG NO. 121339-01-000

FIRST USED	06 F35D
TITLE	DO NOT SCALE DRAWING
TITLE	WIRING INSTL-CHASSIS
SHEET 3	PART NO 155784

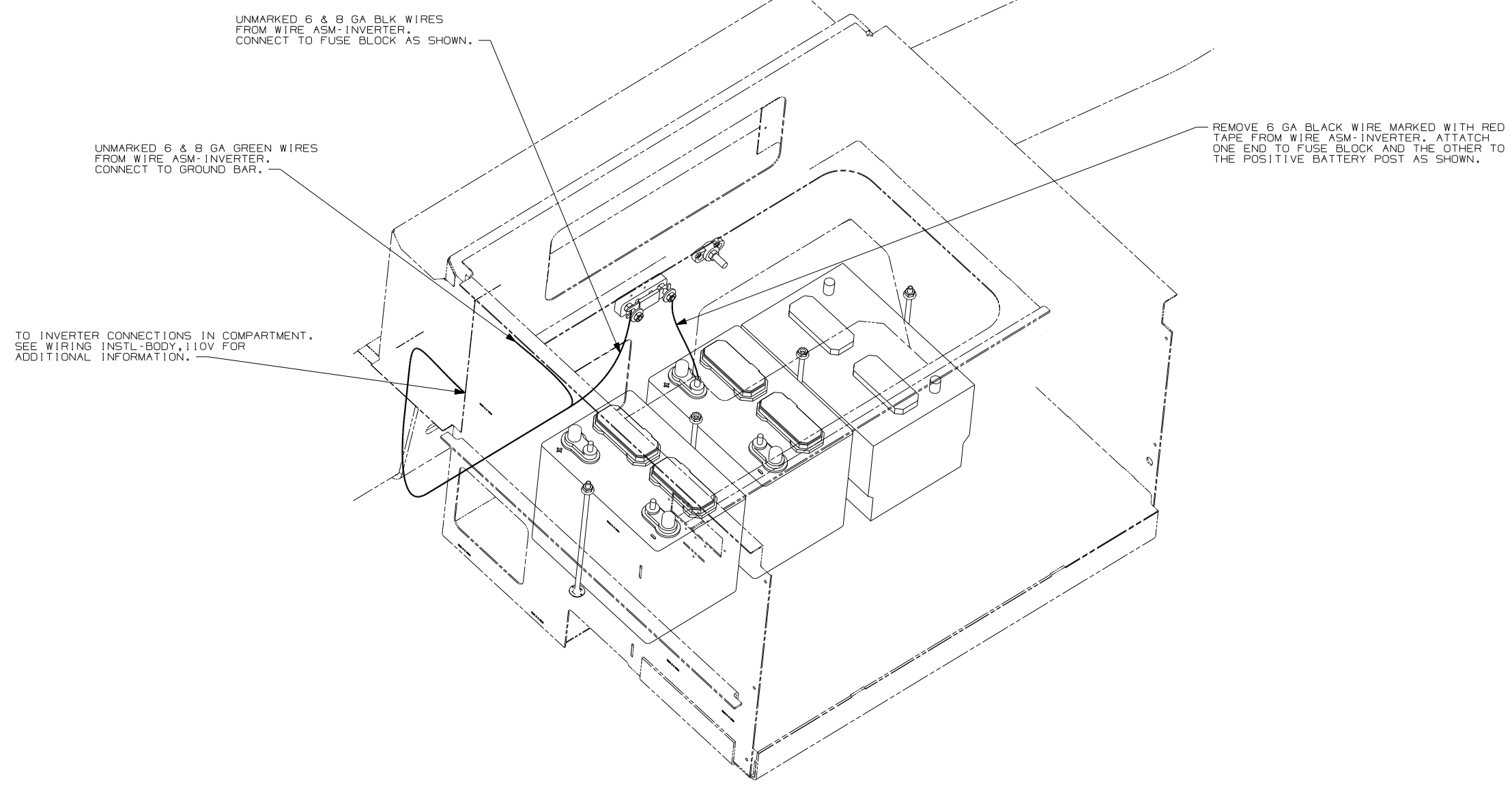

DETAIL DA 40D

- 40D INVERTER-DC/AC, 600 WATT
- 265 CODES/STANDARDS-CSA/CMVSS
- 1B1 CODES/STANDARDS USA

FIRST USED	
06 F35D	
DO NOT SCALE DRAWING	
TITLE:	
WIRING INSTL-CHASSIS	
SHEET 4	PART NO
	155784

2. SECURE CONDUIT 41953, TAB AS REQUIRED, OVER ALL WIRES IN CONTACT WITH SHARP EDGES.

1. LEGEND: — WINNEBAGO: - - - - - CABLE: - - - - - CHASSIS SUPPLIED WIRING.

NOTES:

FOR ELECTRICAL TORQUE SPECIFICATIONS SEE DWG NO. 128783-01-000

FOR ELECTRICAL CALLOUTS SEE DWG NO. 121339-01-000