



DANGER

Danger of electrical shock, burns or death. Always remove all power sources before attempting any repair, service or diagnostic work. Power can be present from shore power, generator, inverter or battery. All power sources must be disabled and secured before performing any service.



CAUTION

If you lack the skills, tools or equipment to perform diagnostic or repair work leave such work to an authorized Winnebago Industries dealer or other qualified shop.

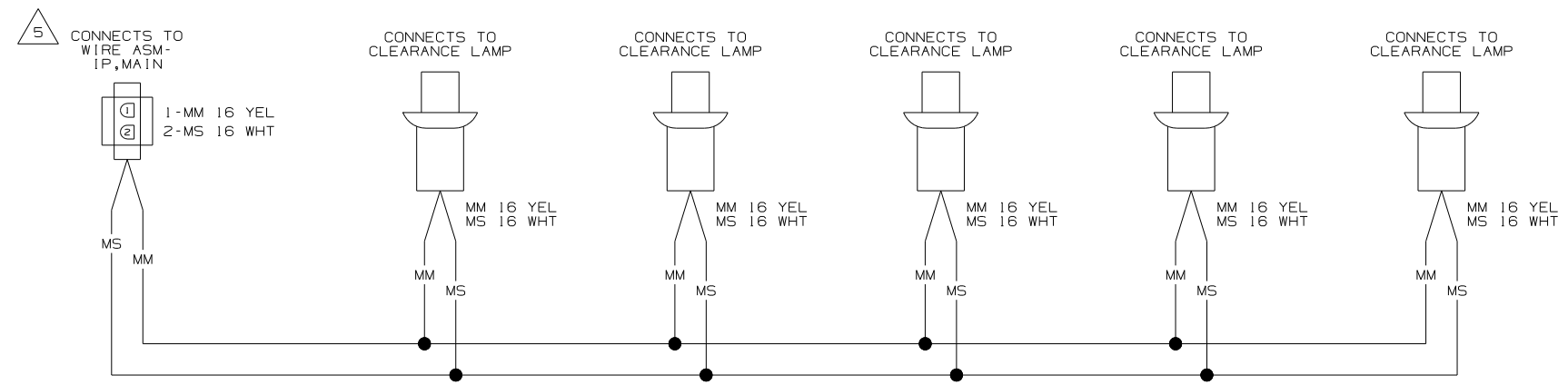

WIRING DIAGRAM-CLEARANCE LAMPS
(WIRE ASM 126486-01 REV-F)

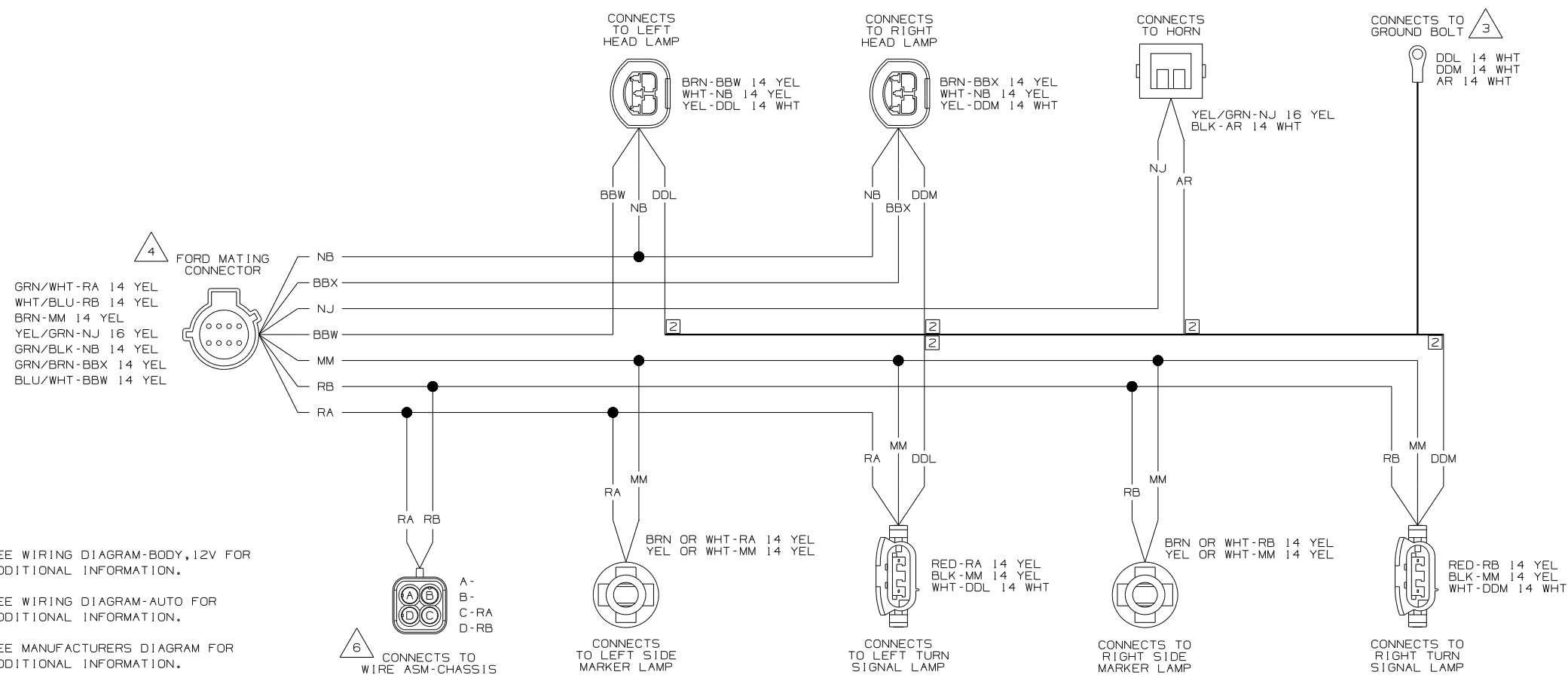

WIRING DIAGRAM-HEADLAMPS
(WIRE ASM 149398-05 REV-L)
(FORD CHASSIS)
(ITASCA)

- 6 SEE WIRING DIAGRAM-BODY, 12V FOR ADDITIONAL INFORMATION.
- 5 SEE WIRING DIAGRAM-AUTO FOR ADDITIONAL INFORMATION.
- 4 SEE MANUFACTURERS DIAGRAM FOR ADDITIONAL INFORMATION.
- 3 GROUNDS ARE SHOWN AS A SINGLE LINE FOR EASE IN TRACING. EACH GROUND CIRCUIT IS SEPERATE IN THE HARNESS.
- 2 NOT A SPLICE POINT. INDICATES ENTRY INTO WIRING HARNESS.
1. SPLICES ARE THEORETICAL AND MAY DIFFER IN THE HARNESS.

NOTES:

WINNEBAGO		COPYRIGHT 2004 WINNEBAGO INDUSTRIES, INC.	
DFTR	ORIG. DATE	ALL DIMENSIONS ARE IN MILLIMETERS	
CHKR		FIRST USED 06 F-SER	
P.E.		UNSPECIFIED TOLERANCES ARE:	
M.E.		WHOLE DIM (X)	:
DSNR		ONE-PLACE (X.X)	:
		TWO-PLACE (X.XX)	:
		ANGLE	:
THIRD ANGLE PROJECTION		MATERIAL:	
DO NOT SCALE DRAWING			
TITLE: WIRING DIAGRAM-AUTO LAMPS			
SHEET 1 of 6	PART NO	152117	
REF:		1 11/3/2005	

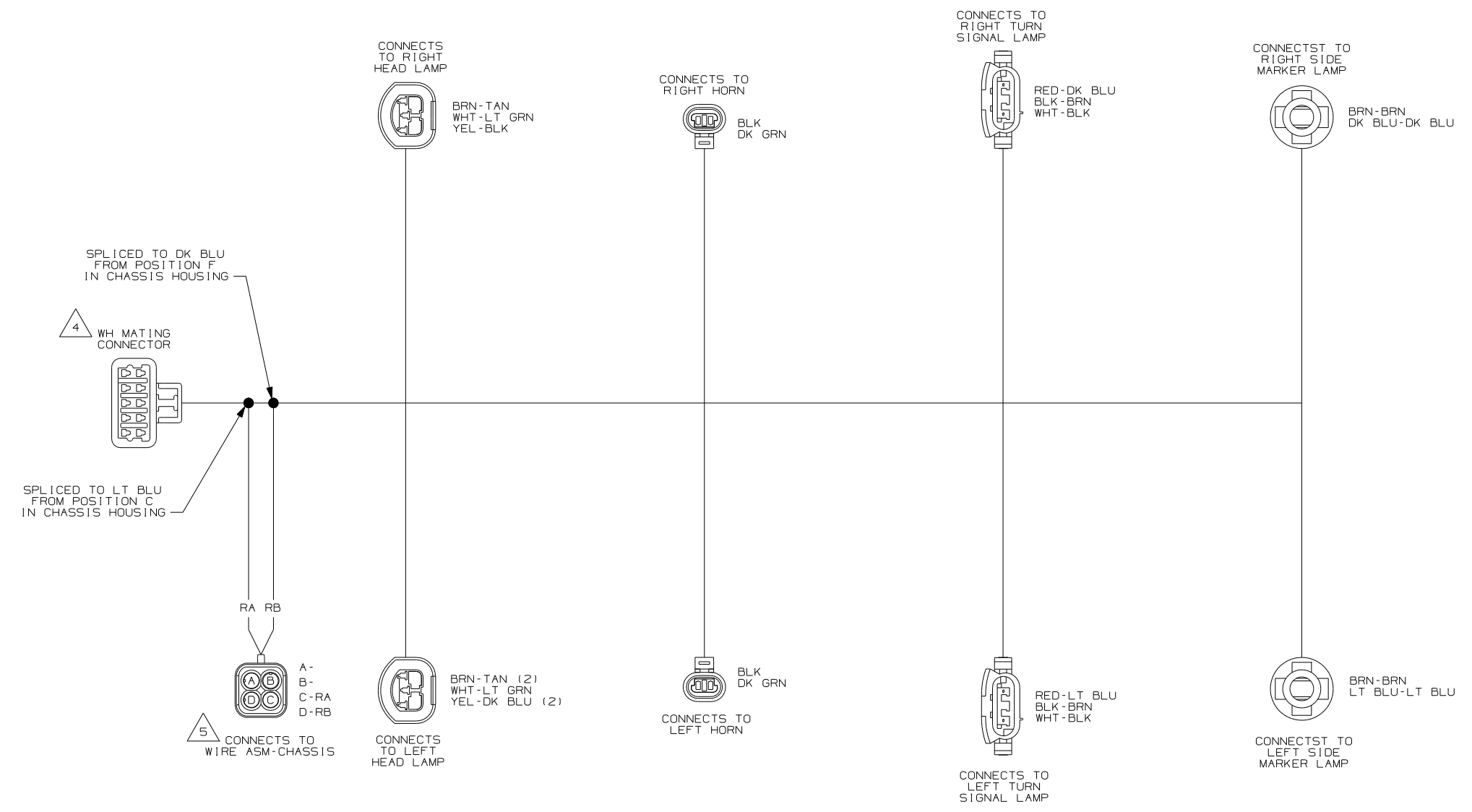

- 5 SEE WIRING DIAGRAM-BODY, 12V FOR ADDITIONAL INFORMATION.
 - 4 SEE MANUFACTURERS DIAGRAM FOR ADDITIONAL INFORMATION.
 - 3 GROUNDS ARE SHOWN AS A SINGLE LINE FOR EASE IN TRACING. EACH GROUND CIRCUIT IS SEPERATE IN THE HARNESS.
 - 2 NOT A SPLICE POINT. INDICATES ENTRY INTO WIRING HARNESS.
1. SPLICES ARE THEORETICAL AND MAY DIFFER IN THE HARNESS.

NOTES:

WIRING DIAGRAM-HEADLAMPS
 (WIRE ASM 149398-06 REV-L)
 (WORKHORSE CHASSIS)
 (TASCA)

FIRST USED	06 F-SER	
TITLE	DO NOT SCALE DRAWING	
	WIRING DIAGRAM-AUTO LAMPS	
SHEET 2	PART NO	152117

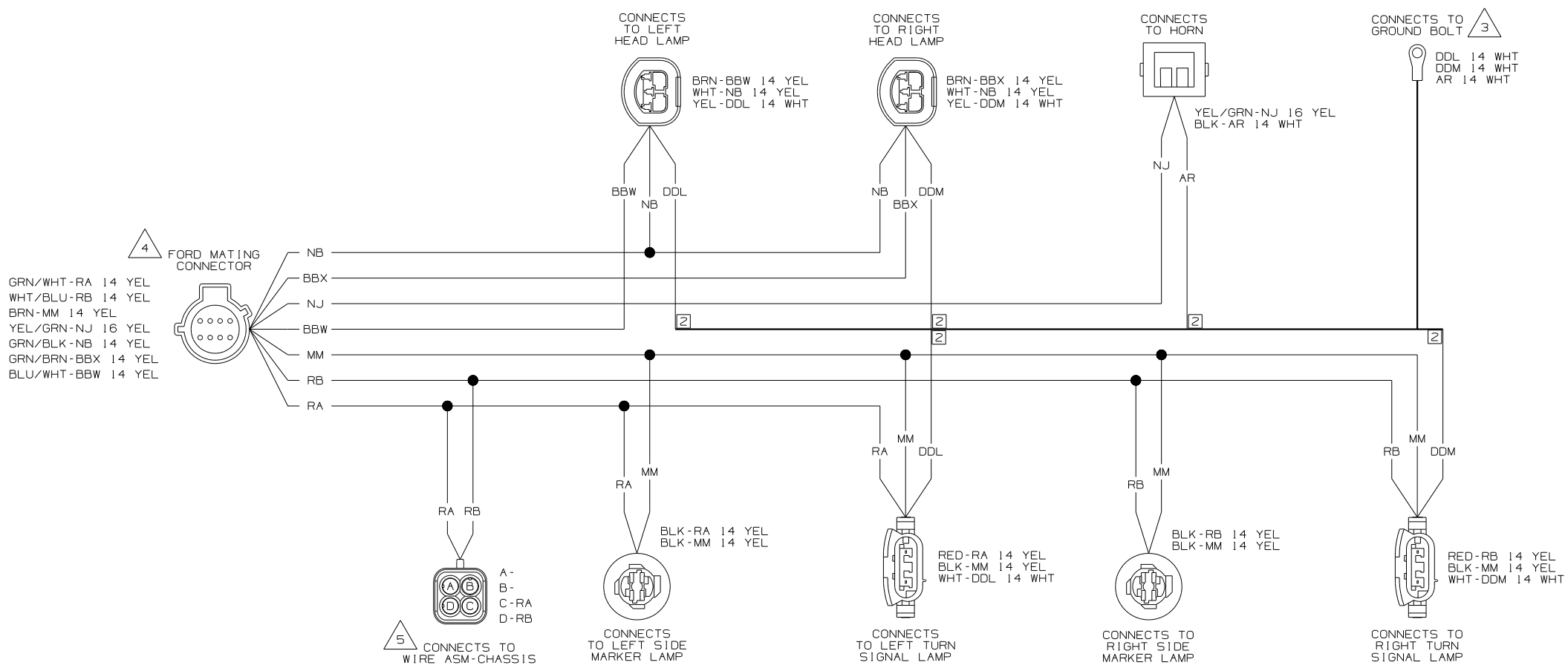

GRN/WHT-RA 14 YEL
 WHT/BLU-RB 14 YEL
 BRN-MM 14 YEL
 YEL/GRN-NJ 16 YEL
 GRN/BLK-NB 14 YEL
 GRN/BRN-BBX 14 YEL
 BLU/WHT-BBW 14 YEL

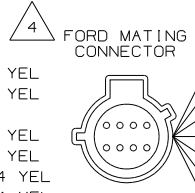

5 CONNECTS TO WIRE ASM-CHASSIS

CONNECTS TO LEFT SIDE MARKER LAMP

CONNECTS TO LEFT TURN SIGNAL LAMP

CONNECTS TO RIGHT SIDE MARKER LAMP

CONNECTS TO RIGHT TURN SIGNAL LAMP

- 5 SEE WIRING DIAGRAM-BODY,12V FOR ADDITIONAL INFORMATION.
 - 4 SEE MANUFACTURERS DIAGRAM FOR ADDITIONAL INFORMATION.
 - 3 GROUNDS ARE SHOWN AS A SINGLE LINE FOR EASE IN TRACING. EACH GROUND CIRCUIT IS SEPERATE IN THE HARNESS.
 - 2 NOT A SPLICE POINT. INDICATES ENTRY INTO WIRING HARNESS.
1. SPLICES ARE THEORETICAL AND MAY DIFFER IN THE HARNESS.

WIRING DIAGRAM-HEADLAMPS
 (WIRE ASM 149398-07 REV-L)
 (FORD CHASSIS)
 (WINNEBAGO)

FIRST USED	06 F-SER
TITLE	DO NOT SCALE DRAWING
	WIRING DIAGRAM-AUTO LAMPS
SHEET 3	PART NO 152117

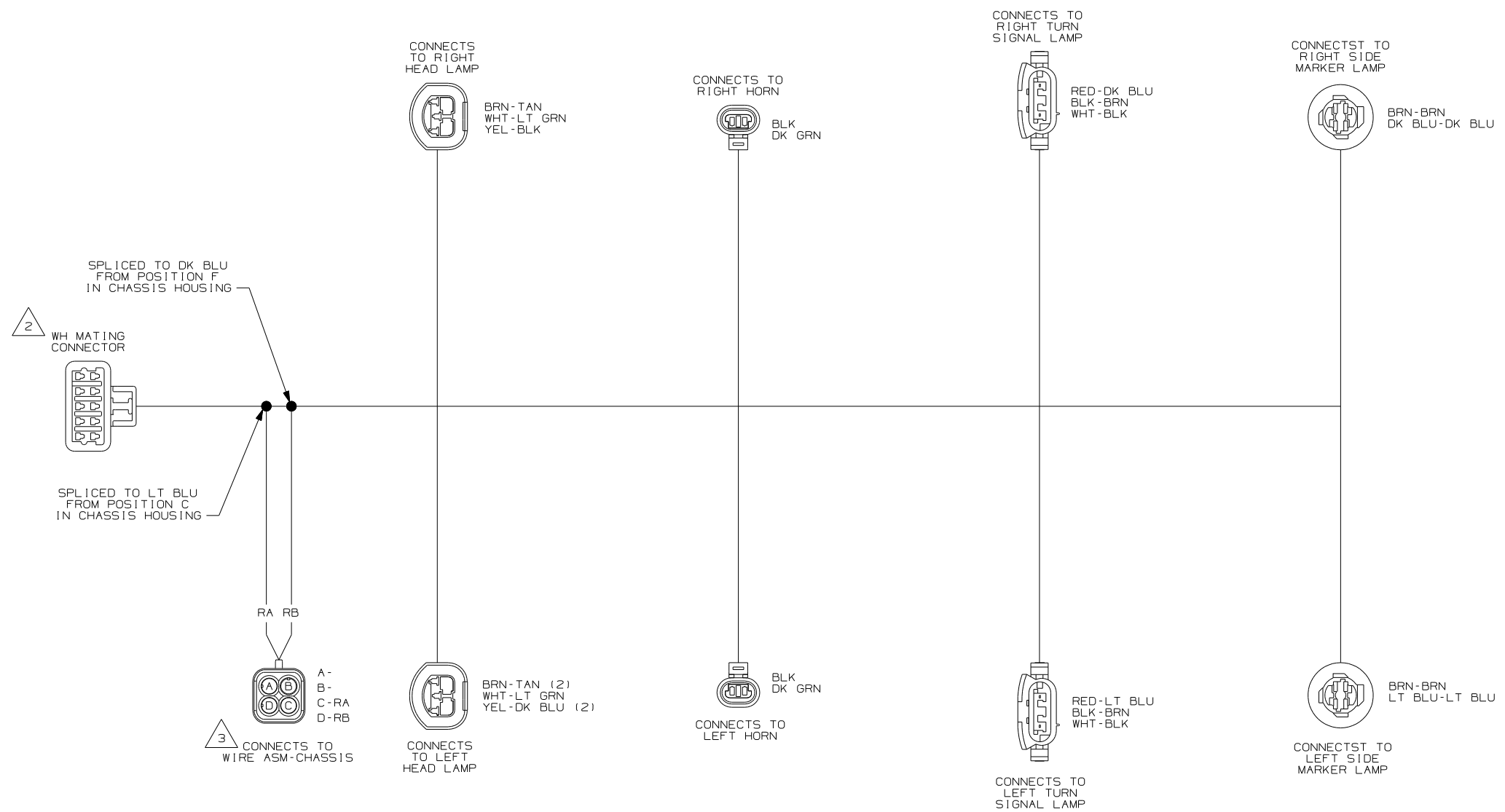

WIRING DIAGRAM-HEADLAMPS
(WIRE ASM 149398-08 REV-L)
(WORKHORSE CHASSIS)
(WINNEBAGO)

- 3 SEE WIRING DIAGRAM-BODY, 12V FOR ADDITIONAL INFORMATION.
- 2 SEE MANUFACTURERS DIAGRAM FOR ADDITIONAL INFORMATION.

1. SPLICES ARE THEORETICAL AND MAY DIFFER IN THE HARNESS.

NOTES:

FIRST USED	06 F-SER
TITLE:	DO NOT SCALE DRAWING
	WIRING DIAGRAM-AUTO LAMPS
SHEET 4	PART NO 152117

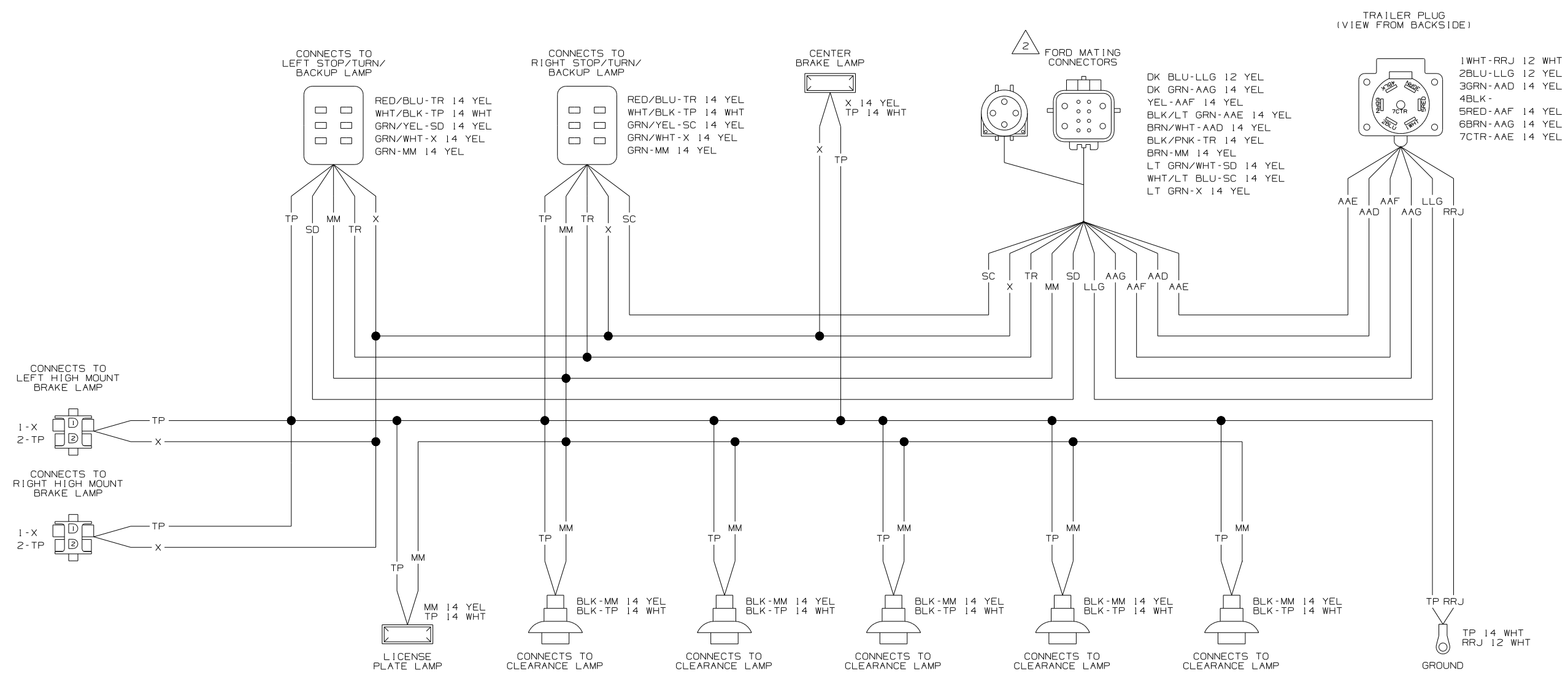

WIRING DIAGRAM-TAILLAMP,FD
(WIRE ASM 149622-03 REV-J)
(FORD CHASSIS)
(WINNEBAGO & ITASCA)

SEE MANUFACTURERS DIAGRAM FOR ADDITIONAL INFORMATION.

- 1. SPLICES ARE THEORETICAL AND MAY DIFFER IN THE HARNESS.

NOTES:

FIRST USED	06 F-SER
TITLE	DO NOT SCALE DRAWING
WIRING DIAGRAM-AUTO LAMPS	
SHEET 5	PART NO 152117

TRAILER PLUG
(VIEW FROM BACKSIDE)

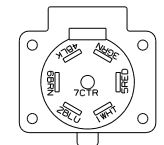

- 1WHT-RRJ 12 WHT
- 2BLU-
- 3GRN-MM 14 YEL
- 4BLK-
- 5RED-YELLOW
- 6BRN-GREEN
- 7CTR-TR 14 YEL

WH MATING CONNECTOR

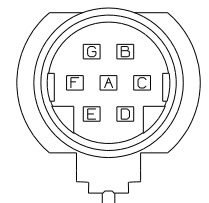

- A-AAN 14 YEL
- B-SD 14 YEL
- C-SC 14 YEL
- D-
- E-AAM 14 YEL
- F-MM 14 YEL
- G-TR 14 YEL

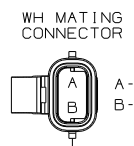
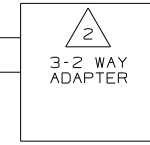

- A-X 14 YEL
- B-X 14 YEL

CENTER BRAKE LAMP



CONNECTS TO RIGHT STOP/TURN/BACKUP LAMP

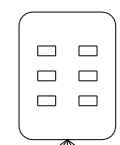

- RED/BLU-TR 14 YEL
- WHT/BLK-TP 14 WHT
- GRN/YEL-SC 14 YEL
- GRN/WHT-X 14 YEL
- GRN-AAM 14 YEL

CONNECTS TO LEFT STOP/TURN/BACKUP LAMP

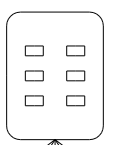

- RED/BLU-TR 14 YEL
- WHT/BLK-TP 14 WHT
- GRN/YEL-SD 14 YEL
- GRN/WHT-X 14 YEL
- GRN-AAN 14 YEL

CONNECTS TO LEFT HIGH MOUNT BRAKE LAMP

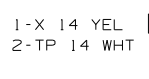

CONNECTS TO RIGHT HIGH MOUNT BRAKE LAMP

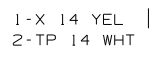

AAN TR SD TP X

X AAM TR TP

TP X

RRJ TR MM YEL GRN

WHT GRN YEL

SC AAM MM SD TR AAN

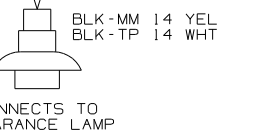
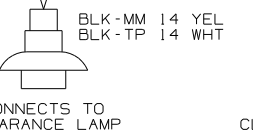
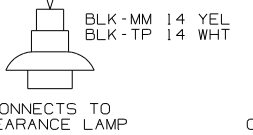
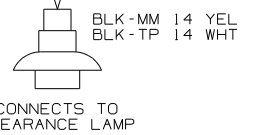
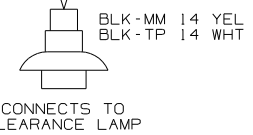
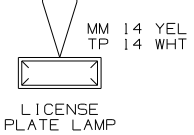
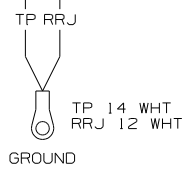

WIRING DIAGRAM-TAILLAMP,WH
(WIRE ASM 149622-04 REV-J)
(WORKHORSE CHASSIS)
(WINNEBAGO & ITASCA)

SEE MANUFACTURERS DIAGRAM FOR ADDITIONAL INFORMATION.

1. SPLICES ARE THEORETICAL AND MAY DIFFER IN THE HARNESS.

NOTES:

FIRST USED	06 F-SER
TITLE	DO NOT SCALE DRAWING
TITLE	WIRING DIAGRAM-AUTO LAMPS
SHEET 6	PART NO 152117