



DANGER

Danger of electrical shock, burns or death. Always remove all power sources before attempting any repair, service or diagnostic work. Power can be present from shore power, generator, inverter or battery. All power sources must be disabled and secured before performing any service.



CAUTION

If you lack the skills, tools or equipment to perform diagnostic or repair work leave such work to an authorized Winnebago Industries dealer or other qualified shop.

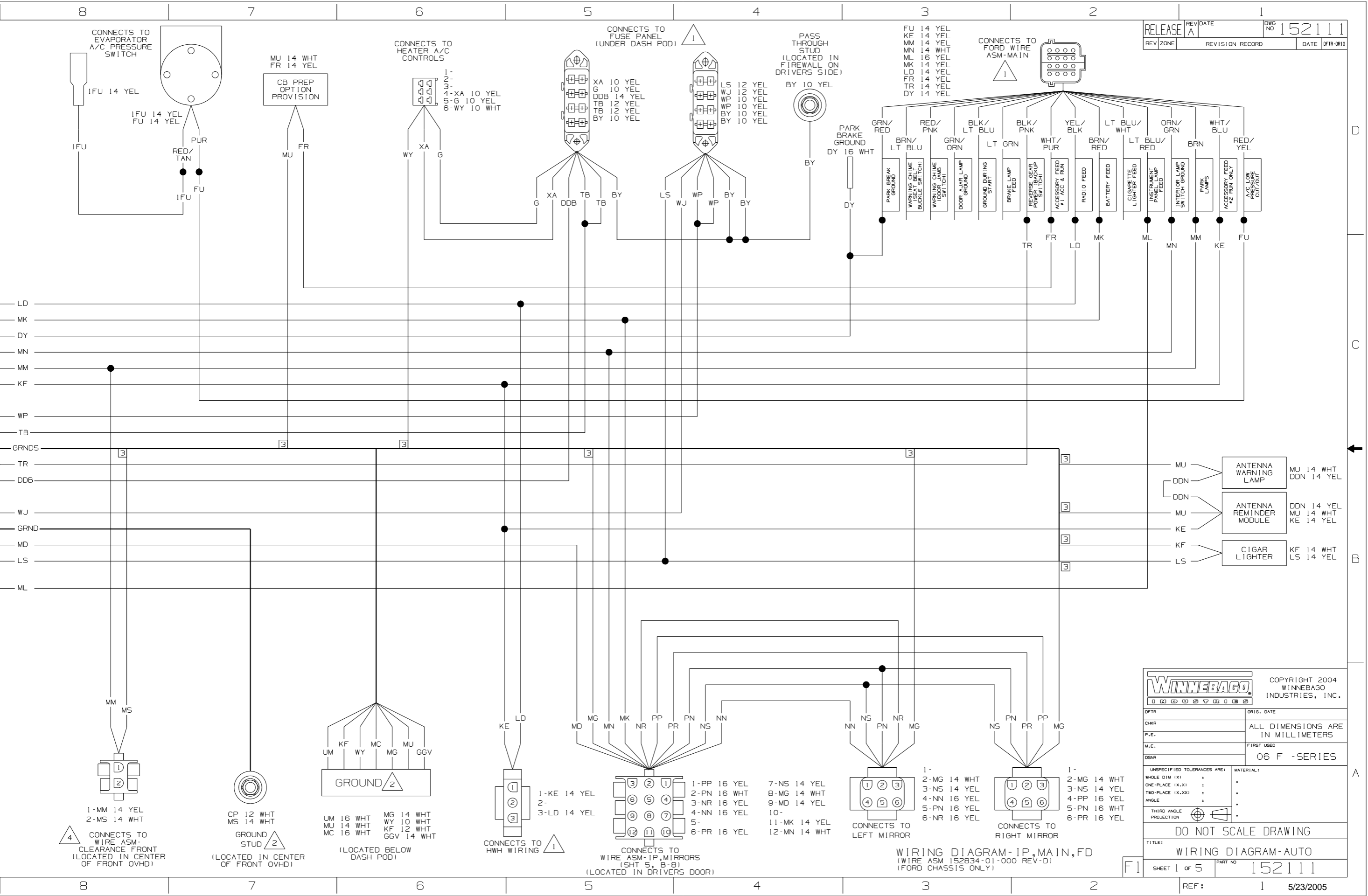

CONNECTS TO WIRE ASM - CLEARANCE FRONT (LOCATED IN CENTER OF FRONT OVHD)

GROUND STUD (LOCATED IN CENTER OF FRONT OVHD)

(LOCATED BELOW DASH POD)

CONNECTS TO HWH WIRING

CONNECTS TO WIRE ASM-IP, MIRRORS (SHT 5, B-8) (LOCATED IN DRIVERS DOOR)

CONNECTS TO LEFT MIRROR

CONNECTS TO RIGHT MIRROR

WIRING DIAGRAM-IP, MAIN, FD (WIRE ASM 152834-01-000 REV-D) (FORD CHASSIS ONLY)

WINNEBAGO COPYRIGHT 2004 WINNEBAGO INDUSTRIES, INC.

| | |
|------|-----------------------------------|
| DFTR | ORIG. DATE |
| CHR | ALL DIMENSIONS ARE IN MILLIMETERS |
| P.E. | |
| M.E. | FIRST USED |
| DSNR | 06 F - SERIES |

UNSPECIFIED TOLERANCES ARE: MATERIAL:

| | | |
|------------------------|---|--|
| WHOLE DIM (XX) | : | |
| ONE-PLACE (X.X) | : | |
| TWO-PLACE (X.XX) | : | |
| ANGLE | : | |
| THIRD ANGLE PROJECTION | | |

DO NOT SCALE DRAWING

TITLE: WIRING DIAGRAM-AUTO

SHEET 1 of 5 PART NO 152111

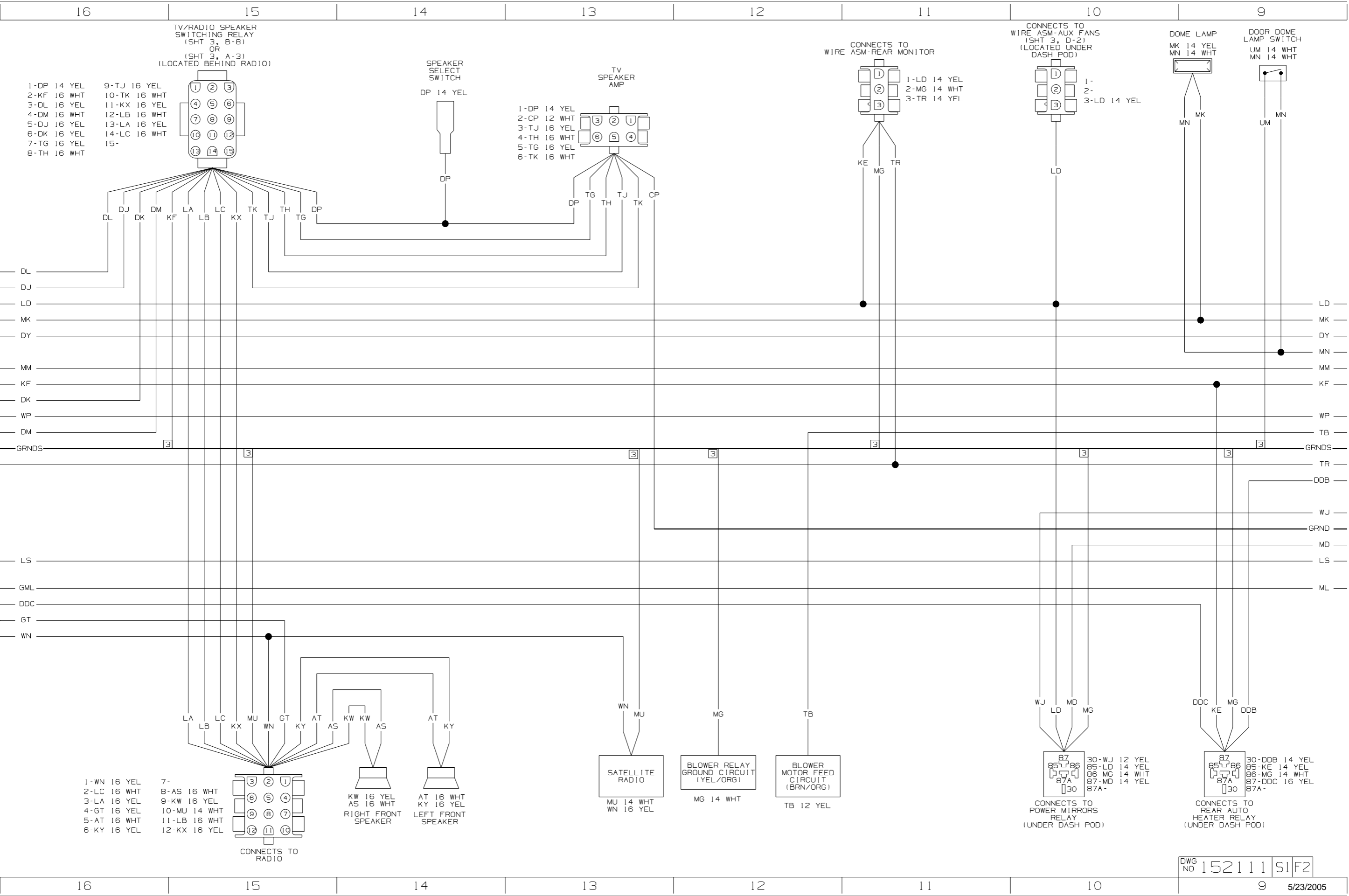

- A1-WP 10 YEL
- A2-KS 14 YEL
- A3-RA 14 YEL
- B1-DJ 16 YEL
- B2-DK 16 WHT
- B3-DL 16 YEL
- B4-DM 16 WHT
- C1-KE 14 YEL
- C2-DY 14 YEL
- D1-LL 16 WHT
- D2-LM 16 WHT
- D3-LN 16 WHT
- D4-LP 16 YEL
- E1-MM 14 YEL
- E2-BBN/DU 16 YEL
- F1-BBM/DR 16 YEL
- F2-KKK/GGD 16 YEL
- G1-DDA/GGE 16 YEL
- G2-CCY/GGF 16 YEL
- G3-LR 14 YEL
- G4-DS 14 YEL
- H1-KU 14 YEL
- H2-RB 14 YEL
- J1-
- J2-
- J3-
- J4-
- K1-
- K2-
- K3-

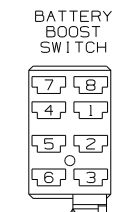
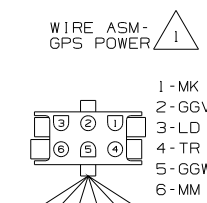
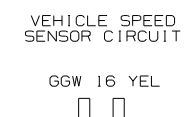
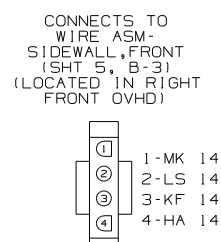
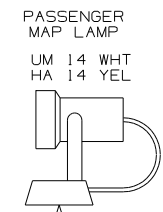
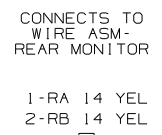
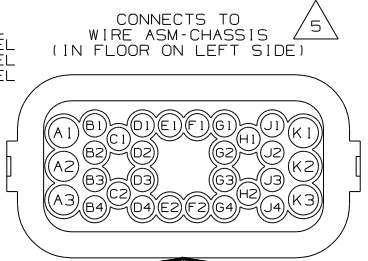

- 1-LS 12 YEL
- 2-LR 14 YEL
- 3-DDC 14 YEL
- 4-
- 5-
- 6-
- 7-
- 8-

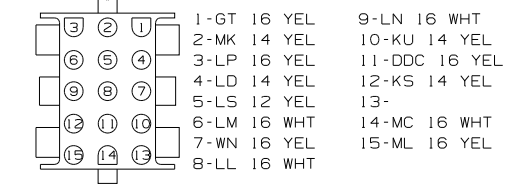
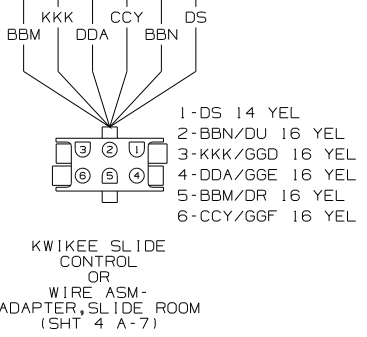
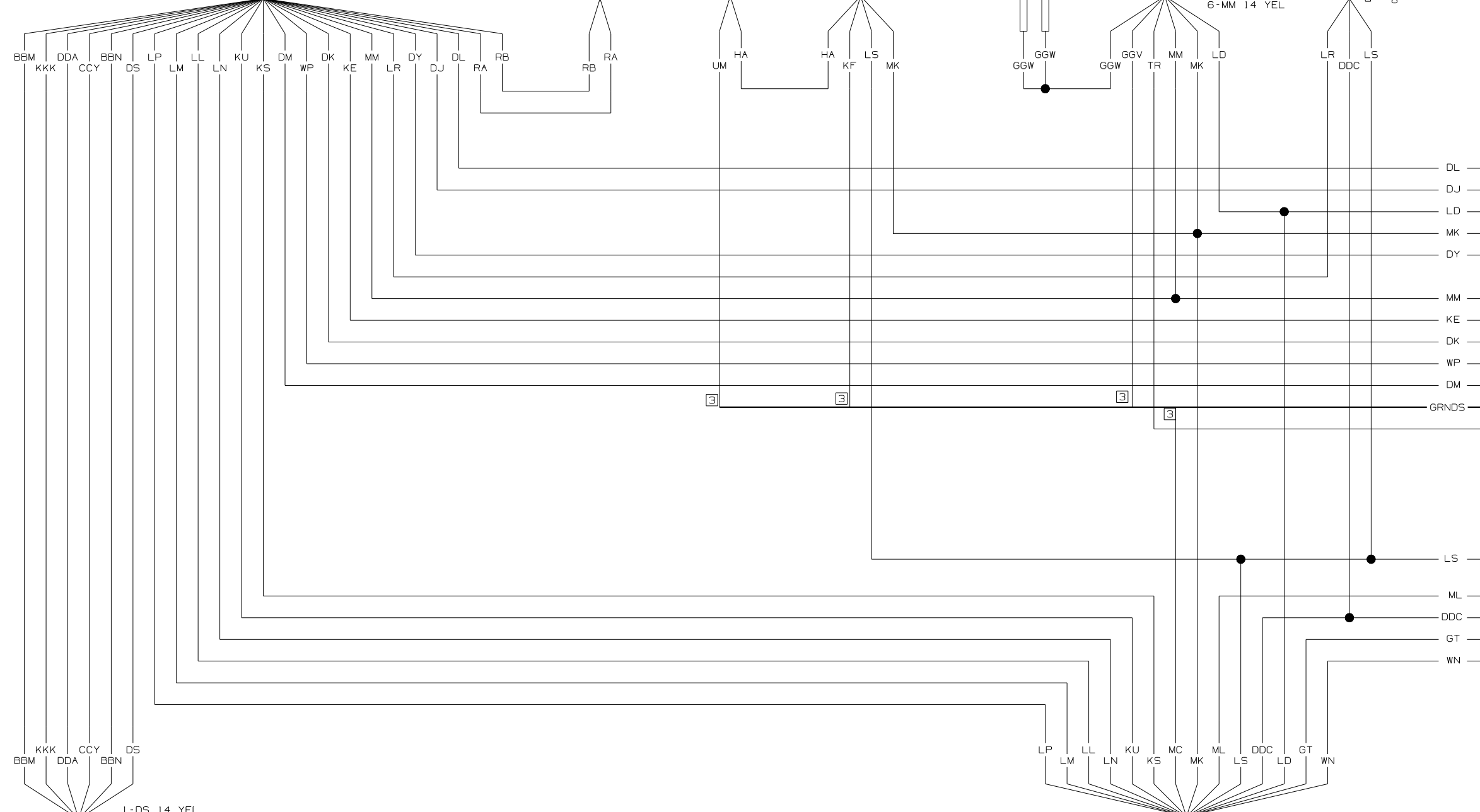

- NOTES:
- 5 SEE WIRING DIAGRAM-BODY, 12 FOR ADDITIONAL INFORMATION.
 - 4 SEE DIAGRAM-AUTO LAMPS FOR ADDITIONAL INFORMATION.
 - 3 NOT A SPLICE POINT. INDICATES ENTRY TO WIRE HARNESS.
 - 2 GROUNDS ARE SHOWN AS A SINGLE LINE FOR EASE IN TRACING. EACH GROUND WIRE IS SEPARATE FROM GROUND BARE OR STUD TO HOUSING OR DEVICES INCLUDED ON THAT PARTICULAR GROUND PATH.
 - 1 SEE MANUFACTURER'S DIAGRAM FOR ADDITIONAL INFORMATION.

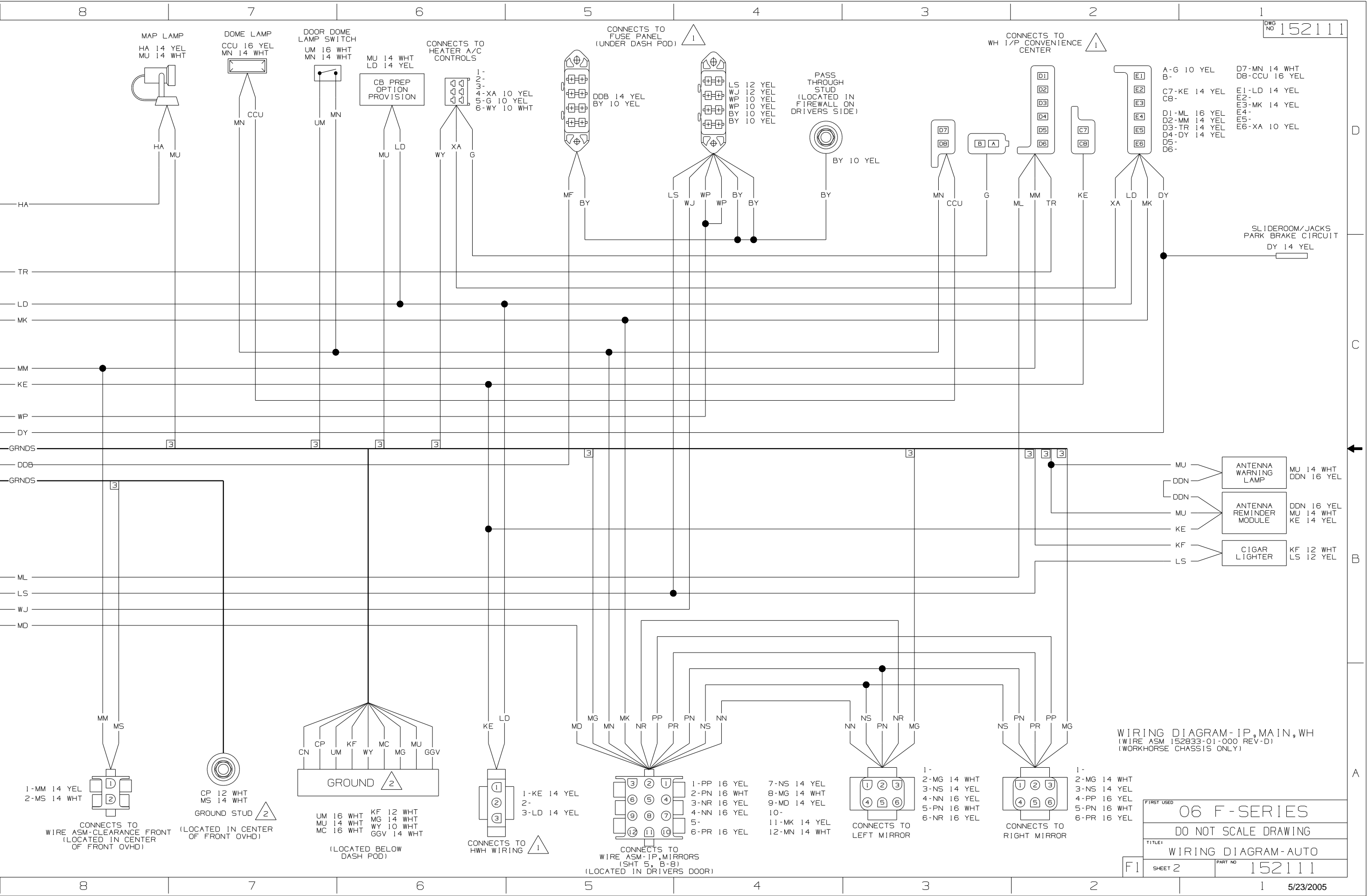

WIRING DIAGRAM-IP, MAIN, WH (WIRE ASM 152833-01-000 REV-D) (WORKHORSE CHASSIS ONLY)

| | | |
|------------|----------------------|--------|
| FIRST USED | 06 F-SERIES | |
| TITLE | DO NOT SCALE DRAWING | |
| | WIRING DIAGRAM-AUTO | |
| SHEET 2 | PART NO | 152111 |

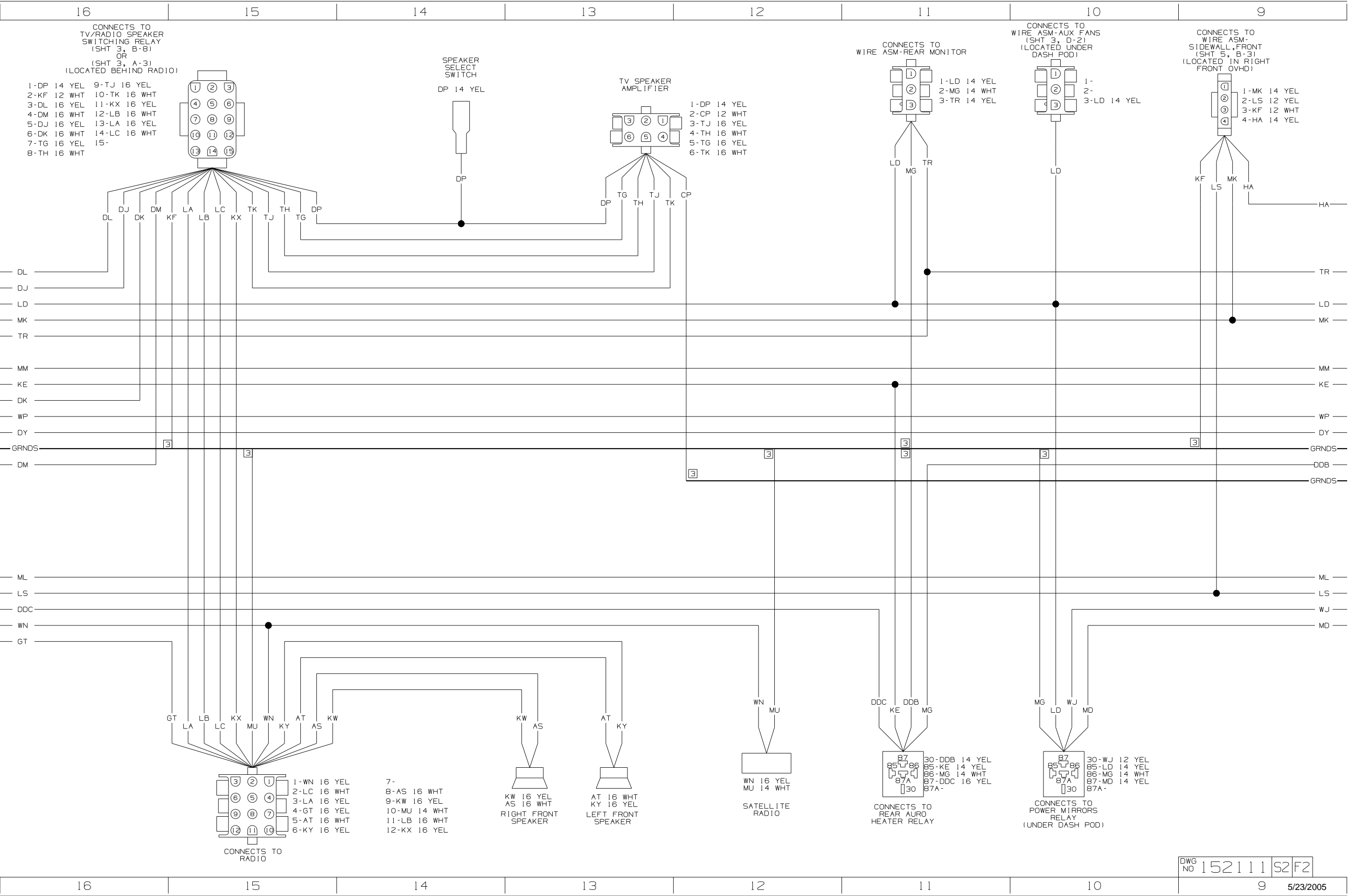

- A1-WP 10 YEL
- A2-KS 14 YEL
- A3-
- B1-DJ 16 YEL
- B2-DK 16 WHT
- B3-DL 16 YEL
- B4-DM 16 WHT
- C1-KE 14 YEL
- C2-DY 14 YEL
- D1-LL 16 WHT
- D2-LM 16 WHT
- D3-LN 16 WHT
- D4-LP 16 YEL
- E1-MM 14 YEL
- E2-BBN/DU 16 YEL
- F1-BBM/DR 16 YEL
- F2-KKK/GGD 16 YEL
- G1-DDA/GGE 16 YEL
- G2-CCY/GGF 16 YEL
- G3-LR 14 YEL
- G4-DS 14 YEL
- H1-KU 14 YEL
- H2-
- J1-
- J2-
- J3-
- J4-
- K1-
- K2-
- K3-

CONNECTS TO WIRE ASM-CHASSIS (1N FLOOR ON LEFT SIDE) 5

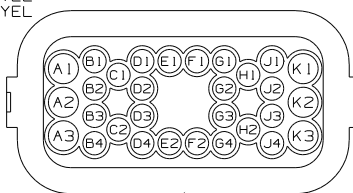

CONNECTS TO WIRE ASM-REAR MONITOR



VEHICLE SPEED SENSOR CIRCUIT

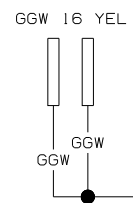

WIRE ASM-GPS POWER 1

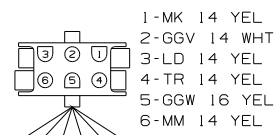

BATTERY BOOST SWITCH

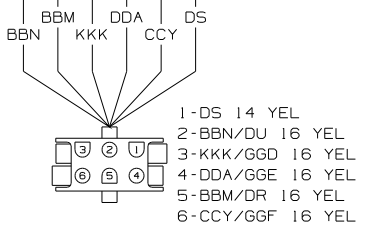
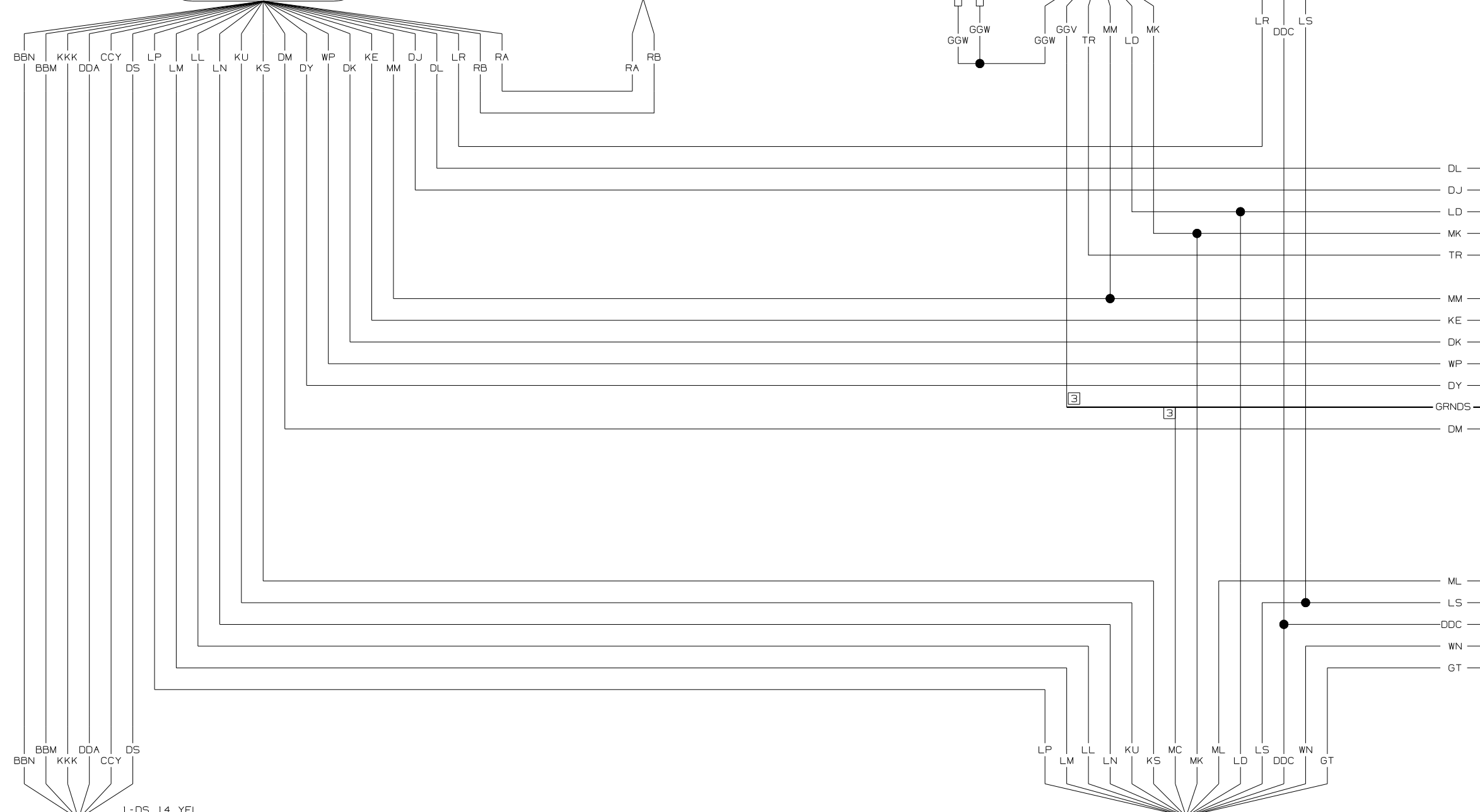
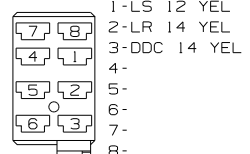

KWIKEE SLIDE CONTROL OR WIRE ASM-ADAPTER, SLIDE ROOM (SHT 4 A-7) (LOCATED BELOW DASH POD)



CONNECTS TO WIRE ASM-IP, POD (SHT 3, C-8) (LOCATED UNDER DASH POD)

- NOTES:
- 5 SEE WIRING DIAGRAM-BODY, 12V FOR ADDITIONAL INFORMATION.
 - 4 SEE WIRING DIAGRAM-AUTO LAMPS FOR ADDITIONAL INFORMATION.
 - 3 NOT A SPLICE POINT. INDICATES ENTRY TO WIRE HARNESS.
 - 2 GROUNDS ARE SHOWN AS A SINGLE LINE FOR EASE IN TRACING. EACH GROUND WIRE IS SEPARATE FROM GROUND BARE OR STUD TO HOUSING OR DEVICES INCLUDED ON THAT PARTICULAR GROUND PATH.
 - 1 SEE MANUFACTURER'S DIAGRAM FOR ADDITIONAL INFORMATION.

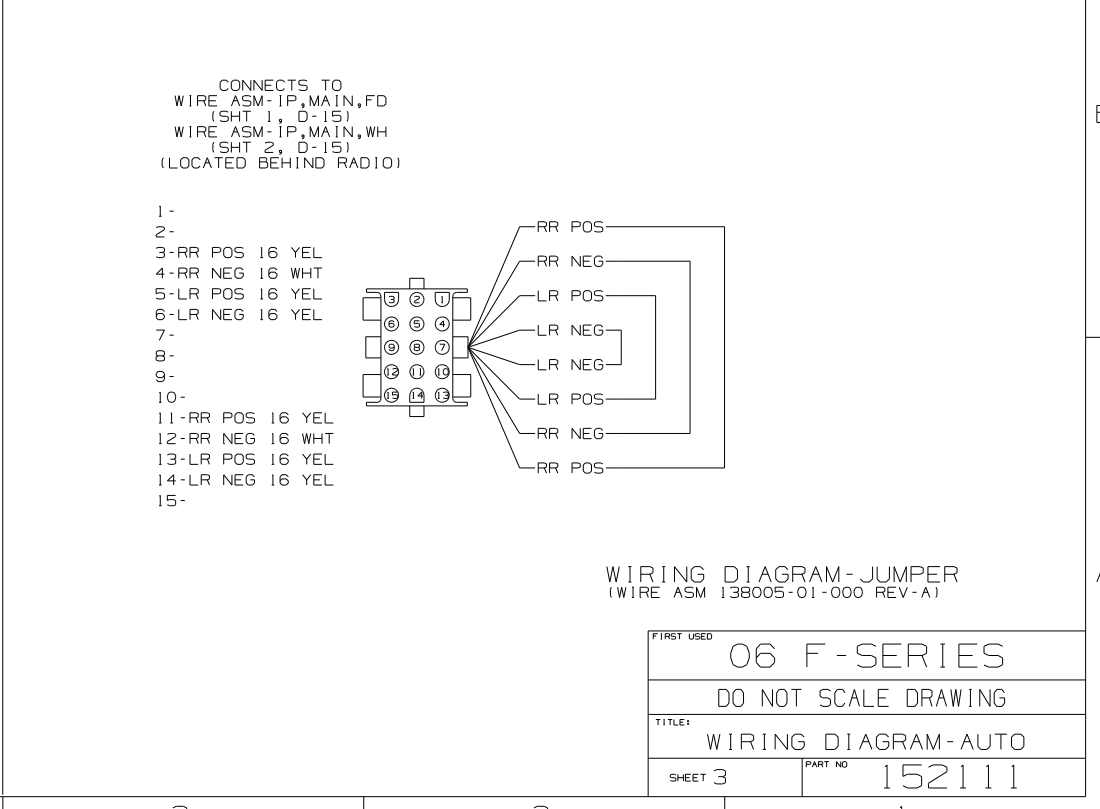
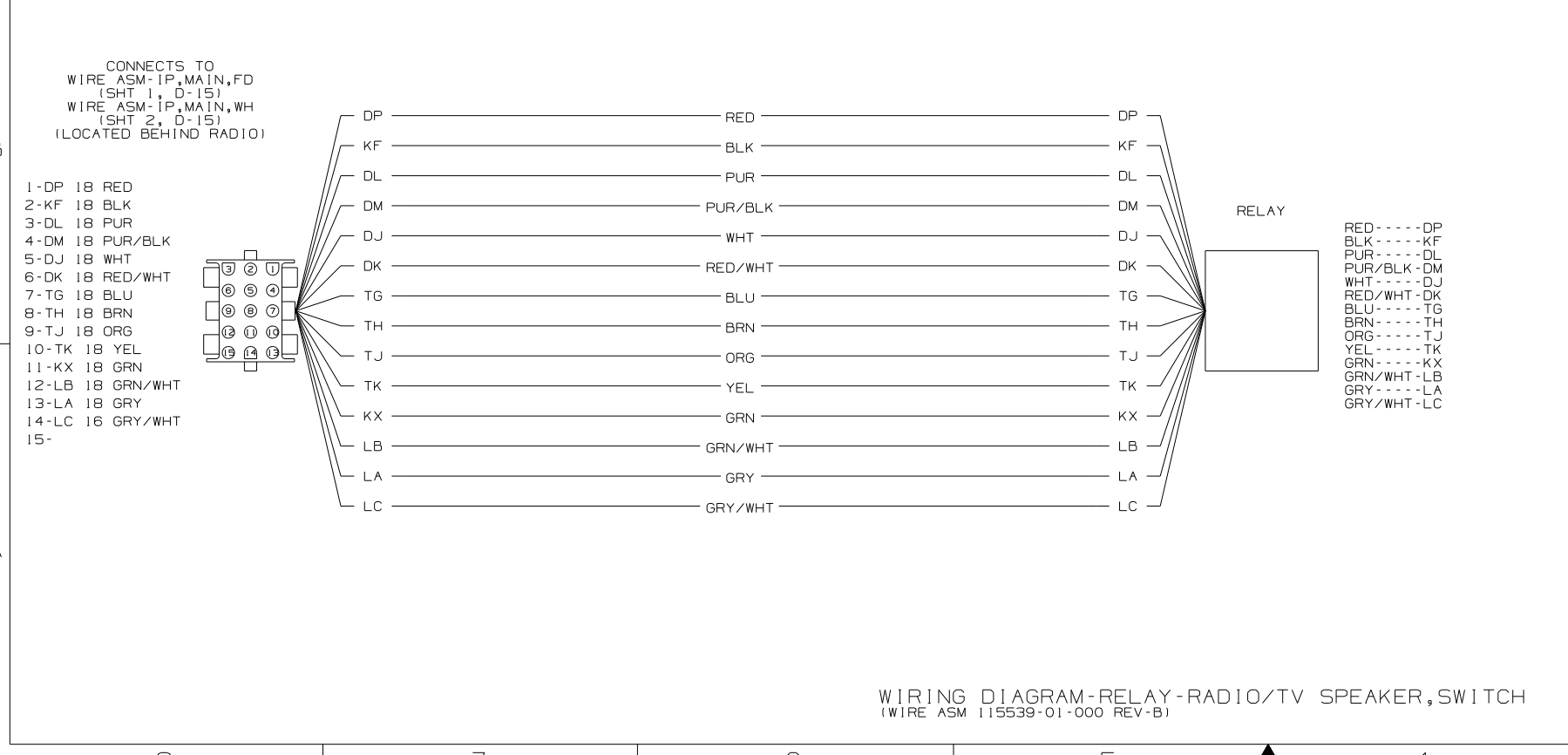
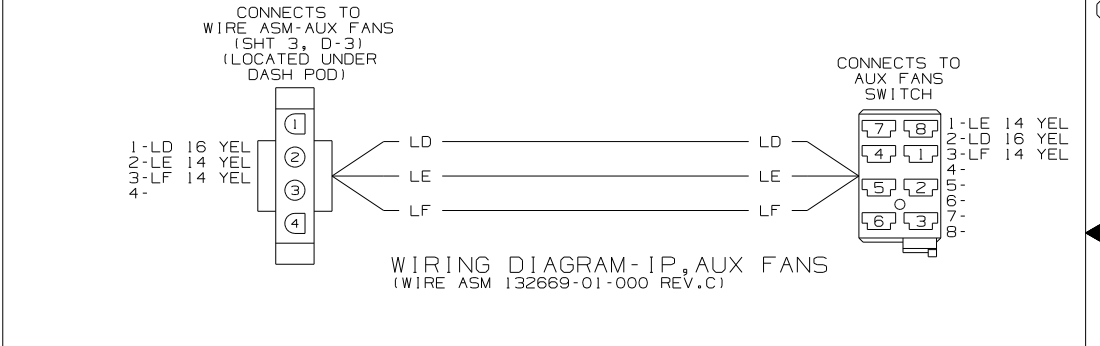
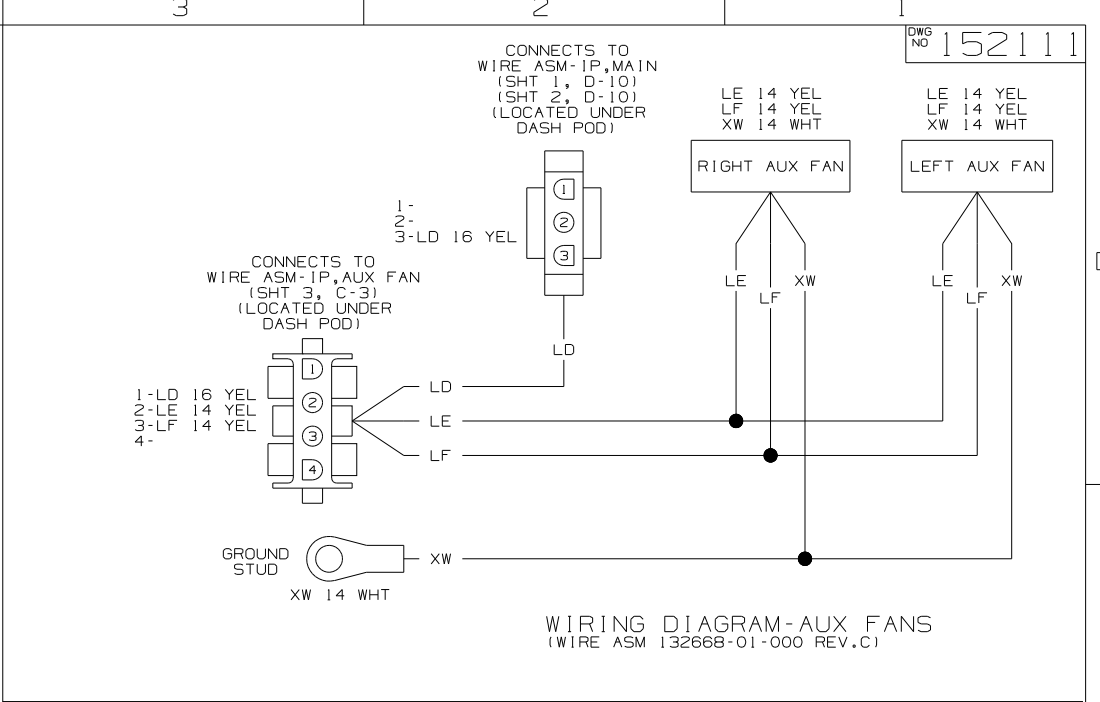
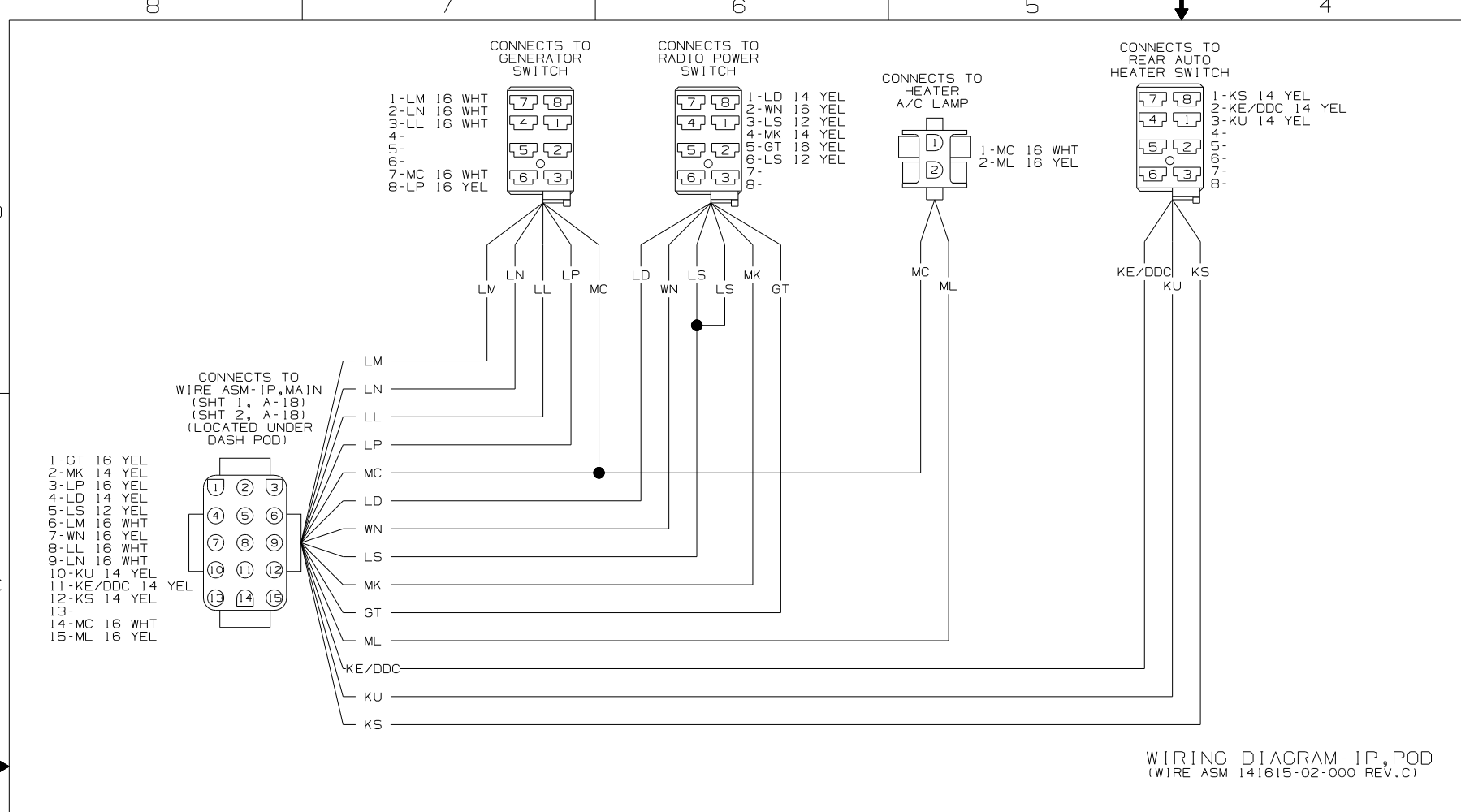

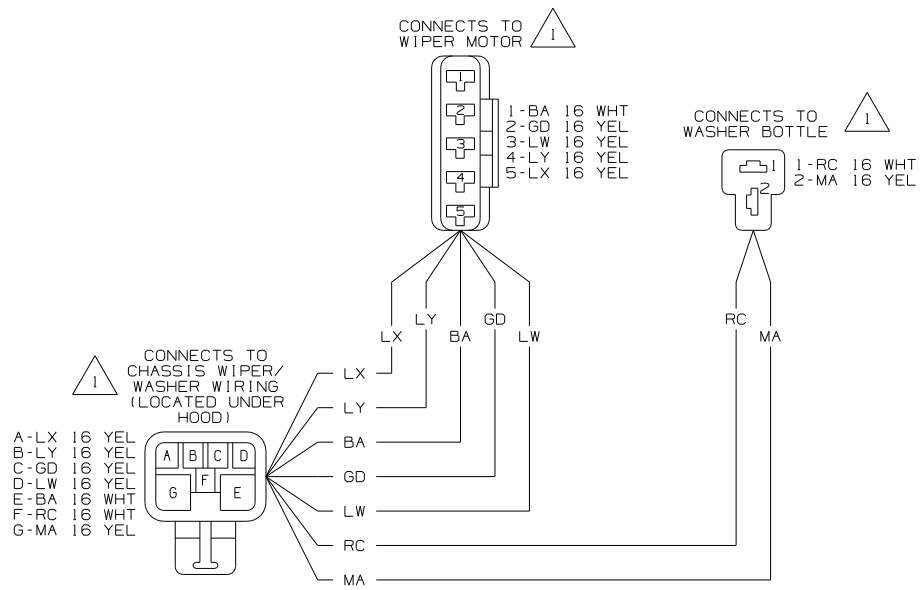

WIRING DIAGRAM-WIPER/WASHER
(WIRE ASM 126030-01-000 REV-D)
(WORKHORSE 22,000#)
(WORKHORSE 20,700#)

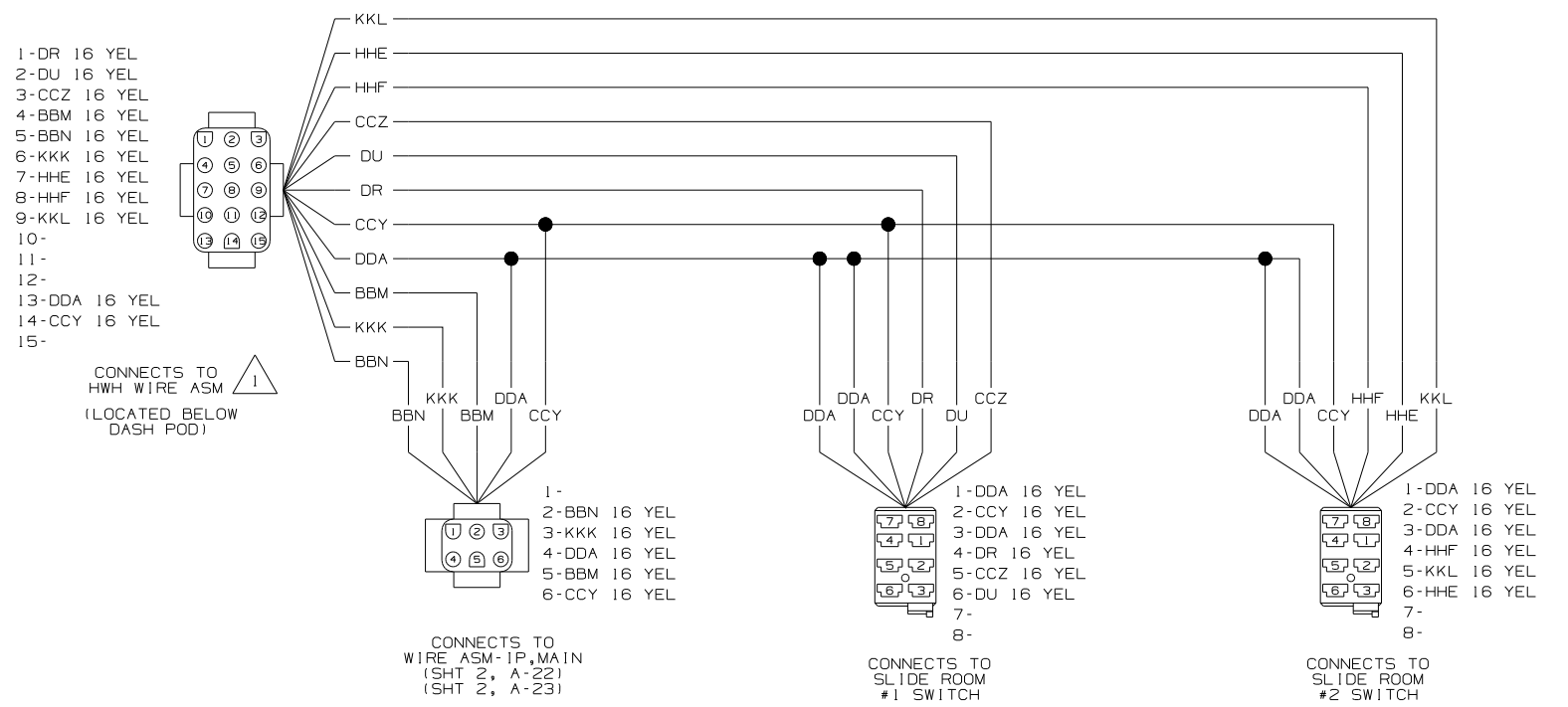
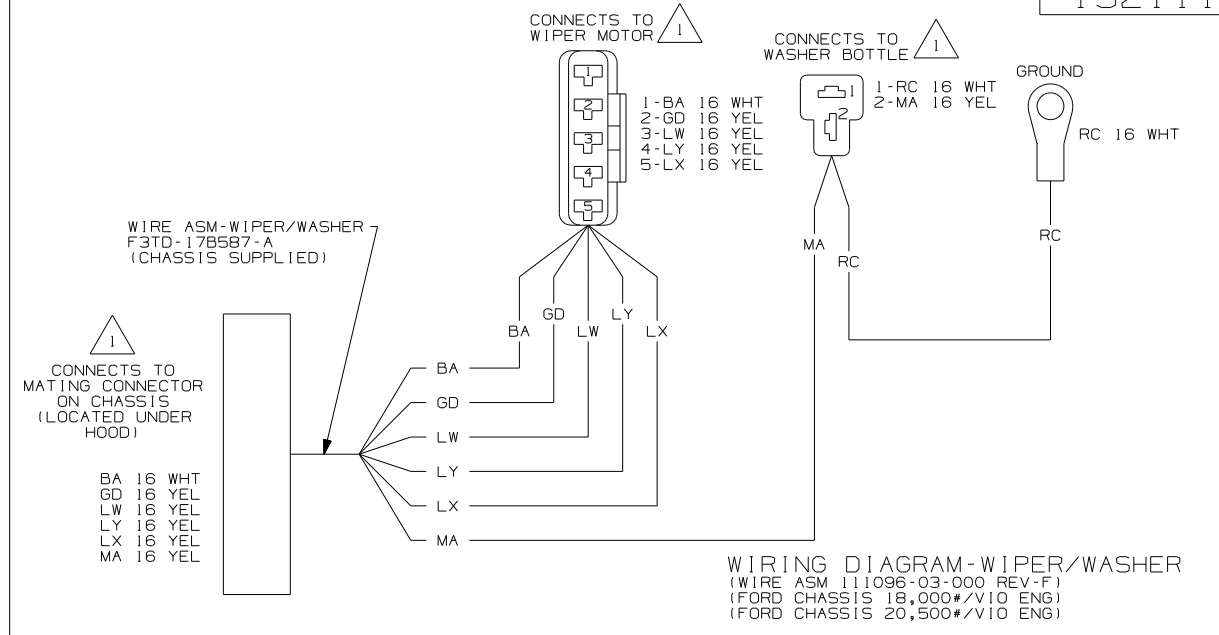

WIRING DIAGRAM-ADAPTER, SLIDEROOM
WIRE ASM-149554 REV-C

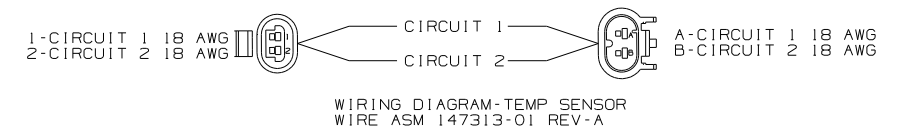
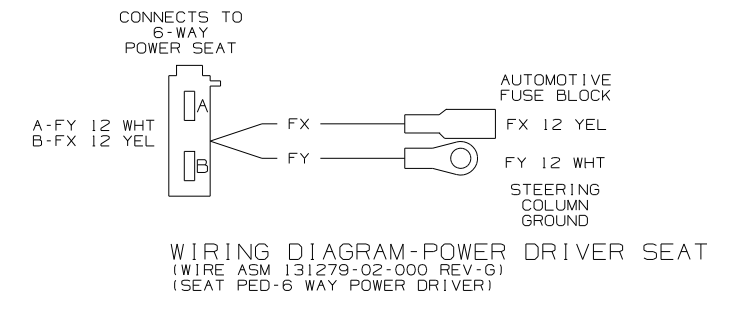

| | |
|------------|----------------------|
| FIRST USED | 06 F-SERIES |
| TITLE | DO NOT SCALE DRAWING |
| SHEET 4 | WIRING DIAGRAM-AUTO |
| PART NO | 152111 |

NOTES:
1 SEE MANUFACTURER'S DIAGRAM FOR ADDITIONAL INFORMATION.

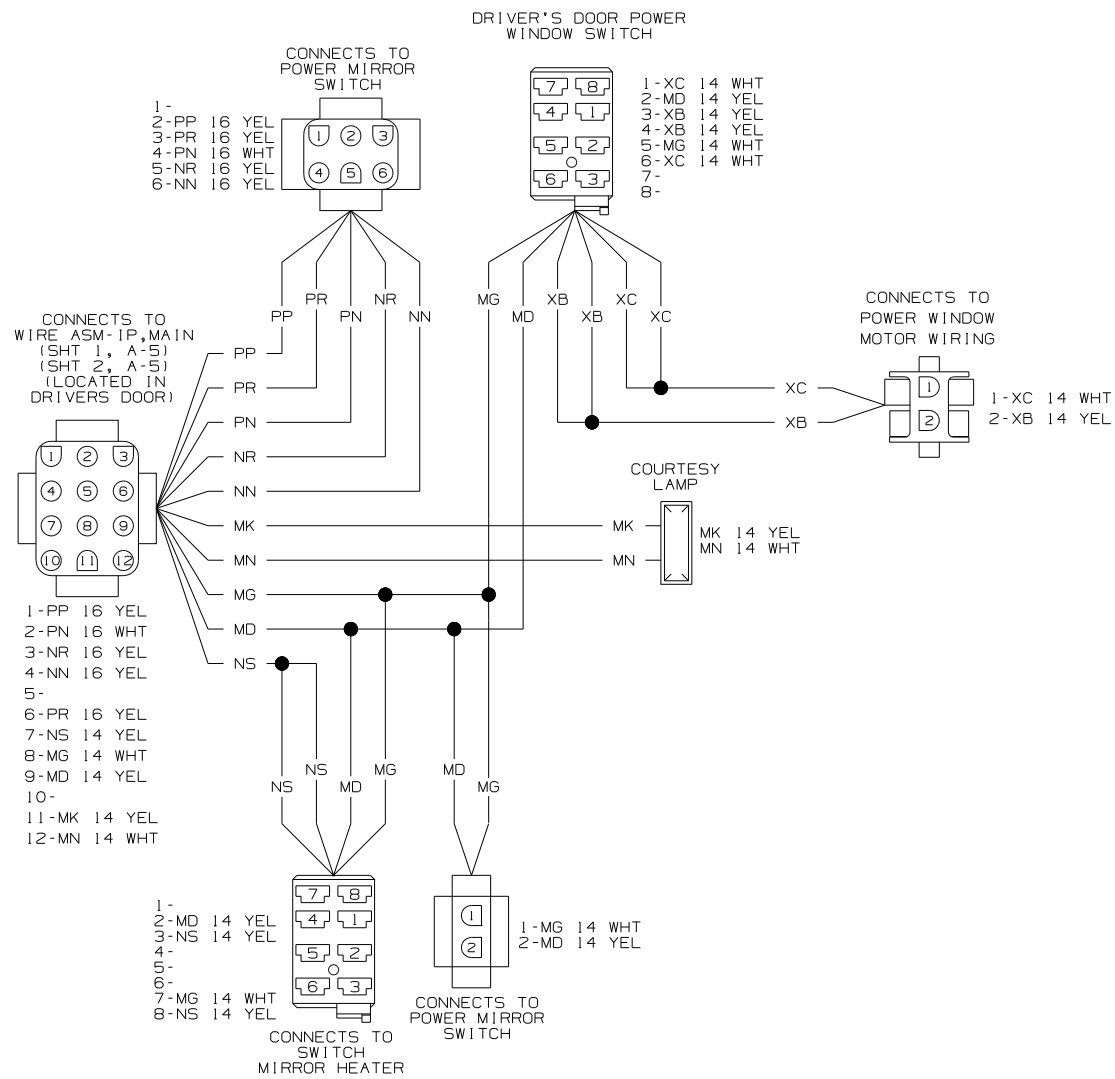

WIRING DIAGRAM-IP POWER,MIRROR
(WIRE ASM 129436-09-000 REV.X)
(F-SERIES)

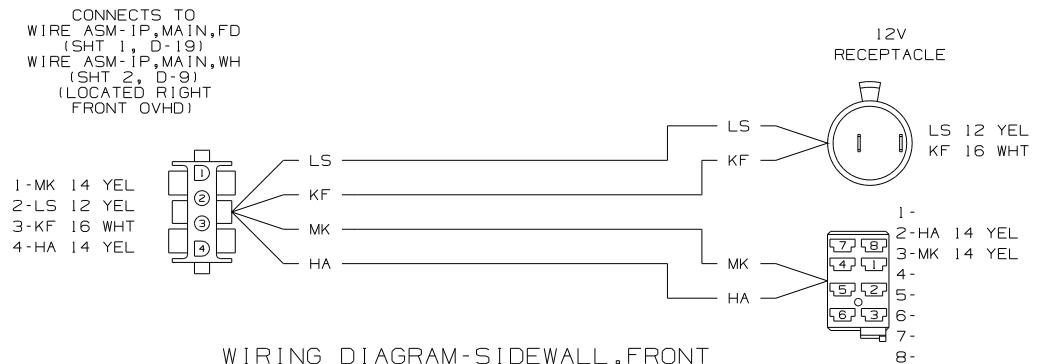

WIRING DIAGRAM-SIDEWALL,FRONT
(WIRE ASM 143287-02-000 REV-A)

| | |
|----------------------|----------------|
| FIRST USED | |
| 06 F - SERIES | |
| DO NOT SCALE DRAWING | |
| TITLE: | |
| WIRING DIAGRAM-AUTO | |
| SHEET 5 | PART NO 152111 |