



DANGER

Danger of electrical shock, burns or death. Always remove all power sources before attempting any repair, service or diagnostic work. Power can be present from shore power, generator, inverter or battery. All power sources must be disabled and secured before performing any service.



CAUTION

If you lack the skills, tools or equipment to perform diagnostic or repair work leave such work to an authorized Winnebago Industries dealer or other qualified shop.

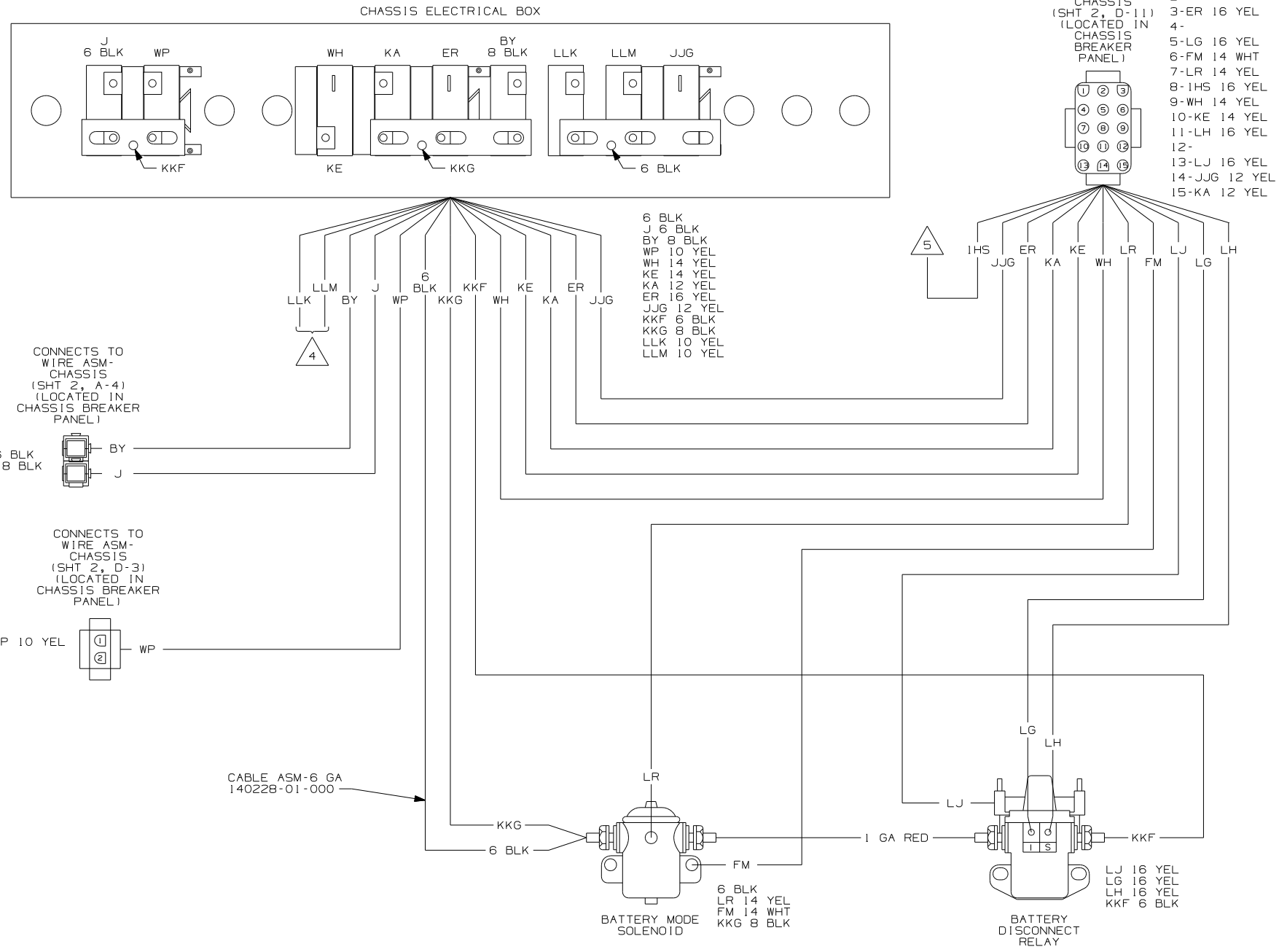

- 5 CIRCUIT IS NOT USED.
- 4 WIRE IS FROM WIRE ASM-SLIDEOUT POWER.
- 3 SEE WIRING DIAGRAM-AUTO FOR ADDITIONAL INFORMATION.
- 2 SEE MANUFACTURERS DIAGRAM FOR ADDITIONAL INFORMATION.

1. SPLICES ARE THEORETICAL AND MAY DIFFER IN THE HARNESS.

WIRING DIAGRAM-ELECTRICAL BOX
(WIRE ASM 124125-03 REV-L)

WINNEBAGO		COPYRIGHT 2004 WINNEBAGO INDUSTRIES, INC.	
DFT#	ORIG. DATE	ALL DIMENSIONS ARE IN MILLIMETERS	
CHKR			
P.E.			
M.E.	FIRST USED	06 D29R	
DSNR			
UNSPECIFIED TOLERANCES ARE:		MATERIAL:	
WHOLE DIM (X)	:		
ONE-PLACE (X.X)	:		
TWO-PLACE (X.XX)	:		
ANGLE	:		
THIRD ANGLE PROJECTION			
DO NOT SCALE DRAWING			
TITLE: WIRING DIAGRAM-BODY, 12V			
SHEET 1 of 7	PART NO	153527	
REF:		1 5/9/2005	

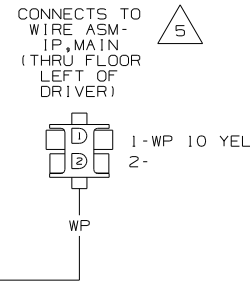
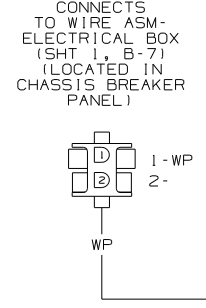
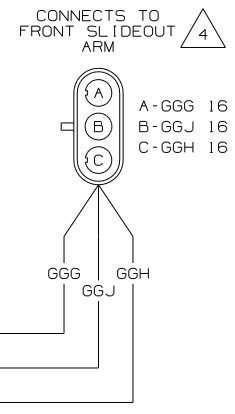
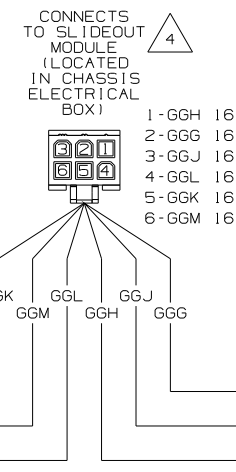
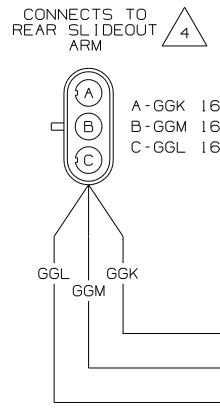
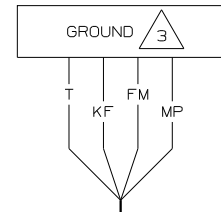

GND

DY

WE
WC

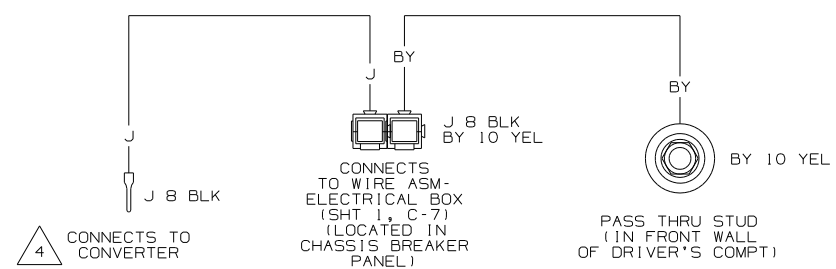
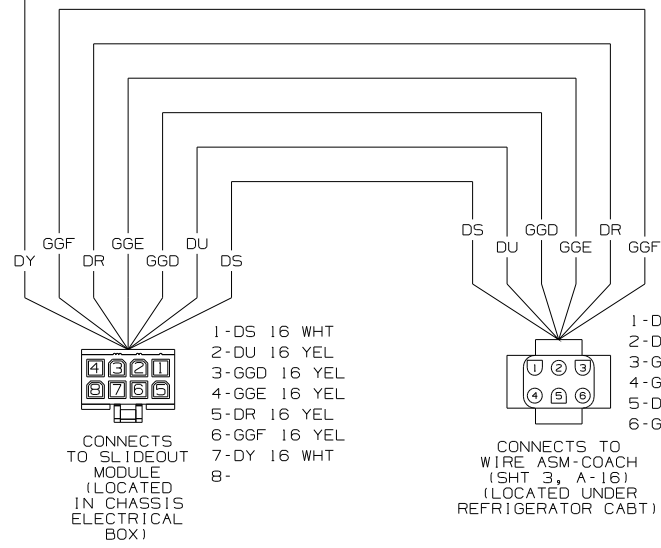
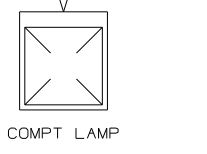

WIRING DIAGRAM-CHASSIS (WIRE ASM 153525 REV-B)

FIRST USED	06 D29R	
TITLE	DO NOT SCALE DRAWING	
	WIRING DIAGRAM-BODY, 12V	
SHEET 2	PART NO	153527

F1

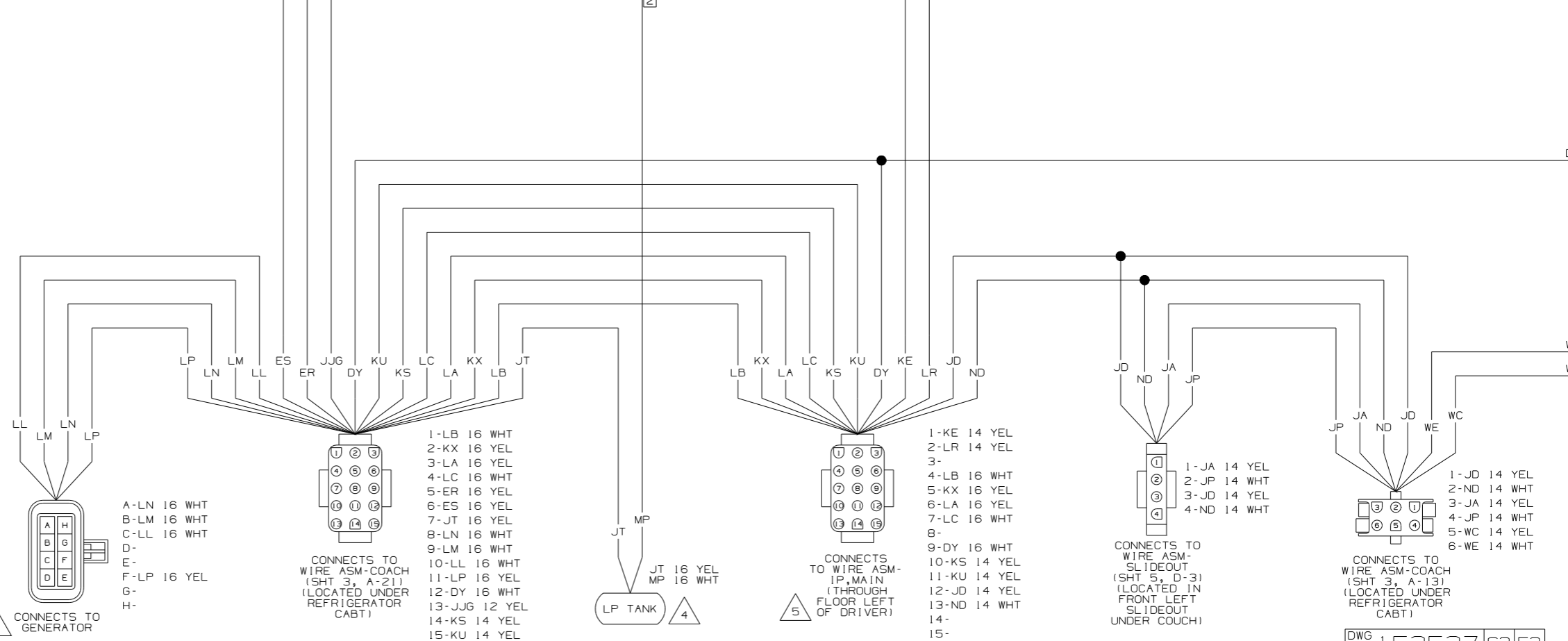
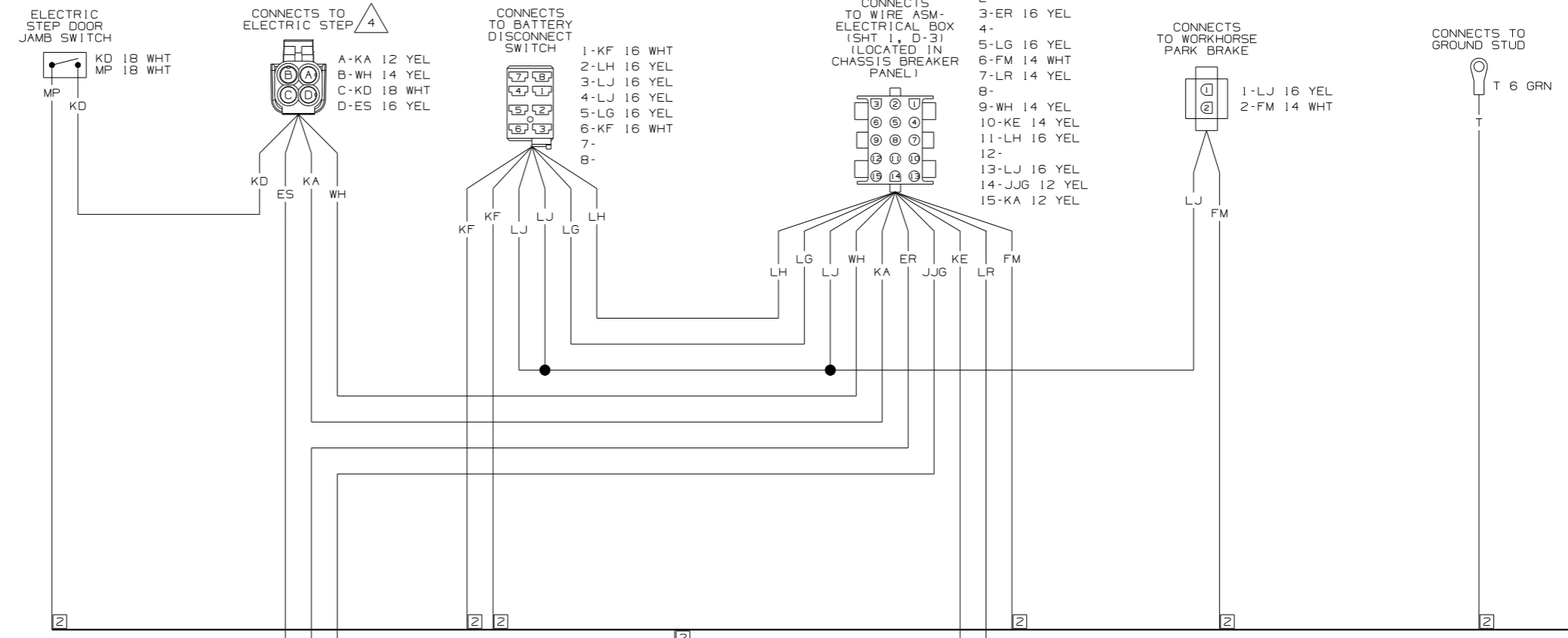

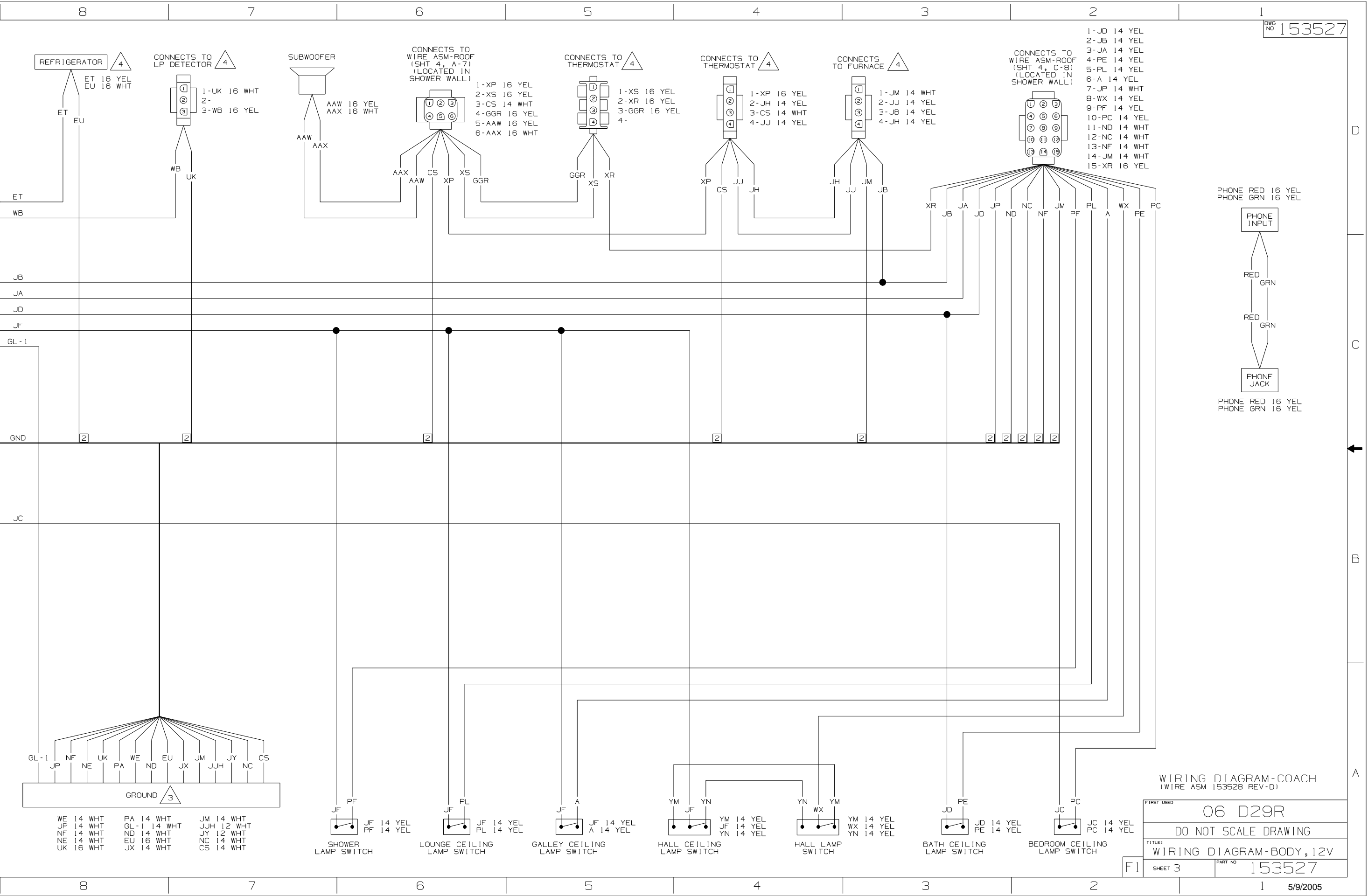

REFRIGERATOR 4

CONNECTS TO LP DETECTOR 4

SUBWOOFER

CONNECTS TO WIRE ASM-ROOF (SHT 4, A-7) (LOCATED IN SHOWER WALL)

CONNECTS TO THERMOSTAT 4

CONNECTS TO THERMOSTAT 4

CONNECTS TO FURNACE 4

CONNECTS TO WIRE ASM-ROOF (SHT 4, C-8) (LOCATED IN SHOWER WALL)

PHONE RED 16 YEL
PHONE GRN 16 YEL

PHONE INPUT

RED GRN

RED GRN

PHONE JACK

PHONE RED 16 YEL
PHONE GRN 16 YEL

WIRING DIAGRAM-COACH
(WIRE ASM 153528 REV-D)

FIRST USED	06 D29R
DO NOT SCALE DRAWING	
TITLE	WIRING DIAGRAM-BODY, 12V
SHEET 3	PART NO 153527

- WE 14 WHT
- JP 14 WHT
- NF 14 WHT
- NE 14 WHT
- UK 16 WHT
- PA 14 WHT
- GL-1 14 WHT
- ND 14 WHT
- EU 16 WHT
- JX 14 WHT
- JM 14 WHT
- JJH 12 WHT
- JY 12 WHT
- NC 14 WHT
- CS 14 WHT

SHOWER LAMP SWITCH

LOUNGE CEILING LAMP SWITCH

GALLEY CEILING LAMP SWITCH

HALL CEILING LAMP SWITCH

HALL LAMP SWITCH

BATH CEILING LAMP SWITCH

BEDROOM CEILING LAMP SWITCH

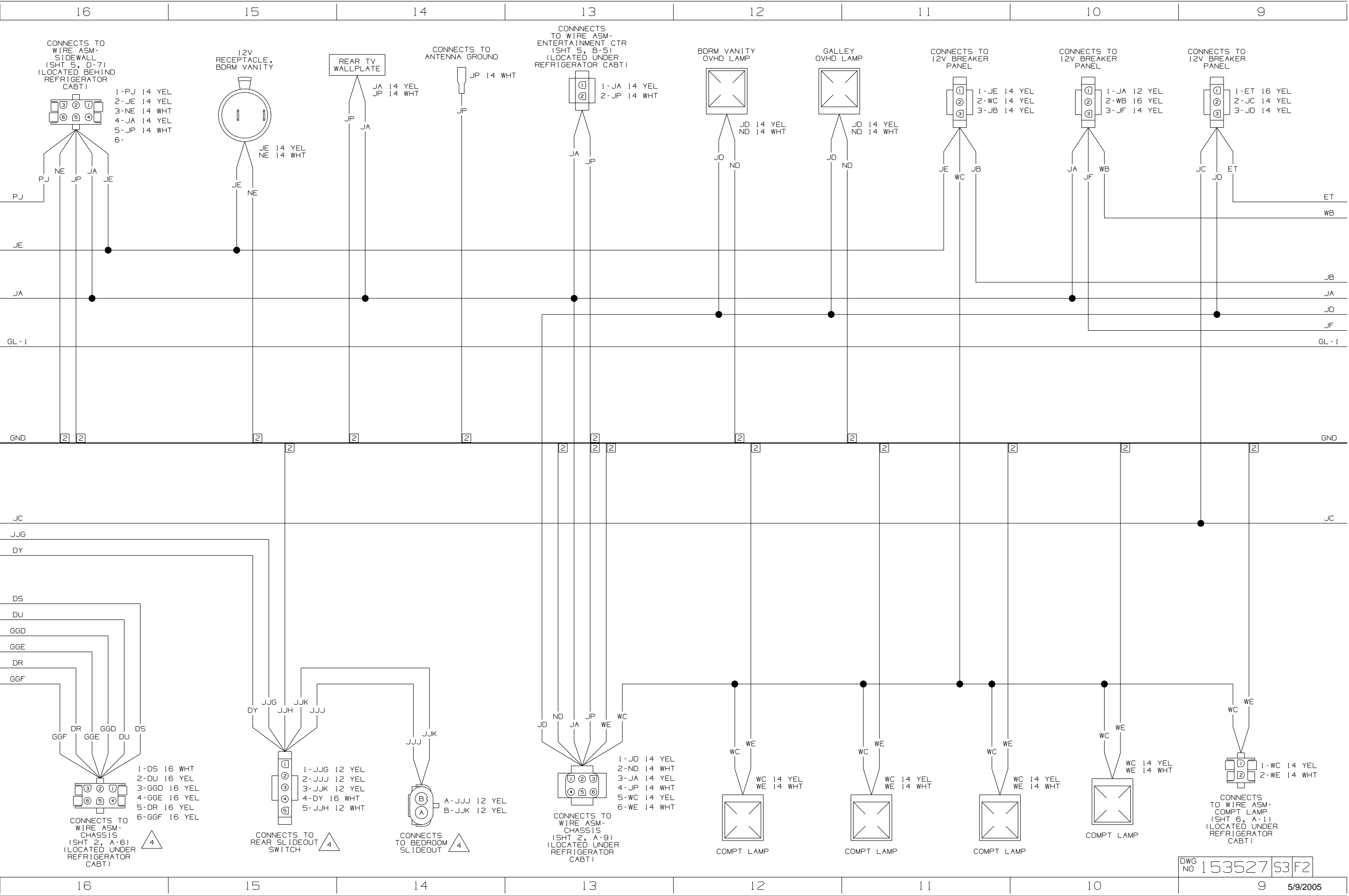

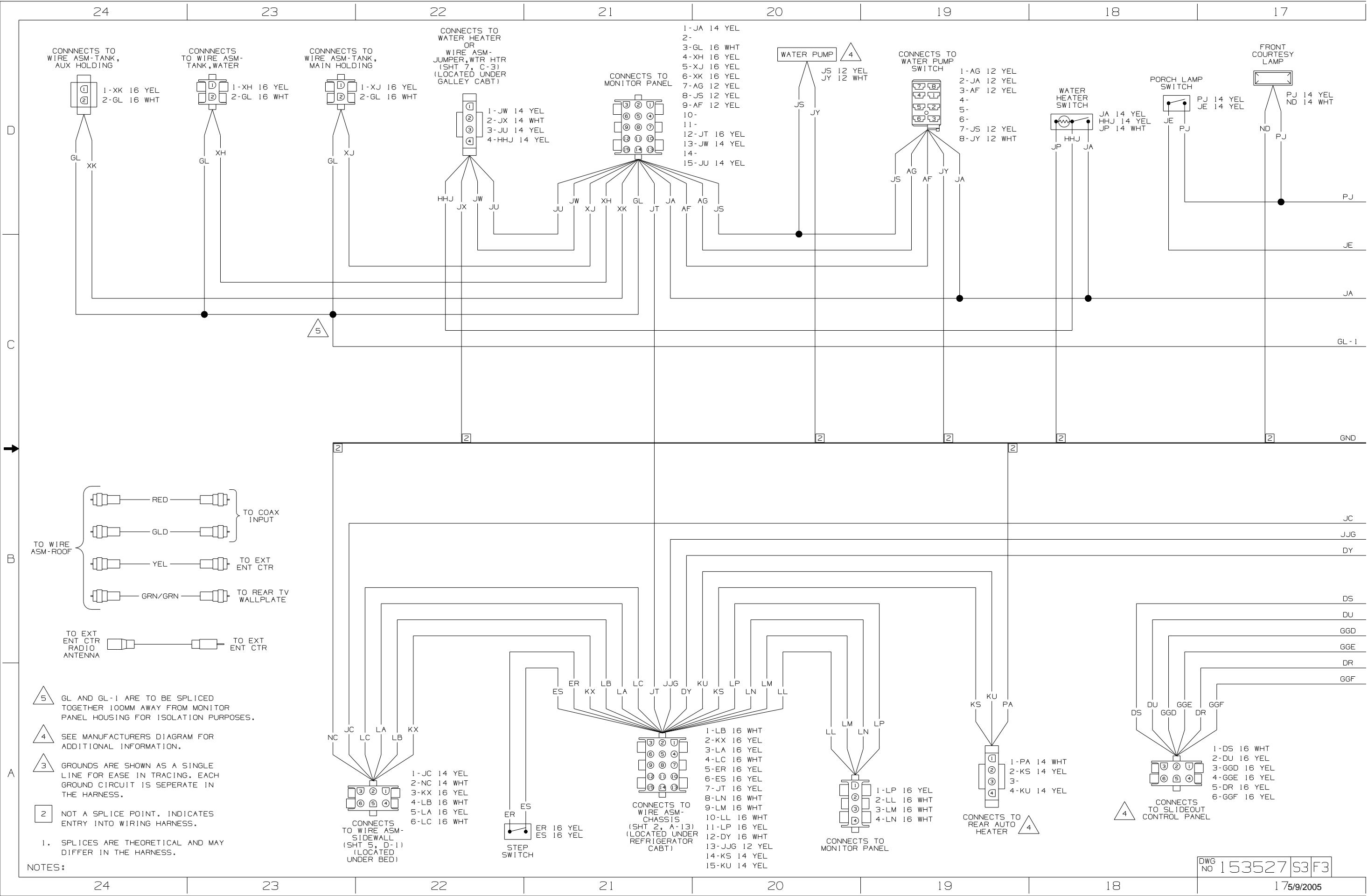

CONNECTS TO WIRE ASM-TANK, AUX HOLDING

1-XK 16 YEL
2-GL 16 WHT

CONNECTS TO WIRE ASM-TANK, WATER

1-XH 16 YEL
2-GL 16 WHT

CONNECTS TO WIRE ASM-TANK, MAIN HOLDING

1-XJ 16 YEL
2-GL 16 WHT

CONNECTS TO WATER HEATER OR WIRE ASM-JUMPER, WTR HTR (SHT 7, C-3) (LOCATED UNDER GALLEY CABT)

1-JW 14 YEL
2-JX 14 WHT
3-JU 14 YEL
4-HHJ 14 YEL

CONNECTS TO MONITOR PANEL

1-JA 14 YEL
2-
3-GL 16 WHT
4-XH 16 YEL
5-XJ 16 YEL
6-XK 16 YEL
7-AG 12 YEL
8-JS 12 YEL
9-AF 12 YEL
10-
11-
12-JT 16 YEL
13-JW 14 YEL
14-
15-JU 14 YEL

WATER PUMP

JS 12 YEL
JY 12 WHT

CONNECTS TO WATER PUMP SWITCH

1-AG 12 YEL
2-JA 12 YEL
3-AF 12 YEL
4-
5-
6-
7-JS 12 YEL
8-JY 12 WHT

WATER HEATER SWITCH

JA 14 YEL
HHJ 14 YEL
JP 14 WHT

PORCH LAMP SWITCH

PJ 14 YEL
JE 14 YEL

FRONT COURTESY LAMP

PJ 14 YEL
ND 14 WHT

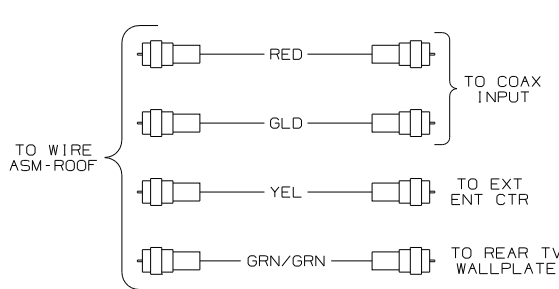

- 5 GL AND GL-1 ARE TO BE SPLICED TOGETHER 100MM AWAY FROM MONITOR PANEL HOUSING FOR ISOLATION PURPOSES.
- 4 SEE MANUFACTURERS DIAGRAM FOR ADDITIONAL INFORMATION.
- 3 GROUNDS ARE SHOWN AS A SINGLE LINE FOR EASE IN TRACING. EACH GROUND CIRCUIT IS SEPERATE IN THE HARNESS.
- 2 NOT A SPLICE POINT. INDICATES ENTRY INTO WIRING HARNESS.
1. SPLICES ARE THEORETICAL AND MAY DIFFER IN THE HARNESS.

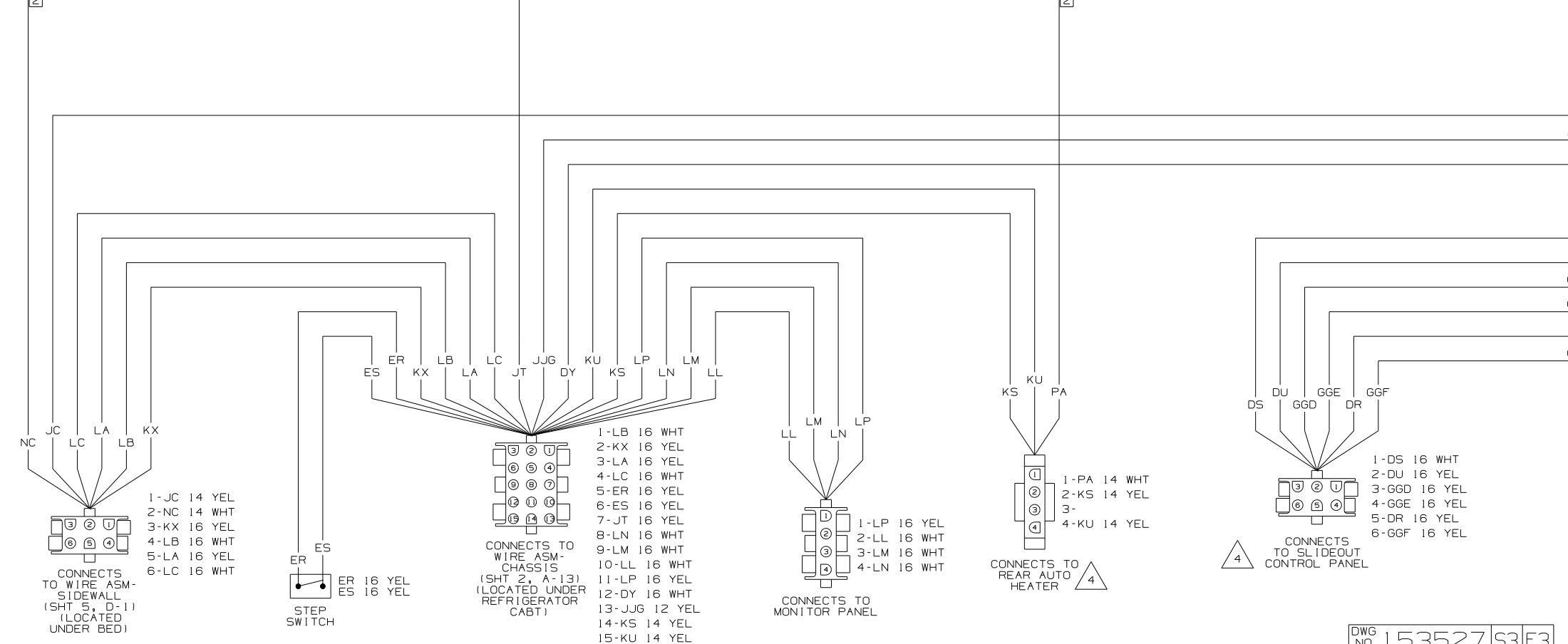

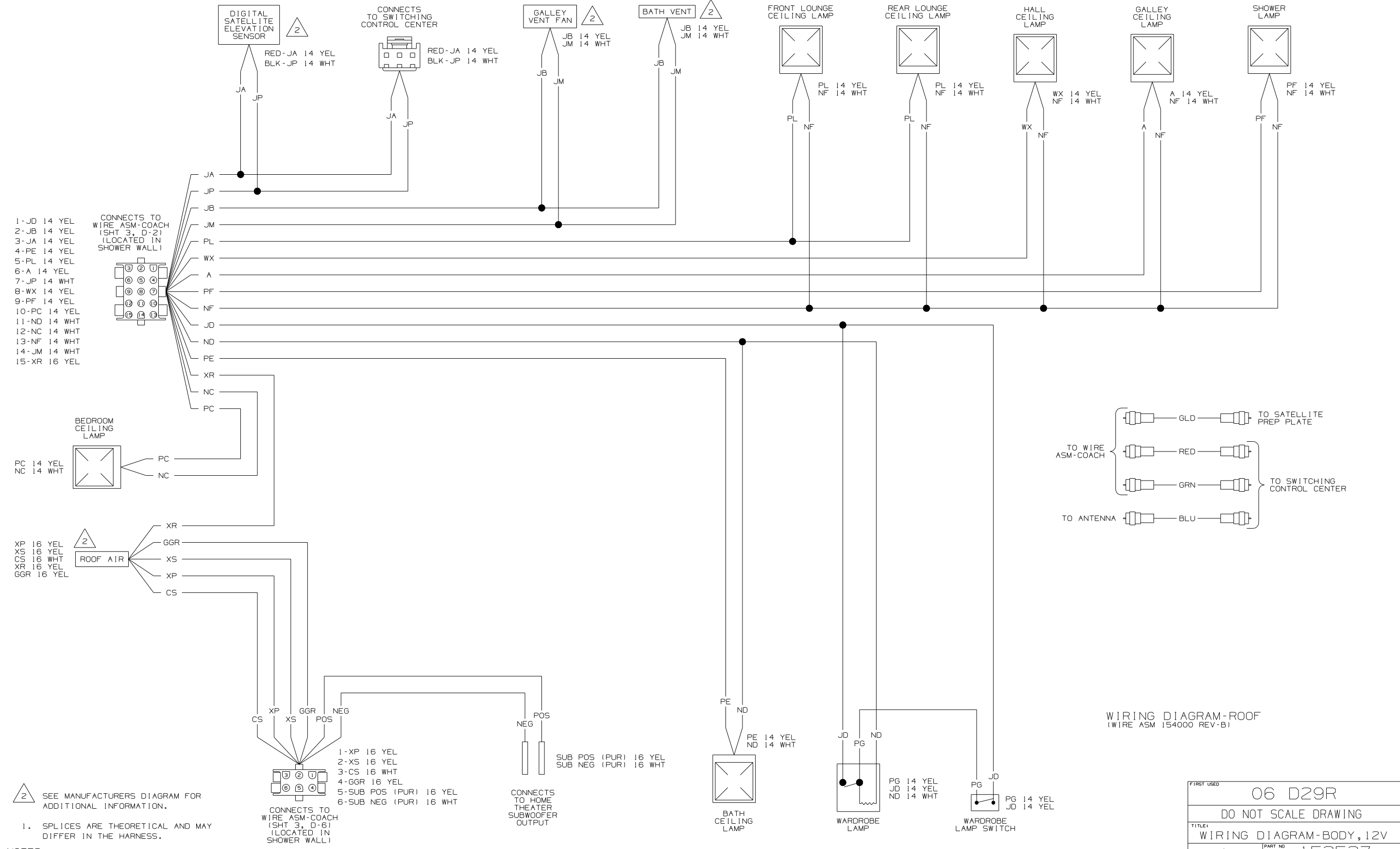

- 1-JD 14 YEL
- 2-JB 14 YEL
- 3-JA 14 YEL
- 4-PE 14 YEL
- 5-PL 14 YEL
- 6-A 14 YEL
- 7-JP 14 WHT
- 8-WX 14 YEL
- 9-PF 14 YEL
- 10-PC 14 YEL
- 11-ND 14 WHT
- 12-NC 14 WHT
- 13-NF 14 WHT
- 14-JM 14 WHT
- 15-XR 16 YEL

- XP 16 YEL
- XS 16 YEL
- CS 16 WHT
- XR 16 YEL
- GGR 16 YEL

- 1-XP 16 YEL
- 2-XS 16 YEL
- 3-CS 16 WHT
- 4-GGR 16 YEL
- 5-SUB POS (PUR) 16 YEL
- 6-SUB NEG (PUR) 16 WHT

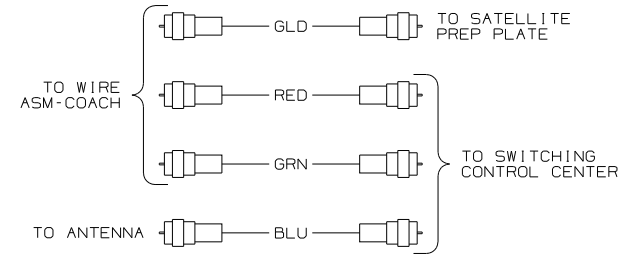

WIRING DIAGRAM-ROOF
(WIRE ASM 154000 REV-B1)

NOTES:

1. SPLICES ARE THEORETICAL AND MAY DIFFER IN THE HARNESS.

FIRST USED	06 D29R
DO NOT SCALE DRAWING	
TITLE	WIRING DIAGRAM-BODY, 12V
SHEET 4	PART NO 153527

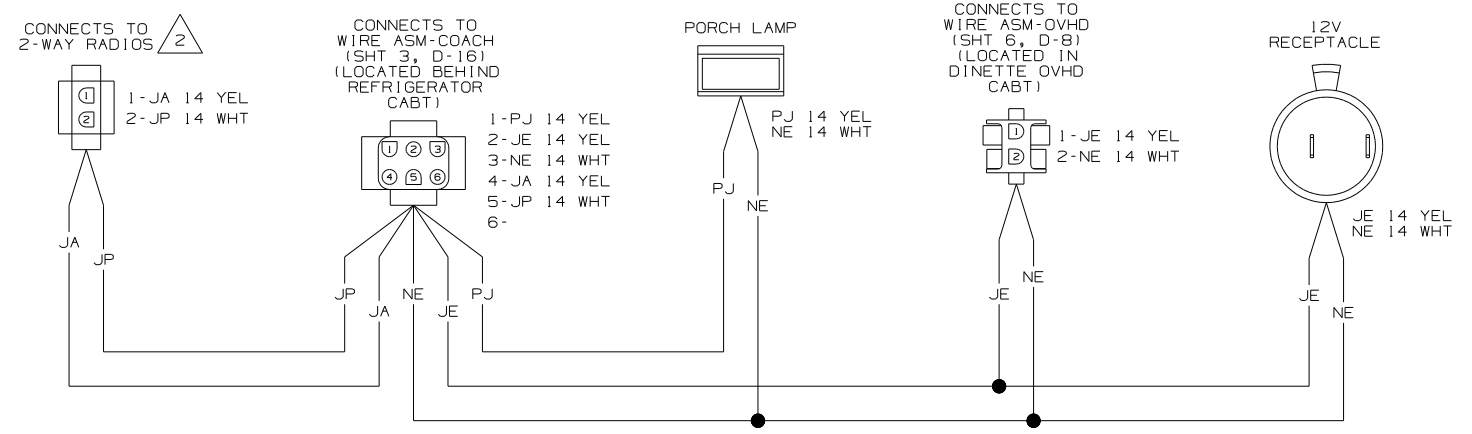

WIRING DIAGRAM-SIDEWALL
(WIRE ASM 149486 REV-B)

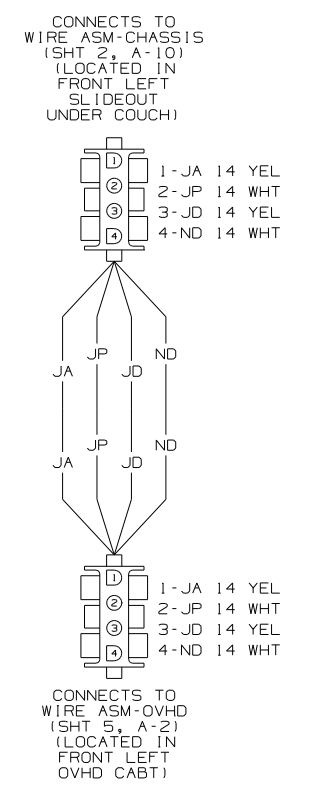

WIRING DIAGRAM-SLIDEOUT
(WIRE ASM 149654 REV-B)

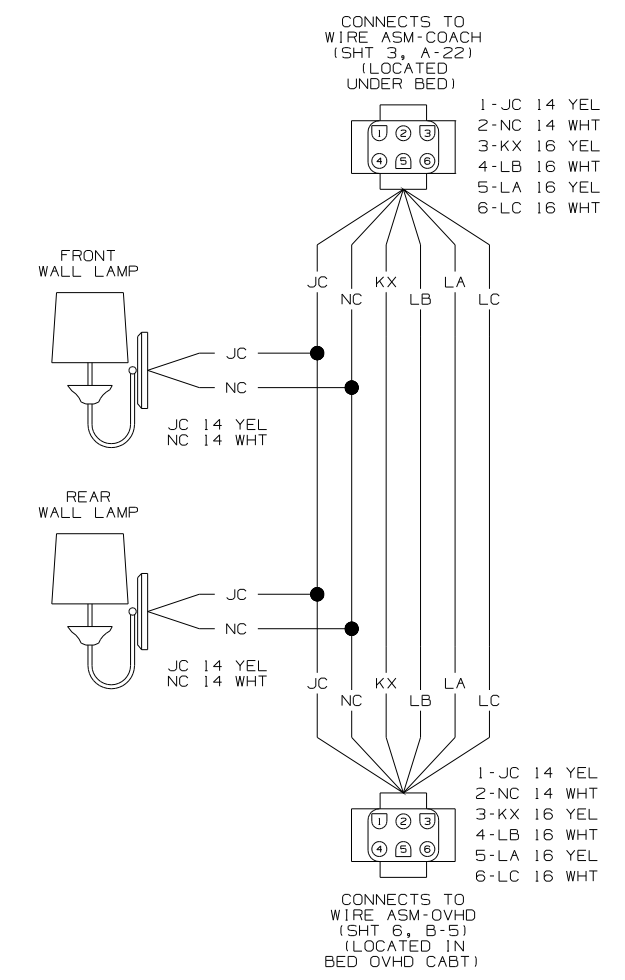

WIRING DIAGRAM-SIDEWALL
(WIRE ASM 149653 REV-A)

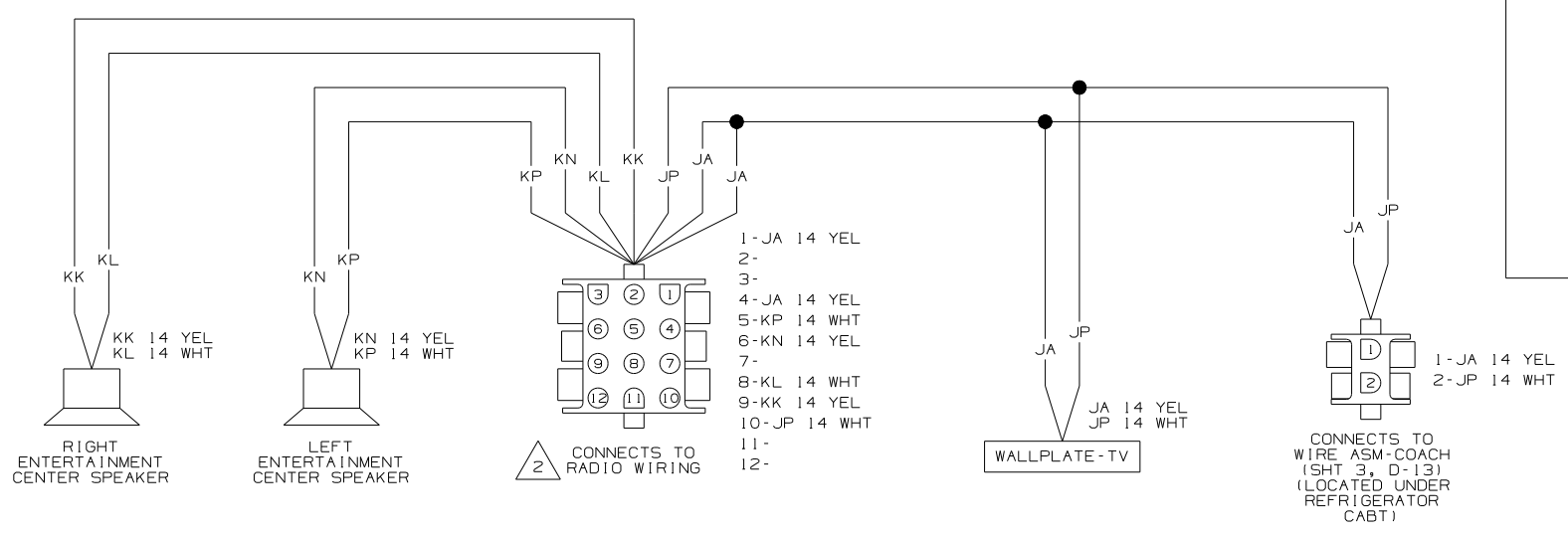

WIRING DIAGRAM-ENTERTAINMENT CTR
(WIRE ASM 125853-04 REV-L)

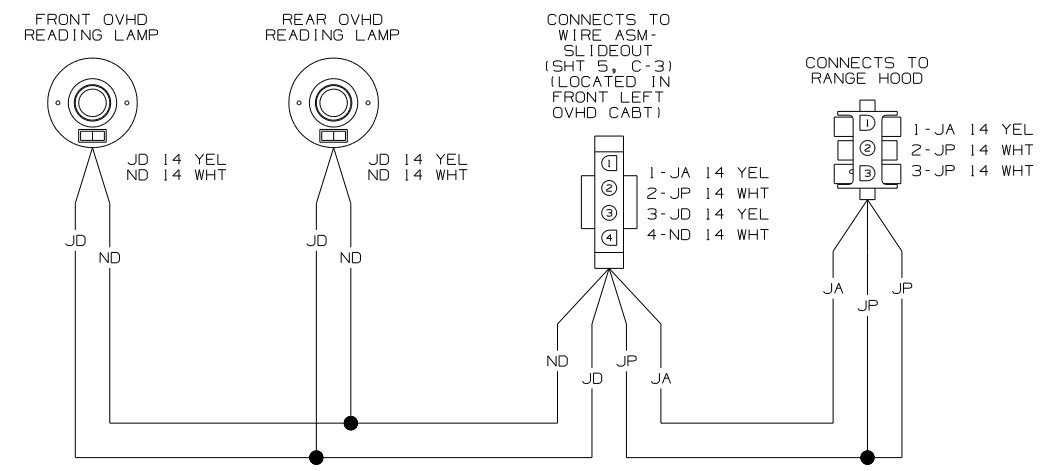

WIRING DIAGRAM-OVHD
(WIRE ASM 149485 REV-A)

SEE MANUFACTURER'S DIAGRAM FOR ADDITIONAL INFORMATION.

1. SPLICES ARE THEORETICAL AND MAY DIFFER IN THE HARNESS.

NOTES:

FIRST USED	06 D29R
TITLE	DO NOT SCALE DRAWING
TITLE	WIRING DIAGRAM-BODY, 12V
SHEET 5	PART NO 153527

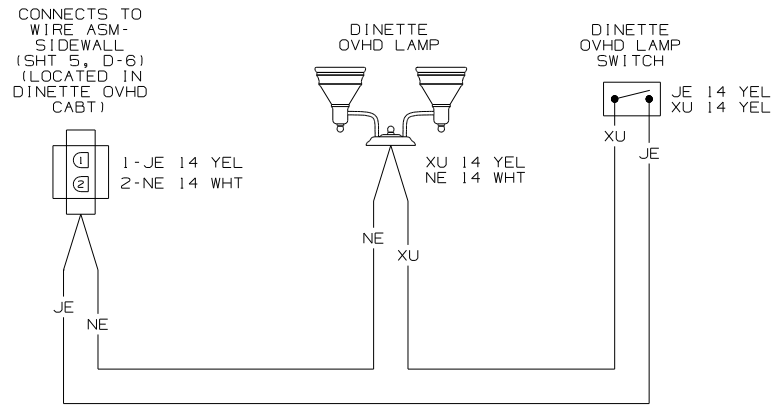

WIRING DIAGRAM-OVHD
(WIRE ASM 149917 REV-B)

- 1-LT FRT POS (WHT) 16 YEL
2-LT FRT NEG (WHT) 16 WHT
- 1-CENTER POS (GRN) 16 YEL
2-CENTER NEG (GRN) 16 WHT
- 1-RT FRT POS (RED) 16 YEL
2-RT FRT NEG (RED) 16 WHT
- 1-LT RR POS (BLU) 16 YEL
2-LT RR NEG (BLU) 16 WHT
- 1-RT RR POS (GRY) 16 YEL
2-RT RR NEG (GRY) 16 WHT

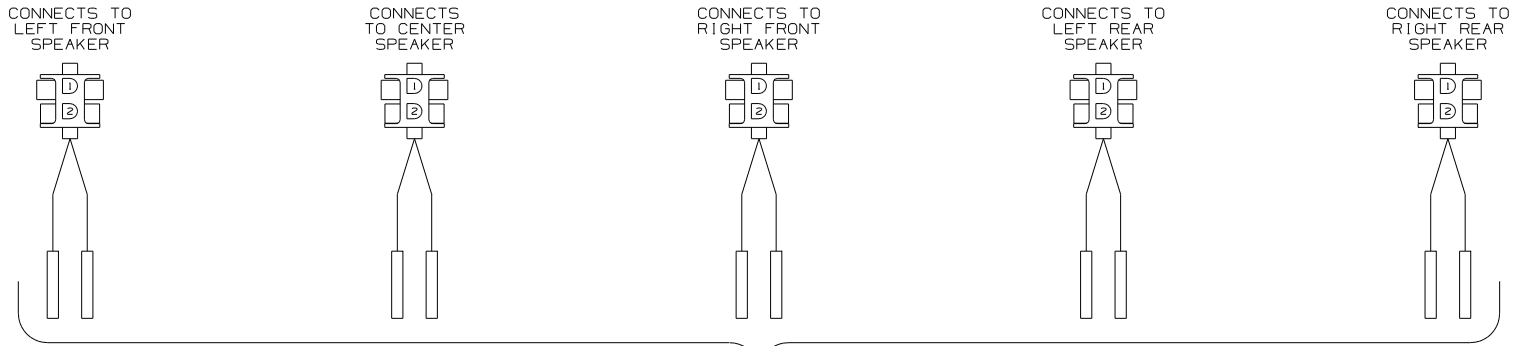

- CONNECTS TO SPEAKER OUTPUTS ON HOME THEATER AMPLIFIER
- RT FRT POS (RED) 16 YEL
 - RT FRT NEG (RED) 16 WHT
 - CENTER POS (GRN) 16 YEL
 - CENTER NEG (GRN) 16 WHT
 - LT FRT POS (WHT) 16 YEL
 - LT FRT NEG (WHT) 16 WHT
 - LT RR POS (BLU) 16 YEL
 - LT RR NEG (BLU) 16 WHT
 - RT RR POS (GRY) 16 YEL
 - RT RR NEG (GRY) 16 WHT

WIRING DIAGRAM-HOME THEATER EXTENSION
(WIRE ASM 149963-02 REV-F)

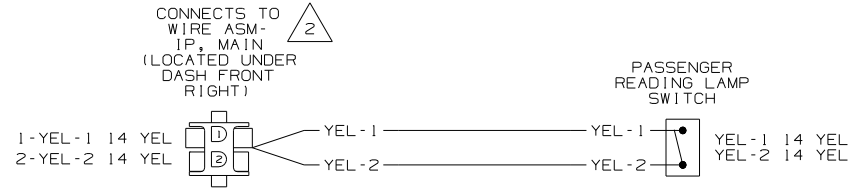

WIRING DIAGRAM-EXTENSION, 2 PIN
(WIRE ASM 147579-02 REV-A)

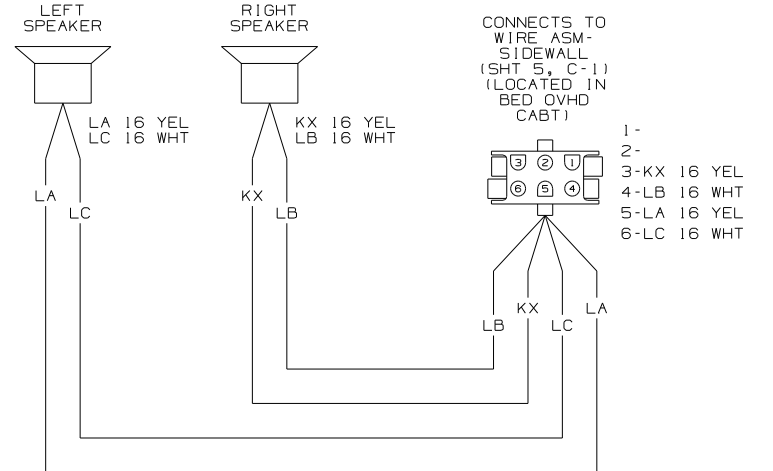

WIRING DIAGRAM-OVHD
(WIRE ASM 149655 REV-B)

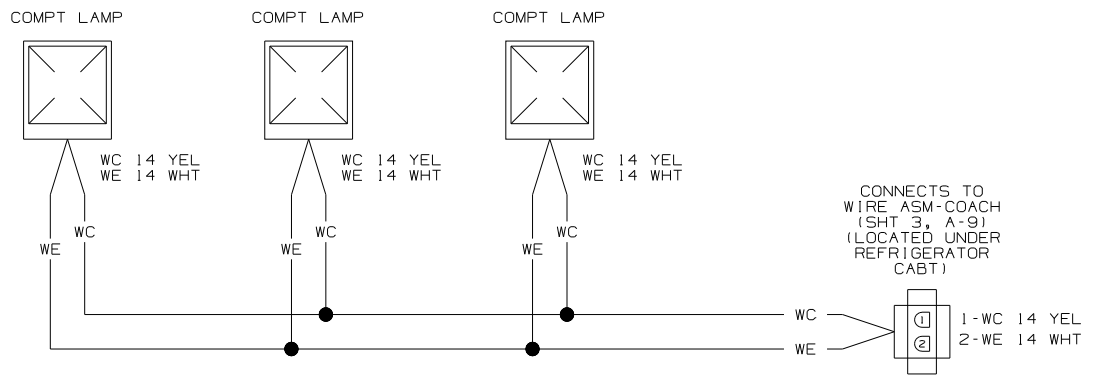

WIRING DIAGRAM-COMPT LAMP
(WIRE ASM 149929 REV-C)

SEE WIRING DIAGRAM-AUTO FOR ADDITIONAL INFORMATION.

1. SPLICES ARE THEORETICAL AND MAY DIFFER IN THE HARNESS.

NOTES:

FIRST USED	06 D29R
TITLE	DO NOT SCALE DRAWING
	WIRING DIAGRAM-BODY, 12V
SHEET 6	PART NO 153527

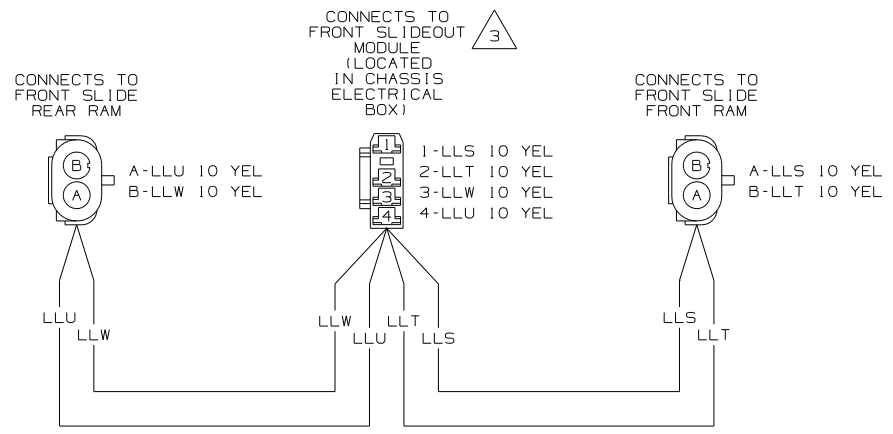

WIRING DIAGRAM-SLIDEOUT RAMS,FRONT
(WIRE ASM 149553-03 REV-H)

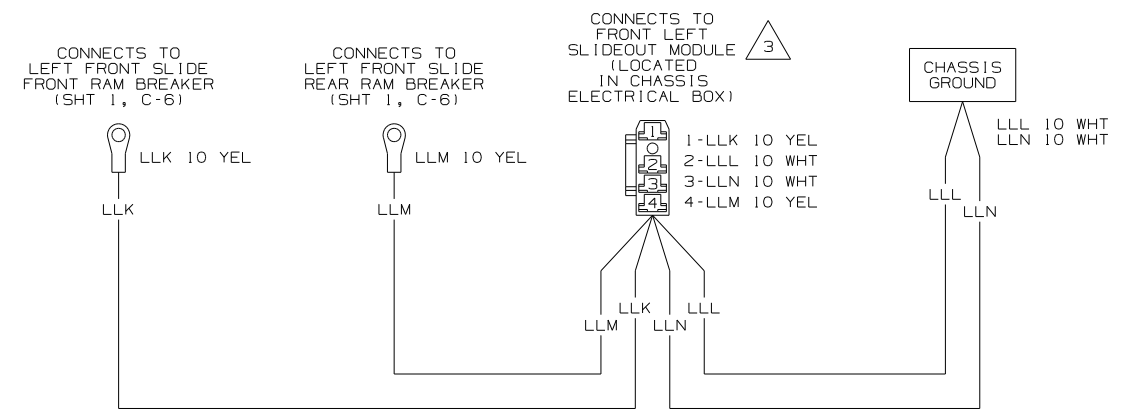

WIRING DIAGRAM-SLIDEOUT POWER
(WIRE ASM 149552-04 REV-J)

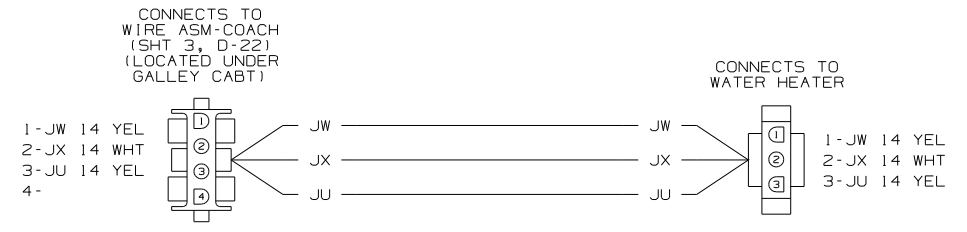

WIRING DIAGRAM-JUMPER,WTR HTR
(WIRE ASM 142263 REV-A)

- 3 SEE MANUFACTURER'S DIAGRAM FOR ADDITIONAL INFORMATION.
- 2 SEE WIRING DIAGRAM-AUTO FOR ADDITIONAL INFORMATION.
1. SPLICES ARE THEORETICAL AND MAY DIFFER IN THE HARNESS.

NOTES:

FIRST USED	06 D29R
TITLE	DO NOT SCALE DRAWING
TITLE	WIRING DIAGRAM-BODY, 12V
SHEET 7	PART NO 153527