



DANGER

Danger of electrical shock, burns or death. Always remove all power sources before attempting any repair, service or diagnostic work. Power can be present from shore power, generator, inverter or battery. All power sources must be disabled and secured before performing any service.



CAUTION

If you lack the skills, tools or equipment to perform diagnostic or repair work leave such work to an authorized Winnebago Industries dealer or other qualified shop.

DRAWING NO.	FEATURES
154610-01	-----
154610-11	(1B1) (12D)
154610-15	(265) (12D)

RELEASE	REV DATE	DWG NO
A		154610
REV ZONE	REVISION RECORD	DATE DFR-ORIG

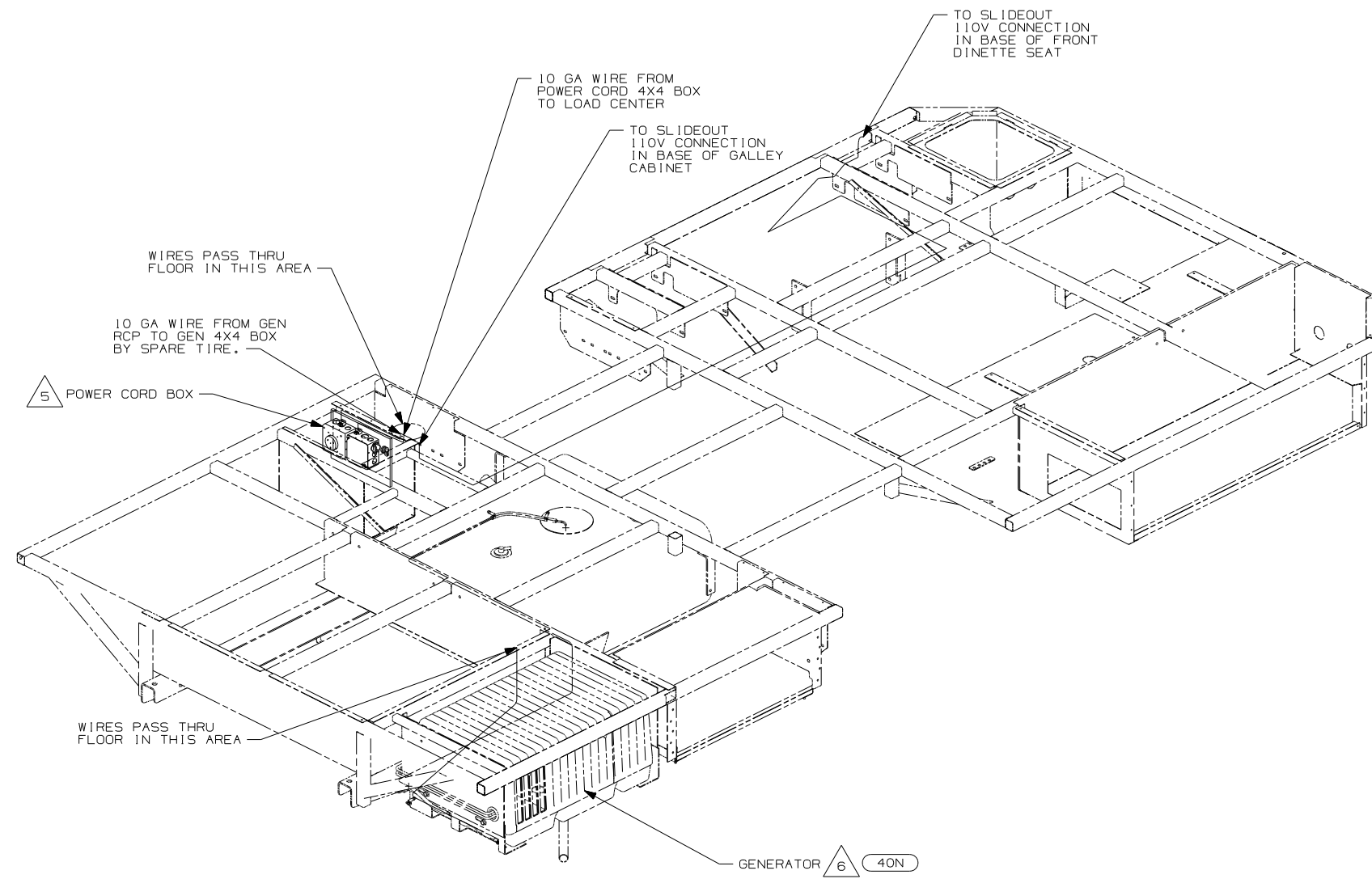

- (40N) GEN-4.0KW-ONANGAS-MICROQUJET
- (12D) ELECTRICAL SYSTEM 30 AMP
- (265) CODES/STANDARDS-CSA/CMVSS
- (1B1) CODES/STANDARDS USA

(1B1) (265) (12D)

WINNEBAGO COPYRIGHT 2006 WINNEBAGO INDUSTRIES, INC.

DFTR	ORIG. DATE
CHKR	ALL DIMENSIONS ARE IN MILLIMETERS
P.E.	
M.E.	FIRST USED
DSNR	06 723D

UNSPECIFIED TOLERANCES ARE: MATERIAL:

WHOLE DIM (X) :
ONE-PLACE (X.X) :
TWO-PLACE (X.XX) :
ANGLE :

THIRD ANGLE PROJECTION

DO NOT SCALE DRAWING

TITLE: WRING INSTL.-BODY, 110V

SHEET 1 OF 3 PART NO 154610 REV

REF: 1 6/15/2006

- 6 SEE GENERATOR INSTALLATION FOR ADDITIONAL INFORMATION.
- 5 SEE LOAD CENTER/ATS ASM FOR ADDITIONAL INFORMATION.
4. SEE WIRING DIAGRAM-BODY, 110V FOR ADDITIONAL INFORMATION.
3. ALL GROUND WIRE TO BE COVERED WITH TUBING 8041-02-000.
2. ALL 110V WIRE TO BE CLAMPED WITH CLAMP 10497-05-000 WITHIN 200MM OF OUTLET BOXES, USE SCREW G67-10-12B.
1. ALL WIRES TO BE SECURED WITH CLAMP 10495-01-000 OR CLIP B0734-01-000 EVERY 600MM. USE SCREW G67-10-12B UNLESS OTHERWISE SPECIFIED.

FOR ELECTRICAL TORQUE SPECIFICATIONS SEE DWG NO. 128783-01-000

(X-X) FOR ELECTRICAL CALLOUTS SEE DWG NO. 121339-01-000

NOTES:

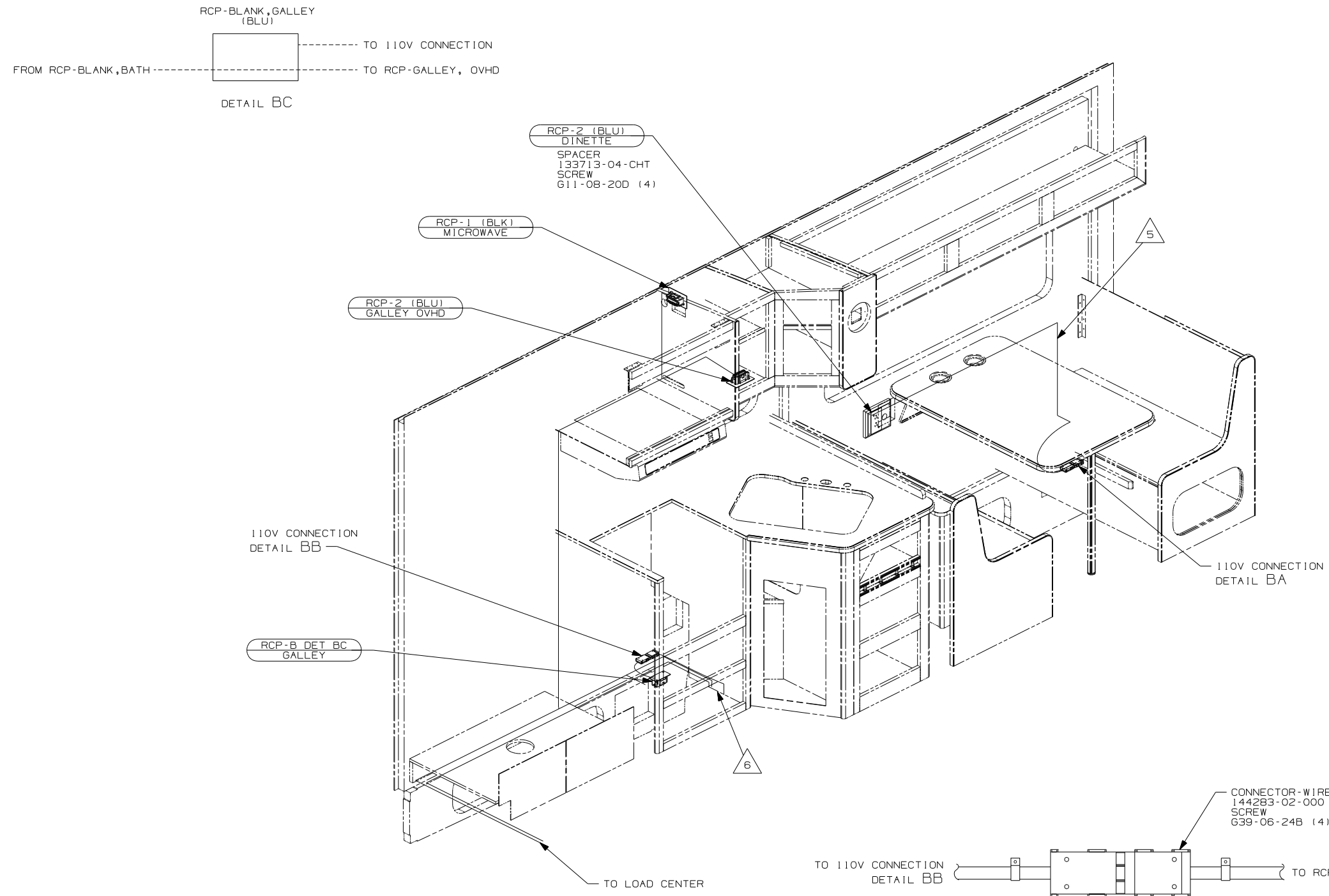

- △ 6 WIRE ROUTED THROUGH FLOOR AT THIS POINT.
- △ 5 WIRE IN SIDEWALL.
- 4. SEE WIRING DIAGRAM-BODY, 110V FOR ADDITIONAL INFORMATION.
- 3. ALL GROUND WIRE TO BE COVERED WITH TUBING 8041-02-000.
- 2. ALL 110V WIRE TO BE CLAMPED WITH CLAMP 10497-05-000 WITHIN 200MM OF OUTLET BOXES, USE SCREW 667-10-12B.
- 1. ALL WIRES TO BE SECURED WITH CLAMP 10495-01-000 OR CLIP 80734-01-000 EVERY 600MM. USE SCREW 667-10-12B UNLESS OTHERWISE SPECIFIED.

NOTES:

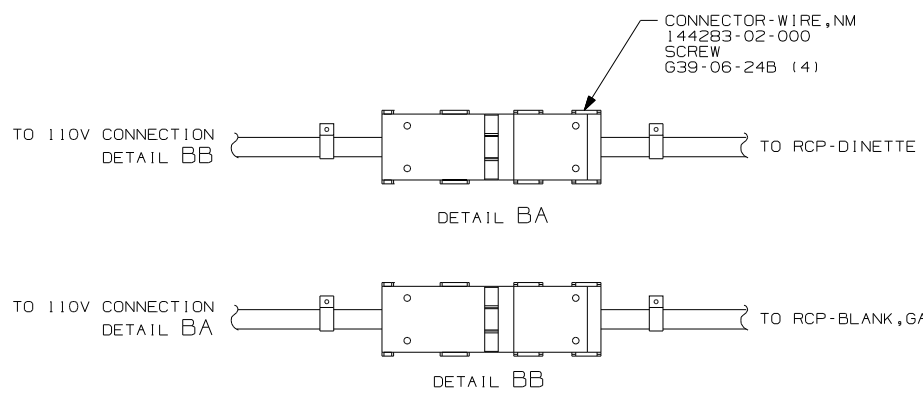

FOR ELECTRICAL TORQUE SPECIFICATIONS SEE DWG NO. 128783-01-000

FOR ELECTRICAL CALLOUTS SEE DWG NO. 121339-01-000

- 12D ELECTRICAL SYSTEM 30 AMP
- 265 CODES/STANDARDS-CSA/CMVSS
- 1B1 CODES/STANDARDS USA

FIRST USED	06 723D	
TITLE:	DO NOT SCALE DRAWING	
	WRING INSTL.-BODY, 110V	
SHEET 2	PART NO	REV
	154610	

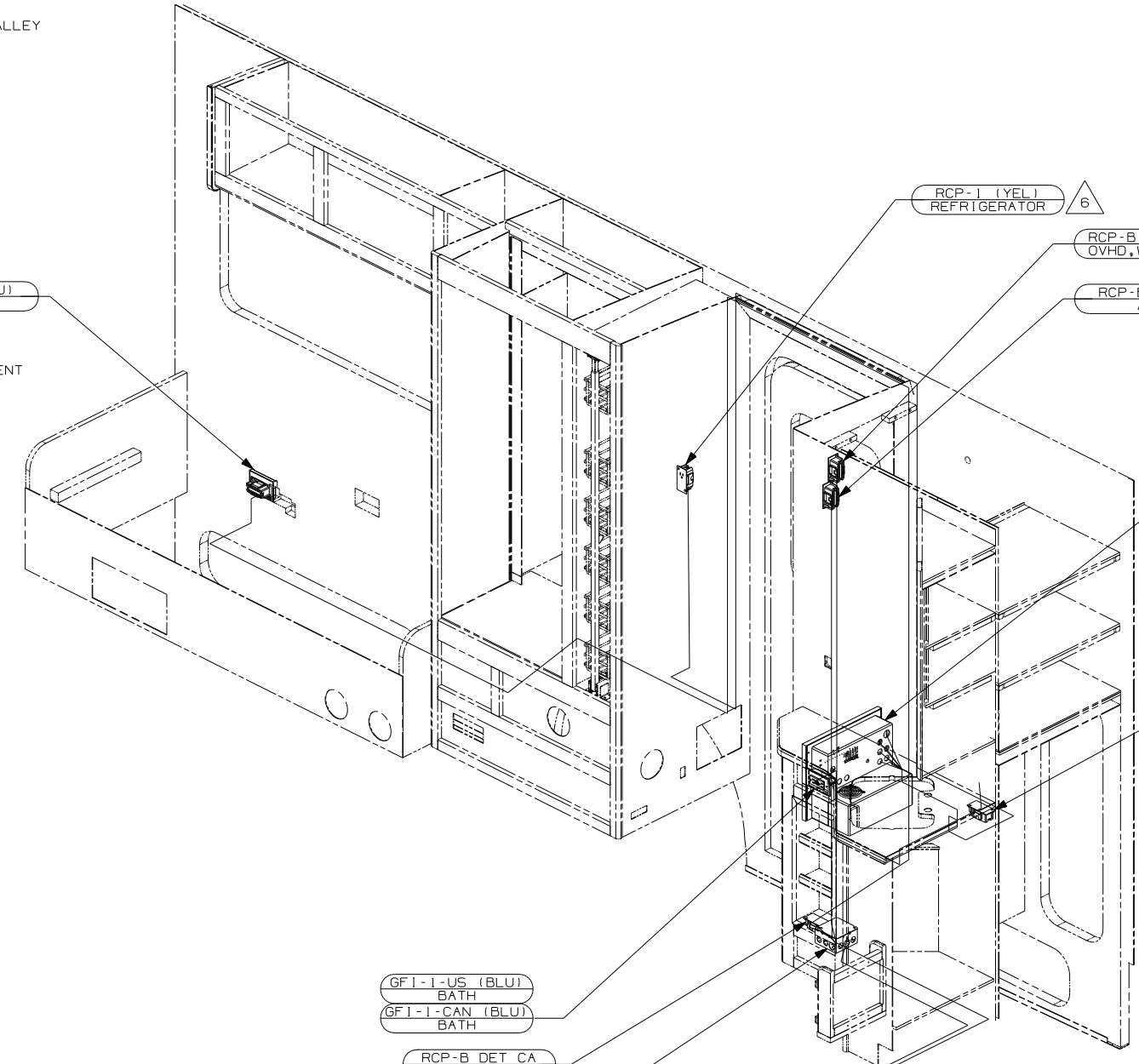
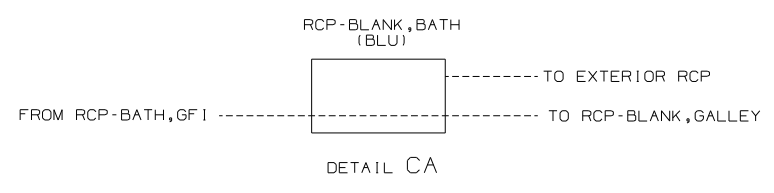

- 7 SEE LOAD CENTER/ATS ASM FOR ADDITIONAL INFORMATION.
- 6 LOCATE RECEPTACLE ON REFRIGERATOR TIEDOWN BRACKET.
- 5 SEE EXTERIOR ENTERTAINMENT CENTER ASM FOR ADDITIONAL INFORMATION.
- 4 SEE GENERATOR INSTL. FOR ADDITIONAL INFORMATION.
- 3 NOT USED WITH 1D5
- 2 THE BRN-2 WIRE IN THE RCP-B WARDROBE IS TO BE WIRED INTO THE INVERTER OUTPUT WITH OPTION 40B

1. ALL WIRES TO BE SECURED WITH CLAMP 10495-01-000 OR CLIP 80734-01-000 EVERY 600MM. USE SCREW 667-10-12B UNLESS OTHERWISE SPECIFIED.

NOTES:

- 40A INVERTER-DC/AC WITHOUT
- 40B INVERTER-DC/AC, 300 WATT
- 40N GEN-4.0KW-ONANGAS-MICROQUIET
- 39A EXT RECEPTACLE DPLX 120VAC
- 1D5 ENTERTAINMENT CENTR/EXT W/CD
- 265 CODES/STANDARDS-CSA/CMVSS
- 1B1 CODES/STANDARDS USA

FIRST USED		06 723D	
DO NOT SCALE DRAWING			
TITLE: WRING INSTL.-BODY, 110V			
SHEET 3	PART NO	154610	
REV			

FOR ELECTRICAL TORQUE SPECIFICATIONS SEE DWG NO. 128783-01-000

FOR ELECTRICAL CALLOUTS SEE DWG NO. 121339-01-000