



DANGER

Danger of electrical shock, burns or death. Always remove all power sources before attempting any repair, service or diagnostic work. Power can be present from shore power, generator, inverter or battery. All power sources must be disabled and secured before performing any service.



CAUTION

If you lack the skills, tools or equipment to perform diagnostic or repair work leave such work to an authorized Winnebago Industries dealer or other qualified shop.

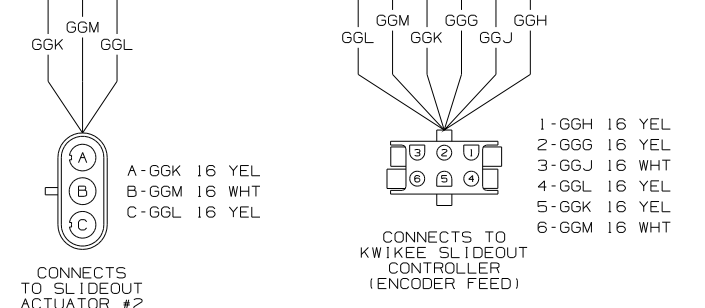
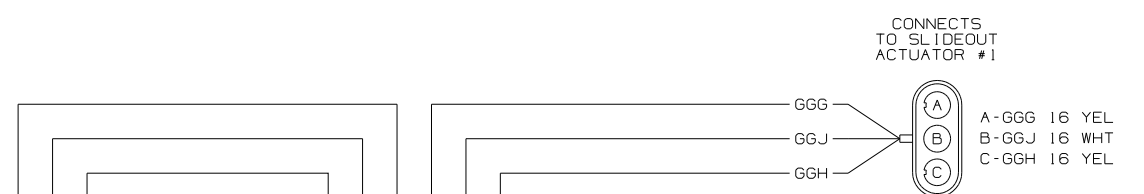
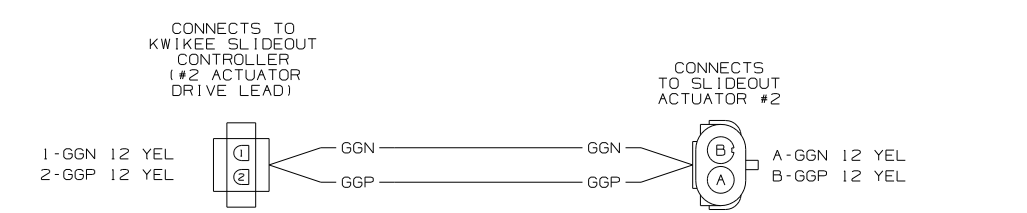
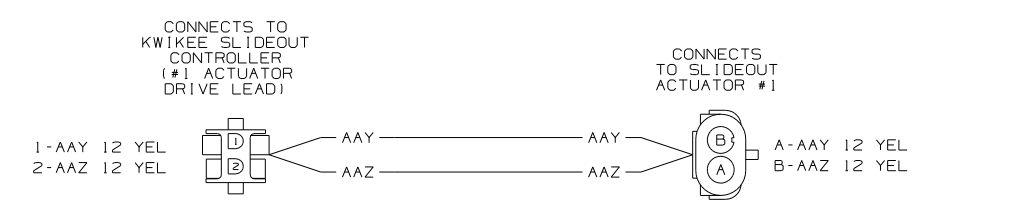
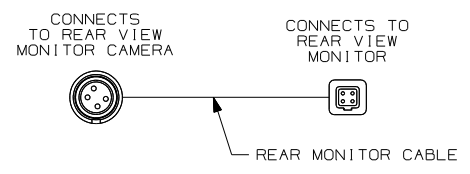
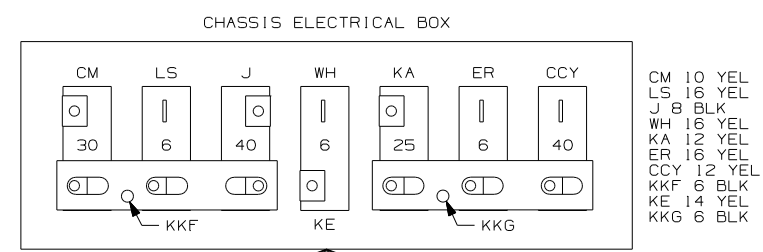

WIRING DIAGRAM-CHASSIS
(WIRE ASM 152757 REV-H)

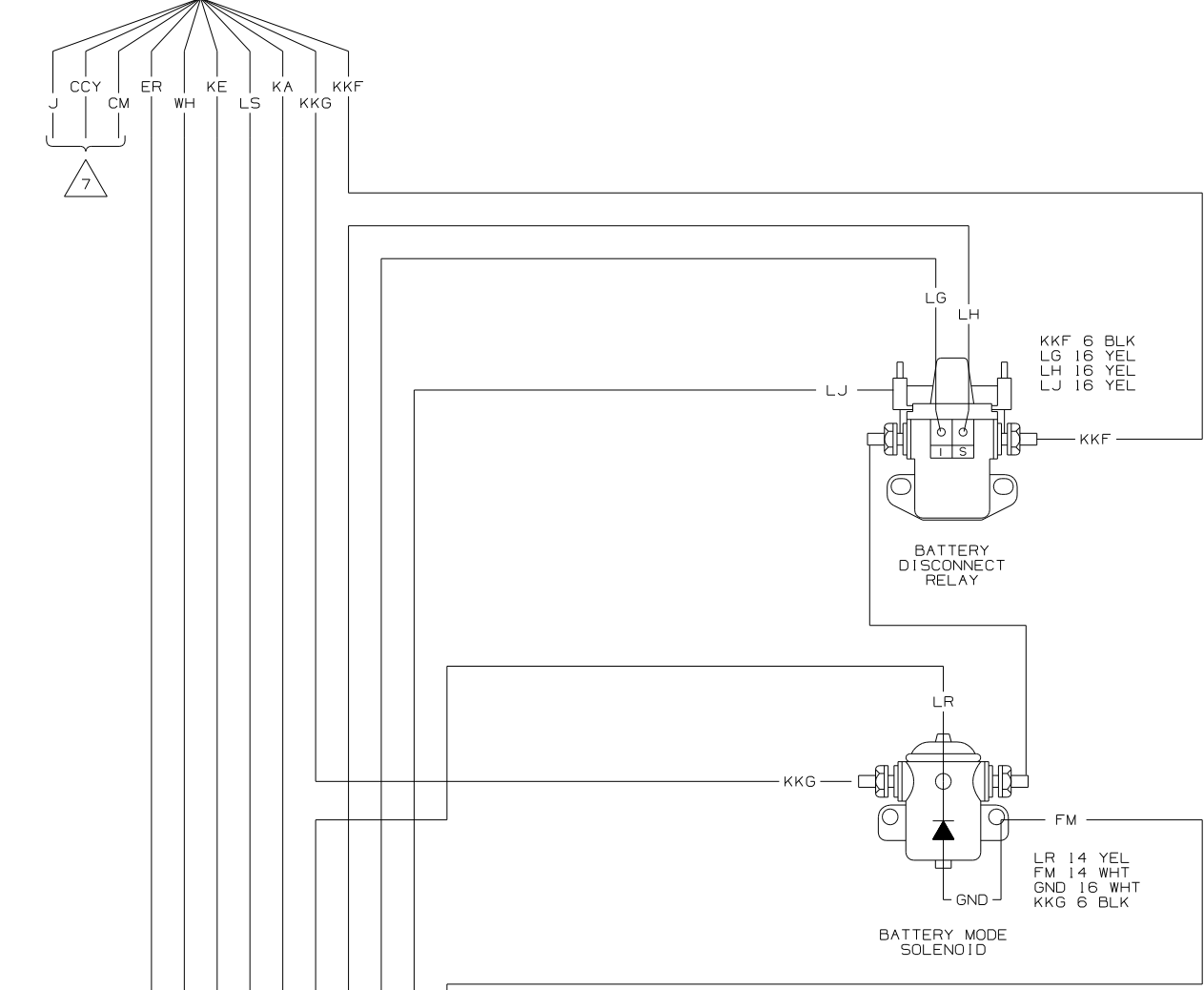

WIRING DIAGRAM-ELECTRICAL BOX
(WIRE ASM 124125-04 REV-L)

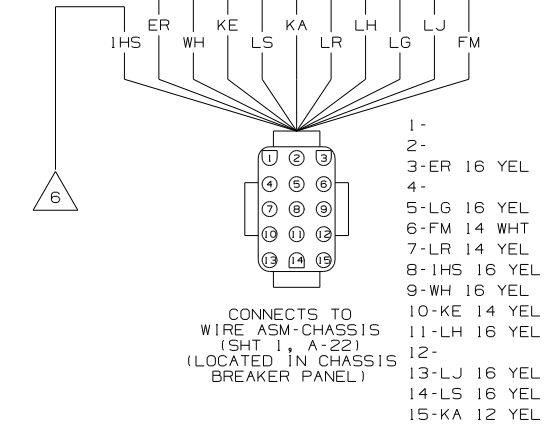

WINNEBAGO		COPYRIGHT 2004 WINNEBAGO INDUSTRIES, INC.	
DFTR	ORIG. DATE	ALL DIMENSIONS ARE IN MILLIMETERS	
CHR		M.E.	
P.E.		FIRST USED	
M.E.		06 331C & T	
DSNR		UNSPECIFIED TOLERANCES ARE:	
		MATERIAL:	
		HOLE DIM (X) :	
		ONE-PLACE (X.X) :	
		TWO-PLACE (X.XX) :	
		ANGLE :	
		THIRD ANGLE PROJECTION :	
DO NOT SCALE DRAWING			
TITLE: WIRING DIAGRAM-BODY, 12V			
SHEET 1 of 7	PART NO	152792	

CONNECTS TO GENERATOR

- A-LN 16 WHT
- B-LM 16 WHT
- C-LL 16 WHT
- D-
- E-
- F-LP 16 YEL
- G-
- H-

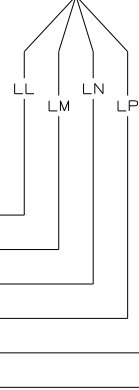
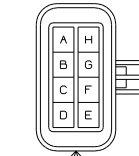

CONNECTS TO WIRE ASM-TANK, WATER

- 1-XH 16 YEL
- 2-GL 16 WHT

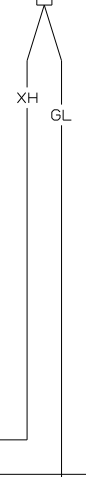

LP TANK

- JT 16 YEL
- MP 16 WHT

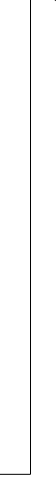
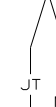

DOMELAMP

- CCU 16 YEL
- GE 16 YEL
- MU 14 WHT

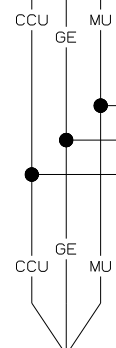
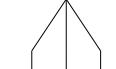

DOMELAMP

- CCU 16 YEL
- GE 16 YEL
- MU 14 WHT

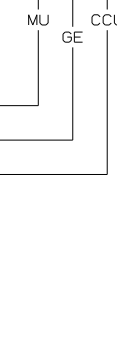

CONNECTS TO FORD WIRING

- BLK-MU 14 WHT
- LT GRN/YEL-CCU 16 YEL
- BLK/LT BLU-GE 16 YEL

CONNECTS TO CIRCUIT BREAKER COACH POWER (SHT 1, D-4)

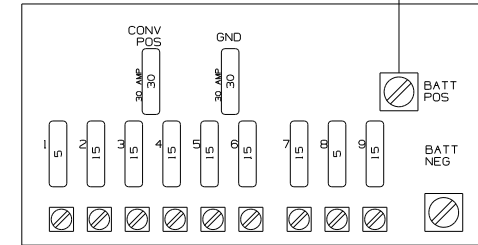
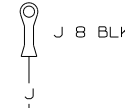

GND

XJ

- 1-XJ 16 YEL
- 2-GL 16 WHT

CONNECTS TO WIRE ASM-TANK, MAIN HOLDING

CONNECTS TO CIRCUIT BREAKER SLIDEOUT (SHT 1, D-4)

KWIKEE CONTROLLER

- T 10 WHT
- CCY 10 YEL

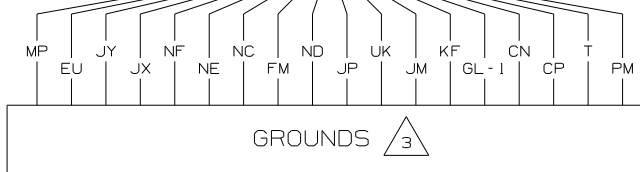

- | | | | |
|-----------|-----------|-----------|-------------|
| NF 14 WHT | PM 12 WHT | NE 14 WHT | GL-1 14 WHT |
| JP 14 WHT | MP 16 WHT | NC 14 WHT | CN 10 WHT |
| UK 16 WHT | EU 16 WHT | FM 14 WHT | CP 12 WHT |
| JM 14 WHT | JY 12 WHT | ND 14 WHT | T 10 WHT |
| KF 16 WHT | JX 14 WHT | | |

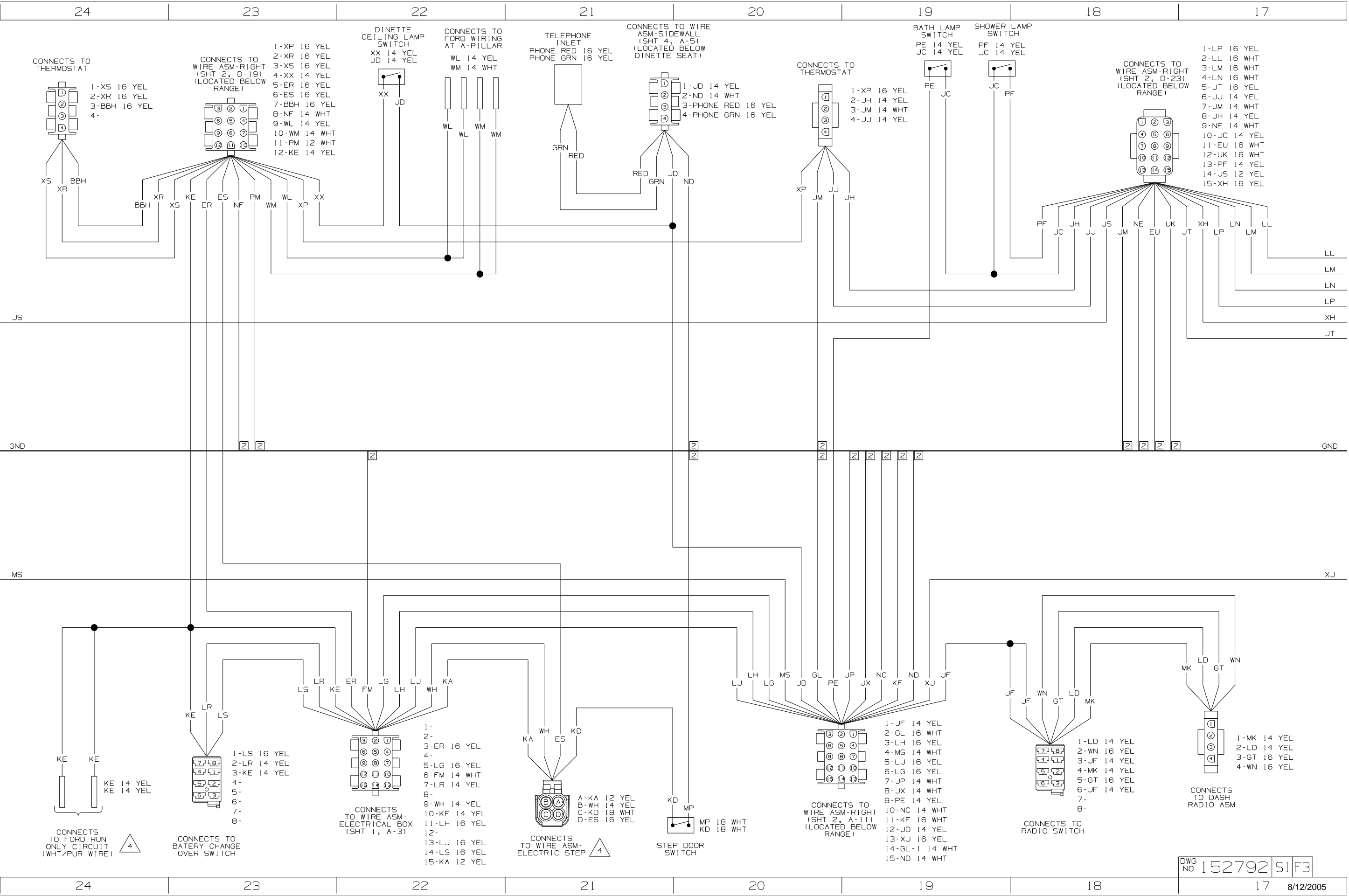

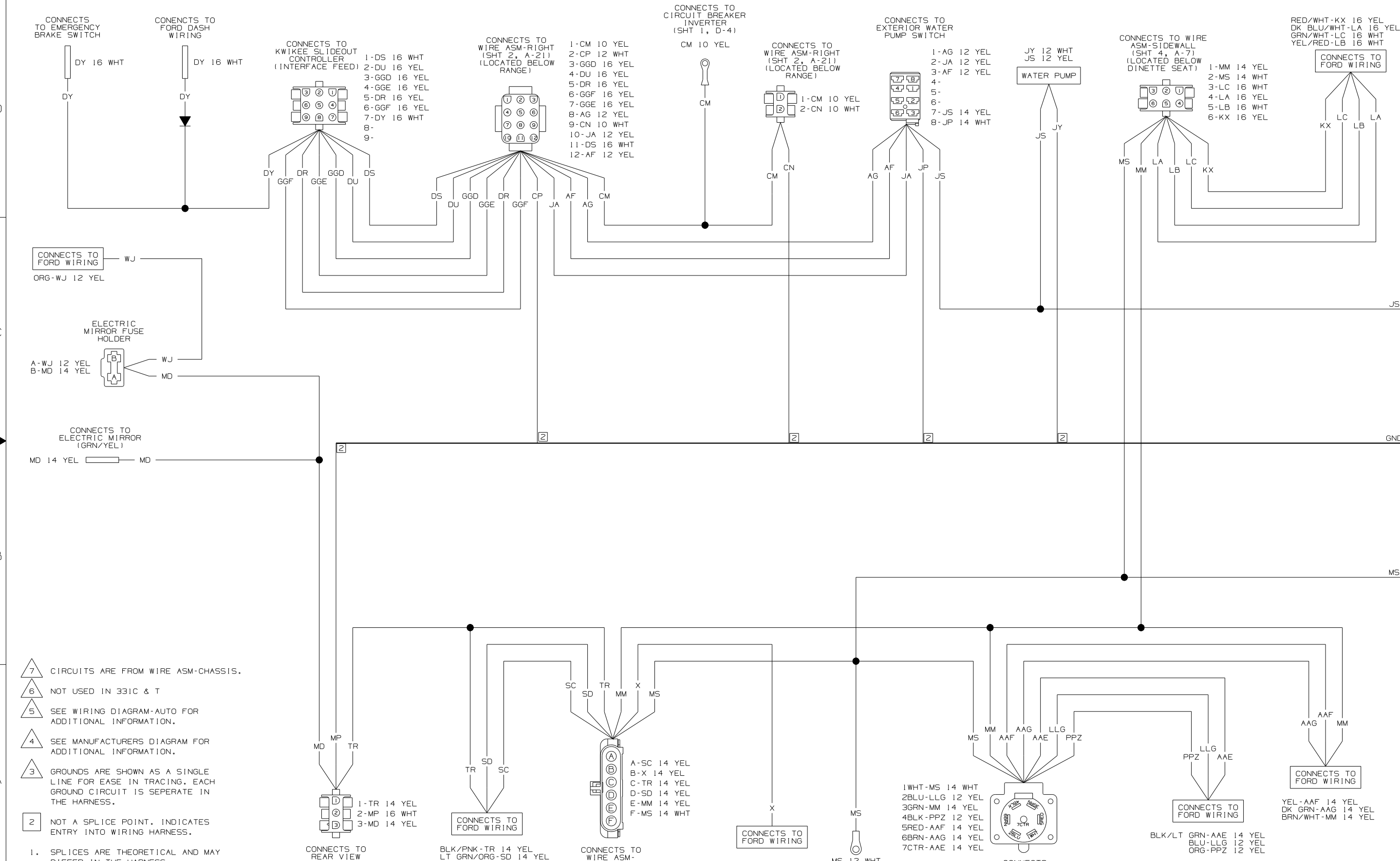

- 7 CIRCUITS ARE FROM WIRE ASM-CHASSIS.
 - 6 NOT USED IN 331C & T
 - 5 SEE WIRING DIAGRAM-AUTO FOR ADDITIONAL INFORMATION.
 - 4 SEE MANUFACTURERS DIAGRAM FOR ADDITIONAL INFORMATION.
 - 3 GROUNDS ARE SHOWN AS A SINGLE LINE FOR EASE IN TRACING. EACH GROUND CIRCUIT IS SEPERATE IN THE HARNESS.
 - 2 NOT A SPLICE POINT. INDICATES ENTRY INTO WIRING HARNESS.
1. SPLICES ARE THEORETICAL AND MAY DIFFER IN THE HARNESS.

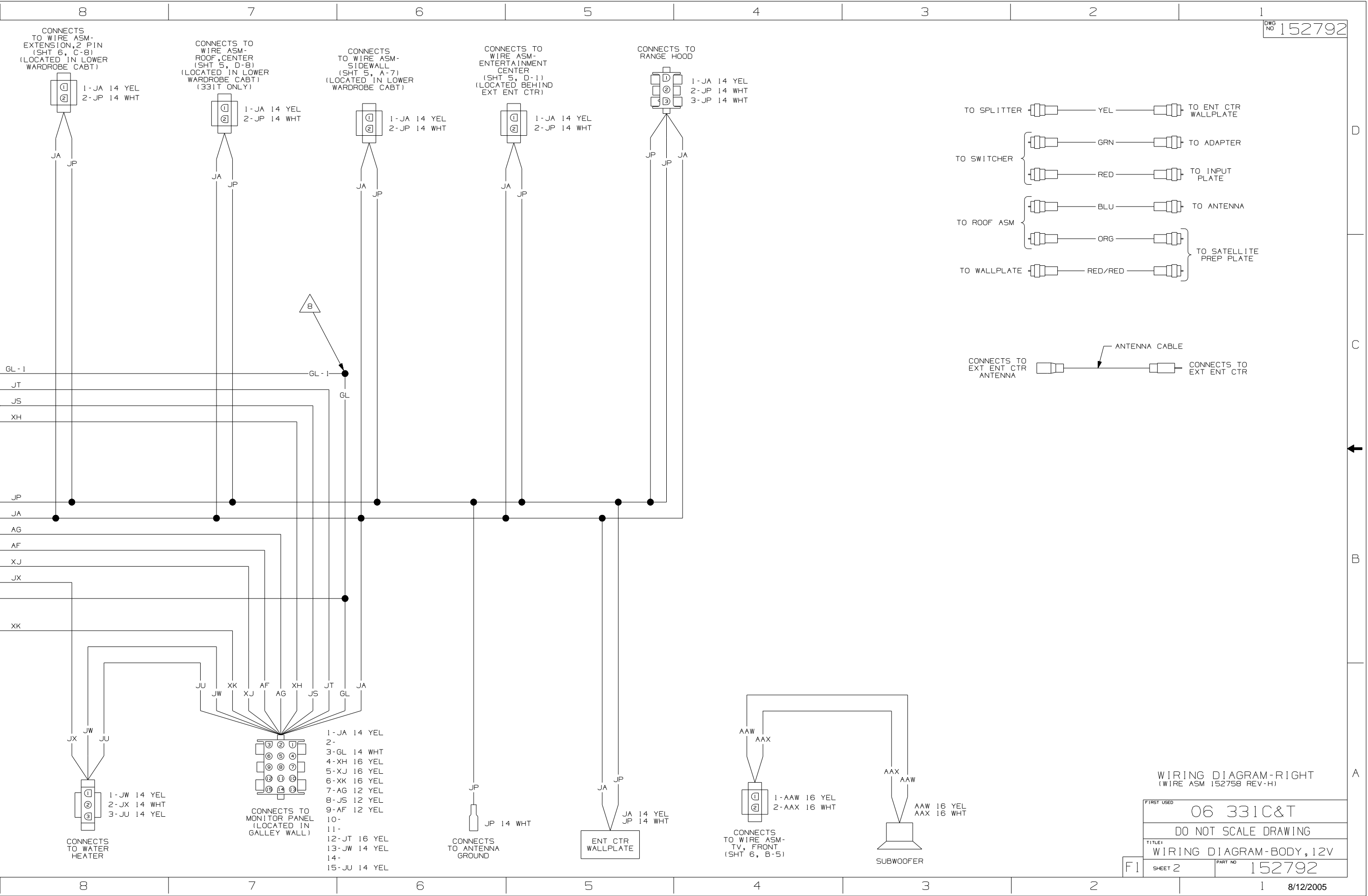

CONNECTS TO WIRE ASM- EXTENSION, 2 PIN (SHT 6, C-8) (LOCATED IN LOWER WARDROBE CABT)

CONNECTS TO WIRE ASM- ROOF, CENTER (SHT 5, D-8) (LOCATED IN LOWER WARDROBE CABT) (331T ONLY)

CONNECTS TO WIRE ASM- SIDEWALL (SHT 5, A-7) (LOCATED IN LOWER WARDROBE CABT)

CONNECTS TO WIRE ASM- ENTERTAINMENT CENTER (SHT 5, D-1) (LOCATED BEHIND EXT ENT CTR)

CONNECTS TO RANGE HOOD

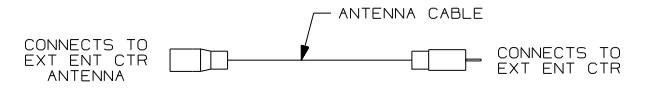
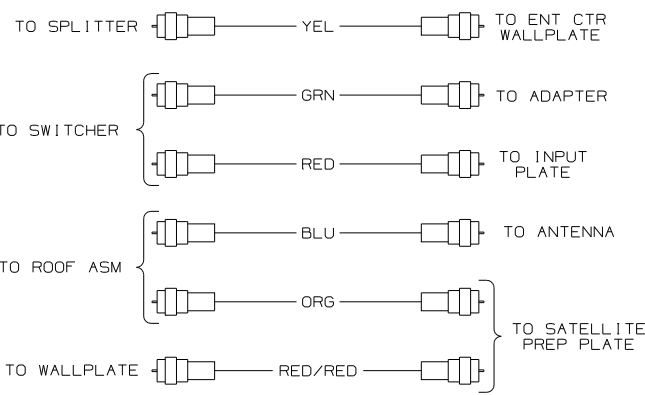

1-JA 14 YEL
2-JP 14 WHT

1-JA 14 YEL
2-JP 14 WHT

1-JA 14 YEL
2-JP 14 WHT

1-JA 14 YEL
2-JP 14 WHT

1-JA 14 YEL
2-JP 14 WHT
3-JP 14 WHT

GL-1
JT
JS
XH
JP
JA
AG
AF
XJ
JX
XK

JU JW XK XJ AF AG XH JS GL JA

1-JA 14 YEL
2-
3-GL 14 WHT
4-XH 16 YEL
5-XJ 16 YEL
6-XK 16 YEL
7-AG 12 YEL
8-JS 12 YEL
9-AF 12 YEL
10-
11-
12-JT 16 YEL
13-JW 14 YEL
14-
15-JU 14 YEL

1-JW 14 YEL
2-JX 14 WHT
3-JU 14 YEL

JP 14 WHT

JA 14 YEL
JP 14 WHT

1-AAW 16 YEL
2-AAX 16 WHT

AAW 16 YEL
AAX 16 WHT

WIRING DIAGRAM-RIGHT (WIRE ASM 152758 REV-H)

FIRST USED 06 331C&T

DO NOT SCALE DRAWING

TITLE: WIRING DIAGRAM-BODY, 12V

F1 SHEET 2

PART NO 152792

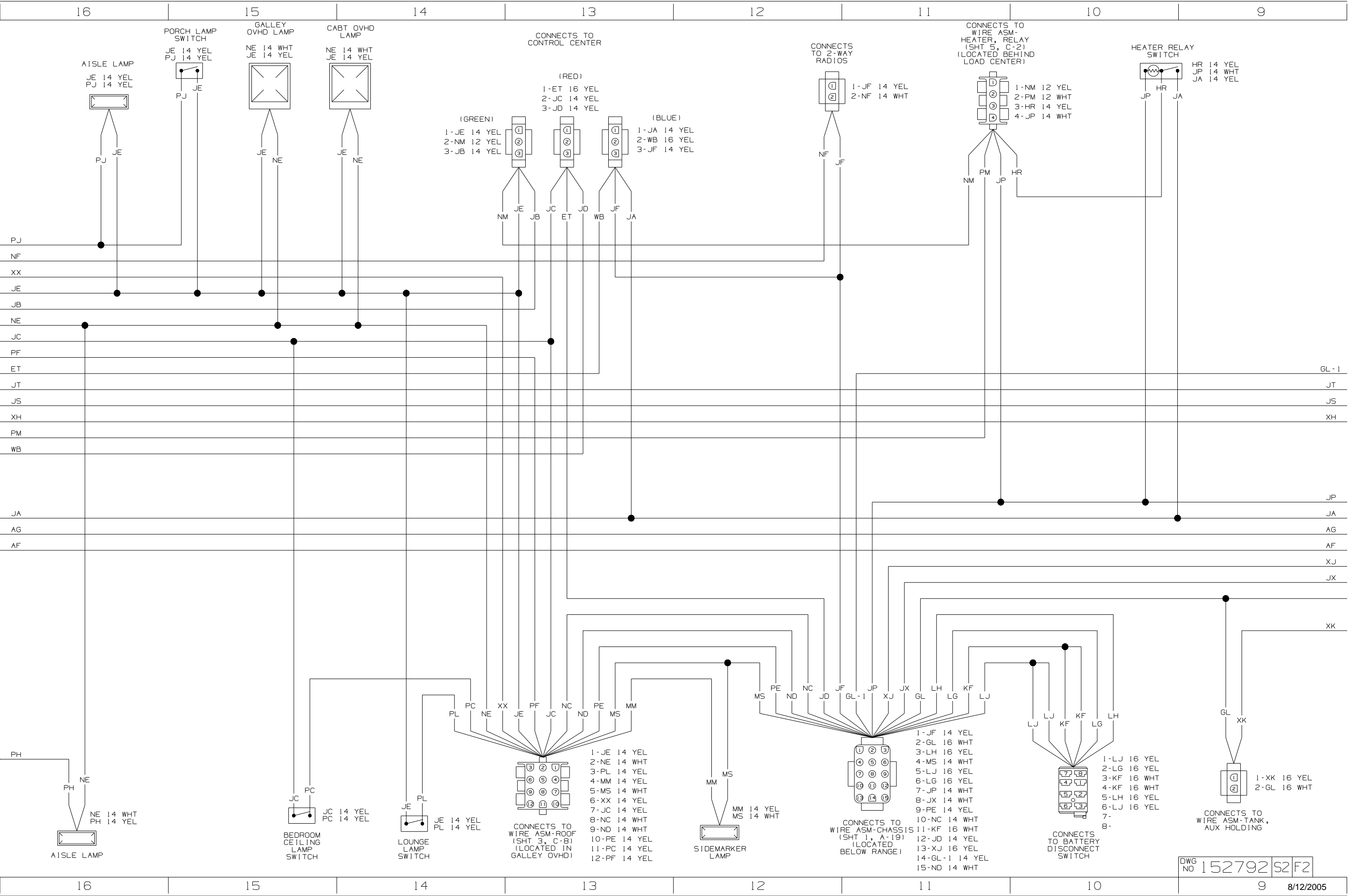

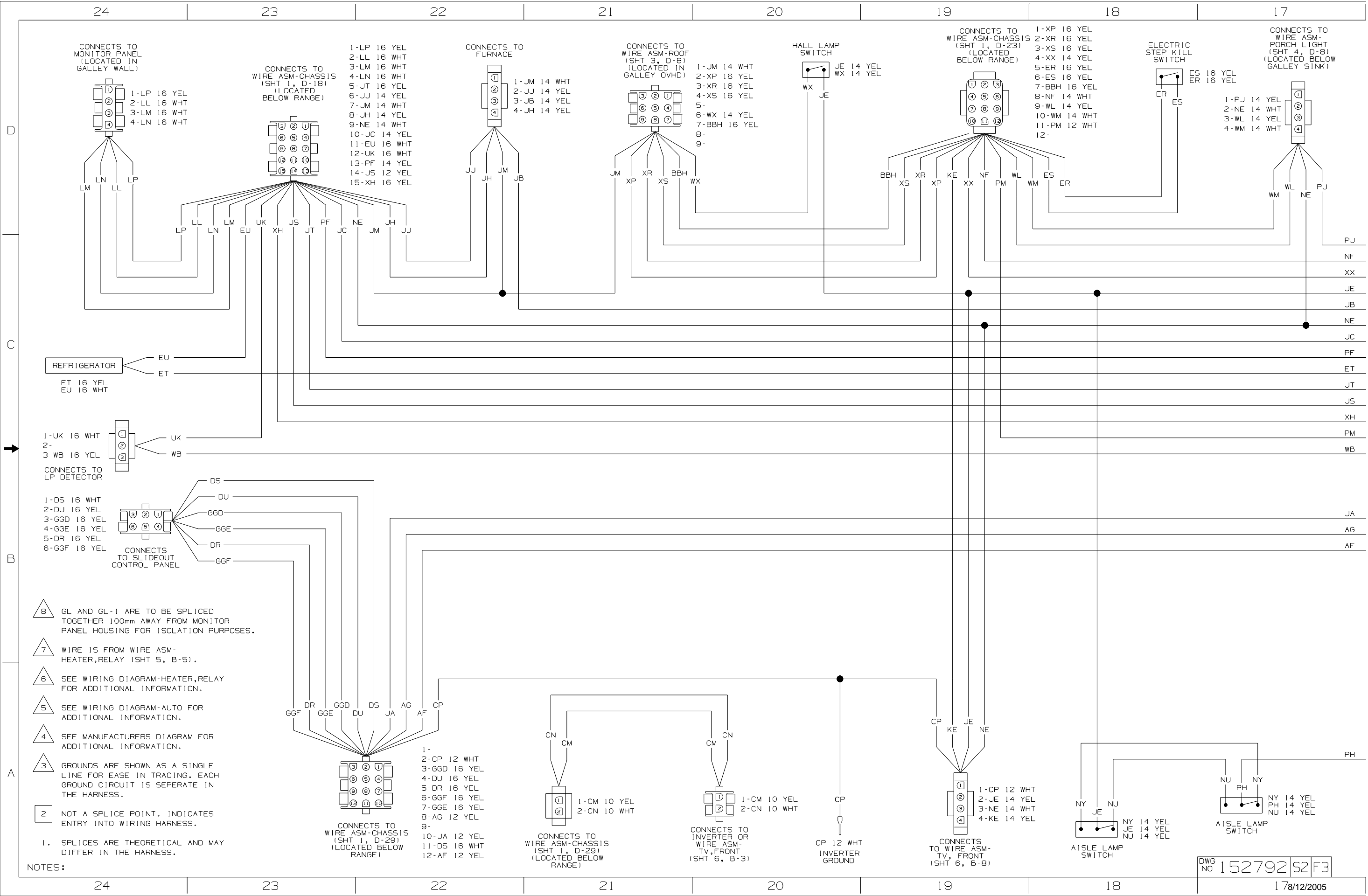

- NOTES:
- SPLICES ARE THEORETICAL AND MAY DIFFER IN THE HARNESS.
 - NOT A SPLICE POINT. INDICATES ENTRY INTO WIRING HARNESS.
 - GROUNDS ARE SHOWN AS A SINGLE LINE FOR EASE IN TRACING. EACH GROUND CIRCUIT IS SEPERATE IN THE HARNESS.
 - SEE MANUFACTURERS DIAGRAM FOR ADDITIONAL INFORMATION.
 - SEE WIRING DIAGRAM-AUTO FOR ADDITIONAL INFORMATION.
 - SEE WIRING DIAGRAM-HEATER,RELAY FOR ADDITIONAL INFORMATION.
 - WIRE IS FROM WIRE ASM-HEATER,RELAY (SHT 5, B-5).
 - GL AND GL-1 ARE TO BE SPLICED TOGETHER 100mm AWAY FROM MONITOR PANEL HOUSING FOR ISOLATION PURPOSES.

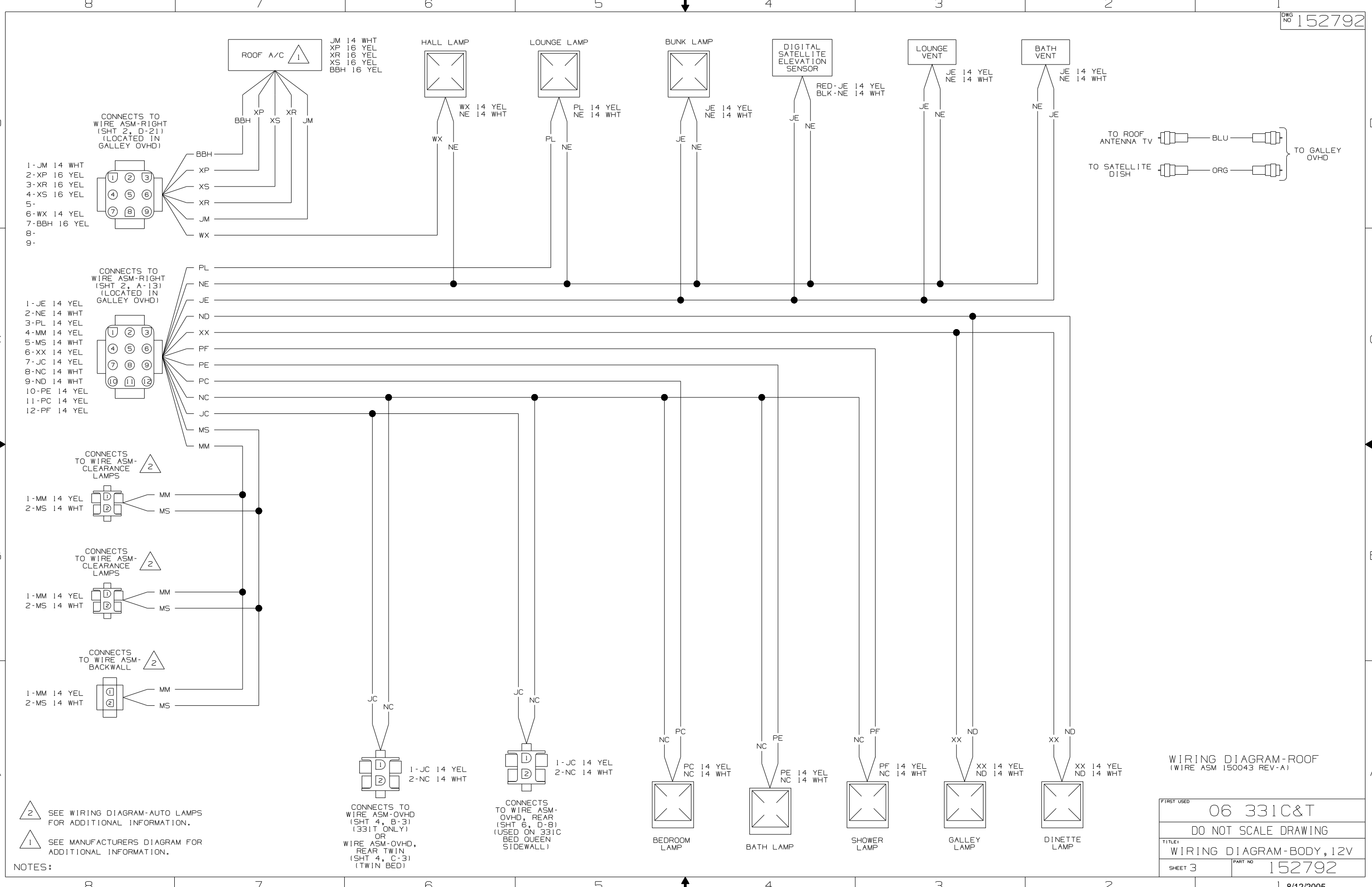

- 1-JM 14 WHT
- 2-XP 16 YEL
- 3-XR 16 YEL
- 4-XS 16 YEL
- 5-
- 6-WX 14 YEL
- 7-BBH 16 YEL
- 8-
- 9-

- 1-JE 14 YEL
- 2-NE 14 WHT
- 3-PL 14 YEL
- 4-MM 14 YEL
- 5-MS 14 WHT
- 6-XX 14 YEL
- 7-JC 14 YEL
- 8-NC 14 WHT
- 9-ND 14 WHT
- 10-PE 14 YEL
- 11-PC 14 YEL
- 12-PF 14 YEL

- 1-MM 14 YEL
- 2-MS 14 WHT

- 1-MM 14 YEL
- 2-MS 14 WHT

- 1-MM 14 YEL
- 2-MS 14 WHT

NOTES:

△ SEE WIRING DIAGRAM-AUTO LAMPS FOR ADDITIONAL INFORMATION.

① SEE MANUFACTURERS DIAGRAM FOR ADDITIONAL INFORMATION.

CONNECTS TO WIRE ASM-OVHD (SHT 4, B-3) (331T ONLY) OR WIRE ASM-OVHD, REAR TWIN (SHT 4, C-3) (TWIN BED)

CONNECTS TO WIRE ASM-OVHD, REAR (SHT 6, D-8) (USED ON 331C BED QUEEN SIDEWALL)

FIRST USED	06 331C&T
TITLE	DO NOT SCALE DRAWING
TITLE	WIRING DIAGRAM-BODY, 12V
SHEET 3	PART NO 152792
1 8/12/2005	

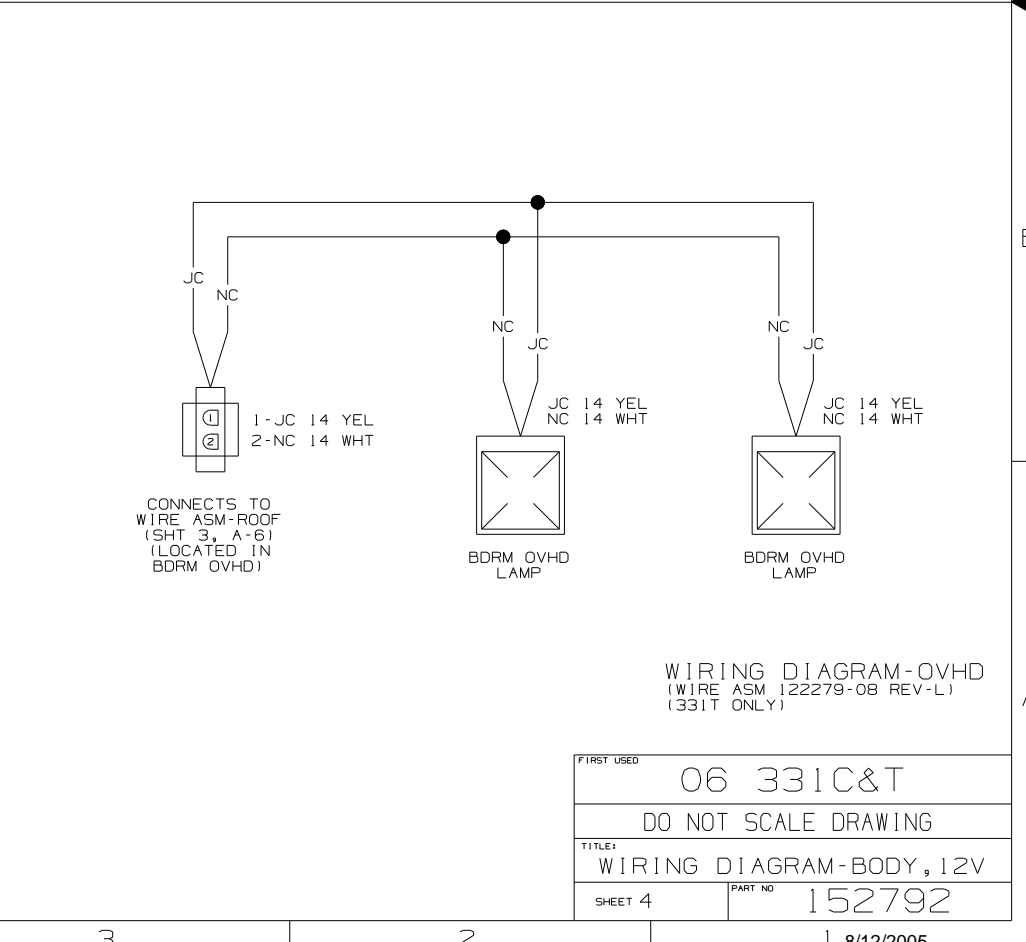
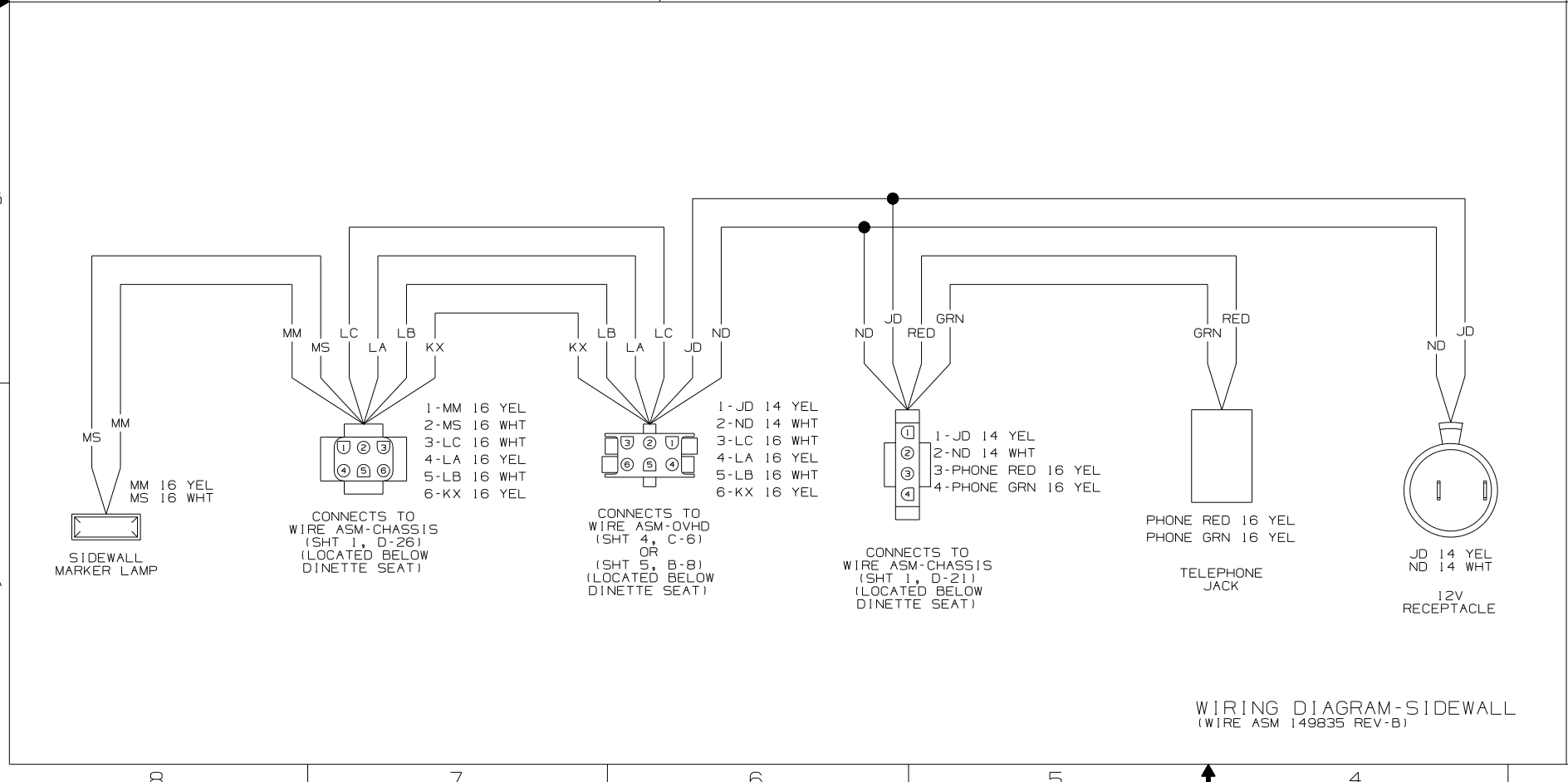
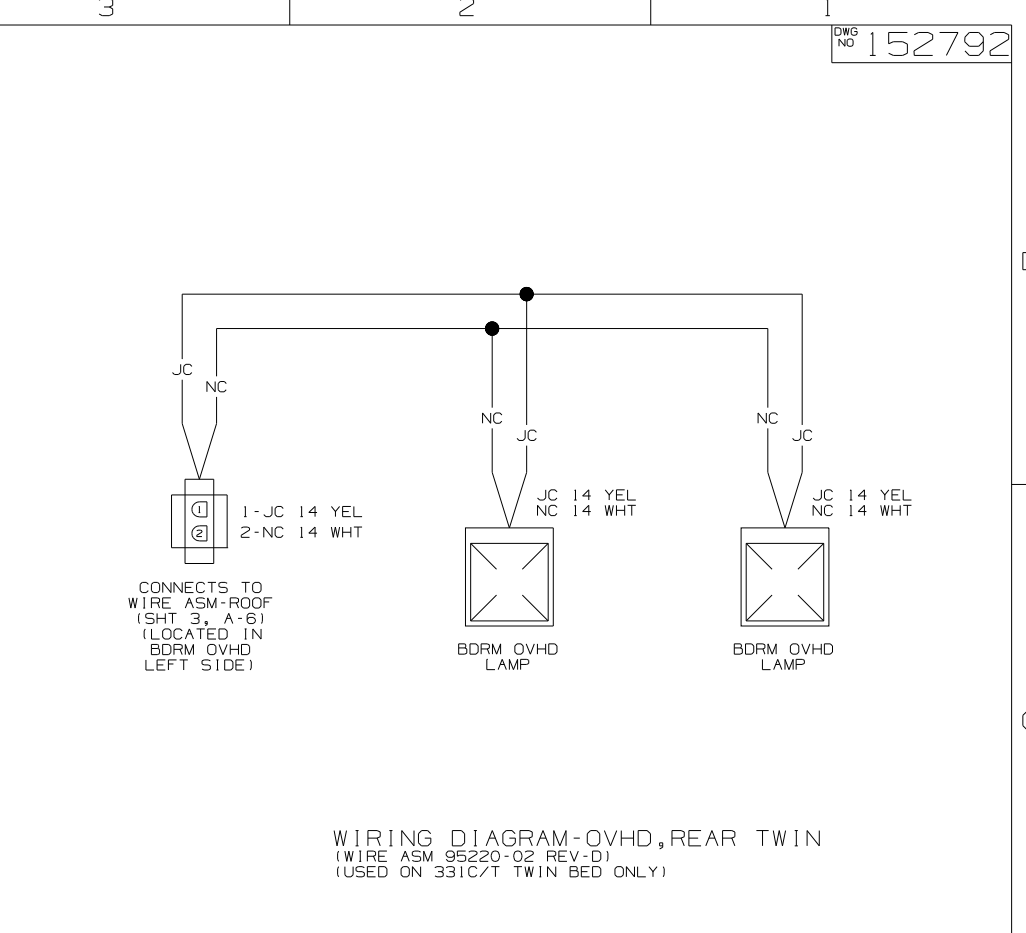
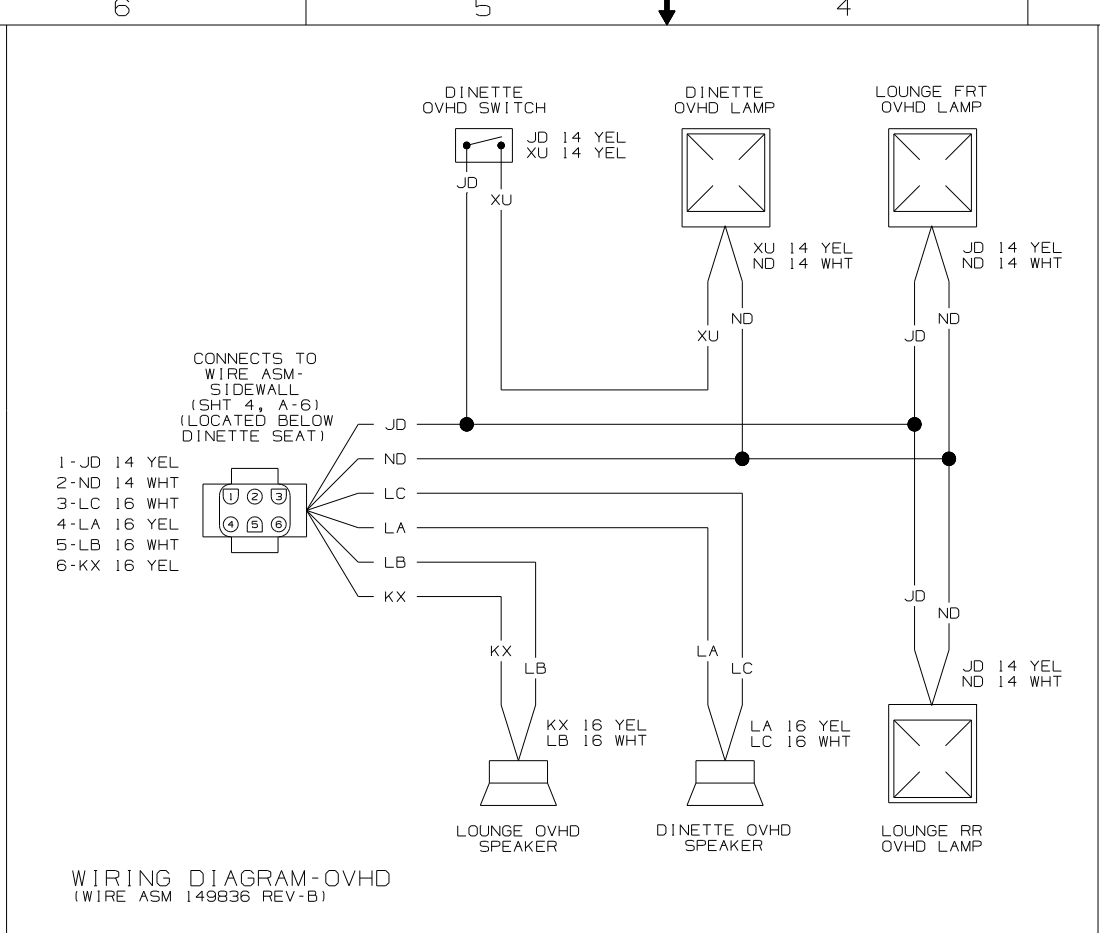
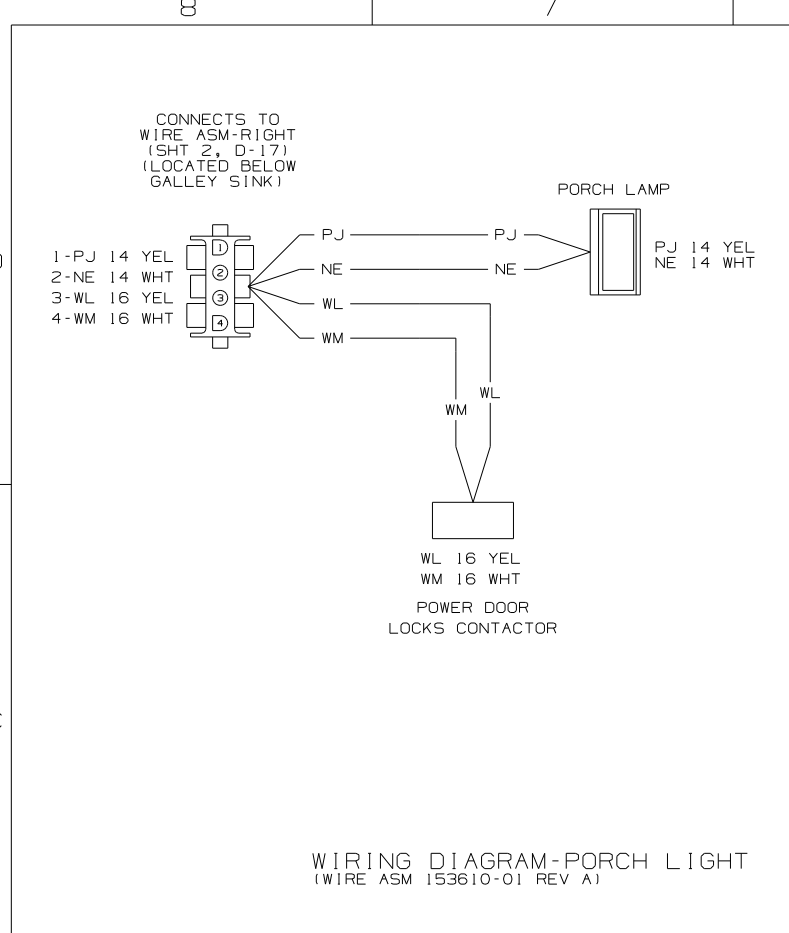

FIRST USED	06 331C&T
TITLE	DO NOT SCALE DRAWING
	WIRING DIAGRAM-BODY, 12V
SHEET 4	PART NO 152792

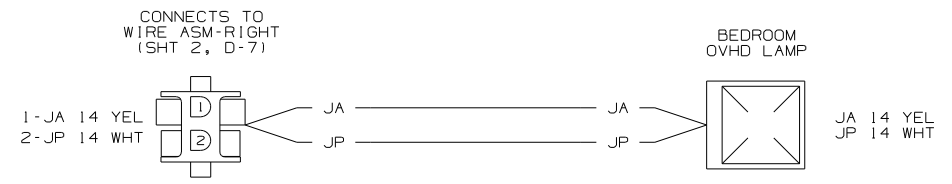

WIRING DIAGRAM-ROOF, CENTER
(WIRE ASM 77093-16 REV-AG)
(331T ONLY)

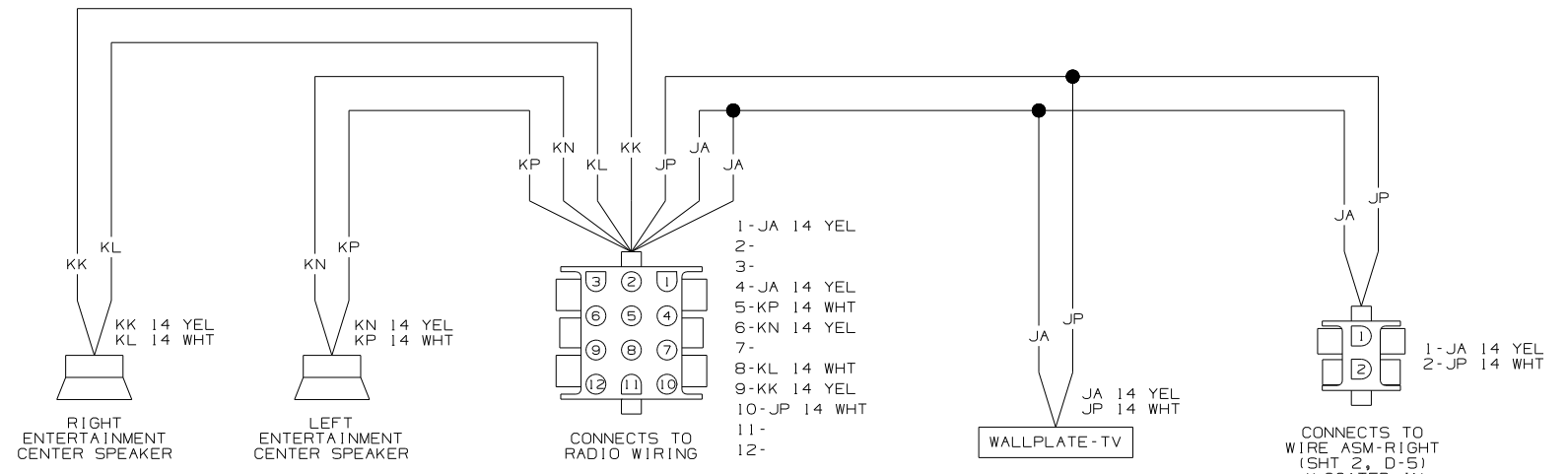

WIRING DIAGRAM-ENTERTAINMENT CTR
(WIRE ASM 125853-04 REV-L)

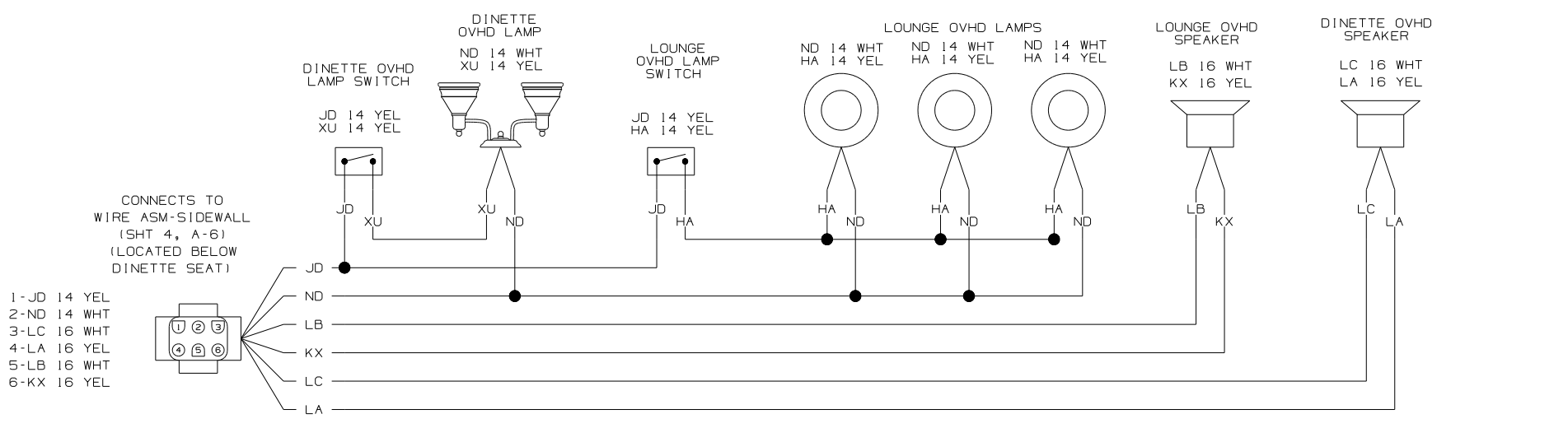

WIRING DIAGRAM-OVHD
(WIRE ASM 153432 REV-A)
(DELUXE FEATURE PKG)

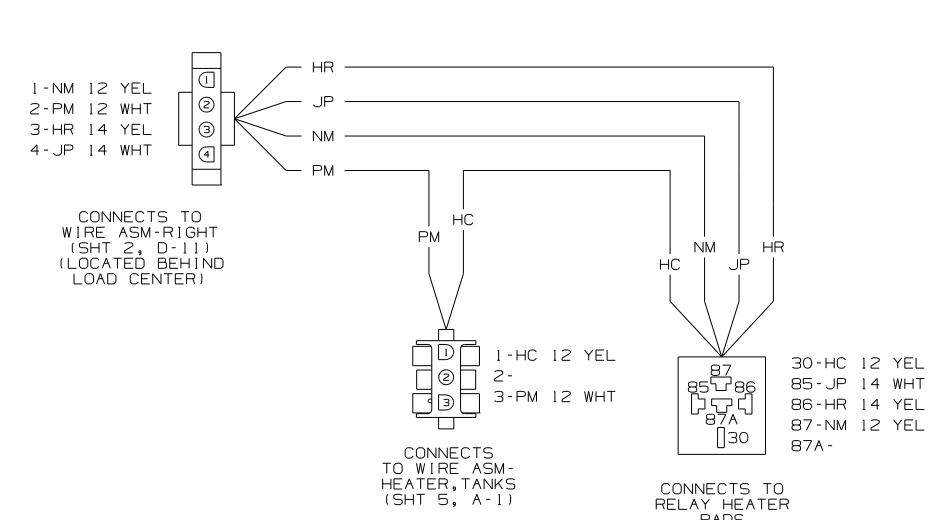

WIRING DIAGRAM-HEATER, RELAY
(WIRE ASM 153891 REV-A)

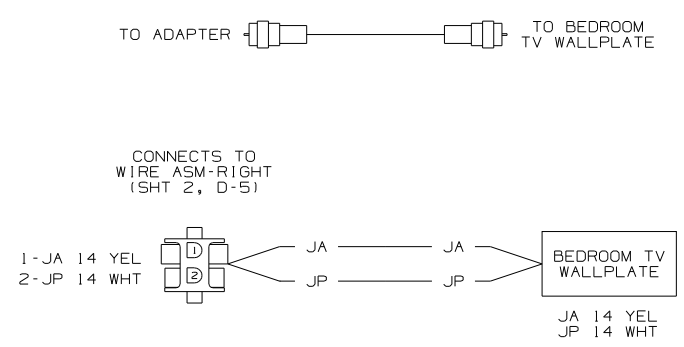

WIRING DIAGRAM-SIDEWALL
(WIRE ASM 111451-04 REV-N)
(USED WITH 331T BED QUEEN SIDEWALL)
(WIRE ASM 111451-08 REV-N)
(USED WITH 331C/T TWIN BED)
(WIRE ASM 111451-09 REV-N)
(USED WITH 331C BED QUEEN BACKWALL)

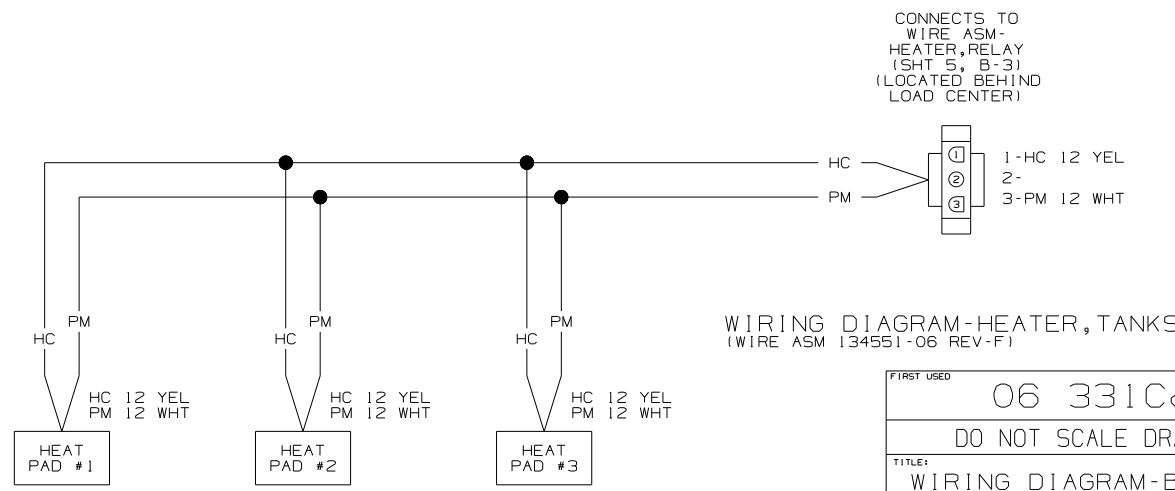

WIRING DIAGRAM-HEATER, TANKS
(WIRE ASM 134551-06 REV-F)

FIRST USED	06 331C&T
TITLE	DO NOT SCALE DRAWING
TITLE	WIRING DIAGRAM-BODY, 12V
SHEET 5	PART NO 152792

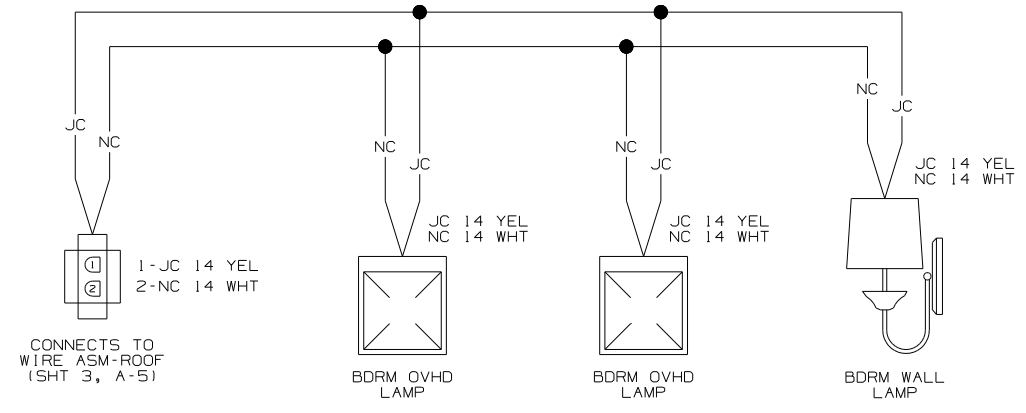

WIRING DIAGRAM-OVHD, REAR
(WIRE ASM 127873-03 REV-E)
(331C ONLY)

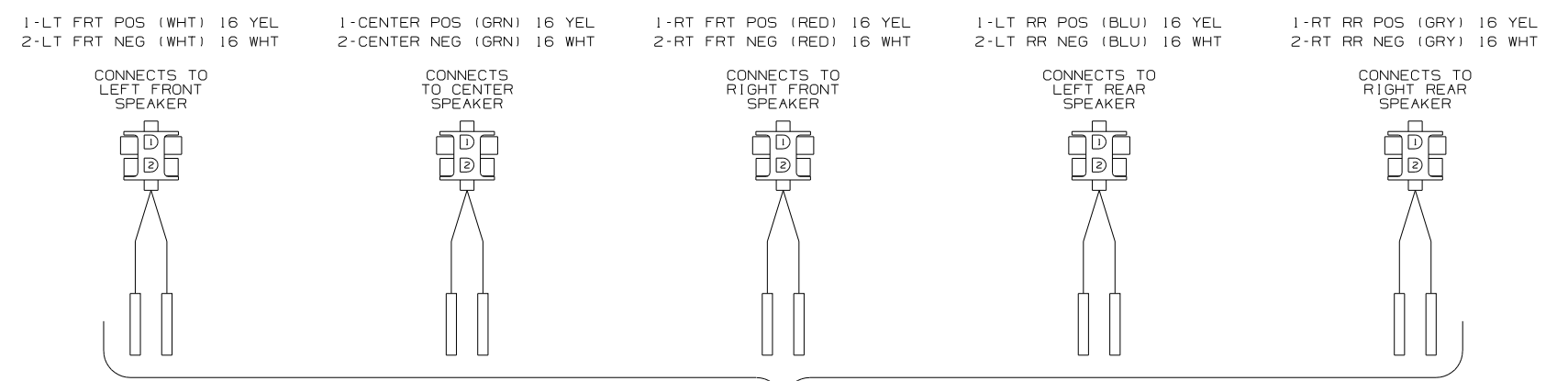

CONNECTS TO SPEAKER OUTPUTS ON HOME THEATER AMPLIFIER

RT FRT POS (RED) 16 YEL
RT FRT NEG (RED) 16 WHT
CENTER POS (GRN) 16 YEL
CENTER NEG (GRN) 16 WHT
LT FRT POS (WHT) 16 YEL
LT FRT NEG (WHT) 16 WHT
LT RR POS (BLU) 16 YEL
LT RR NEG (BLU) 16 WHT
RT RR POS (GRY) 16 YEL
RT RR NEG (GRY) 16 WHT

WIRING DIAGRAM-HOME THEATER EXTENSION
(WIRE ASM 148883-03 REV-H)

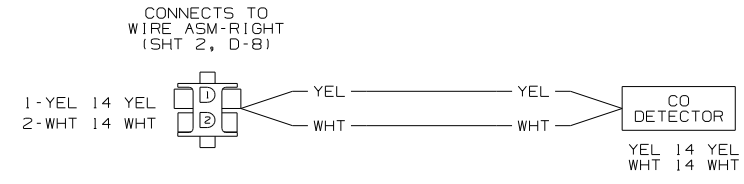

WIRING DIAGRAM-EXTENSION, 2 PIN
(WIRE ASM 149130 REV-B)

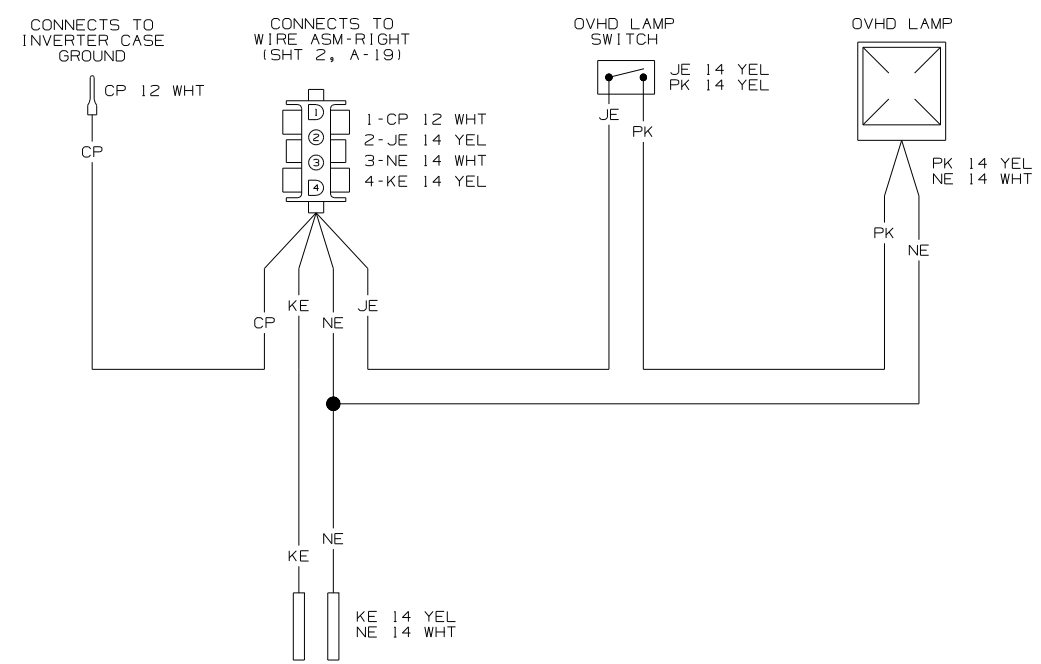

WIRING DIAGRAM-TV, FRONT
(WIRE ASM 148752-01 REV-E)

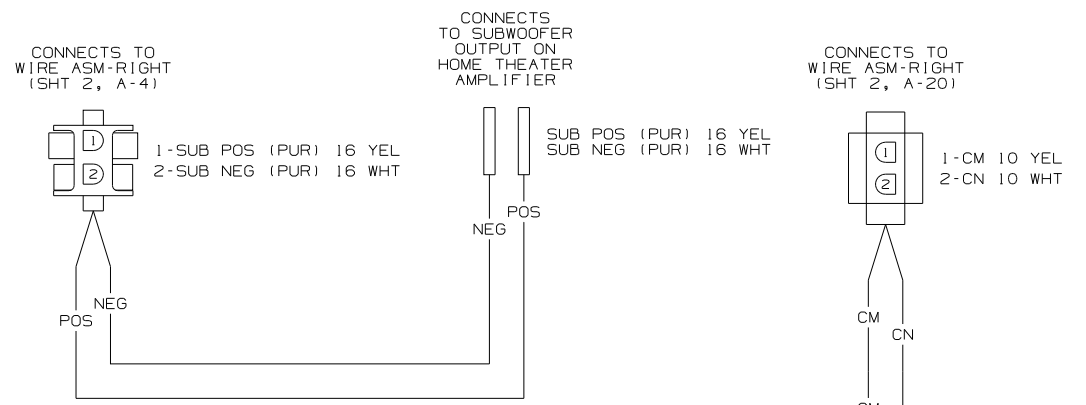

CONNECTS TO INVERTER

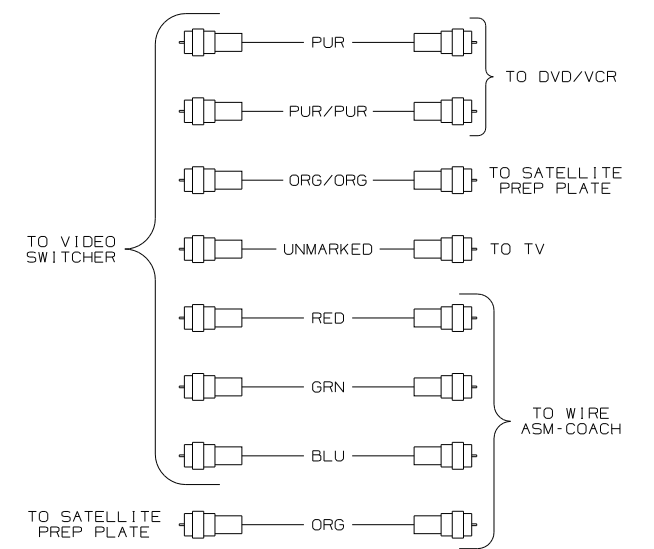

FIRST USED	06 331C&T
TITLE	DO NOT SCALE DRAWING
TITLE	WIRING DIAGRAM-BODY, 12V
SHEET 6	PART NO 152792

CONNECTS TO GENERATOR

- A-LN 16 WHT
- B-LM 16 WHT
- C-LL 16 WHT
- D-
- E-
- F-LP 16 YEL
- G-
- H-

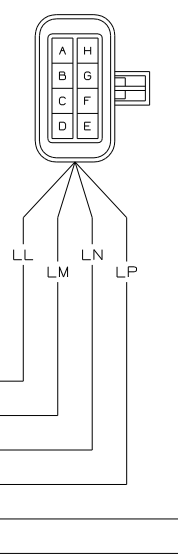

CONNECTS TO WIRE ASM-TANK, WATER

- 1-XH 16 YEL
- 2-GL 16 WHT

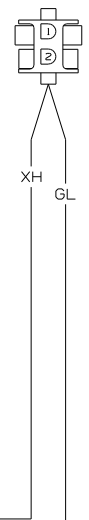

LP TANK

- JT 16 YEL
- MP 16 WHT



DOMELAMP

- CCU 16 YEL
- GE 16 YEL
- MU 14 WHT

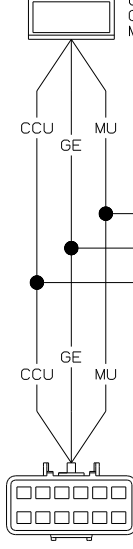

DOMELAMP

- CCU 16 YEL
- GE 16 YEL
- MU 14 WHT

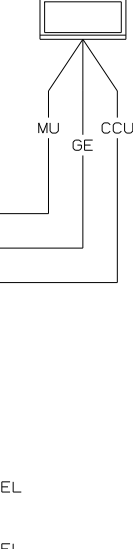

- A-
- B-
- C-MU 14 YEL
- D-
- E-
- F-GE 16 YEL
- G-CCU 16 YEL
- H-
- J-
- K-
- L-
- M-

CONNECTS TO CHEVY WIRING

CONNECTS TO CIRCUIT BREAKER COACH POWER (SHT 1, D-4)

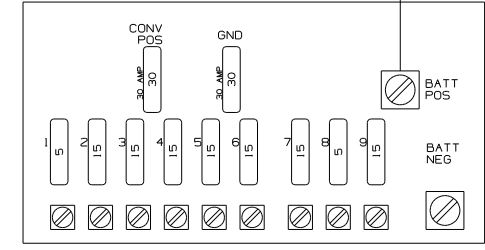
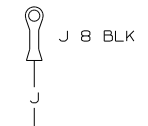

CONNECTS TO KWIKEE SLIDEOUT CONTROLLER (#1 ACTUATOR DRIVE LEAD)

- 1-AAY 12 YEL
- 2-AAZ 12 YEL

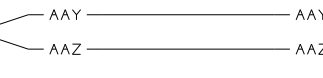

CONNECTS TO SLIDEOUT ACTUATOR #1

- A-AAY 12 YEL
- B-AAZ 12 YEL

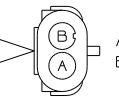

CONNECTS TO KWIKEE SLIDEOUT CONTROLLER (#2 ACTUATOR DRIVE LEAD)

- 1-GGN 12 YEL
- 2-GGP 12 YEL

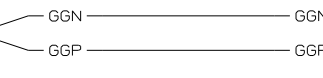

CONNECTS TO SLIDEOUT ACTUATOR #2

- A-GGN 12 YEL
- B-GGP 12 YEL

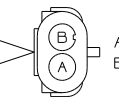

CONNECTS TO REAR VIEW MONITOR CAMERA



CONNECTS TO REAR VIEW MONITOR



REAR MONITOR CABLE

CONNECTS TO SLIDEOUT ACTUATOR #1

- A-GGG 16 YEL
- B-GGJ 16 WHT
- C-GGH 16 YEL

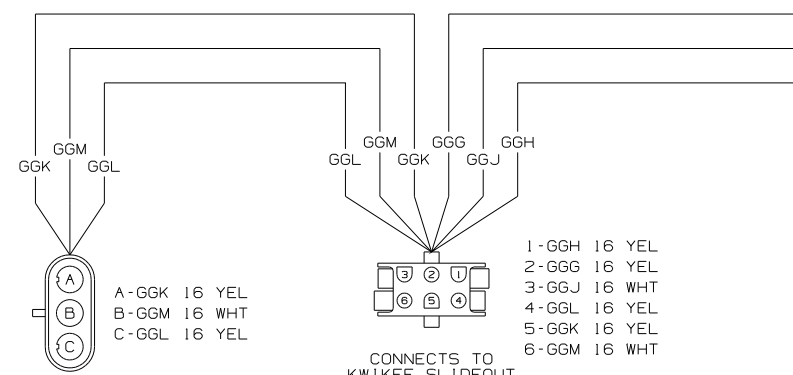
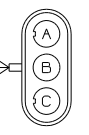

- 1-GGH 16 YEL
- 2-GGG 16 YEL
- 3-GGJ 16 WHT
- 4-GGL 16 YEL
- 5-GGK 16 YEL
- 6-GGM 16 WHT

CONNECTS TO KWIKEE SLIDEOUT CONTROLLER (ENCODER FEED)

CONNECTS TO SLIDEOUT ACTUATOR #2

- A-GGK 16 YEL
- B-GGM 16 WHT
- C-GGL 16 YEL

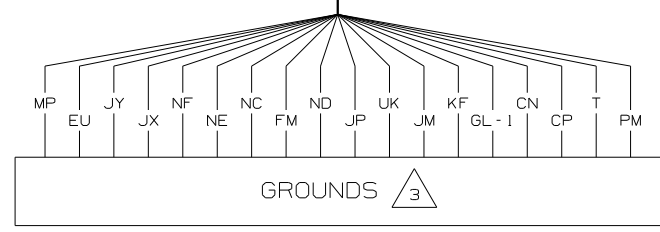
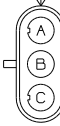

- NF 14 WHT
- JP 14 WHT
- UK 16 WHT
- JM 14 WHT
- KF 16 WHT
- PM 12 WHT
- EU 16 WHT
- JY 12 WHT
- JX 14 WHT
- NE 14 WHT
- NC 14 WHT
- FM 14 WHT
- ND 14 WHT
- JP 16 WHT
- UK 14 WHT
- JM 14 WHT
- KF 14 WHT
- GL-1 14 WHT
- CN 10 WHT
- CP 12 WHT
- T 10 WHT

WIRING DIAGRAM-CHASSIS,GM (WIRE ASM 155660 REV-H)

FIRST USED	06 331C&T
TITLE	DO NOT SCALE DRAWING
TITLE	WIRING DIAGRAM-BODY, 12V
SHEET 7	PART NO 152792

F1

