



**DANGER**

**Danger of electrical shock, burns or death.** Always remove all power sources before attempting any repair, service or diagnostic work. Power can be present from shore power, generator, inverter or battery. All power sources must be disabled and secured before performing any service.



**CAUTION**

If you lack the skills, tools or equipment to perform diagnostic or repair work leave such work to an authorized Winnebago Industries dealer or other qualified shop.

DRAWING NO.	FEATURE
152746-01	(WIN)
152746-02	(ITA)

RELEASE	REV/DATE	DWG NO	152746
REV ZONE	REVISION RECORD	DATE	DFTR-ORIG

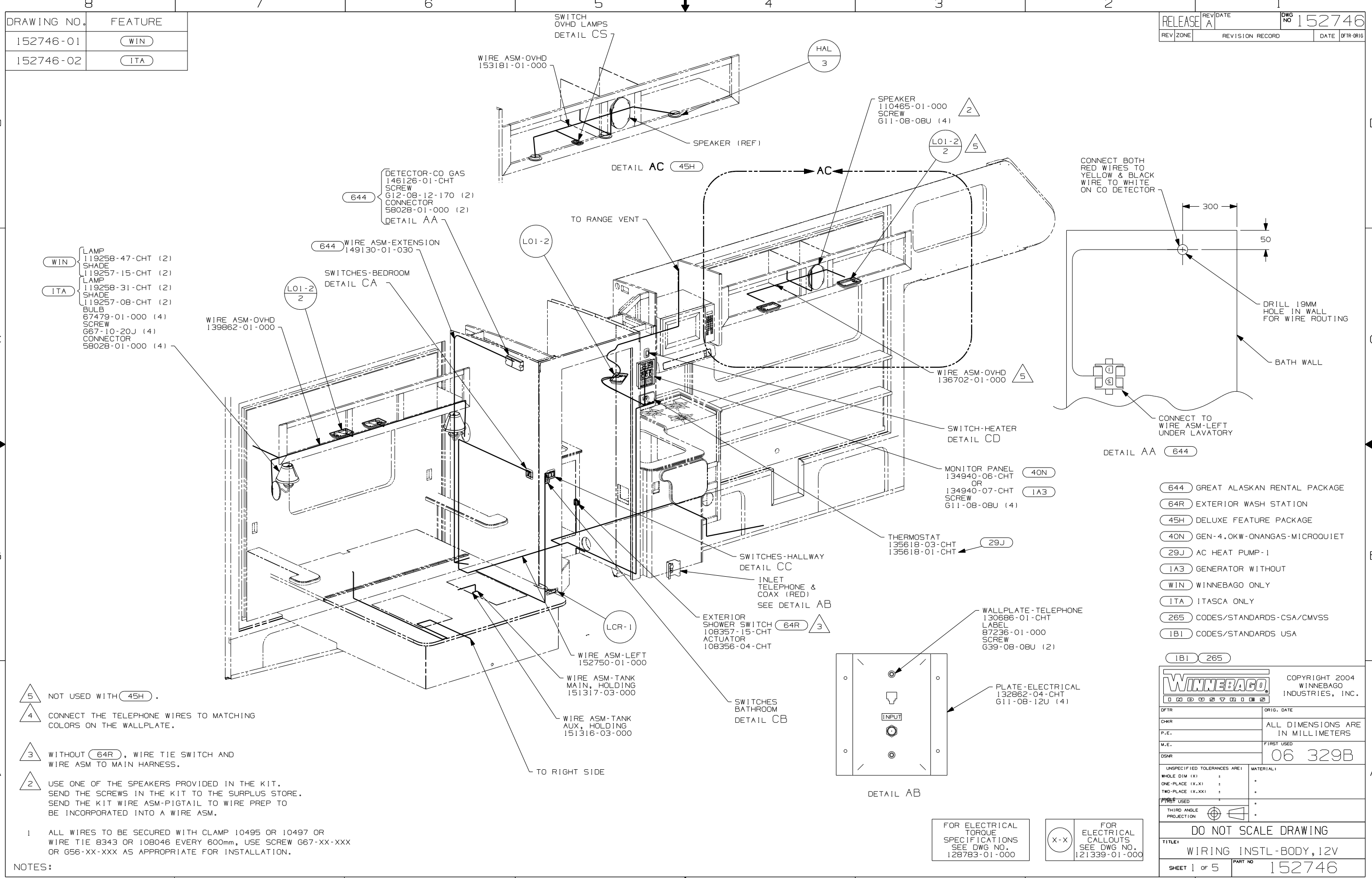

- (WIN) LAMP 119258-47-CHT (2)
- (WIN) SHADE 119257-15-CHT (2)
- (ITA) LAMP 119258-31-CHT (2)
- (ITA) SHADE 119257-08-CHT (2)
- (ITA) BULB 67479-01-000 (4)
- (ITA) SCREW 667-10-20J (4)
- (ITA) CONNECTOR 58028-01-000 (4)

- 5 NOT USED WITH (45H).
- 4 CONNECT THE TELEPHONE WIRES TO MATCHING COLORS ON THE WALLPLATE.
- 3 WITHOUT (64R), WIRE TIE SWITCH AND WIRE ASM TO MAIN HARNESS.
- 2 USE ONE OF THE SPEAKERS PROVIDED IN THE KIT. SEND THE SCREWS IN THE KIT TO THE SURPLUS STORE. SEND THE KIT WIRE ASM-PIGTAIL TO WIRE PREP TO BE INCORPORATED INTO A WIRE ASM.

1 ALL WIRES TO BE SECURED WITH CLAMP 10495 OR 10497 OR WIRE TIE 8343 OR 108046 EVERY 600mm, USE SCREW G67-XX-XXX OR G56-XX-XXX AS APPROPRIATE FOR INSTALLATION.

NOTES:

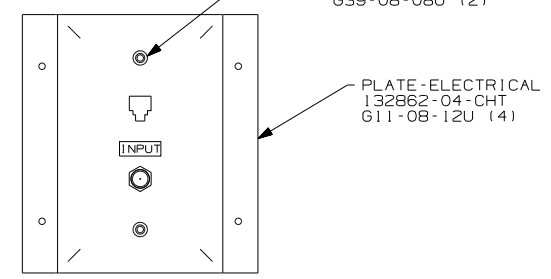
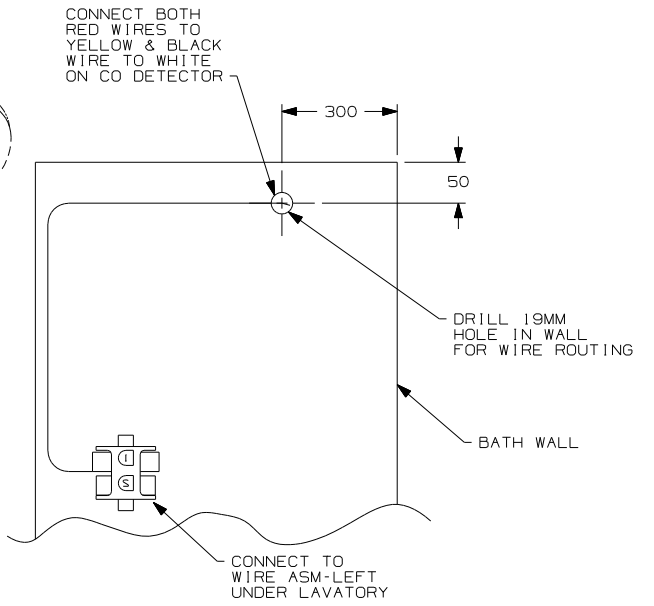

- (644) GREAT ALASKAN RENTAL PACKAGE
- (64R) EXTERIOR WASH STATION
- (45H) DELUXE FEATURE PACKAGE
- (40N) GEN-4.0KW-ONANGAS-MICROQUIET
- (29J) AC HEAT PUMP-1
- (1A3) GENERATOR WITHOUT
- (WIN) WINNEBAGO ONLY
- (ITA) ITASCA ONLY
- (265) CODES/STANDARDS-CSA/CMVSS
- (1B1) CODES/STANDARDS USA

**WINNEBAGO** COPYRIGHT 2004 WINNEBAGO INDUSTRIES, INC.

DFTR	ORIG. DATE
CHKR	ALL DIMENSIONS ARE IN MILLIMETERS
P.E.	
M.E.	FIRST USED
DSNR	06 329B

UNSPECIFIED TOLERANCES ARE: MATERIAL:

HOLE DIM (X)	:	*
ONE-PLACE (X.X)	:	*
TWO-PLACE (X.XX)	:	*
FIRST USED	:	*
THIRD ANGLE PROJECTION	:	*

**DO NOT SCALE DRAWING**

TITLE: WIRING INSTL-BODY, 12V

SHEET 1 OF 5 PART NO 152746

REF: 1 10/17/2005

FOR ELECTRICAL TORQUE SPECIFICATIONS SEE DWG NO. 128783-01-000

(X-X) FOR ELECTRICAL CALLOUTS SEE DWG NO. 121339-01-000



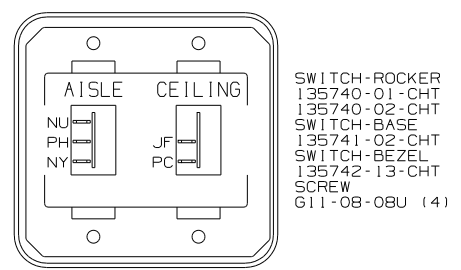

SWITCH-ROCKER  
135740-01-CHT  
135740-02-CHT  
SWITCH-BASE  
135741-01-CHT  
SWITCH-BEZEL  
135742-13-CHT  
SCREW  
G11-08-08U (4)

DETAIL CA

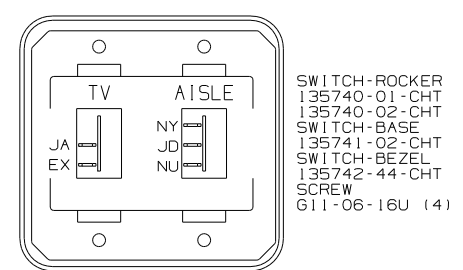

SWITCH-ROCKER  
135740-01-CHT  
135740-02-CHT  
SWITCH-BASE  
135741-01-CHT  
SWITCH-BEZEL  
135742-44-CHT  
SCREW  
G11-06-16U (4)

DETAIL CE (1JR) 1

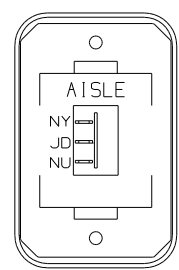

SWITCH-ROCKER  
135740-02-CHT  
SWITCH-BASE  
135741-01-CHT  
SWITCH-BEZEL  
135742-06-CHT  
SCREW  
G11-08-08U (2)

DETAIL CE (42J) 3

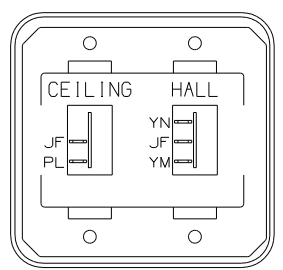

SWITCH-ROCKER  
135740-01-CHT  
135740-02-CHT  
SWITCH-BASE  
135741-02-CHT  
SWITCH-BEZEL  
135742-16-CHT  
SCREW  
G11-08-08U (4)

DETAIL CJ

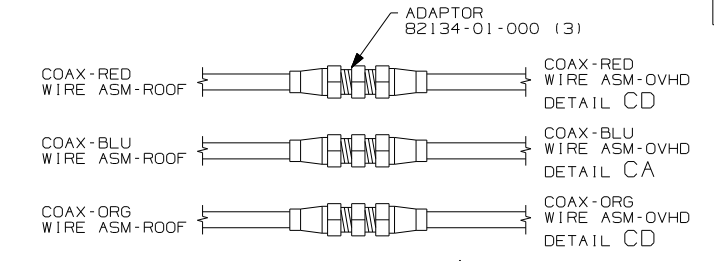

DETAIL CN (1JR) 1

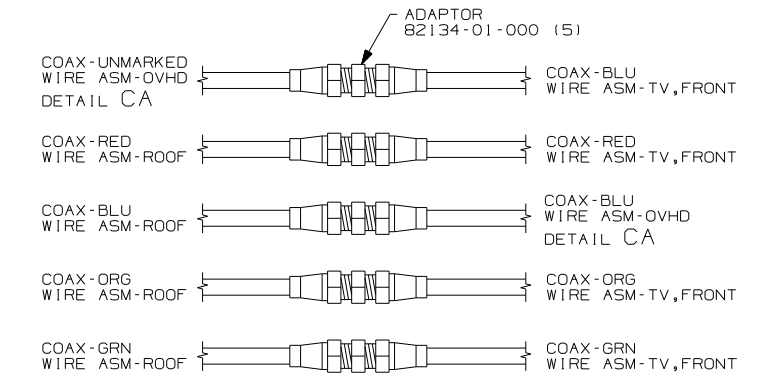

DETAIL CN (42J) 3

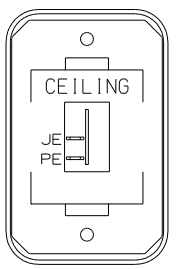

SWITCH-ROCKER  
135740-01-CHT  
SWITCH-BASE  
135741-01-CHT  
SWITCH-BEZEL  
135742-07-CHT  
SCREW  
G11-08-08U (2)

DETAIL CB

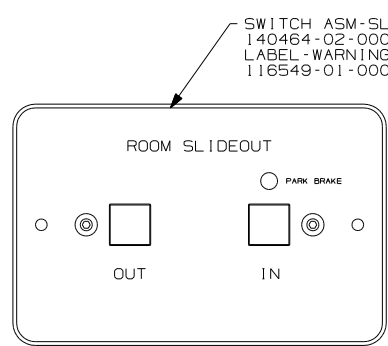

**WARNING** UNDERSTAND OPERATOR'S MANUAL BEFORE USING. KEEP PEOPLE AND OBSTRUCTIONS CLEAR OF SLIDEOUT ROOM WHEN OPERATING TO AVOID INJURY AND/OR PROPERTY DAMAGE.

DETAIL CF

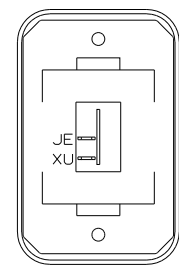

SWITCH-ROCKER  
135740-01-CHT  
SWITCH-BASE  
135741-01-CHT  
SWITCH-BEZEL  
135742-01-CHT  
SCREW  
G11-08-08U (2)

DETAIL CK

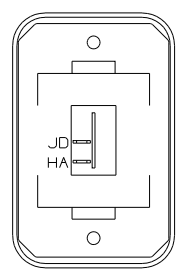

SWITCH-ROCKER  
135740-01-CHT  
SWITCH-BASE  
135741-01-CHT  
SWITCH-BEZEL  
135742-01-CHT  
SCREW  
G11-08-08U (2)

DETAIL CS (45H)

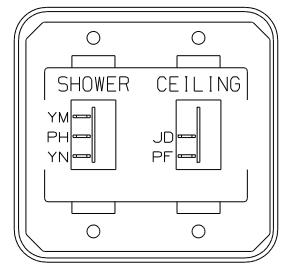

SWITCH-ROCKER  
135740-01-CHT  
135740-02-CHT  
SWITCH-BASE  
135741-02-CHT  
SWITCH-BEZEL  
135742-15-CHT  
SCREW  
G11-08-08U (4)

DETAIL CC

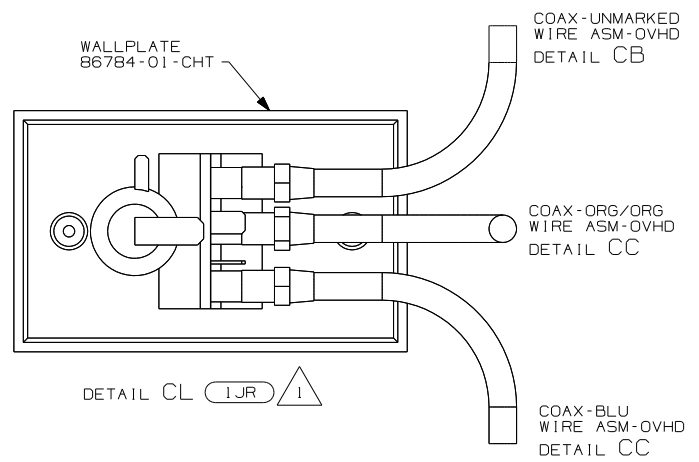

DETAIL CL (1JR) 1

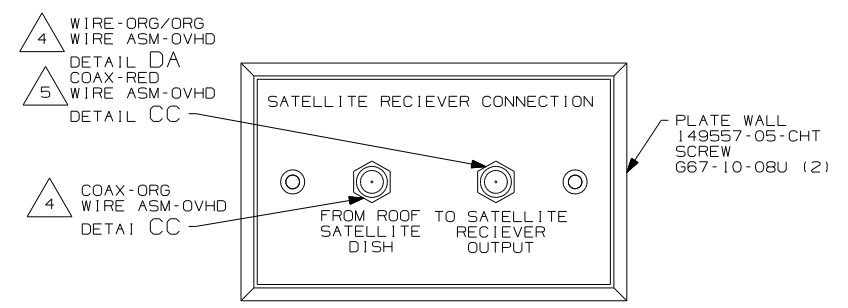

DETAIL CP (1JR) 1

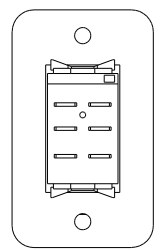

SWITCH-BATTERY,DISC  
108357-06-000  
ACTUATOR-SWITCH  
108356-11-CHT  
PLATE-SWITCH  
98351-07-CHT  
SCREW  
G11-06-10U (2)

DETAIL CG

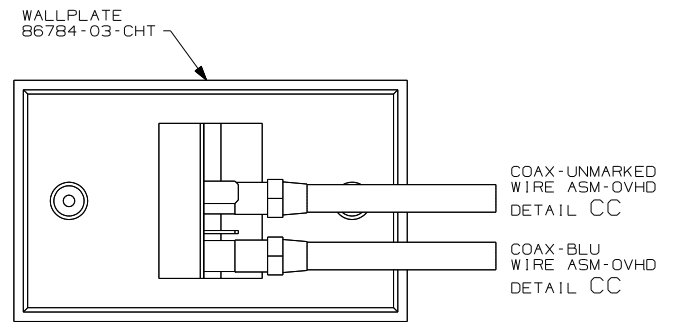

DETAIL CL (42J) 3

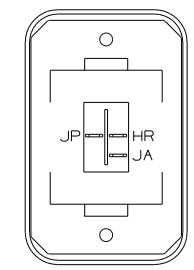

SWITCH-ROCKER  
135740-06-CHT  
SWITCH-BASE  
135741-01-CHT  
SWITCH-BEZEL  
135742-01-CHT  
SCREW  
G11-08-08U (2)

DETAIL CD (23T)

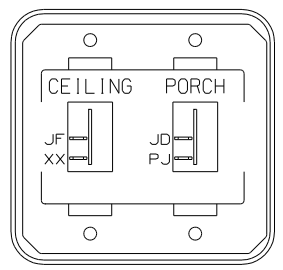

SWITCH-ROCKER  
135740-01-CHT  
SWITCH-BASE  
135741-02-CHT  
SWITCH-BEZEL  
135742-19-CHT  
SCREW  
G11-08-08U (4)

DETAIL CH

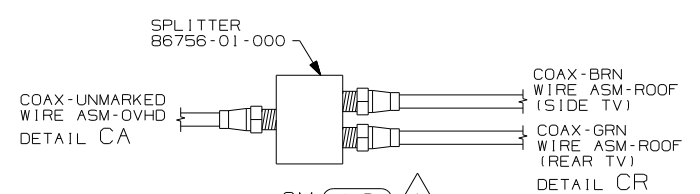

DETAIL CM (1JR) 1

- NOTES:
- 5 CONNECT COAX TO FRONT SIDE OF WALL PLATE.
  - 4 CONNECT COAX TO BACK SIDE OF WALLPLATE.
  - 3 NOT USED WITH (1JR)
  - 2 WITHOUT (1D5) USE ADAPTOR TO CONNECT GRN COAX FROM WIRE ASM-ROOF TO GRN COAX FROM WIRE ASM-RIGHT.
  - 1 NOT USED WITH (42J)

- (45H) DELUXE FEATURE PACKAGE
- (42J) TV-24" COLOR,STEREO W/REMOTE
- (23T) DRAINAGE SYSTEM-HEATED
- (1JR) TV-13" W/DVD-12V
- (1E2) ENTRANCE STEP-ELEC.
- (1D5) ENTERTAINMENT CENTR/EXT W/CD

FIRST USED	06 329B
DO NOT SCALE DRAWING	
TITLE:	WIRING INSTL-BODY,12V
SHEET 3	PART NO 152746

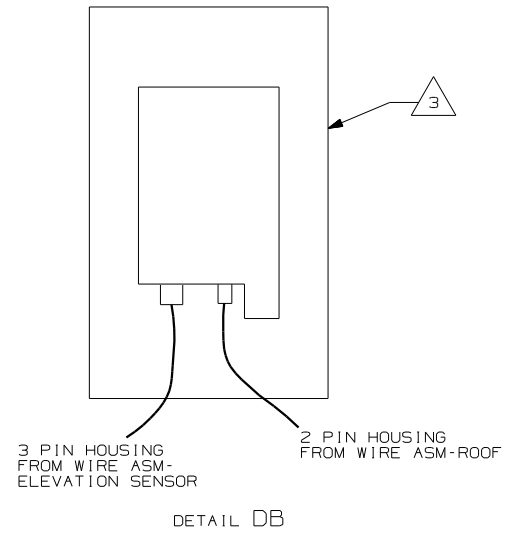
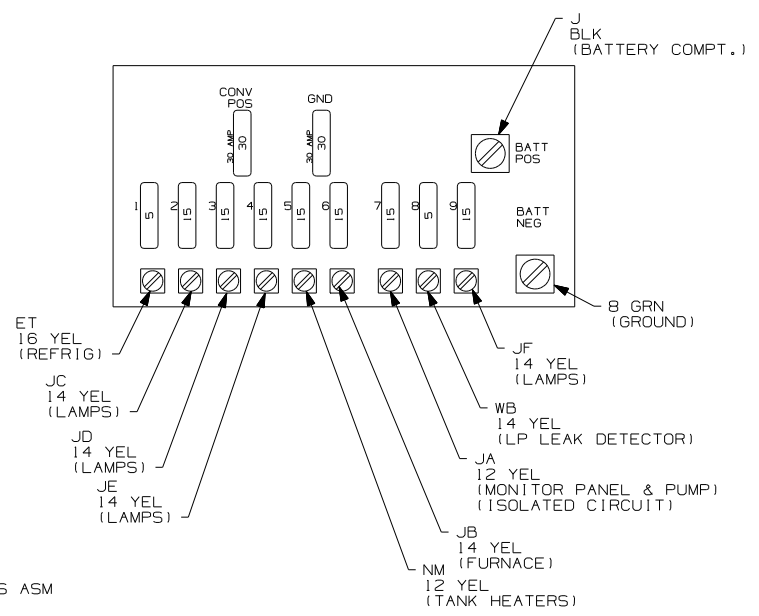
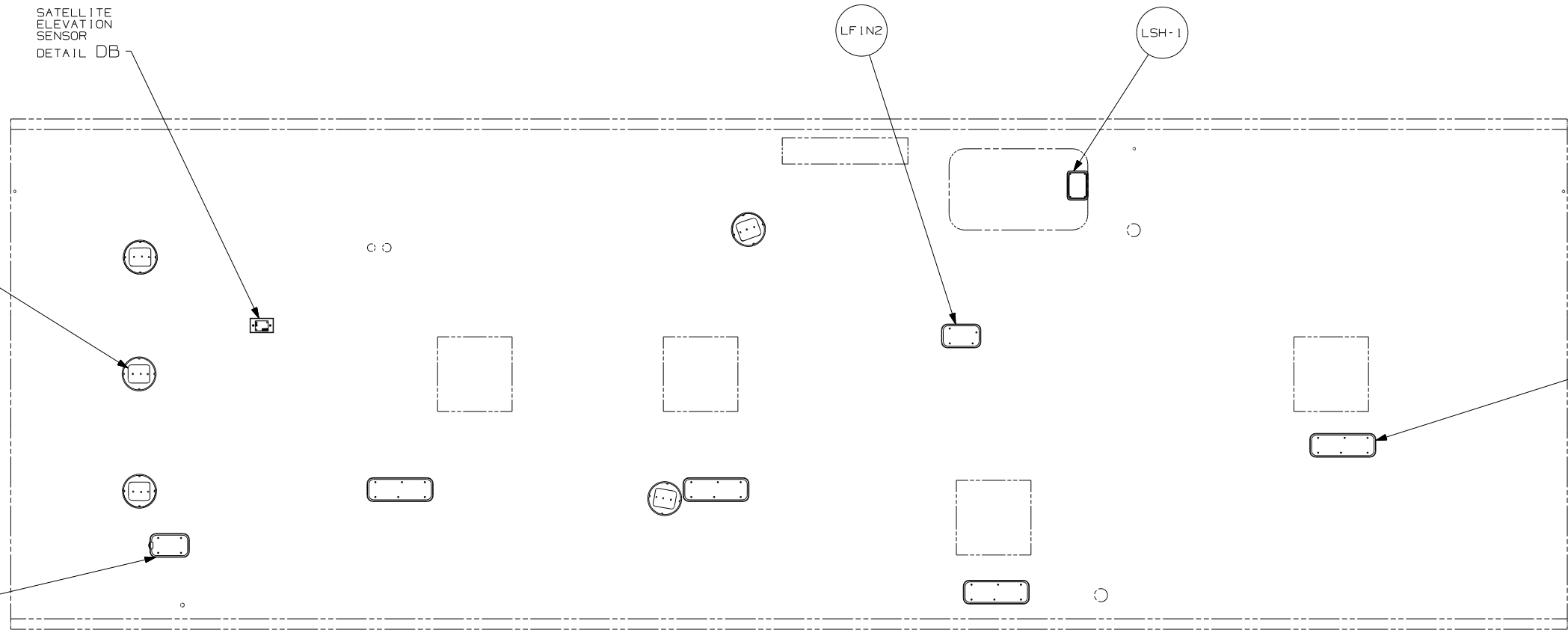

- (42J) TV-24" COLOR, STEREO W/REMOTE
- (23T) DRAINAGE SYSTEM-HEATED
- (1JM) HOME THEATER SOUND SYSTEM

- △ 4 FOR REFERENCE ONLY. SEE LOAD CENTER/ATS ASM FOR ADDITIONAL INFORMATION.
- △ 3 SENSOR SUPPLIED WITH SATELLITE ASSEMBLY.
- △ 2 NOT USED WITH (42J).

NOTES:  
1. SEE ROOF ASSEMBLY FOR ADDITIONAL INFORMATION.

FOR ELECTRICAL TORQUE SPECIFICATIONS SEE DWG NO. 128783-01-000

(X-X) FOR ELECTRICAL CALLOUTS SEE DWG NO. 121339-01-000

FIRST USED	06 329B
DO NOT SCALE DRAWING	
TITLE:	WIRING INSTL-BODY, 12V
SHEET 4	PART NO 152746

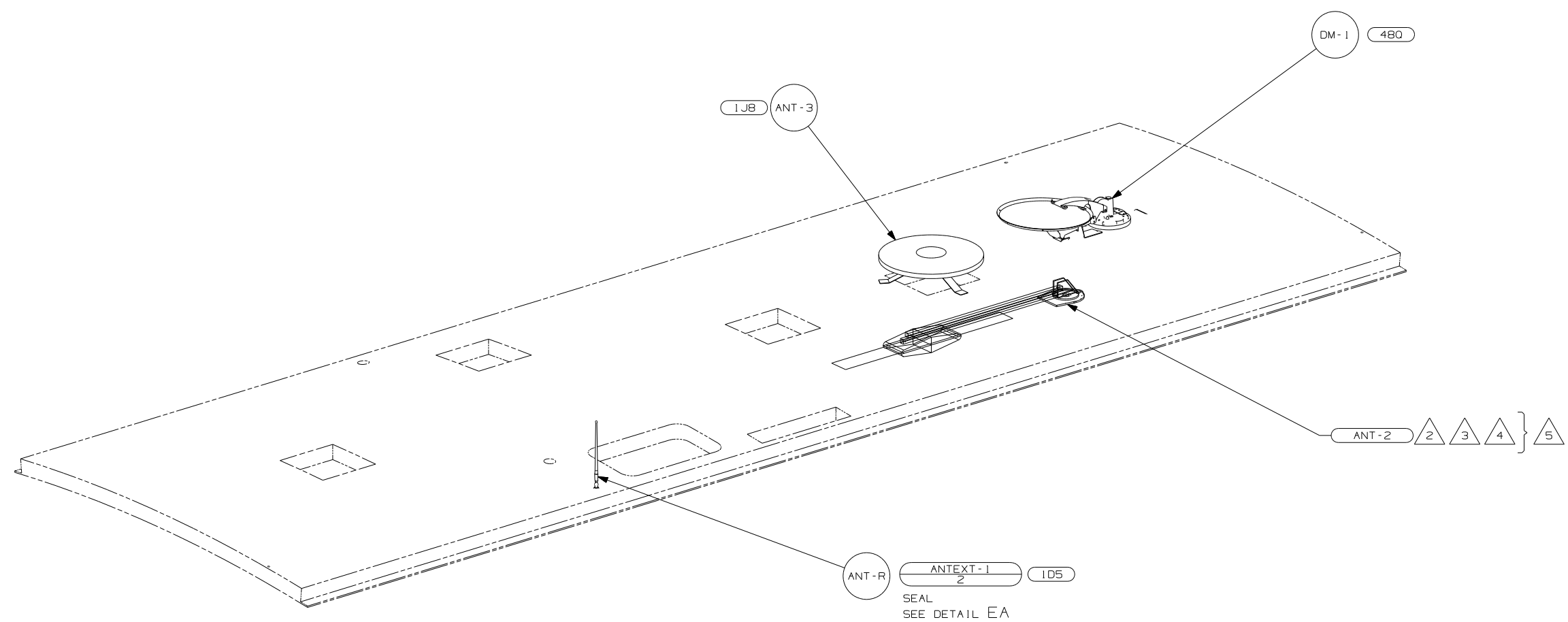

- NOTES:
- 5 NOT USED WITH 1JB.
  - 4 ADD RUBBER BUMPER TO ROOF UNDER EACH END OF ANTENNA WHICH MAY COME INTO CONTACT WITH ROOF IN DOWN POSITION.
  - 3 LOCATE CLAMP TO RETAIN CABLE BUT NOT TO RESTRICT ANTENNA TRAVEL.
  - 2 SEE DRAWING 76319-01-000 FOR INSTALLATION OF TV ANTENNA.
  - 1 WRAP BRACKET LEGS AROUND ANTENNA BASE.

- 4B0 SATELLITE DISH
- 1JB TV ANTENNA-OMNI DIRECTIONAL
- 1D5 ENTERTAINMENT CENTR/EXT W/CD

FOR ELECTRICAL TORQUE SPECIFICATIONS SEE DWG NO. 128783-01-000

FOR ELECTRICAL CALLOUTS SEE DWG NO. 121339-01-000

FIRST USED	06 329B
DO NOT SCALE DRAWING	
TITLE	WIRING INSTL-BODY, 12V
SHEET 5	PART NO 152746