



**DANGER**

**Danger of electrical shock, burns or death.** Always remove all power sources before attempting any repair, service or diagnostic work. Power can be present from shore power, generator, inverter or battery. All power sources must be disabled and secured before performing any service.



**CAUTION**

If you lack the skills, tools or equipment to perform diagnostic or repair work leave such work to an authorized Winnebago Industries dealer or other qualified shop.



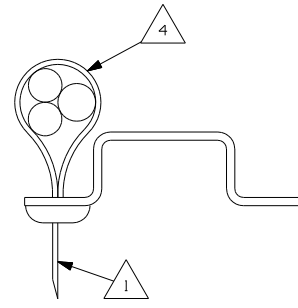
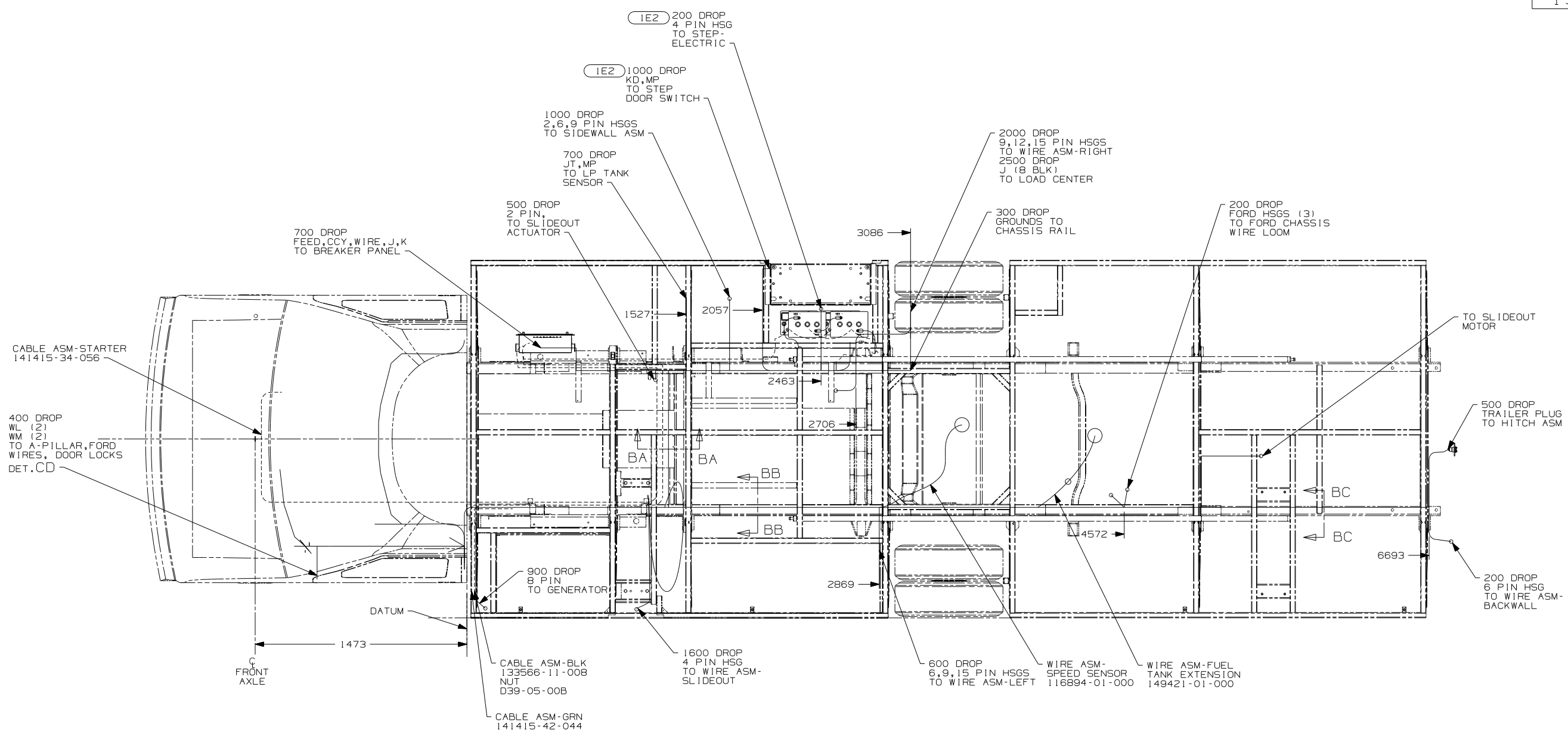

SECTION BA-BA

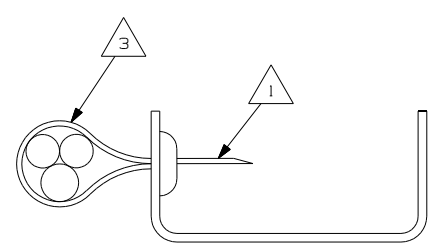

SECTION BB-BB

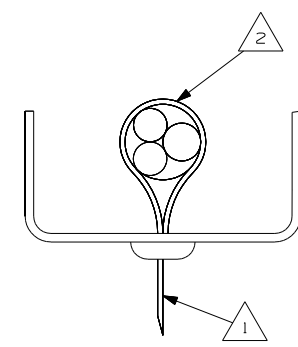

SECTION BC-BC

- NOTES:
- 4 WIRES TO BE TIED TO CROSS MEMBER USING EXISTING HOLES.
  - 3 WIRES TO BE TIED TO TOP OF RAIL USING EXISTING HOLES.
  - 2 WIRES TO BE TIED TO INSIDE OF RAIL USING EXISTING HOLES.
  - 1 CUT OFF EXCESS END OF WIRE TIE.

- 265 CODES/STANDARDS-CSA/CMVSS
- 16E FORD CHASSIS 14,050 LB.6VWR
- 1E2 ENTRANCE STEP-ELEC.
- 1B1 CODES/STANDARDS USA

FIRST USED		06 329B	
DO NOT SCALE DRAWING			
TITLE: WIRING INSTL-CHASSIS			
SHEET 2	PART NO	152745	REV

- 22W BATTERY 63739-01-000 (2)
- TIE DOWN 65451-05-000 (2)
- BOLT 51387-06-000 (4)
- NUT D39-05-00B (4)
- CLIP 44364-02-000 (4)
- BOOT 77479-01-000
- 77479-02-000

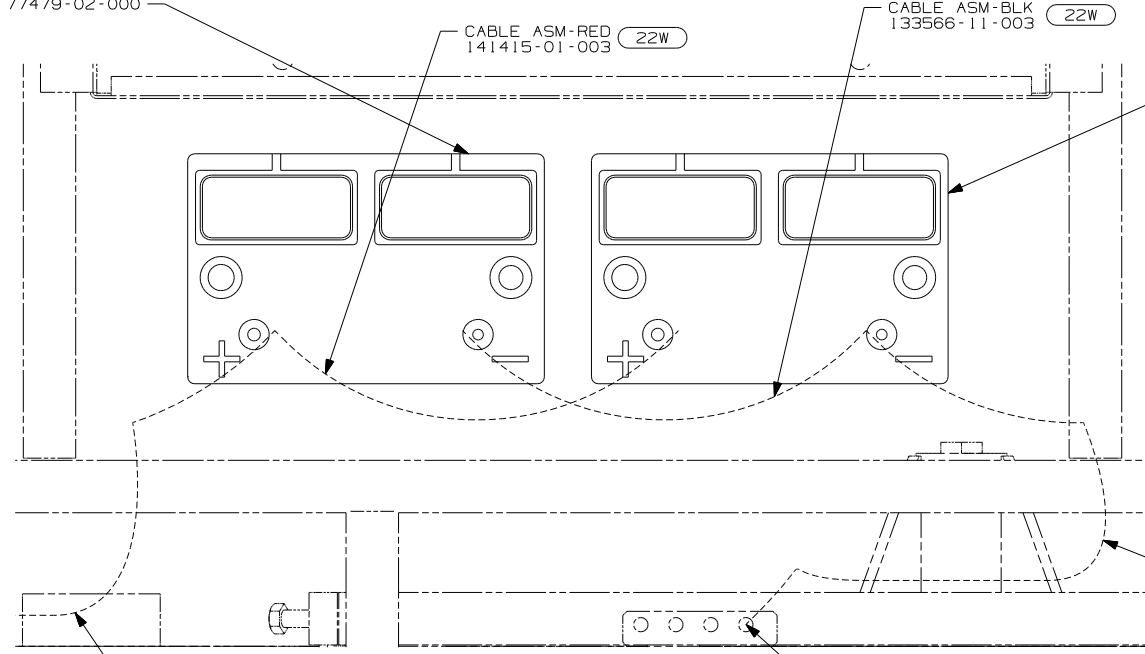

- BATTERY 63739-01-000 (12X)
- TIE DOWN 65451-05-000
- BOLT 51387-06-000 (2)
- NUT D39-05-00B (2)
- CLIP 44364-02-000 (2)
- BOOT 77479-02-000

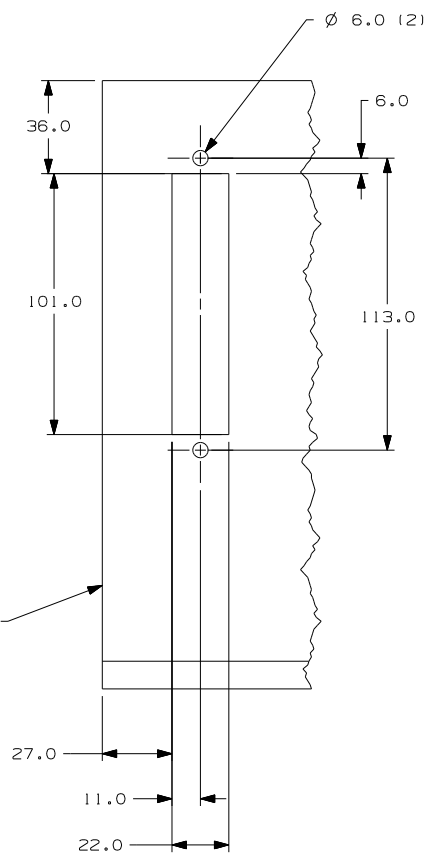

LOWER LEFT DASH PANEL

DETAIL CB 16E

- SWITCH-RADIO POWER 108357-08-000
- ACTUATOR-SWITCH 108356-02-CHT

- PLATE-SWITCH 144363-12-CHT
- NUT 112722-01-CHT (2)

- SWITCH-AUX START 108357-09-000
- ACTUATOR-SWITCH 108356-02-CHT

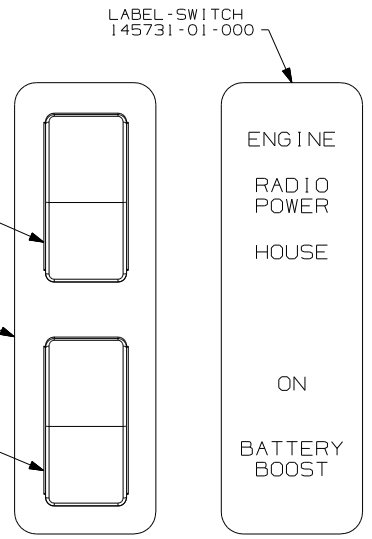

DETAIL CC 16E

- CABLE ASM-YEL 141415-52-021 TO SOLENOID

DETAIL CA 2 IPY 16E

- GROUND BAR BOLT C26-05-00B (2)
- NUT D39-05-00B (2)

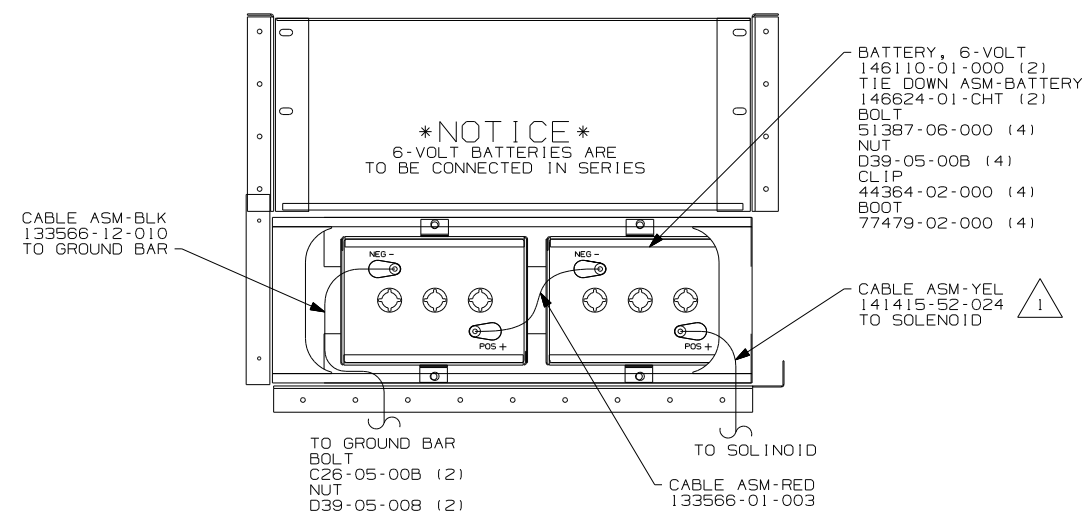

DETAIL CA 644 IPY 16E

REMOVE A-PILLAR LOWER COVER TO ACCESS FORD CONNECTORS TO DOOR ASM. CONNECT RED/ORG TO WL (2 PLACES) CONNECT PK/BLK TO WM (2 PLACES) FOR POWER DOOR LOCK ACTUATOR

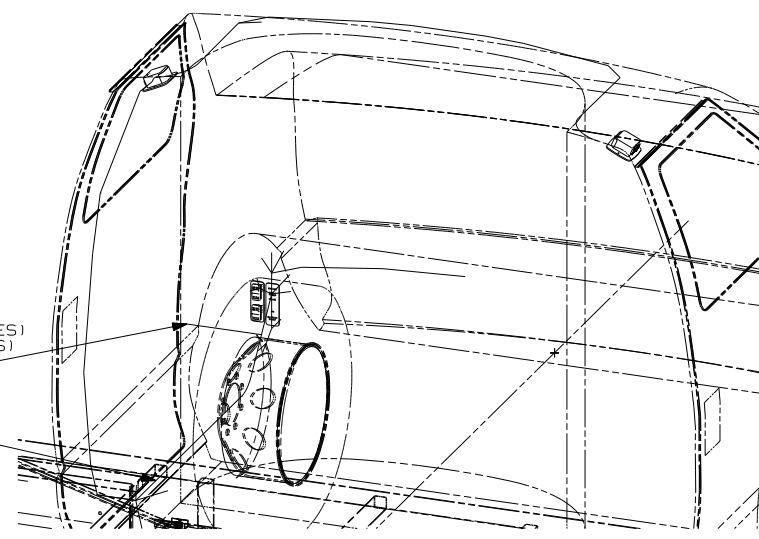

WIRE ASM-CHASSIS (REF)

DETAIL CD 16E

- 644 GREAT ALASKAN RENTAL PACKAGE
- 265 CODES/STANDARDS-CSA/CMVSS
- 22W BATTERY-SECOND
- 16E FORD CHASSIS 14,050 LB.GVWR
- 12X BATTERY-ONE
- 1PY CHEVY CHASSIS 14,050 LB GVWR
- 1B1 CODES/STANDARDS USA

- 2 WITHOUT 644
- 1 LEAD IS MARKED WITH YELLOW TAPE.

NOTES:

FOR ELECTRICAL TORQUE SPECIFICATIONS SEE DWG NO. 128783-01-000

FOR ELECTRICAL CALLOUTS SEE DWG NO. 121339-01-000

FIRST USED	06 329B
TITLE	DO NOT SCALE DRAWING
	WIRING INSTL-CHASSIS
SHEET 3	PART NO 152745 REV
	1 6/15/2006

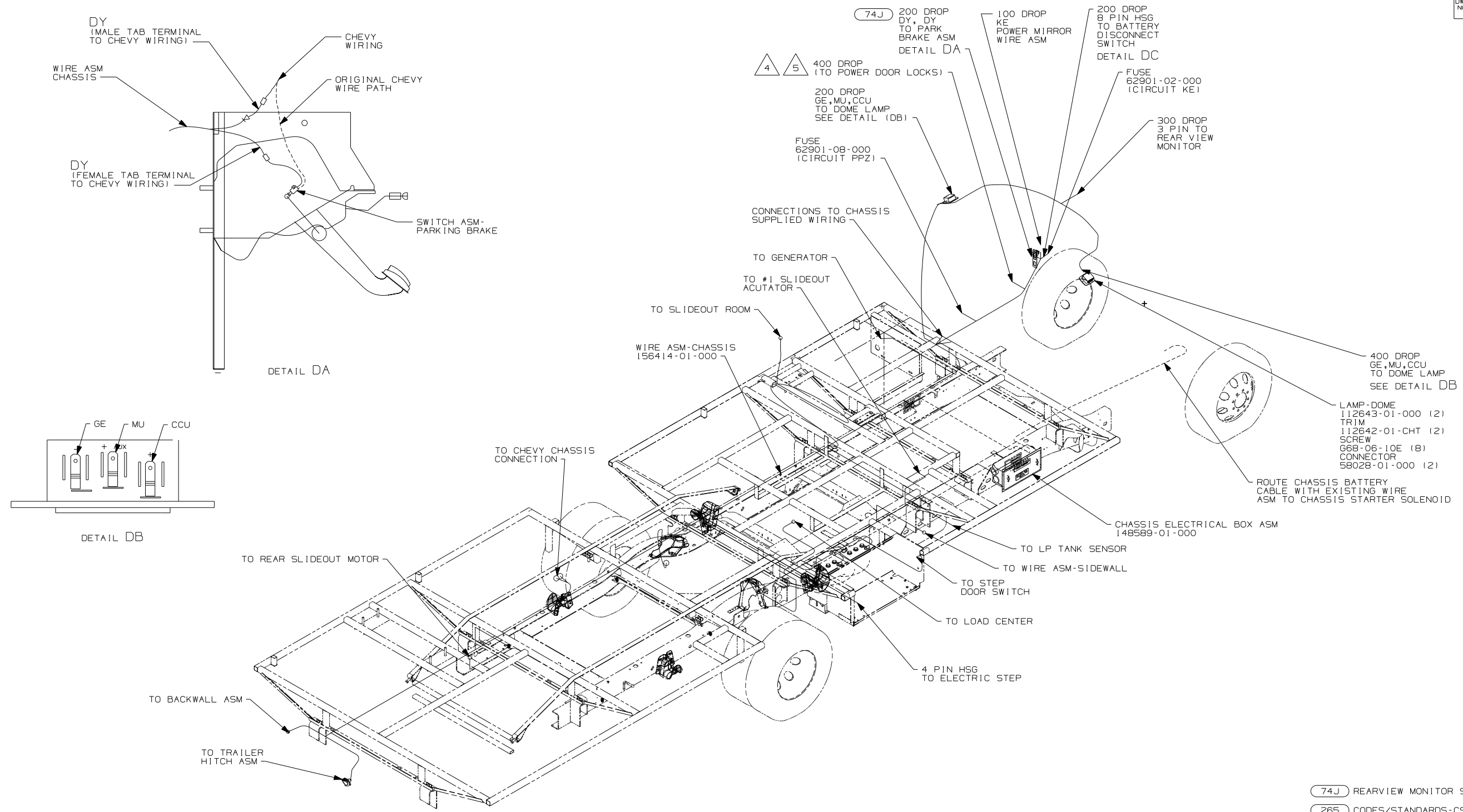

- 5 REMOVE A-PILLAR LOWER COVER TO ACCESS CHEVY CONNECTORS TO DOOR ASM. CONNECT GRAY TO WL (2PLACES) AND CONNECT TAN TO WM (2 PLACES) FOR DOOR LOCK ACTUATOR.
- 4 THE TAN WIRE IS LOCATED IN POSITION A-4 AND THE GRAY WIRE IS IN LOCATION D-5 OF THE 40 PIN CONNECTOR.
- 3 SECURE WIRE ASM AND CABLES WITH WIRE TIE 8343-04-000 OR 116673-01-000 AT NO MOR THAN 600mm BETWEEN TIES ALONG THE ENTIRE ROUTED PATH.
- 2. SECURE CONDUIT 41953, TAB AS REQUIRED, OVER ALL WIRES IN CONTACT WITH SHARP EDGES.
- 1. LEGEND: — WINNEBAGO: - - - - - CABLE: - - - - - CHASSIS SUPPLIED WIRING.

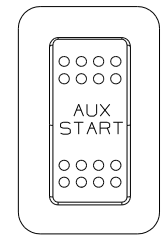

- 74J REARVIEW MONITOR SYS W/AUDIO
- 265 CODES/STANDARDS-CSA/CMVSS
- 28X MIRRORS-EXTERIOR W/DEFROST
- 1PY CHEVY CHASSIS 14,050 LB GVWR
- 1E2 ENTRANCE STEP-ELEC.
- 1B1 CODES/STANDARDS USA

FIRST USED	06 329B	
TITLE:	DO NOT SCALE DRAWING	
	WIRING INSTL-CHASSIS	
SHEET 4	PART NO	152745 REV

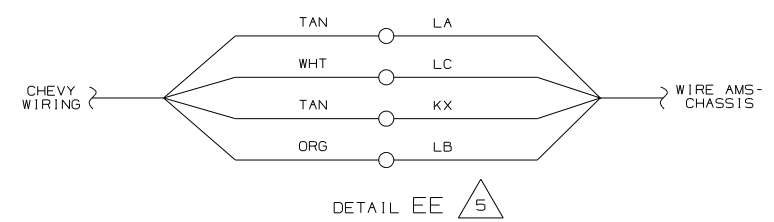
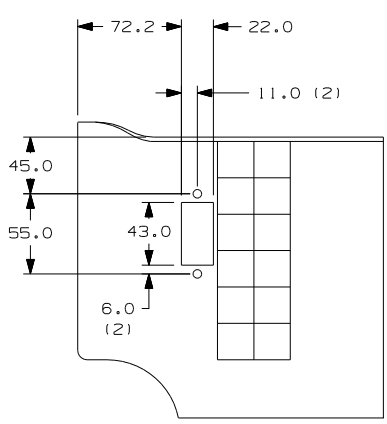

CABLE ASM-STARTER  
141415-34-029  
(TO STARTER SOLENOID)

VIEW ED-ED

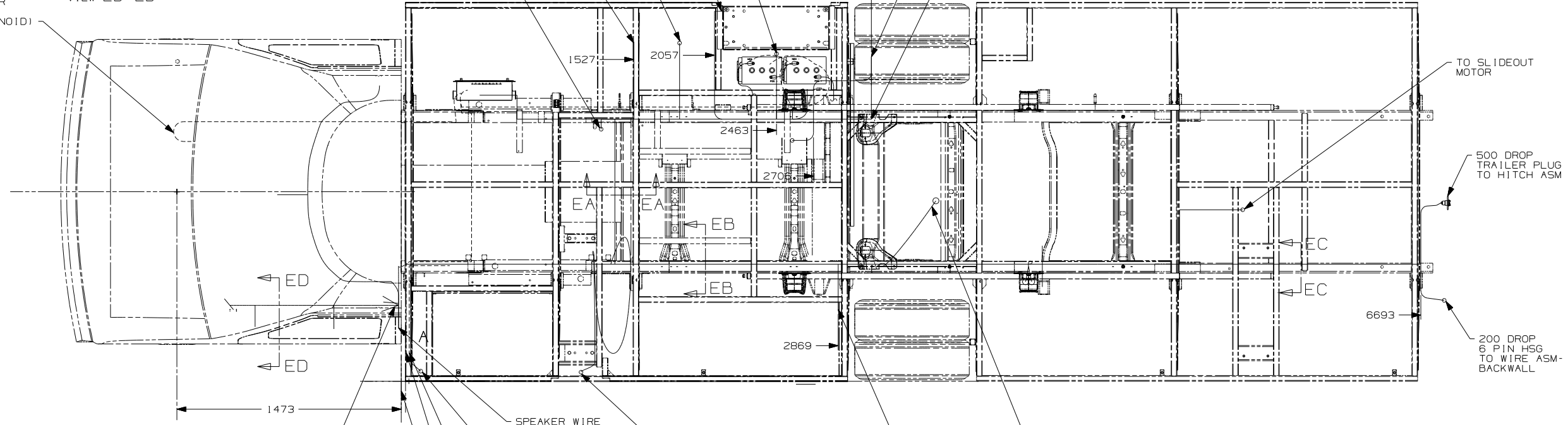

6 RUN ONLY  
CIRCUIT  
CONNECTION

- NOTES:
- 6 CONNECT "FEED" CIRCUIT TO CHEVY BROWN WIRE AT B-POST.
  - 5 BOTH POSITIVE WIRES ARE TAN. TO TEST, TURN THE RADIO FADE ALL THE WAY TO THE LEFT. CONNECT THE NEGATIVE TERMINAL OF A TEST SPEAKER TO THE WHITE WIRE. THEN ALTERNATE THE TWO TAN WIRES TO THE POSITIVE TERMINAL. WHICHEVER IS THE LOUDER IS THE ONE THAT CONNECTS TO CIRCUIT LA. THE OTHER TAN WIRE CONNECTS TO CIRCUIT KX.
  - 4 WIRES TO BE TIED TO CROSS MEMBER USING EXISTING HOLES.
  - 3 WIRES TO BE TIED TO TOP OF RAIL USING EXISTING HOLES.
  - 2 WIRES TO BE TIED TO INSIDE OF RAIL USING EXISTING HOLES.
  - 1 CUT OFF EXCESS END OF WIRE TIE.

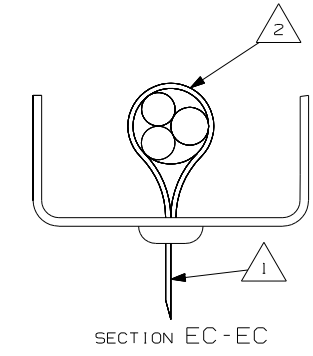
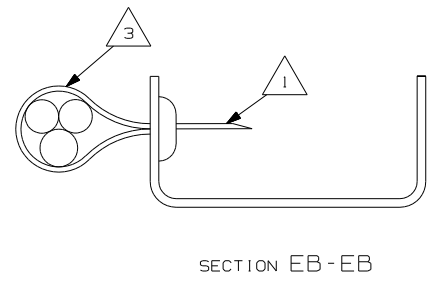
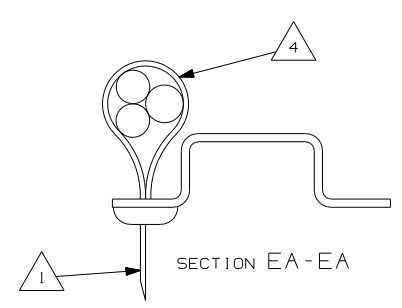

- 265 CODES/STANDARDS-CSA/CMVSS
- IPY CHEVY CHASSIS 14,050 LB GVWR
- IE2 ENTRANCE STEP-ELEC.
- IB1 CODES/STANDARDS USA

FIRST USED	06 329B
TITLE	DO NOT SCALE DRAWING
WIRING INSTL-CHASSIS	
SHEET 5	PART NO 152745 REV