



DANGER

Danger of electrical shock, burns or death. Always remove all power sources before attempting any repair, service or diagnostic work. Power can be present from shore power, generator, inverter or battery. All power sources must be disabled and secured before performing any service.



CAUTION

If you lack the skills, tools or equipment to perform diagnostic or repair work leave such work to an authorized Winnebago Industries dealer or other qualified shop.

DRAWING NO.	FEATURE	SHEETS
155758-01	16E	1,2,3
155758-02	1PY	3,4,5

RELEASE	REV/DATE	OWG NO
	A	155758
REV ZONE	REVISION RECORD	DATE
		DFTR-016

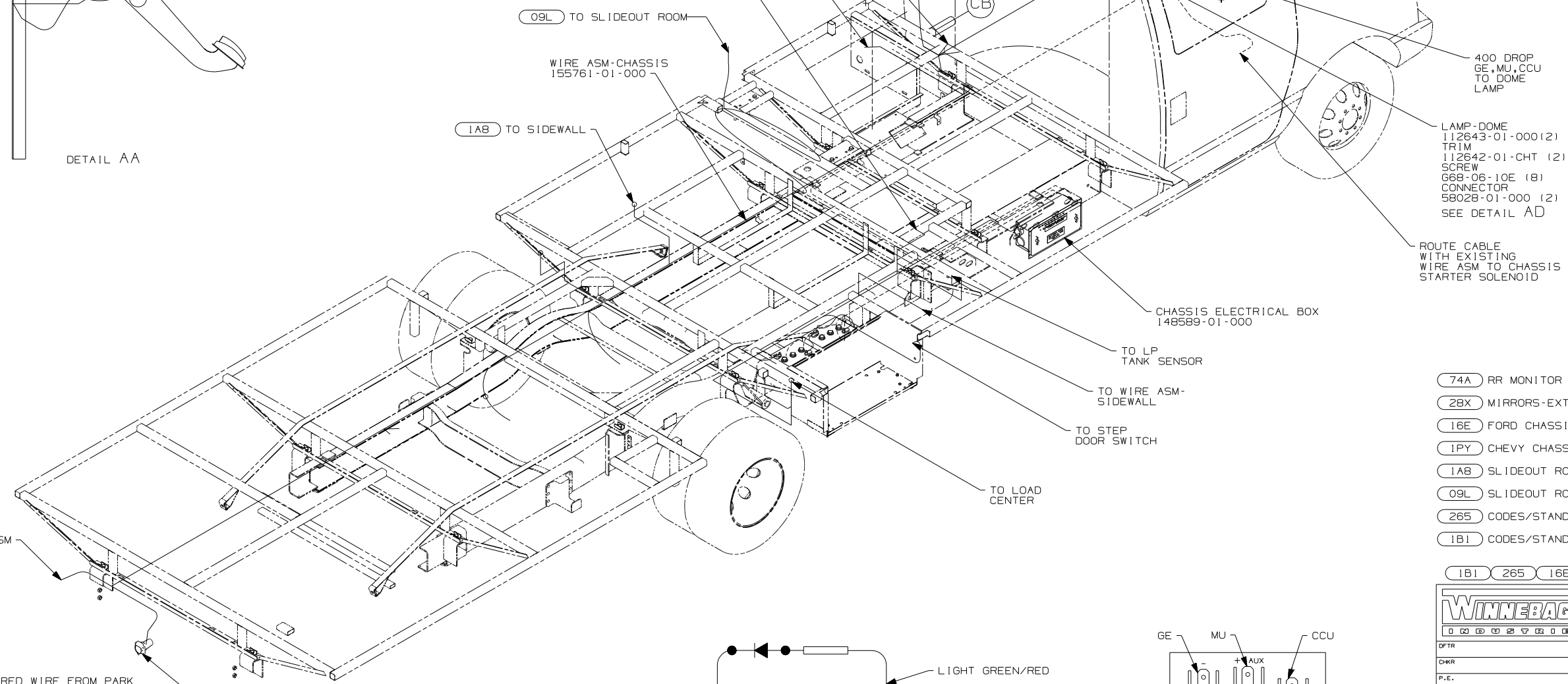
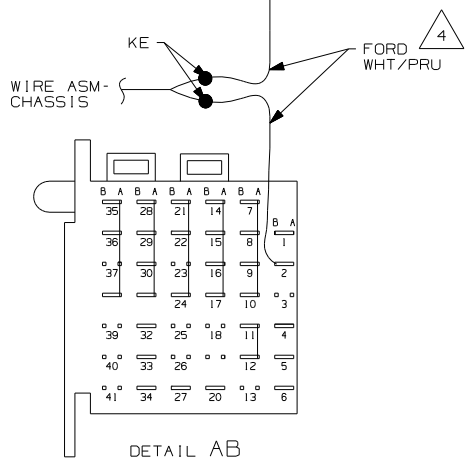
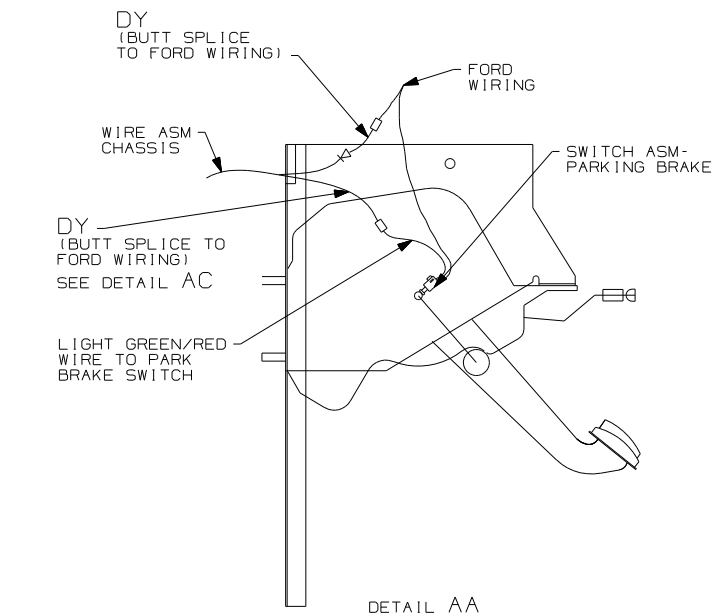

5. CUT LIGHT GREEN/RED WIRE FROM PARK BRAKE SWITCH AND RECONNECT TO CIRCUIT DY OF CHASSIS ASM AS SHOWN.
4. CUT WIRE AND RECONNECT AS SHOWN.
3. SECURE WIRE ASM AND CABLES WITH WIRE TIE 8343-04-000 OR 116673-01-000 AT NOT MORE THAN 600 MM CENTER ALONG ENTIRE ROUTED PATH.
2. SECURE CONDUIT 41953-09, -10, -11, -13, AND -14 OVER ALL WIRES IN CONTACT WITH SHARP EDGES.
1. LEGEND: — WINNEBAGO: - - - - - CABLE: - - - - - CHASSIS SUPPLIED WIRING.

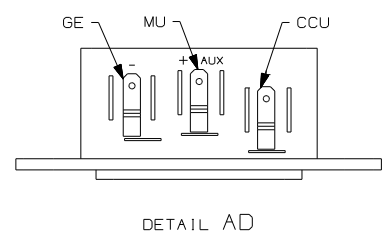
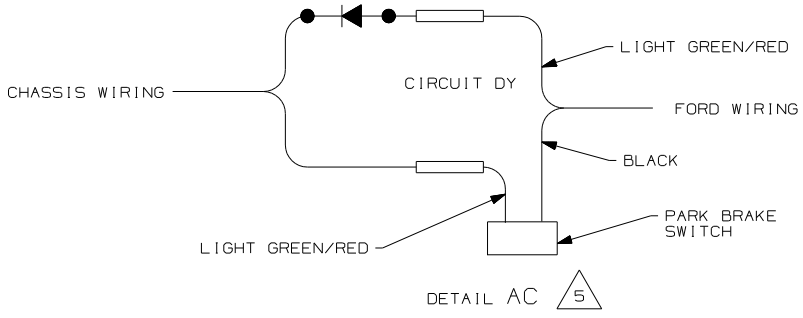

WINNEBAGO COPYRIGHT 2006 WINNEBAGO INDUSTRIES, INC.

DFTR	ORIG. DATE
CHKR	ALL DIMENSIONS ARE IN MILLIMETERS
P.E.	
M.E.	FIRST USED
DSNR	06 329K

UNSPECIFIED TOLERANCES ARE: MATERIAL:

WHOLE DIM (X)	: 3
ONE-PLACE (X.X)	: 1.5
TWO-PLACE (X.XX)	: 0.50
ANGLE	: 1°

THIRD ANGLE PROJECTION

DO NOT SCALE DRAWING

TITLE: **WIRING INSTL-CHASSIS**

SHEET 1 of 5 PART NO 155758 REV

REF: 1 6/15/2006

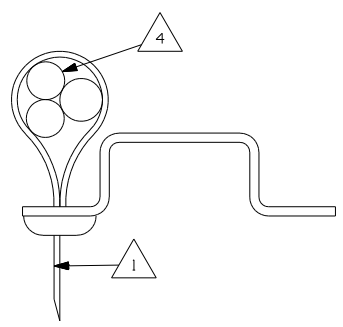
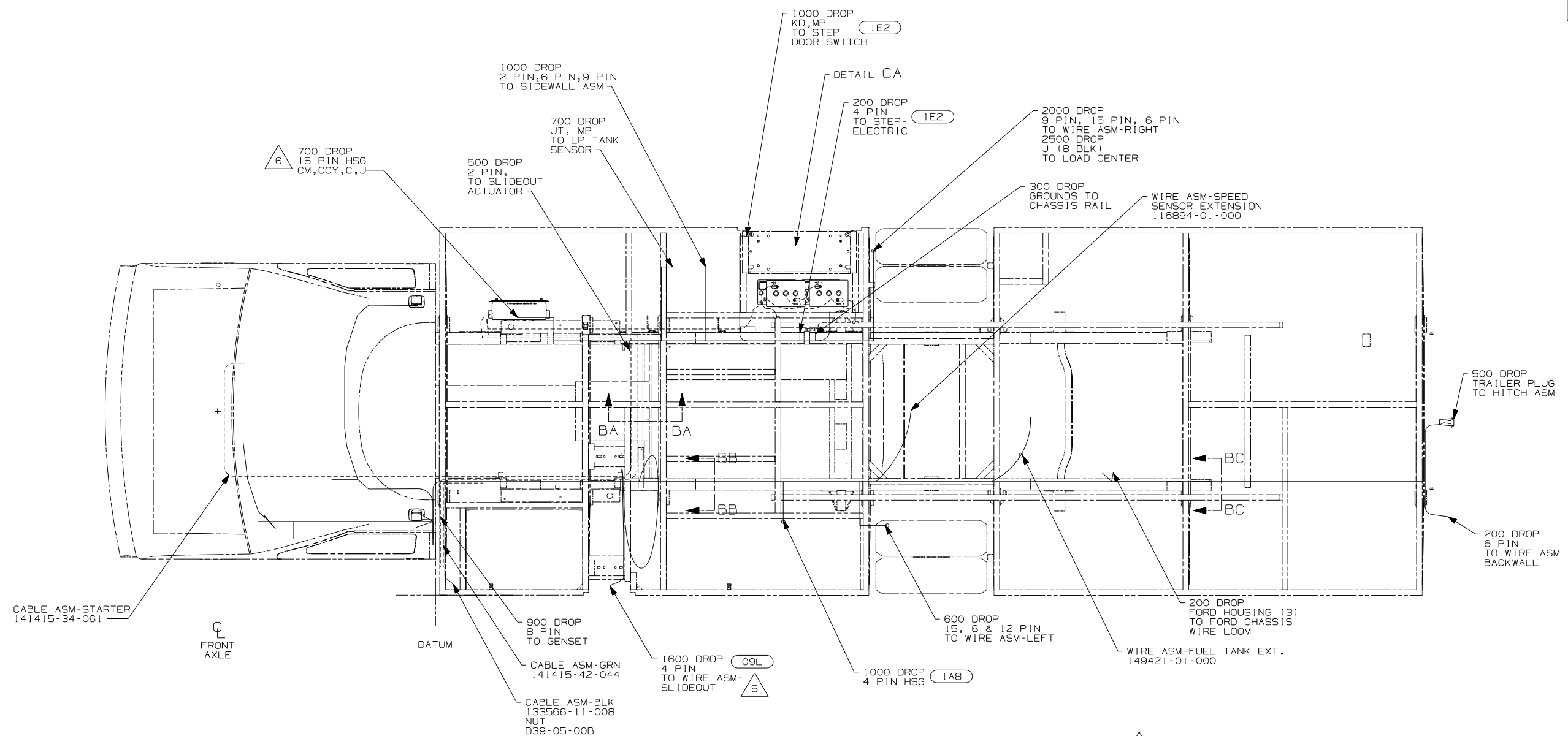

SECTION BA-BA

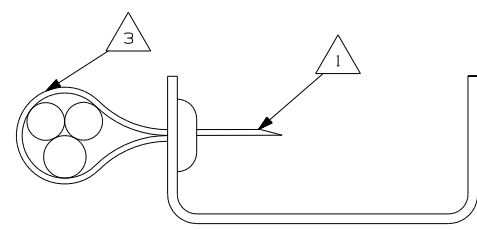

SECTION BB-BB

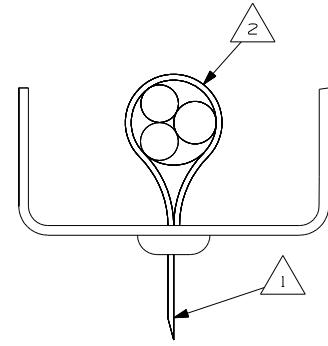

SECTION BC-BC

- 6 SEE CHASSIS ELECTRICAL BOX ASM FOR ADDITIONAL INFORMATION.
- 5 THIS DROP MOVES TO LOCATION 2350 FOR (IAB).
- 4 WIRES TO BE TIED TO CROSS MEMBER USING EXISTING HOLES.
- 3 WIRES TO BE TIED TO TOP OF RAIL USING EXISTING HOLES.
- 2 WIRES TO BE TIED TO INSIDE OF RAIL USING EXISTING HOLES.
- 1 CUT OFF EXCESS END OF WIRE TIE.

NOTES:

- (O9L) SLIDEOUT ROOM FRONT LEFT
- (IAB) SLIDEOUT ROOM FRONT LEFT WO
- (16E) FORD CHASSIS 14,050 LB.GVWR
- (IE2) ENTRANCE STEP-ELEC.
- (265) ENTRANCE STEP-ELECTRIC
- (1B1) CODES/STANDARDS USA

FIRST USED	06 329K	
TITLE:	DO NOT SCALE DRAWING	
	WIRING INSTL-CHASSIS	
SHEET 2	PART NO	155758
	REV	

- 22W BATTERY
63739-01-000 (2)
TIEDOWN
65451-05-000 (2)
BOLT
51387-06-000 (4)
NUT
D39-05-00B (4)
CLIP
44364-02-000 (4)
BOOT
77479-01-000
77479-02-000

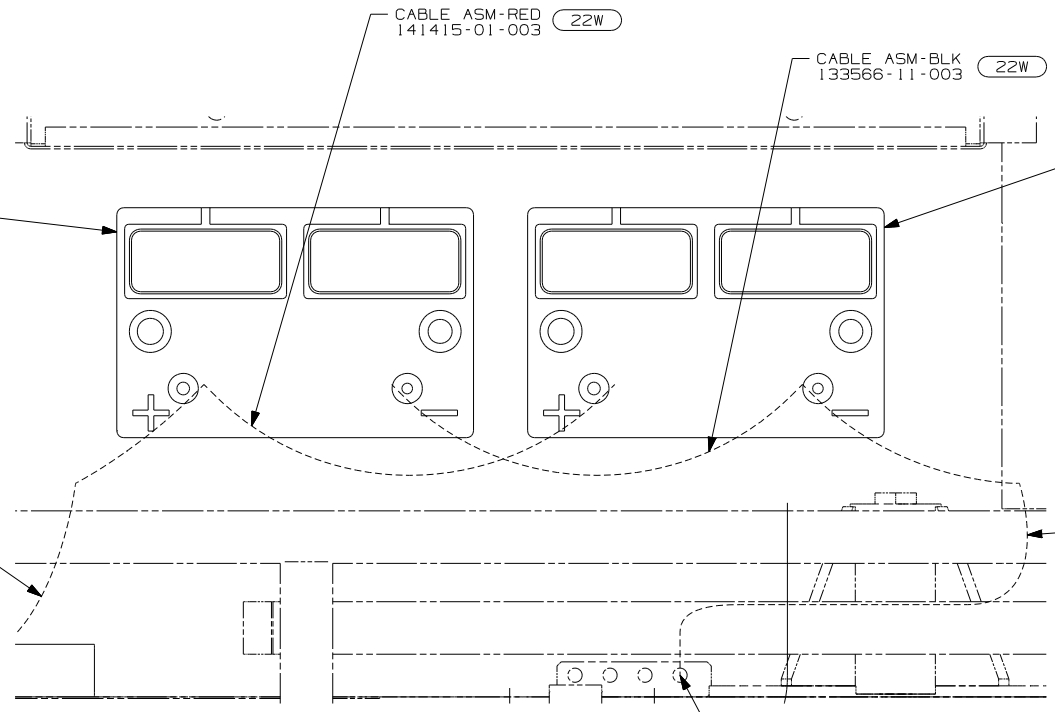

DETAIL CA 2
1PY 16E

NOTICE
6-VOLT BATTERIES ARE
TO BE CONNECTED IN SERIES

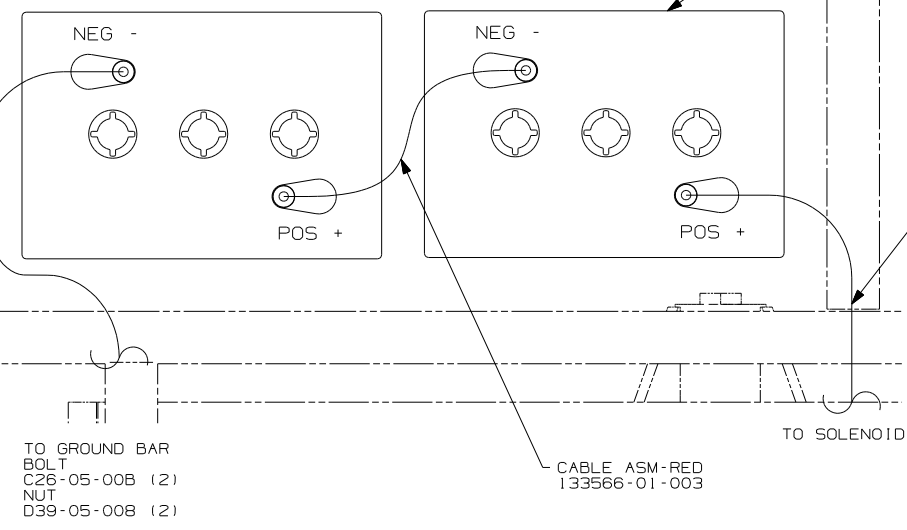

DETAIL CA 644 16E 1PY

- 12X BATTERY
63739-01-000
TIEDOWN
65451-05-000
BOLT
51387-06-000
NUT
D39-05-00B (2)
CLIP
44364-02-000 (2)
BOOT
77479-02-000

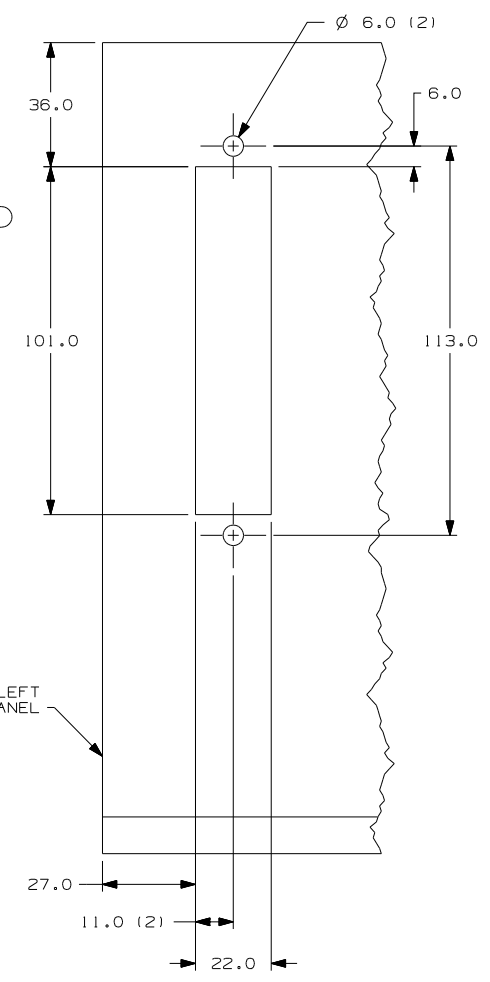

VIEW CB 16E

REMOVE A-PILLAR LOWER COVER
TO ACCESS FORD CONNECTORS TO DOOR ASM.
CONNECT RED/ORG TO WL (2 PLACES)
CONNECT PK/BLK TO WM (2 PLACES)
FOR DOOR LOCK ACTUATOR.

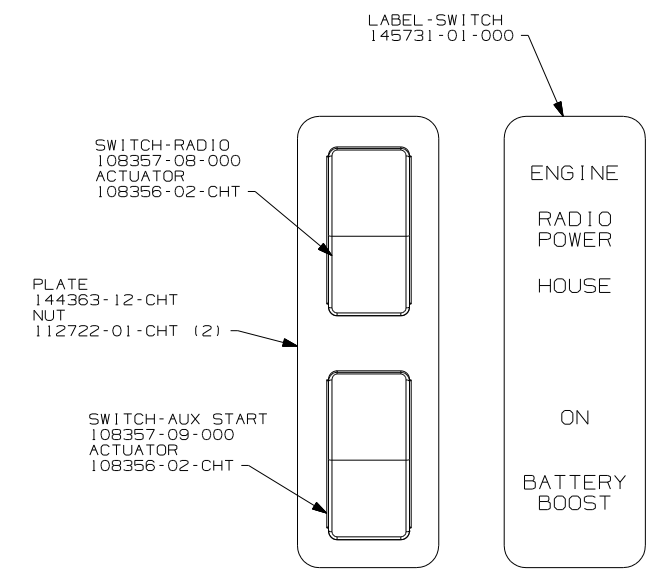

DETAIL CC 16E

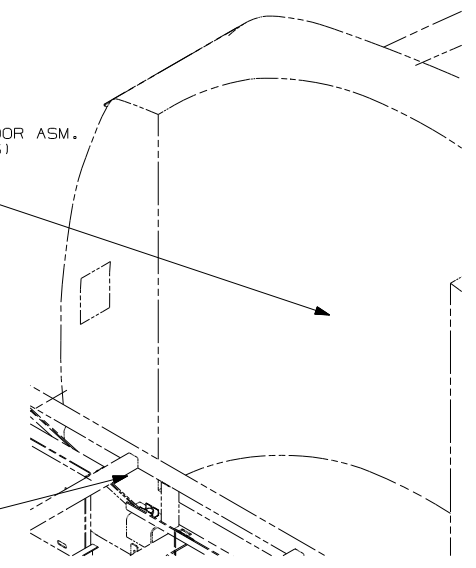

DETAIL CD 16E

- NOTES:
- 2 WITHOUT 644.
 - 1 LEAD IS MARKED WITH YELLOW TAPE.

- 644 GREAT ALASKAN RENTAL PACKAGE
- 22W BATTERY-SECOND
- 12X BATTERY-ONE
- 265 CODES/STANDARDS-CSA/CMVSS
- 16E FORD CHASSIS 14,050 GVWR
- 1B1 CODES/STANDARDS USA

1B1 265	
FIRST USED 06 329K	
TITLE: DO NOT SCALE DRAWING	
WIRING INSTL-CHASSIS	
SHEET 3	PART NO 155758 REV

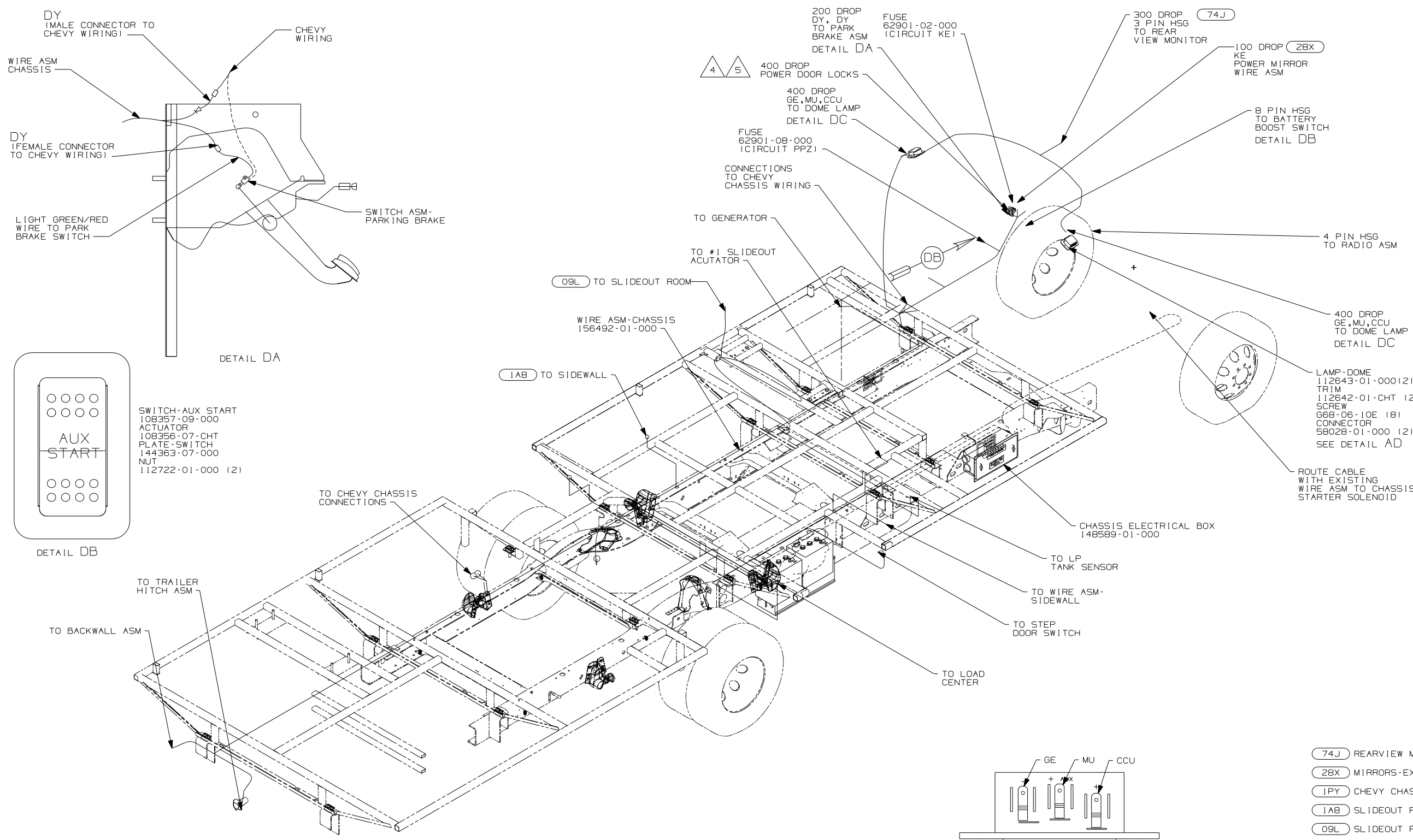

- 4 THT TAN WIRE IS LOCATED IN POSITION A-4 AND THE GRAY WIRE IS IN THE LOCATION D-5 OF THE CHEVY 40 PIN CONNECTOR.
3. SECURE WIRE ASM AND CABLES WITH WIRE TIE 8343-04-000 OR 116673-01-000 AT NOT MORE THAN 600 MM CENTER ALONG ENTIRE ROUTED PATH.
2. SECURE CONDUIT 41953-09, -10, -11, -13, AND -14 OVER ALL WIRES IN CONTACT WITH SHARP EDGES.
1. LEGEND: — WINNEBAGO: - - - - - CABLE: CHASSIS SUPPLIED WIRING.

5 REMOVE A-PILLAR LOWER COVER TO ACCESS CHEVY CONNECTORS TO DOOR ASM. CONNECT GRY TO WL (2 PLACES) AND CONNECT TAN TO WM (2 PLACES) FOR DOOR LOCK ACTUATOR.

74J	REARVIEW MONITOR SYS W/AUDIO
28X	MIRRORS-EXTERIOR W/DEFROST
1PY	CHEVY CHASSIS 14,050 LB GVWR
1AB	SLIDEOUT ROOM FRONT LEFT WO
09L	SLIDEOUT ROOM FRONT LEFT
265	CODES/STANDARDS-CSA/CMVSS
1B1	CODES/STANDARDS USA

FIRST USED	06 329K
TITLE:	DO NOT SCALE DRAWING
	WIRING INSTL-CHASSIS
SHEET 4	PART NO 155758 REV

