



**DANGER**

**Danger of electrical shock, burns or death.** Always remove all power sources before attempting any repair, service or diagnostic work. Power can be present from shore power, generator, inverter or battery. All power sources must be disabled and secured before performing any service.



**CAUTION**

If you lack the skills, tools or equipment to perform diagnostic or repair work leave such work to an authorized Winnebago Industries dealer or other qualified shop.

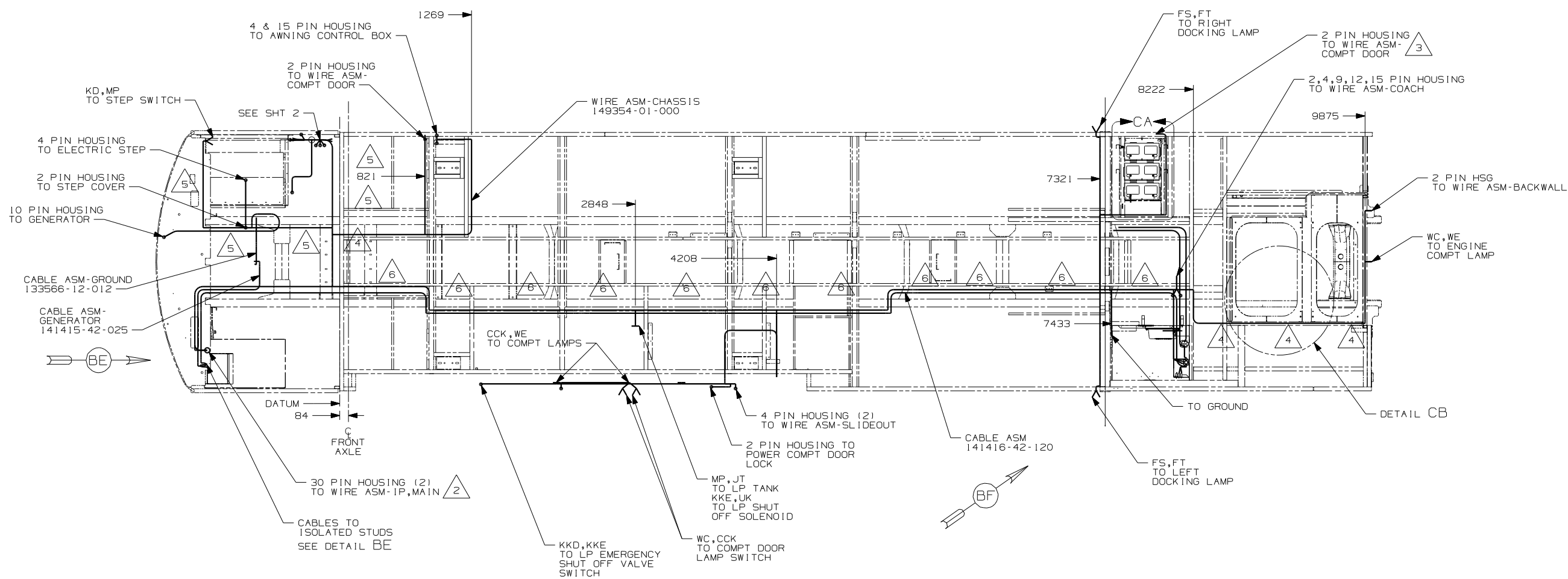

(1FC) FREIGHTLINER CHASSIS-24,850#  
 (265) CODES/STANDARDS-CSA/CMVSS  
 (1B1) CODES/STANDARDS-USA  
 (1FC) (1B1) (265)

**WINNEBAGO** COPYRIGHT 2004 WINNEBAGO INDUSTRIES, INC.  
 DFR: \_\_\_\_\_ ORIG. DATE \_\_\_\_\_  
 CHKR: \_\_\_\_\_ ALL DIMENSIONS ARE IN MILLIMETERS  
 P.E.: \_\_\_\_\_  
 M.E.: \_\_\_\_\_ FIRST USED \_\_\_\_\_  
 DSNR: \_\_\_\_\_ **05 S40AD**  
 UNSPECIFIED TOLERANCES ARE: MATERIAL:  
 HOLE DIM (X) :  
 ONE-PLACE (X.X) :  
 TWO-PLACE (X.XX) :  
 ANGLE :  
 THIRD ANGLE PROJECTION   
**DO NOT SCALE DRAWING**  
 TITLE: **WIRING INSTL-CHASSIS**  
 SHEET 1 OF 3 PART NO **149347**

- 6 CLAMP 83610-01-000, SCREW G39-08-12B
- 5 CLAMP 10497-03-000, SCREW G39-08-12B
- 4 USE TIE-WIRE 8343-04-000 TO SECURE WIRES TO FLOOR SUPPORT FRAME AT LEAST ONCE EVERY 600MM.
- 3 ROUTE AND CLAMP WIRE ALONG UPPER TUBE IN BATTERY COMPT.
- 2 SEE WIRING INSTL-FRONT END FOR ADDITIONAL INFORMATION.

1. LEGEND: ——— WINNEBAGO: - - - - - CABLE: - - - - - CHASSIS SUPPLIED WIRING.  
 NOTES:

FOR ELECTRICAL TORQUE SPECIFICATIONS SEE DWG NO. 128783-01-000

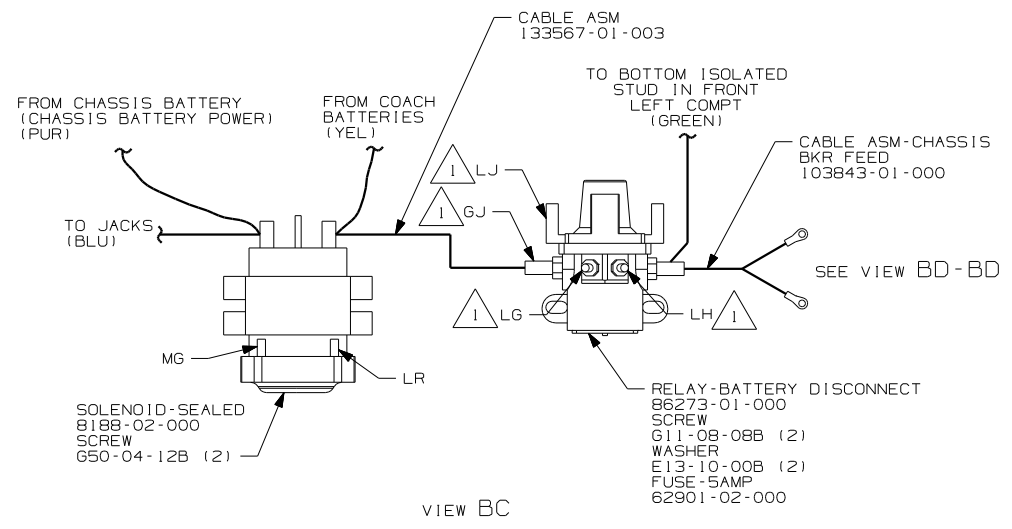
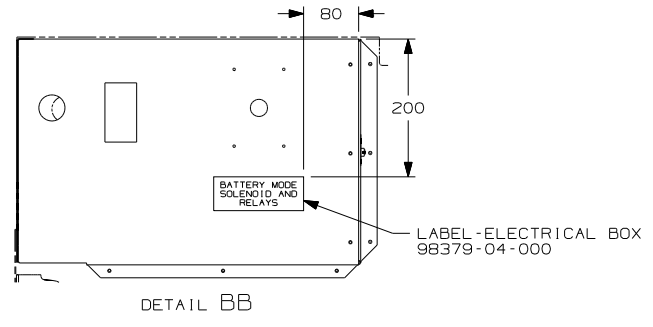
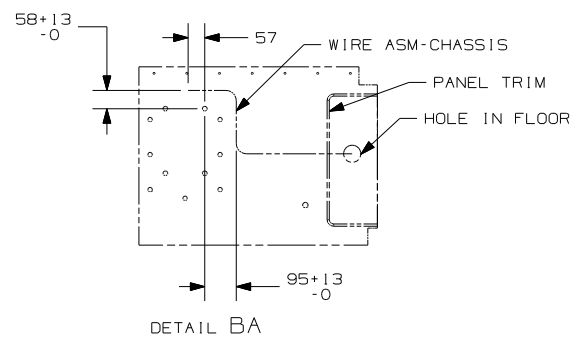

- 8 PIN HOUSING (11)
- TO AWNING SELECTOR SWITCH
- TO AWNING CONTROL SWITCH
- TO STEP SWITCH
- TO BATTERY DISCONNECT SWITCH
- TO COMPT DOOR LOCK SWITCH
- TO DOOR LOCK SWITCH
- TO PORCH LAMP SWITCH
- TO LOUNGE CEILING LAMP SWITCH
- TO STEP COVER SWITCH
- TO PASSENGER SUNVISOR SWITCH

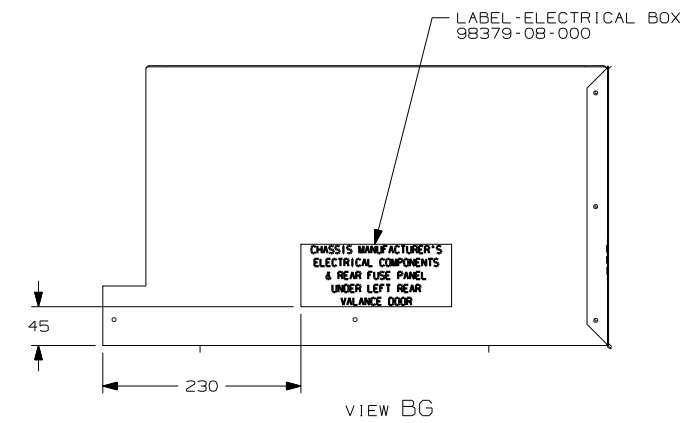
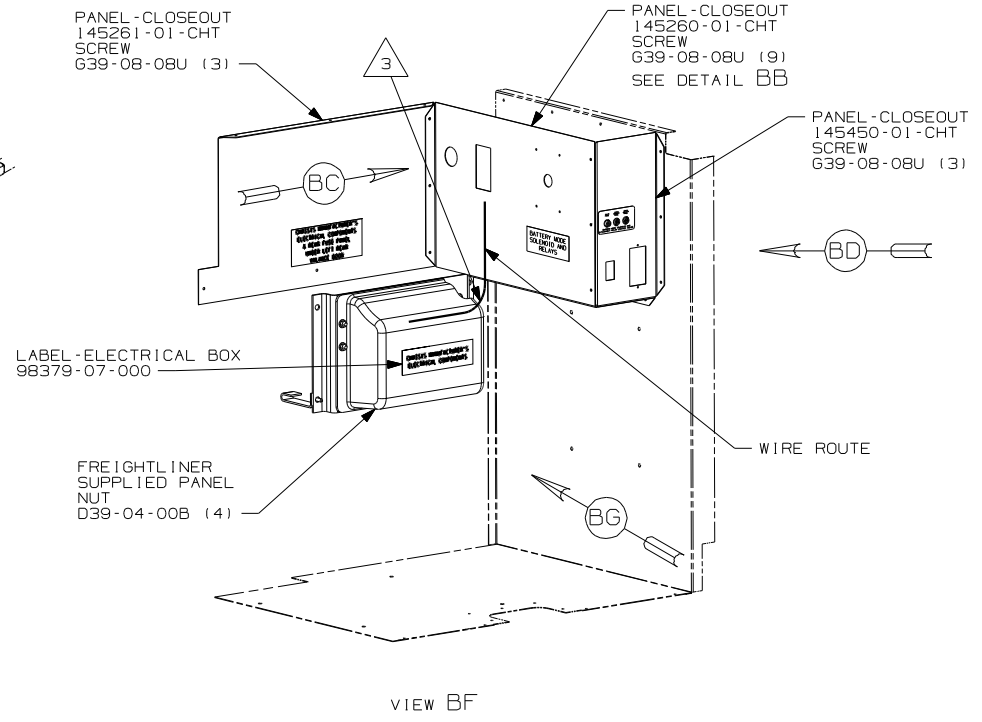
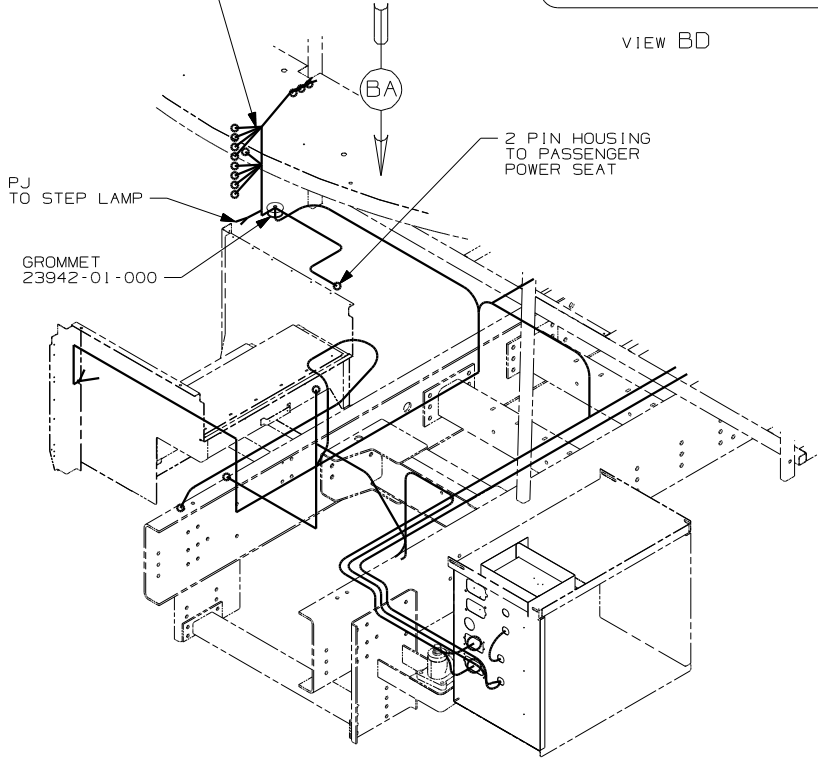
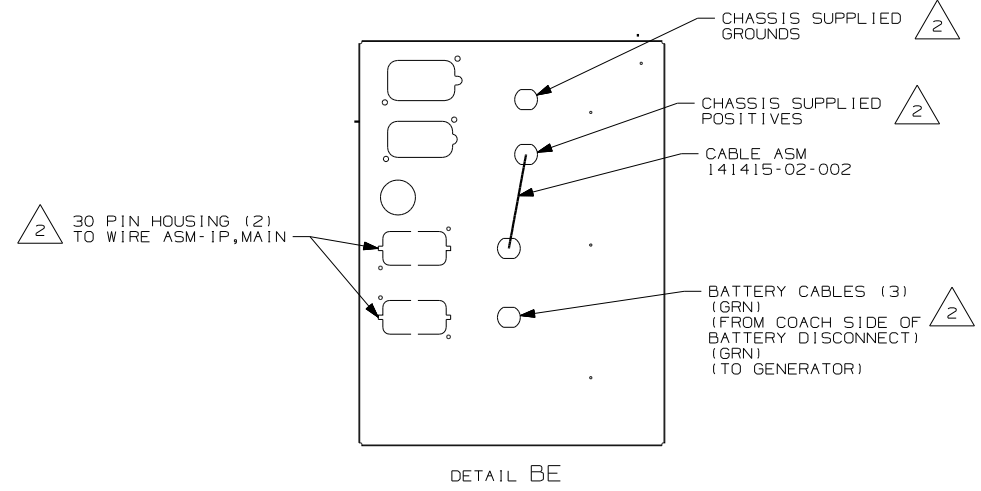
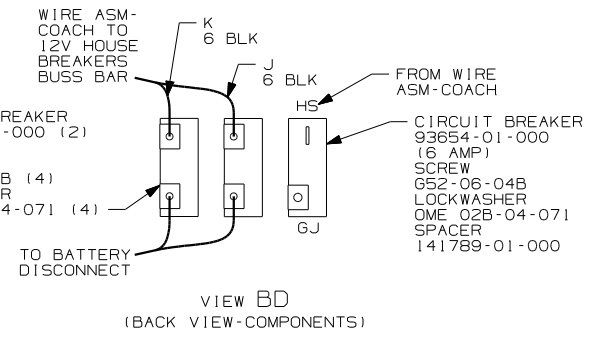
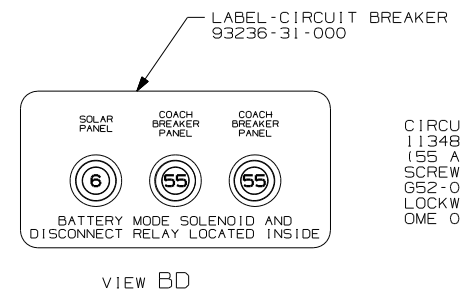

- NOTES:
- 3 BOX TO BE ORIENTED SO CHASSIS WIRING ROUTES OUT THE TOP RIGHT CORNER.
  - 2 SEE WIRING INSTL-FRONT END FOR ADDITIONAL INFORMATION.
  - 1 CIRCUITS BRANCH FROM WIRE ASM-CHASSIS.

FOR ELECTRICAL TORQUE SPECIFICATIONS SEE DWG NO. 128783-01-000

FIRST USED	05 S40AD
DO NOT SCALE DRAWING	
TITLE:	WIRING INSTL-CHASSIS
SHEET 2	PART NO 149347

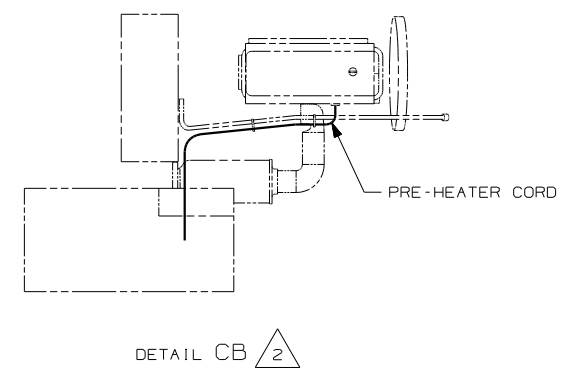
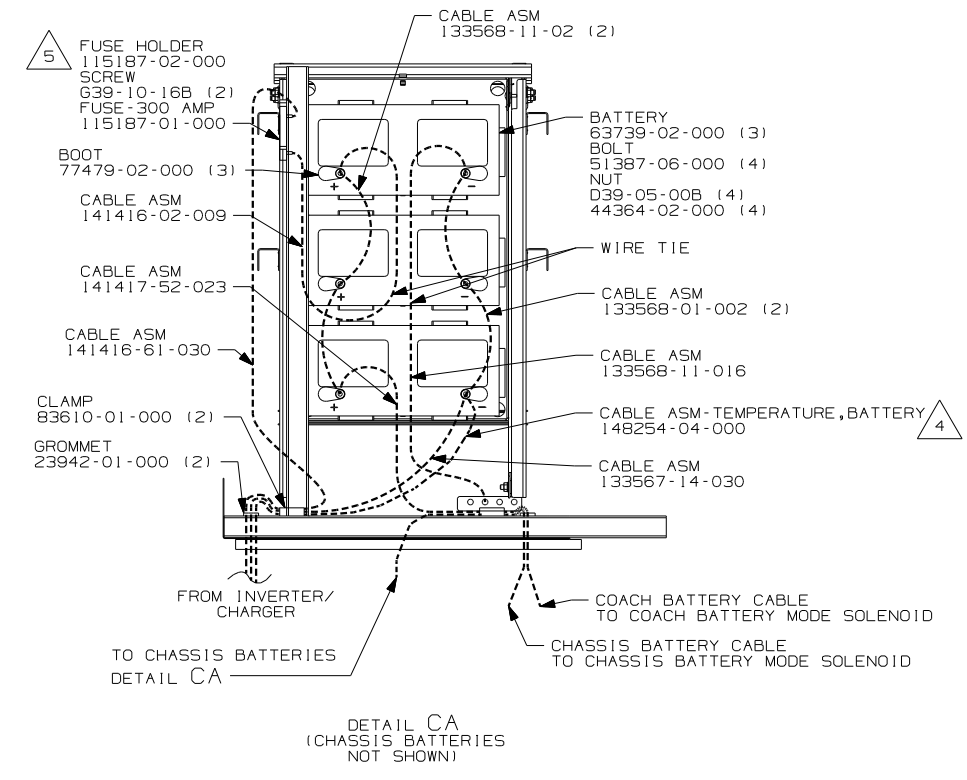
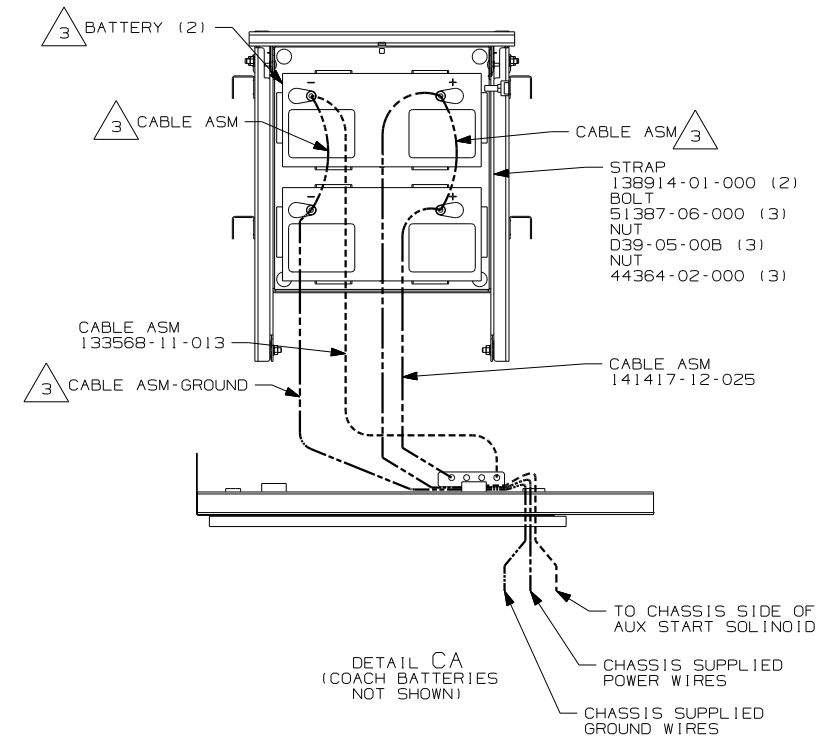

5 MOUNT FUSE HOLDER HORIZONTALLY 20mm DOWN FROM FLOOR TUBE.

4 CONNECT RING TERMINAL OF CABLE ASM-TEMP, BATTERY TO NEGATIVE POST AS SHOWN AND ROUTE CABLE WITH NEGATIVE BATTERY CABLE TO INVERTER.

3 SUPPLIED WITH CHASSIS

2 SECURE CORD AWAY FROM ALL MOVING PARTS AND EXHAUST WITH TIE-WIRE 93147-01-000 AS REQUIRED.

1. LEGEND: — WINNEBAGO: - - - - - CABLE: - - - - - CHASSIS SUPPLIED WIRING.

FOR ELECTRICAL TORQUE SPECIFICATIONS SEE DWG NO. 128783-01-000

FIRST USED	05 S40AD
TITLE	DO NOT SCALE DRAWING
SHEET 3	WIRING INSTL-CHASSIS
PART NO	149347