



DANGER

Danger of electrical shock, burns or death. Always remove all power sources before attempting any repair, service or diagnostic work. Power can be present from shore power, generator, inverter or battery. All power sources must be disabled and secured before performing any service.



CAUTION

If you lack the skills, tools or equipment to perform diagnostic or repair work leave such work to an authorized Winnebago Industries dealer or other qualified shop.

DRAWING NO.	FEATURE
148962-01	-----
148962-12	(1B1) (78J)
148962-14	(1B1) (78J) (13X)
148962-16	(265) (78J)
148962-18	(265) (78J) (13X)

RELEASE	REV DATE	DWG NO	148962
REV ZONE	REVISION RECORD	DATE	DFTR-016

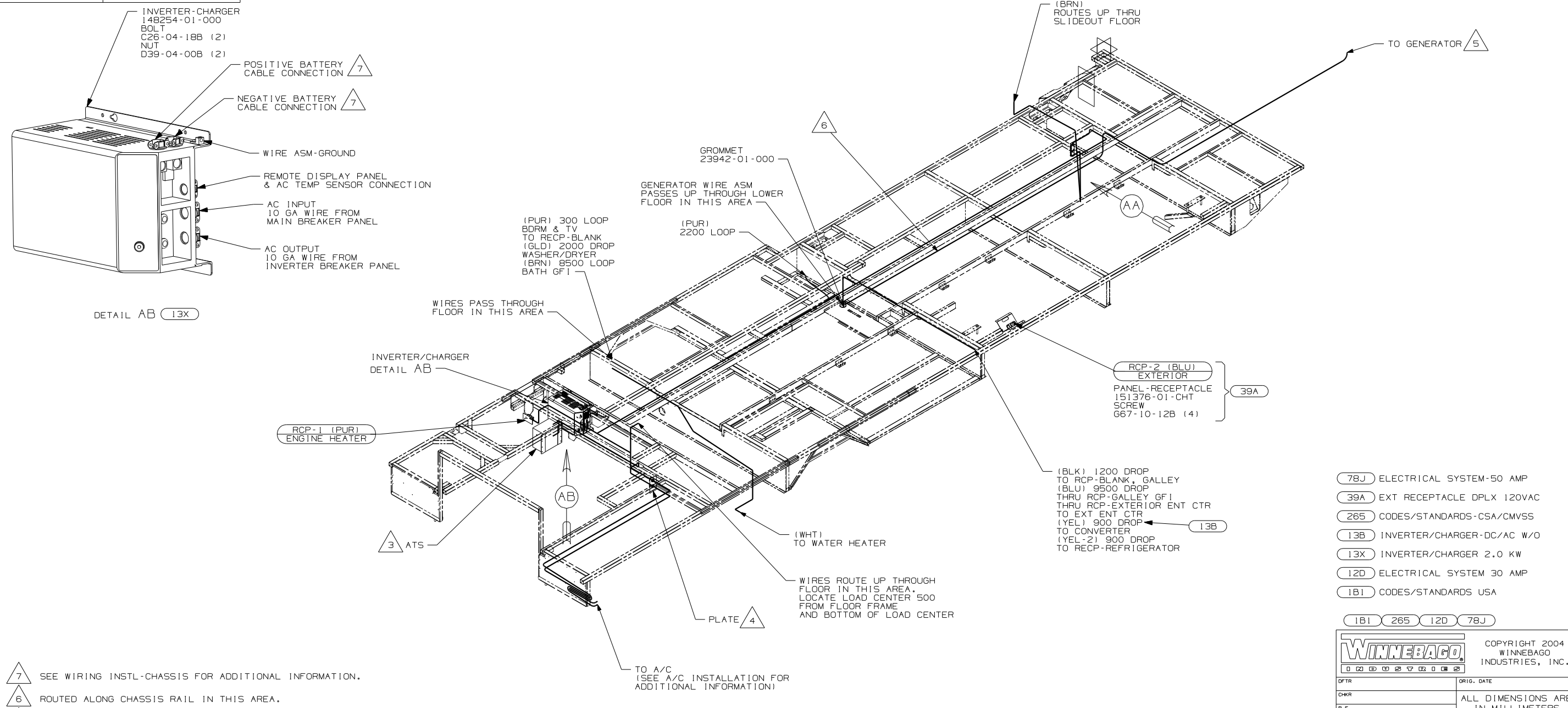

- (7) SEE WIRING INSTL-CHASSIS FOR ADDITIONAL INFORMATION.
 - (6) ROUTED ALONG CHASSIS RAIL IN THIS AREA.
 - (5) SEE GENERATOR INSTALLATION FOR ADDITIONAL INFORMATION.
 - (4) SEE A/C INSTALLATION FOR ADDITIONAL INFORMATION.
 - (3) SEE LOAD CENTER/ATS ASM FOR ADDITIONAL INFORMATION.
2. WIRE THAT REST ON WIRE TRAYS ARE TO BE TIED DOWN WITH WIRE TIE 8343-02-000.
 1. ALL WIRES TO BE SECURED WITH CLAMP 10495 OR 10497 OR WIRE TIE 8343 OR 108046 EVERY 600MM, USE SCREW G67-XX-XXX OR G56-XX-XXX AS APPROPRIATE FOR INTALLATION.

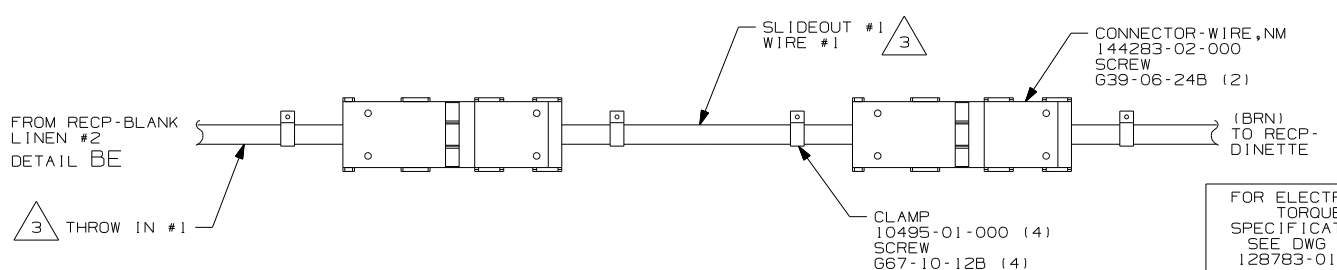

FOR ELECTRICAL TORQUE SPECIFICATIONS SEE DWG NO. 128783-01-000

(X-X) FOR ELECTRICAL CALLOUTS SEE DWG NO. 121339-01-000

- (78J) ELECTRICAL SYSTEM-50 AMP
- (39A) EXT RECEPTACLE DPLX 120VAC
- (265) CODES/STANDARDS-CSA/CMVSS
- (13B) INVERTER/CHARGER-DC/AC W/O
- (13X) INVERTER/CHARGER 2.0 KW
- (12D) ELECTRICAL SYSTEM 30 AMP
- (1B1) CODES/STANDARDS USA

WINNEBAGO INDUSTRIES, INC. COPYRIGHT 2004

DFTR	ORIG. DATE
CHKR	ALL DIMENSIONS ARE IN MILLIMETERS
P.E.	
M.E.	FIRST USED
DSNR	05 P36G

UNSPECIFIED TOLERANCES ARE: MATERIAL:

WHOLE DIM (X) :
ONE-PLACE (X.X) :
TWO-PLACE (X.XX) :
ANGLE :
THIRD ANGLE PROJECTION

DO NOT SCALE DRAWING

TITLE: WIRING INSTL-BODY, 110V

SHEET 1 OF 3 PART NO 148962

REF: 146052 1 11/19/2004

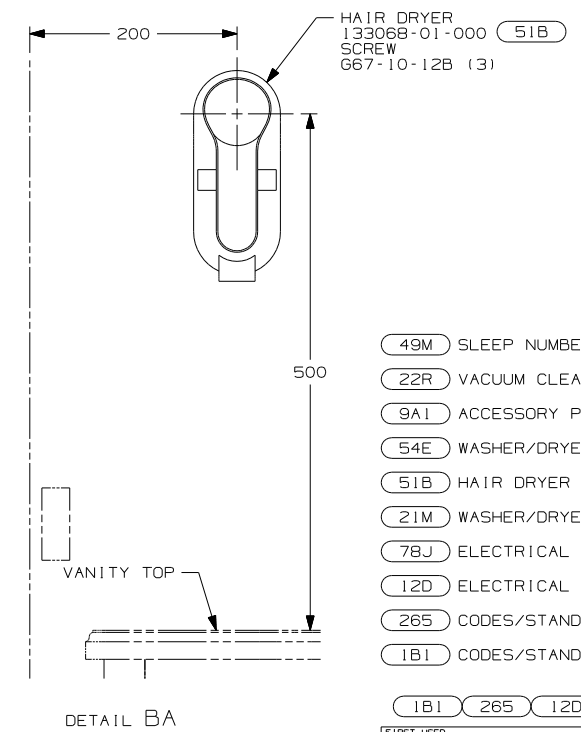
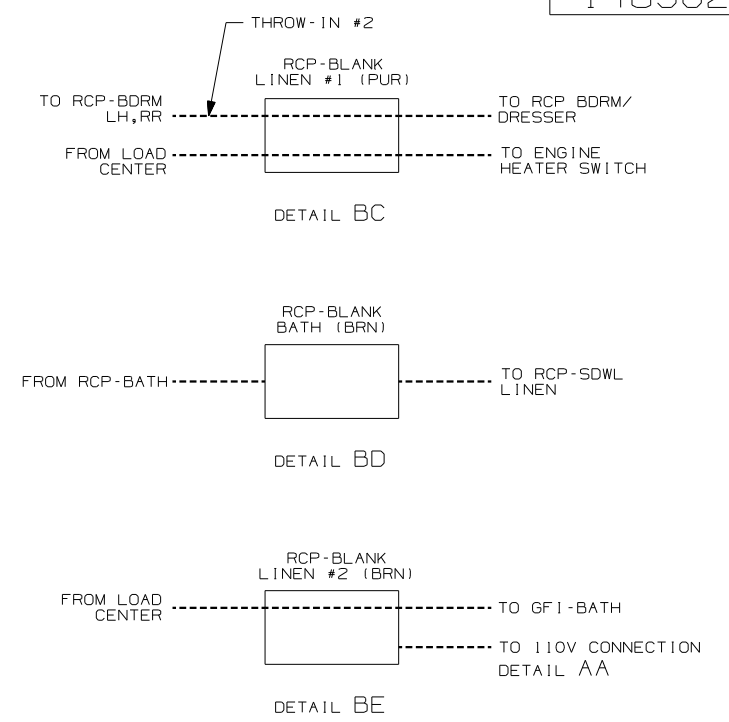
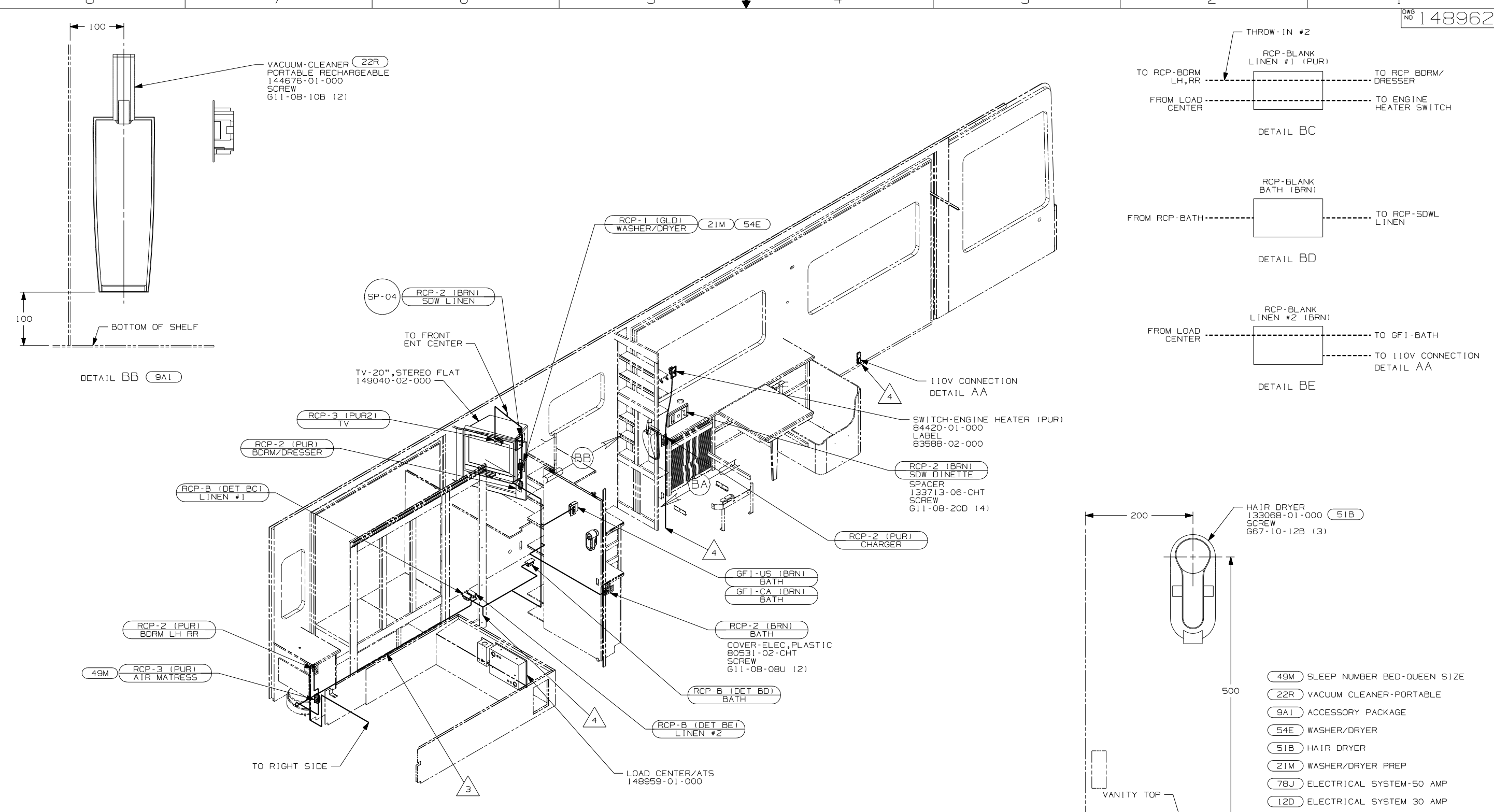

- (49M) SLEEP NUMBER BED-QUEEN SIZE
- (22R) VACUUM CLEANER-PORTABLE
- (9A1) ACCESSORY PACKAGE
- (54E) WASHER/DRYER
- (51B) HAIR DRYER
- (21M) WASHER/DRYER PREP
- (78J) ELECTRICAL SYSTEM-50 AMP
- (12D) ELECTRICAL SYSTEM 30 AMP
- (265) CODES/STANDARDS-CSA/CMVSS
- (1B1) CODES/STANDARDS USA

- NOTES:
- 4 WIRES ROUTE UP THRU FLOOR IN THIS AREA.
 - 3 ROUTE WIRE IN FLOOR
 2. ALL WIRES ARE TO BE CLAMPED WITH CLAMP 10497-05-000 WITHIN 200 FO OUTLET BOXES AND SPLICES. USE SCREW 667-10-12B
 1. ALL WIRES TO BE SECURED WITH CLAMP 10495 OR 10497 OR WIRE TIE 8343 OR 108046 EVERY 600MM, USE SCREW 667-XX-XXX OR G56-XX-XXX AS APPROPRIATE FOR INTALLATION.

FOR ELECTRICAL TORQUE SPECIFICATIONS SEE DWG NO. 128783-01-000	(X-X)	FOR ELECTRICAL CALLOUTS SEE DWG NO. 121339-01-000
--	-------	---

FIRST USED	05 P36G
DO NOT SCALE DRAWING	
TITLE: WIRING INSTL-BODY, 110V	
SHEET 2	PART NO 148962

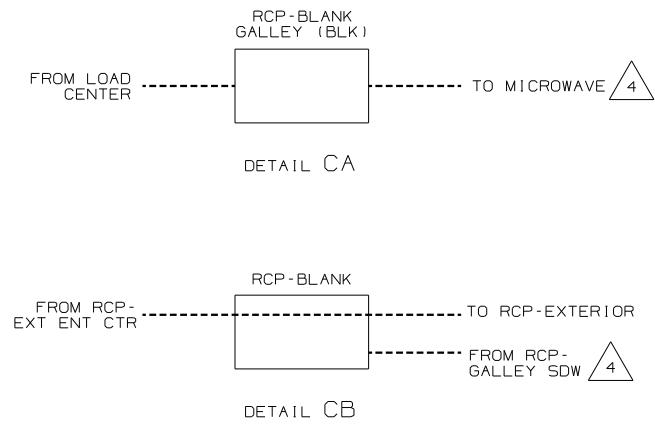
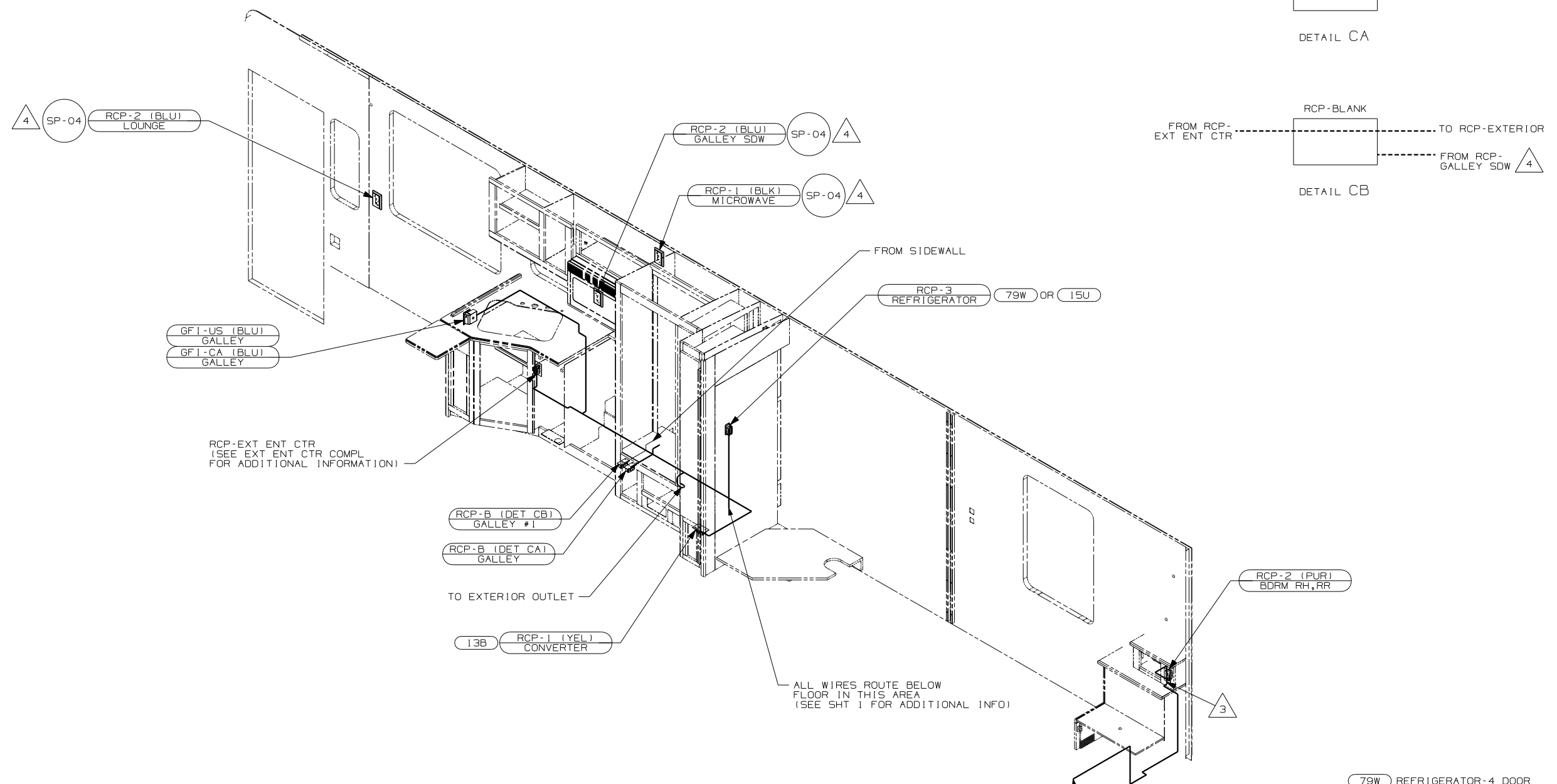

- 4 WIRE IN SIDEWALL
- 3 ROUTE WIRE IN SIDEWALL DURING INSTALLATION.

2. ALL WIRES ARE TO BE CLAMPED WITH CLAMP 10497-05-000. WITHIN 200 FO OUTLET BOXES AND SPLICES, USE SCREW G67-10-12B.
1. ALL WIRES TO BE SECURED WITH CLAMP 10495 OR 10497 OR WIRE TIE 8343 OR 108046 EVERY 600MM, USE SCREW G67-XX-XXX OR G56-XX-XXX AS APPROPRIATE FOR INTALLATION.

NOTES:

- 79W REFRIGERATOR-4 DOOR
- 13B INVERTER/CHARGER-DC/AC W/O
- 15U REFRIGERATOR/FRZR W/ICEMAKER
- 78J ELECTRICAL SYSTEM-50 AMP
- 12D ELECTRICAL SYSTEM 30 AMP
- 265 CODES/STANDARDS-CSA/CMVSS
- 1B1 CODES/STANDARDS USA

FIRST USED	
05 P36G	
DO NOT SCALE DRAWING	
TITLE:	
WIRING INSTL-BODY,110V	
SHEET 3	PART NO
	148962

FOR ELECTRICAL TORQUE SPECIFICATIONS SEE DWG NO. 128783-01-000

FOR ELECTRICAL CALLOUTS SEE DWG NO. 121339-01-000