



DANGER

Danger of electrical shock, burns or death. Always remove all power sources before attempting any repair, service or diagnostic work. Power can be present from shore power, generator, inverter or battery. All power sources must be disabled and secured before performing any service.



CAUTION

If you lack the skills, tools or equipment to perform diagnostic or repair work leave such work to an authorized Winnebago Industries dealer or other qualified shop.

CHASSIS ELECTRICAL BOX

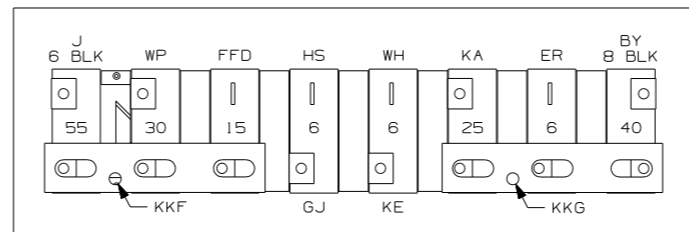

- J 6 BLK
- WP 10 YEL
- FFD 12 YEL
- HS 16 YEL
- WH 14 YEL
- KA 12 YEL
- ER 16 YEL
- BY 8 BLK
- GJ 16 YEL
- KE 14 YEL
- KKF 6 BLK
- KKG 8 BLK

CONNECTS TO WIRE ASM-CHASSIS (SHT 1, D-24) (LOCATED IN CHASSIS BREAKER PANEL)

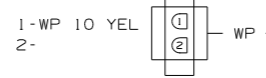

CONNECTS TO WIRE ASM-CHASSIS (SHT 1, C-10) (LOCATED IN CHASSIS BREAKER PANEL)

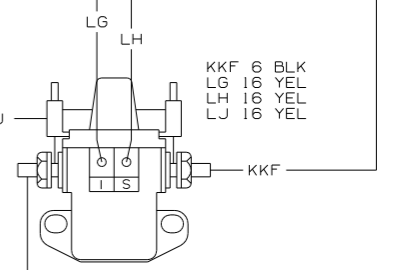
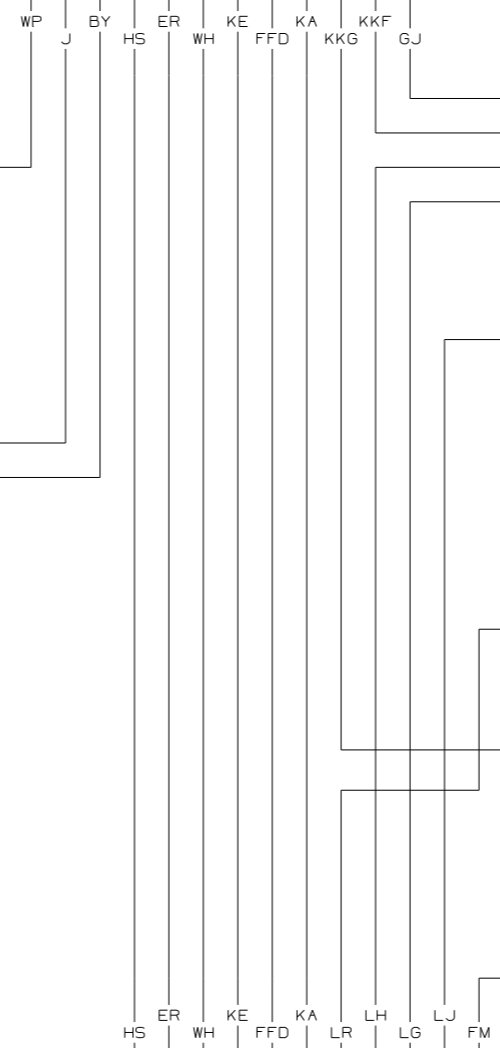
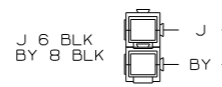

BATTERY DISCONNECT RELAY

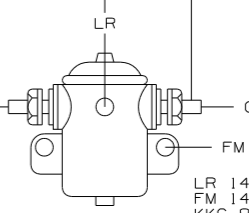

BATTERY MODE SOLENOID

- KKF 6 BLK
- LG 16 YEL
- LH 16 YEL
- LJ 16 YEL

- LR 14 YEL
- FM 14 WHT
- KKG 8 BLK

- 1-
- 2-
- 3-ER 16 YEL
- 4-
- 5-LG 16 YEL
- 6-FM 14 WHT
- 7-LR 14 YEL
- 8-HS 16 YEL
- 9-WH 14 YEL
- 10-KE 14 YEL
- 11-LH 16 YEL
- 12-
- 13-LJ 16 YEL
- 14-FFD 12 YEL
- 15-KA 12 YEL

CONNECTS TO WIRE ASM-CHASSIS (SHT 1, A-13) (LOCATED IN CHASSIS BREAKER PANEL)

WIRING DIAGRAM-ELECTRICAL BOX (WIRE ASM 124125-03 REV-L)

WINNEBAGO		COPYRIGHT 2004 WINNEBAGO INDUSTRIES, INC.	
DFTR	ORIG. DATE	ALL DIMENSIONS ARE IN MILLIMETERS	
CHNR		M.E.	
P.E.		FIRST USED	
M.E.		05 G37B	
DSNR		UNSPECIFIED TOLERANCES ARE:	
		MATERIAL:	
		THIRD ANGLE PROJECTION	
DO NOT SCALE DRAWING			
TITLE: WIRING DIAGRAM-BODY, 12V			
SHEET 1 of 6		PART NO 150757	

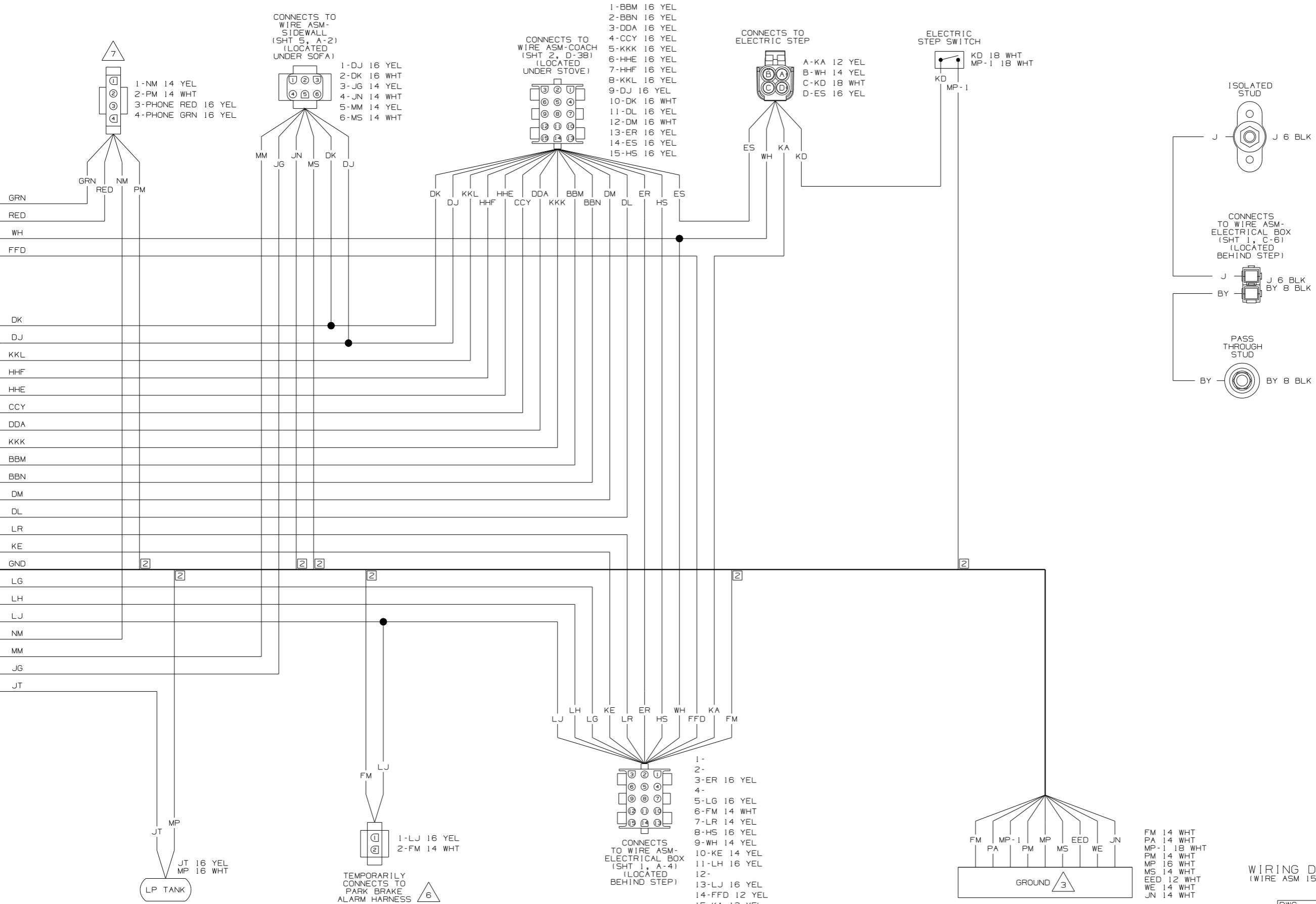

WIRING DIAGRAM-CHASSIS (WIRE ASM 150889 REV-B)

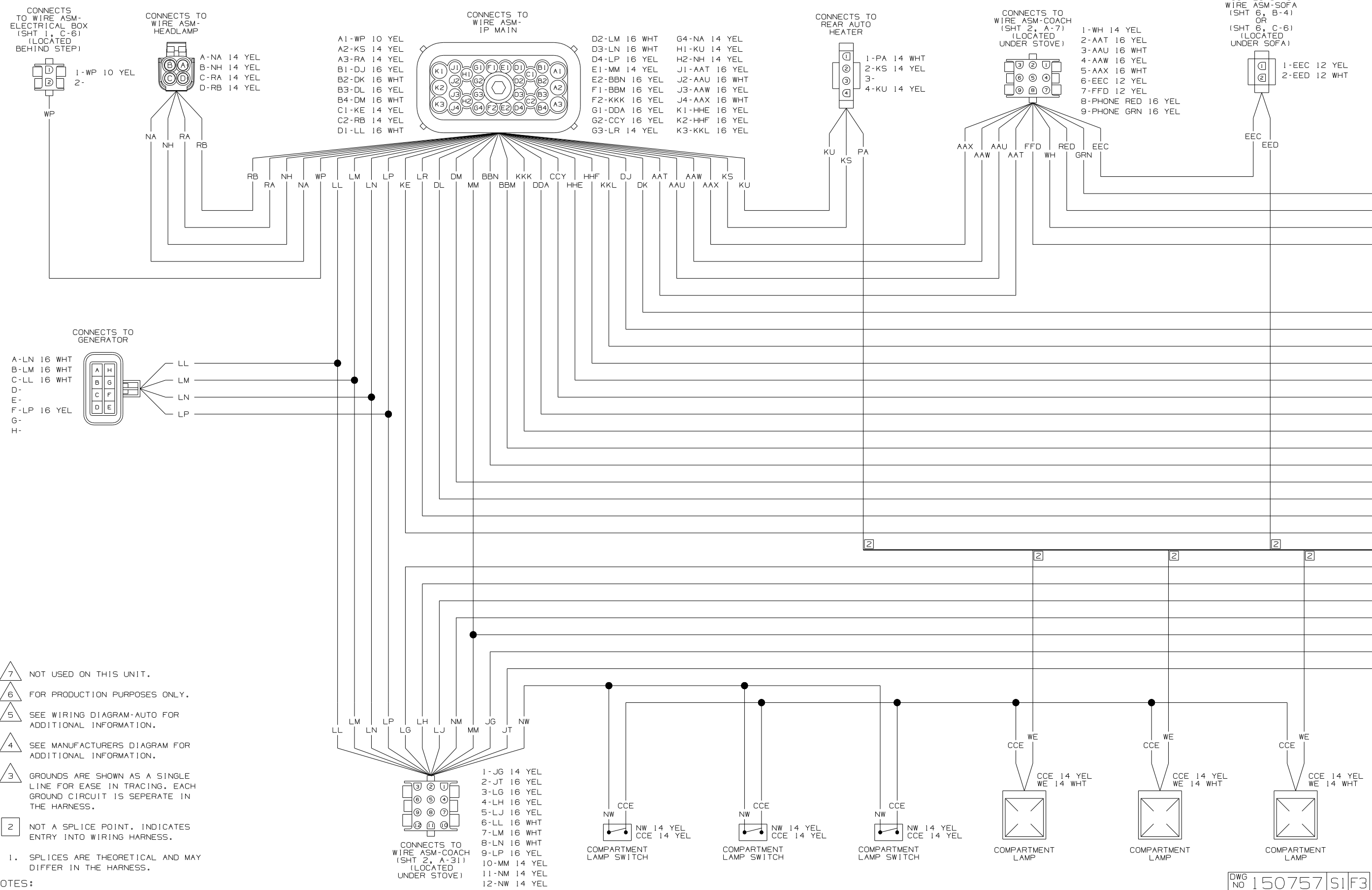

- 7 NOT USED ON THIS UNIT.
- 6 FOR PRODUCTION PURPOSES ONLY.
- 5 SEE WIRING DIAGRAM-AUTO FOR ADDITIONAL INFORMATION.
- 4 SEE MANUFACTURERS DIAGRAM FOR ADDITIONAL INFORMATION.
- 3 GROUNDS ARE SHOWN AS A SINGLE LINE FOR EASE IN TRACING. EACH GROUND CIRCUIT IS SEPERATE IN THE HARNESS.
- 2 NOT A SPLICE POINT. INDICATES ENTRY INTO WIRING HARNESS.

1. SPLICES ARE THEORETICAL AND MAY DIFFER IN THE HARNESS.

NOTES:

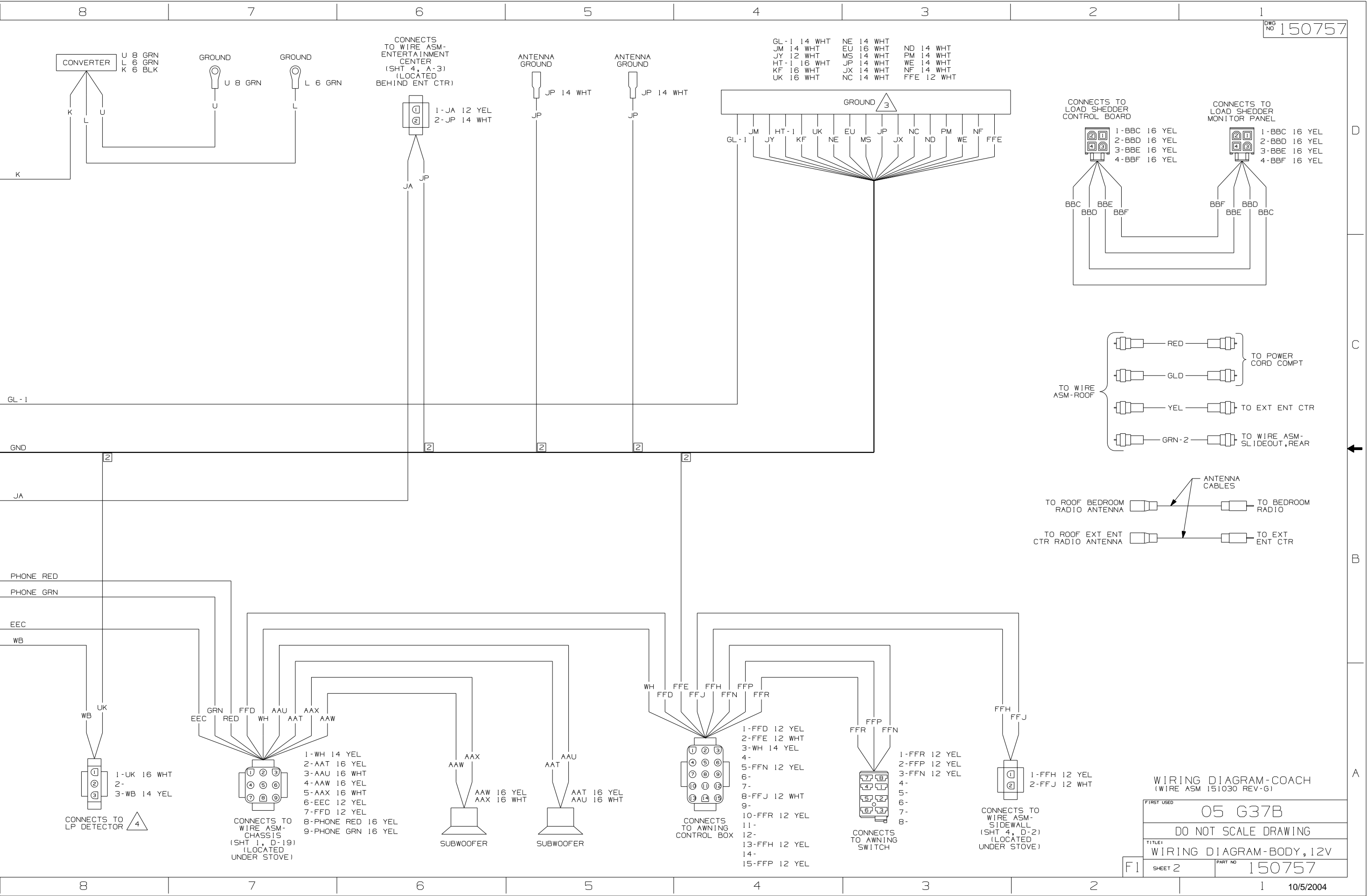

- GL-1 14 WHT
- JM 14 WHT
- JY 12 WHT
- HT-1 16 WHT
- KF 16 WHT
- UK 16 WHT
- NE 14 WHT
- EU 16 WHT
- MS 14 WHT
- JP 14 WHT
- JX 14 WHT
- NC 14 WHT
- ND 14 WHT
- PM 14 WHT
- WE 14 WHT
- NF 14 WHT
- FFE 12 WHT

- CONNECTS TO LOAD SHEDDER CONTROL BOARD
- 1-BBC 16 YEL
 - 2-BBD 16 YEL
 - 3-BBE 16 YEL
 - 4-BBF 16 YEL
- CONNECTS TO LOAD SHEDDER MONITOR PANEL
- 1-BBC 16 YEL
 - 2-BBD 16 YEL
 - 3-BBE 16 YEL
 - 4-BBF 16 YEL

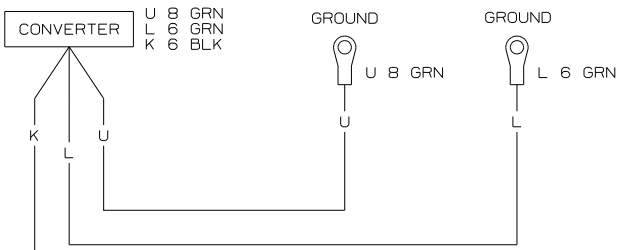
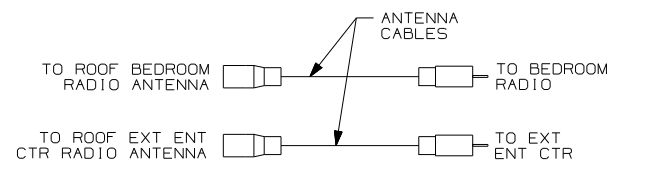
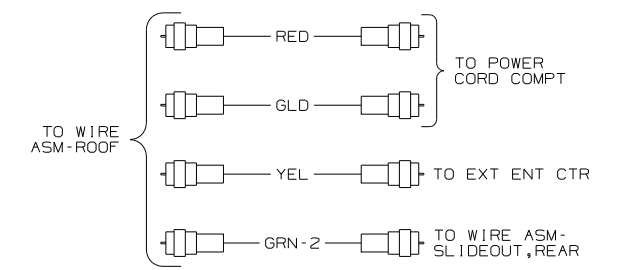

CONNECTS TO WIRE ASM-ENTERTAINMENT CENTER (SHT 4, A-3) (LOCATED BEHIND ENT CTR)

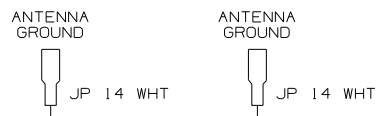

- GL-1
- JM
- JY
- HT-1
- KF
- UK
- NE
- EU
- MS
- JP
- JX
- NC
- ND
- PM
- WE
- NF
- FFE

GL-1

GND

JA

PHONE RED

PHONE GRN

EEC

WB

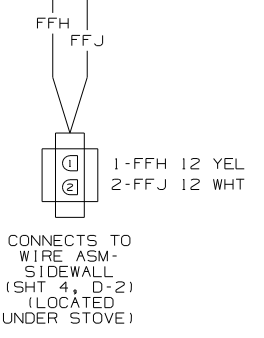
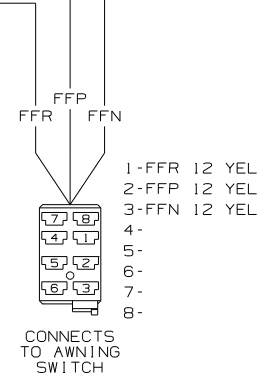
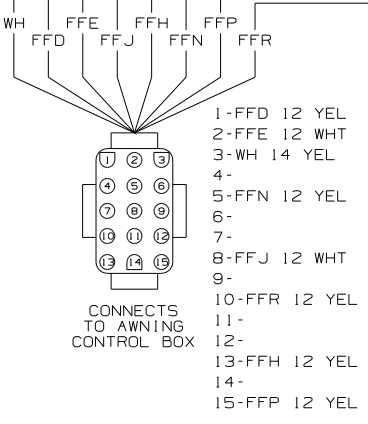
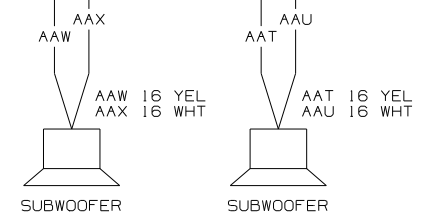
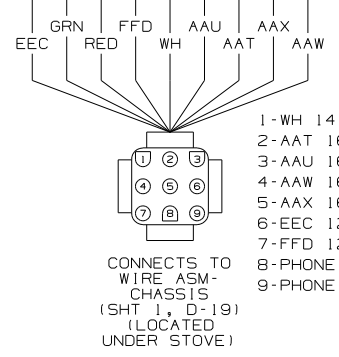
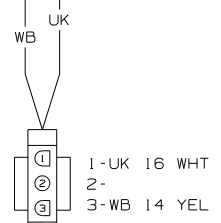

WIRING DIAGRAM-COACH (WIRE ASM 151030 REV-G)

FIRST USED 05 G37B

DO NOT SCALE DRAWING

TITLE: WIRING DIAGRAM-BODY, 12V

SHEET 2 PART NO 150757

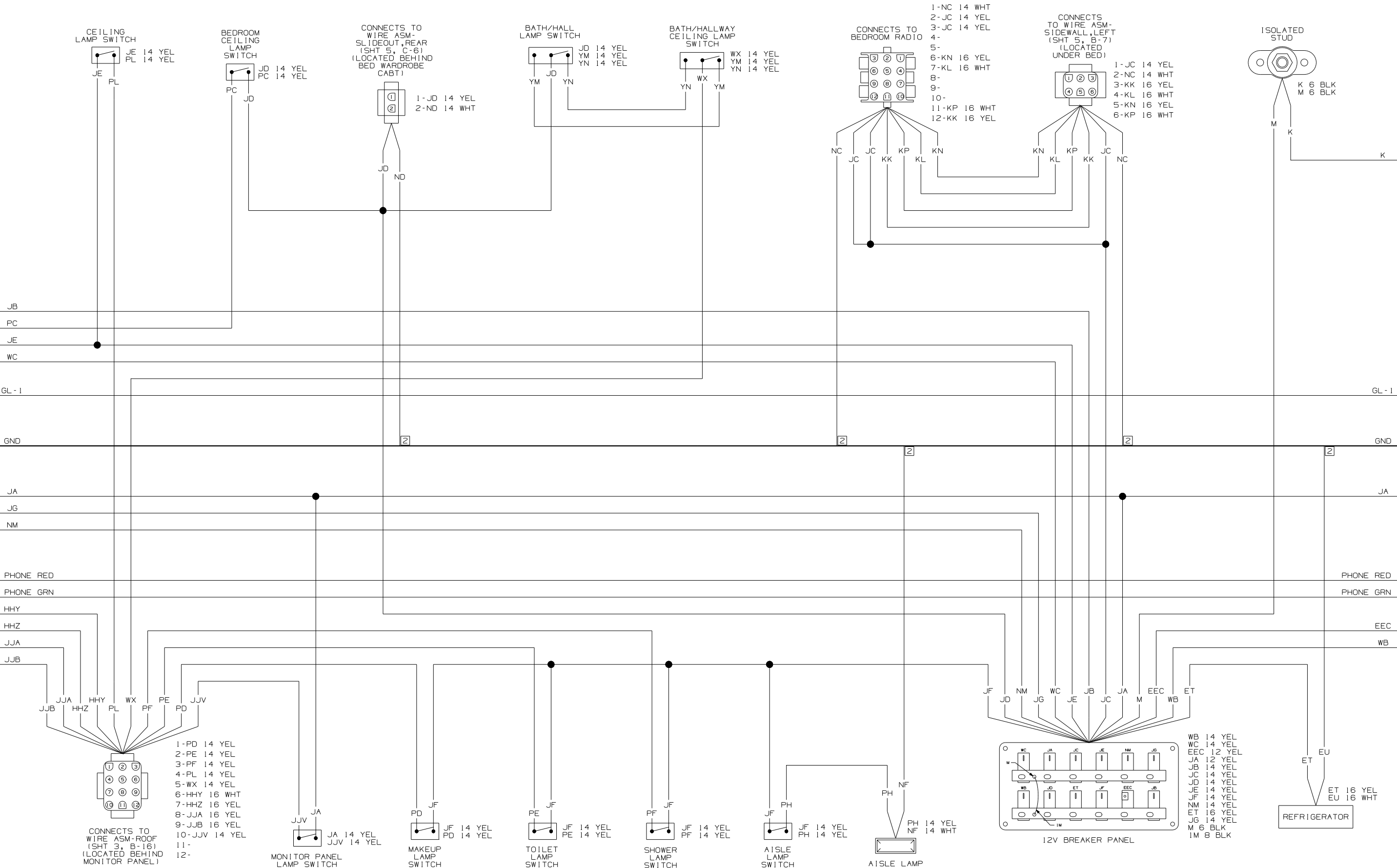

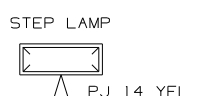

CONNECTS TO WIRE ASM-SIDEWALL (SHT 4, D-6) (LOCATED BEHIND GALLEY)

- 1-DL 16 YEL
- 2-DM 16 WHT
- 3-JE 14 YEL
- 4-MM 14 YEL
- 5-MS 14 WHT
- 6-NE 14 WHT
- 7-NM 14 YEL
- 8-PJ 14 YEL
- 9-PM 14 WHT
- 10-WE 14 WHT
- 11-PHONE RED 16 YEL
- 12-PHONE GRN 16 YEL

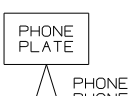

PHONE RED 16 YEL
PHONE GRN 16 YEL

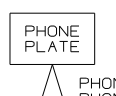

PHONE RED 16 YEL
PHONE GRN 16 YEL

CONNECTS TO WIRE ASM-ROOF (SHT 3, C-16) (LOCATED BEHIND MONITOR PANEL)

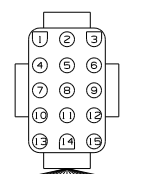

- 1-A 14 YEL
- 2-DL 16 YEL
- 3-DM 16 WHT
- 4-HS 16 YEL
- 5-HT 16 WHT
- 6-JA 12 YEL
- 7-JB 14 YEL
- 8-JM 14 WHT
- 9-JP 14 WHT
- 10-KG 14 YEL
- 11-KH 14 YEL
- 12-ND 14 WHT
- 13-NE 14 WHT
- 14-NF 14 WHT
- 15-PC 14 YEL

CONNECTS TO SOLAR PANEL

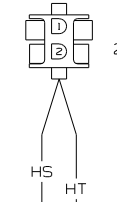

- 1-HS 16 YEL
- 2-HT 16 YEL

TOILET FAN SWITCH

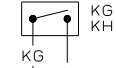

- KG 14 YEL
- KH 14 YEL

GALLEY CEILING LAMP SWITCH



- A 14 YEL
- JE 14 YEL

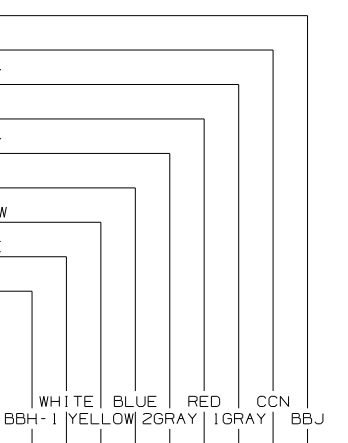
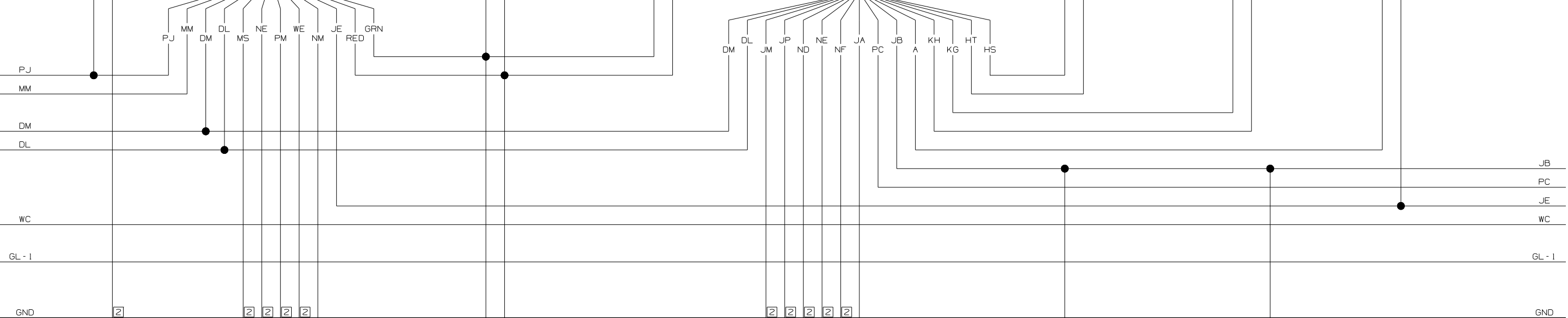

- 1-IGRAY 16 YEL
- 2-RED 16 YEL
- 3-2GRAY 16 YEL
- 4-BLUE 16 YEL
- 5-YELLOW 16 YEL
- 6-BBH-1 16 YEL
- 7-BBJ 16 YEL
- 8-WHITE 16 YEL
- 9-CCN 16 YEL

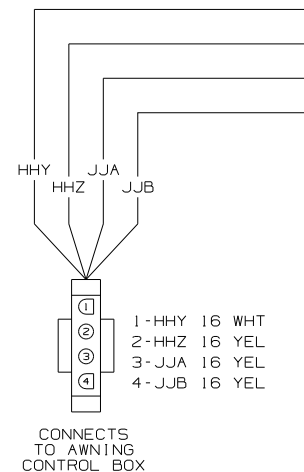
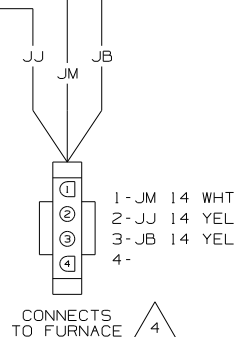
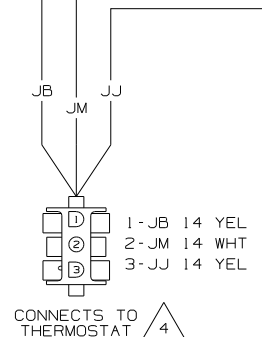
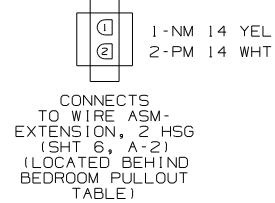
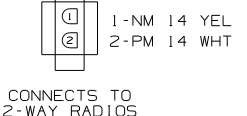
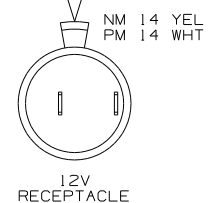
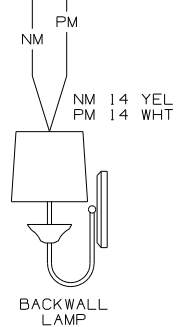
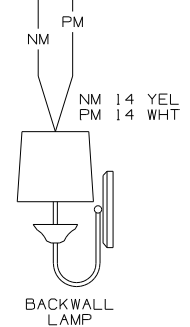

- 1-HHY 16 WHT
- 2-HHZ 16 YEL
- 3-JJA 16 YEL
- 4-JJB 16 YEL

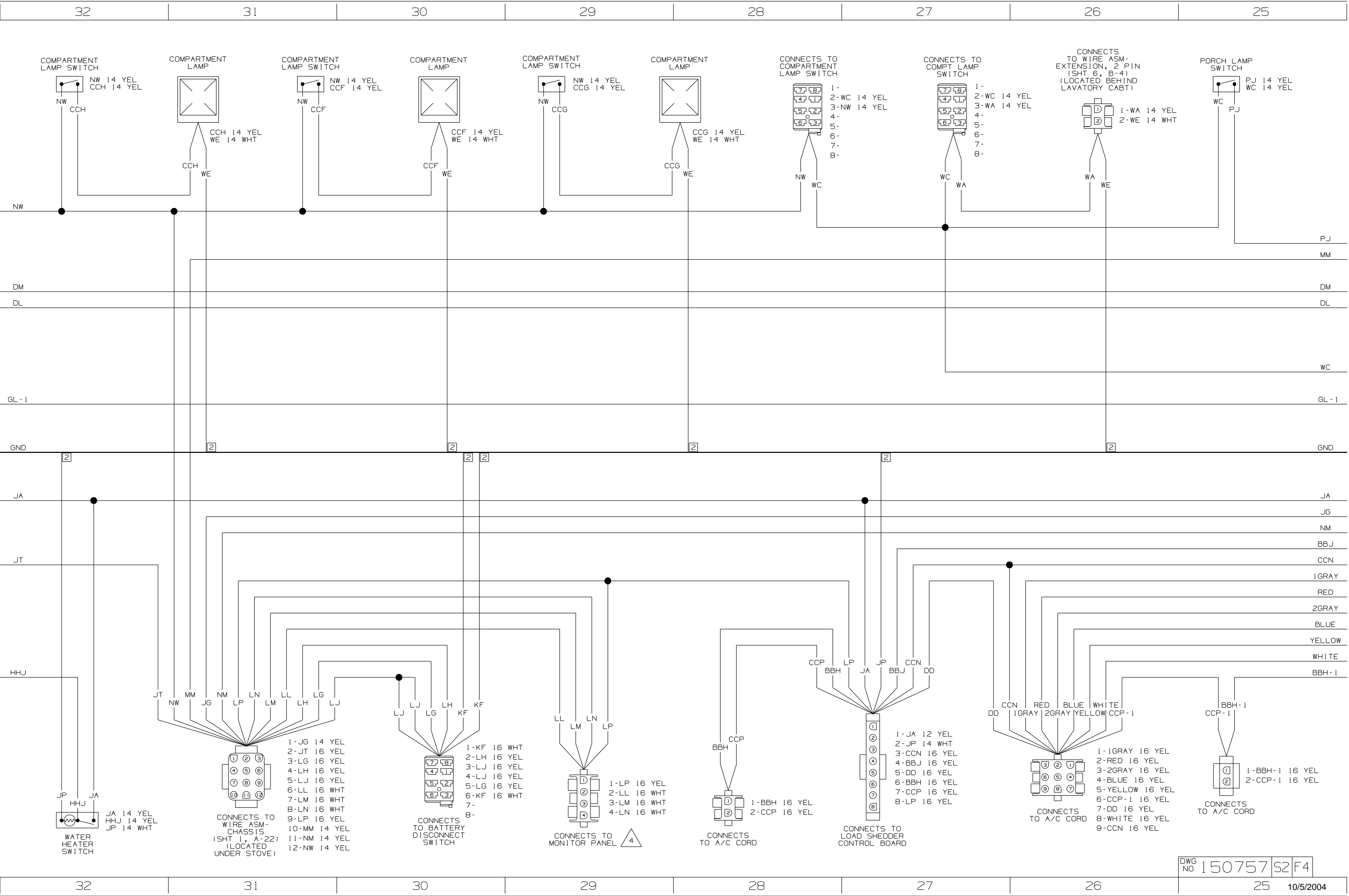

CONNECTS TO SLIDEOUT CONTROL LEFT, REAR SWITCH

CONNECTS TO SLIDEOUT CONTROL RIGHT, REAR SWITCH

CONNECTS TO WIRE ASM-CHASSIS (SHT 1, D-13) (LOCATED UNDER STOVE)

ELECTRIC STEP KILL SWITCH

CONNECTS TO SOLAR PANEL 

COMPARTMENT LAMP SWITCH

COMPARTMENT LAMP

COMPARTMENT LAMP SWITCH

COMPARTMENT LAMP

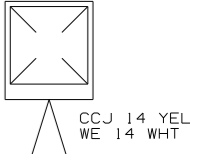
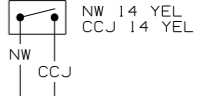
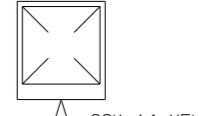
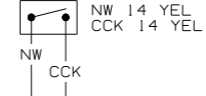
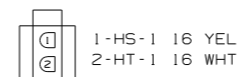
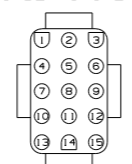
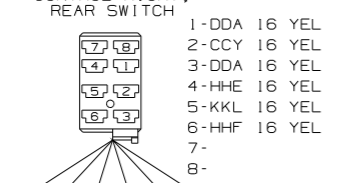
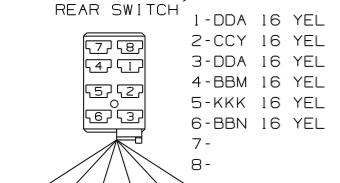

BBM KKK DDA DDA

CCY DDA HHE KKL

KKL HHF HHE DDA KKK BBN DL DM HS-1 ES

HS-1 HT-1

NW CCK

CCK WE

NW CCJ

CCJ WE

NW

DM

DL

GL-1

GND

JA

JT

HHJ

 GL AND GL-1 ARE TO BE SPLICED TOGETHER 100MM AWAY FROM MONITOR PANEL HOUSING FOR ISOLATION PURPOSES.

 SEE WIRING DIAGRAM-AUTO FOR ADDITIONAL INFORMATION.

 SEE MANUFACTURERS DIAGRAM FOR ADDITIONAL INFORMATION.

 GROUNDS ARE SHOWN AS A SINGLE LINE FOR EASE IN TRACING. EACH GROUND CIRCUIT IS SEPERATE IN THE HARNESS.

 NOT A SPLICE POINT. INDICATES ENTRY INTO WIRING HARNESS.

1. SPLICES ARE THEORETICAL AND MAY DIFFER IN THE HARNESS.

NOTES:

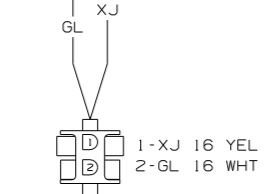

CONNECTS TO WIRE ASM-MAIN HOLDING TANK

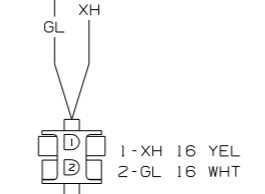

CONNECTS TO WIRE ASM-WATER TANK



XH XJ AF GL JA JT JU JW ER AG JS XK

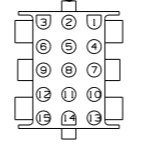

 CONNECTS TO MONITOR PANEL

1-JA 12 YEL
2-ER 16 YEL
3-GL 16 WHT
4-XH 16 YEL
5-XJ 16 YEL
6-XK 16 YEL
7-AG 12 YEL
8-JS 12 YEL
9-AF 12 YEL
10-
11-
12-JT 16 YEL
13-JW 14 YEL
14-
15-JU 14 YEL

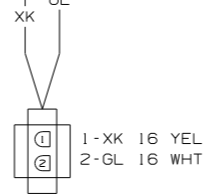

CONNECTS TO WIRE ASM-AUX HOLDING TANK

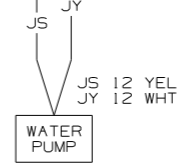

WATER PUMP

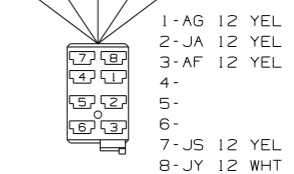

CONNECTS TO EXTERIOR WATER PUMP SWITCH

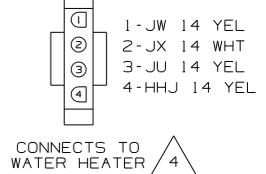

CONNECTS TO WATER HEATER 

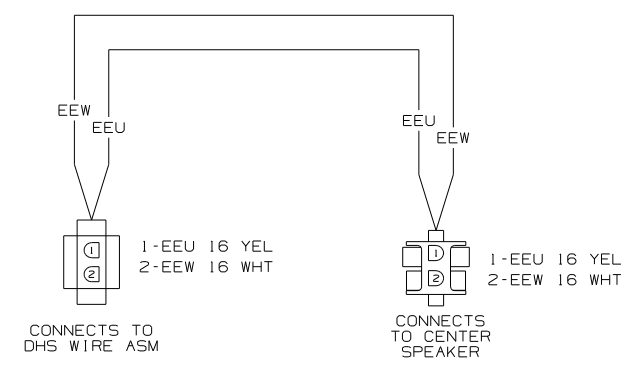
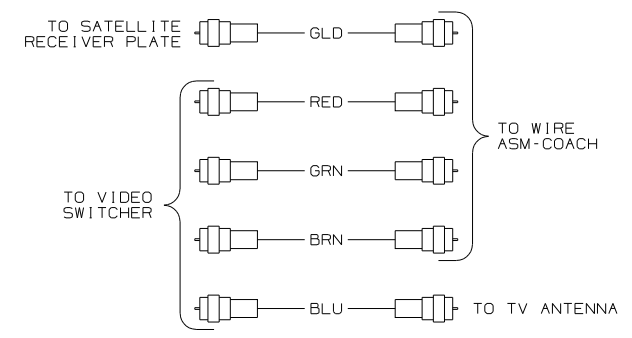
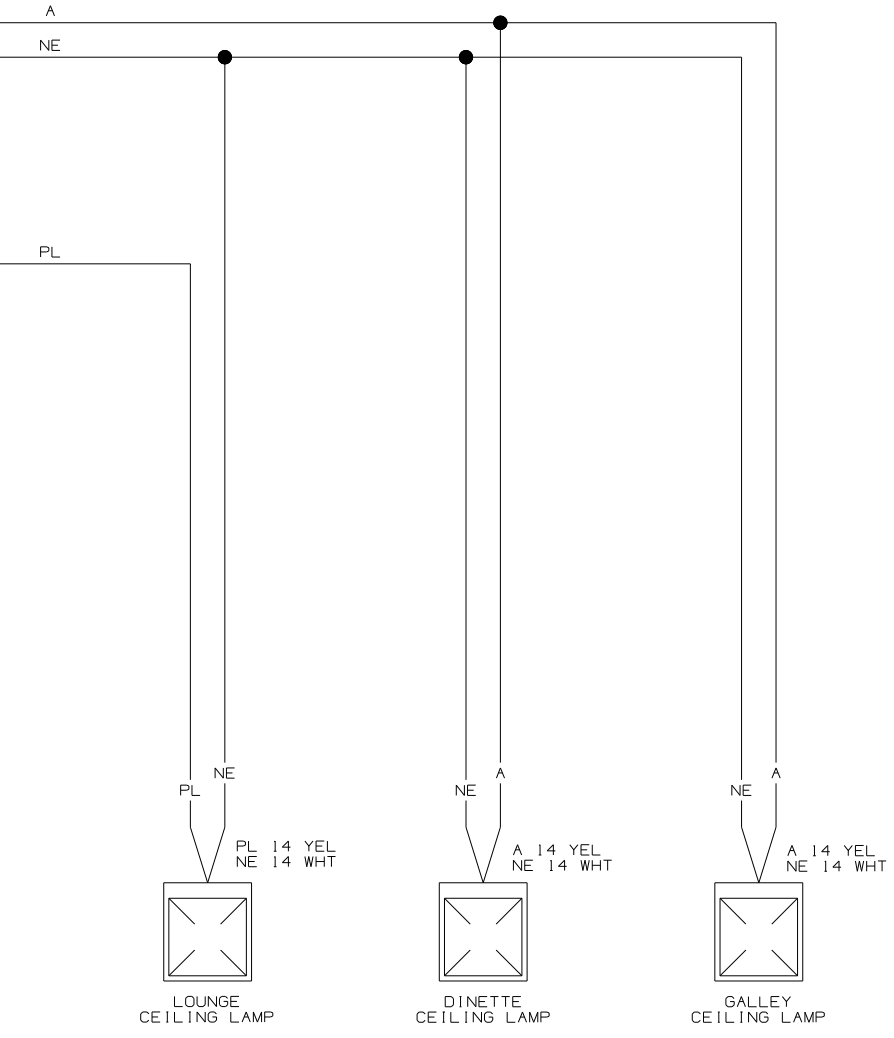
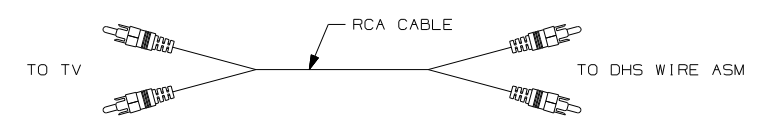
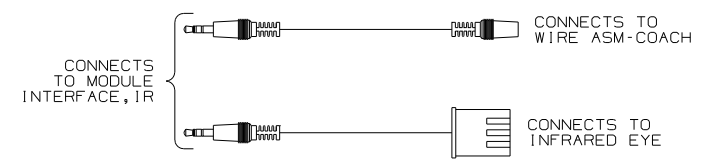
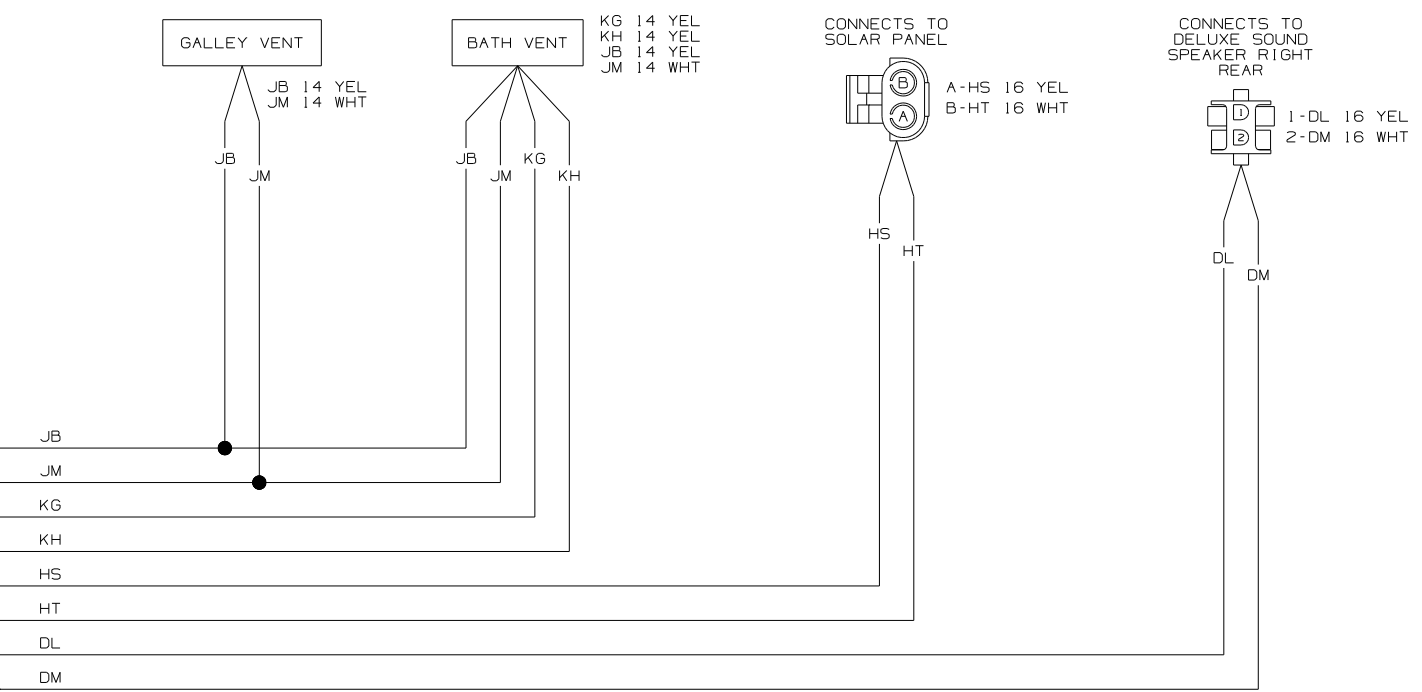

WIRING DIAGRAM-ROOF
 (WIRE ASM 150963 REV-H)

FIRST USED	05 G37B	
DO NOT SCALE DRAWING		
TITLE	WIRING DIAGRAM-BODY, 12V	
SHEET 3	PART NO	150757

D
C
B
A

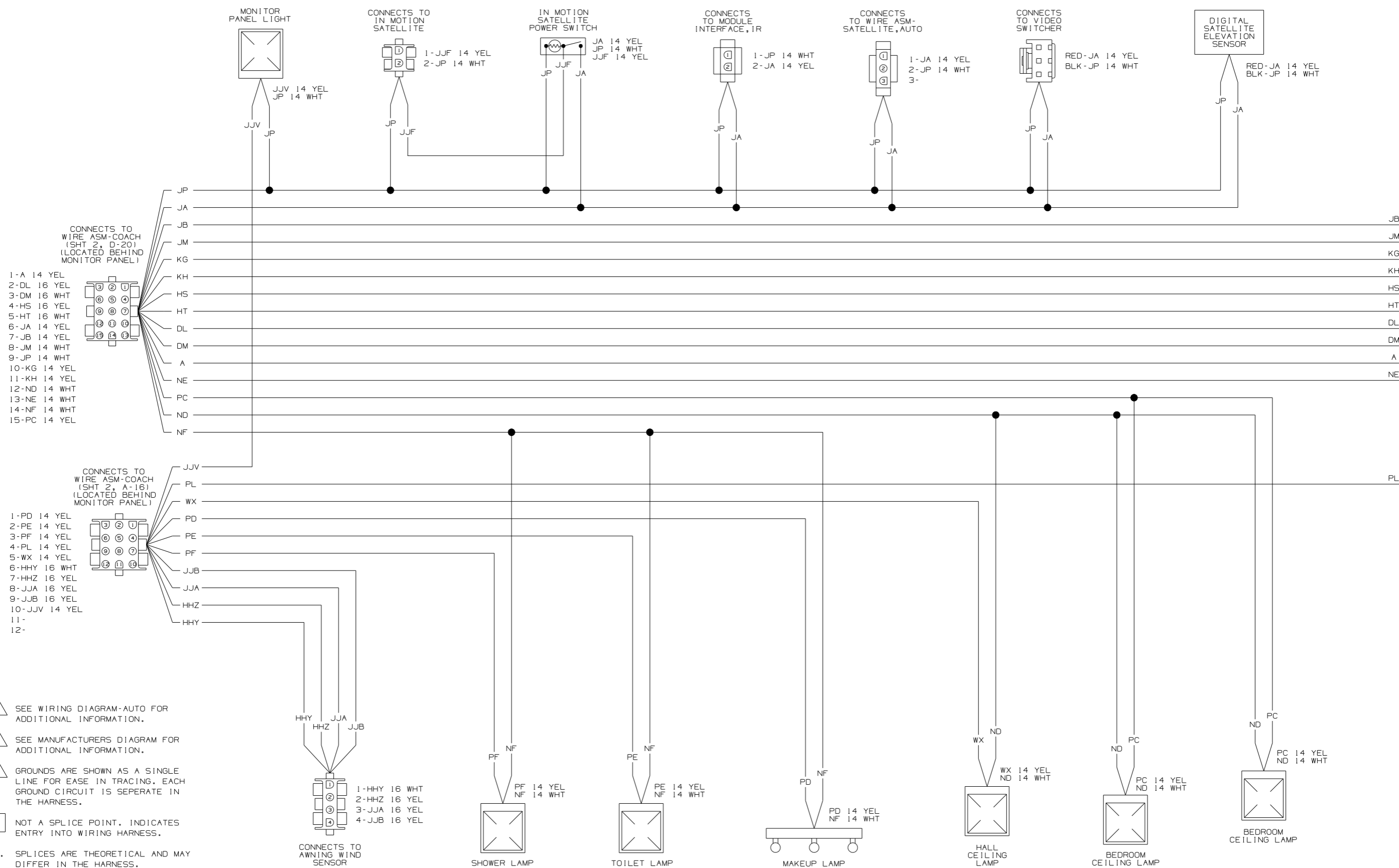

- 5 SEE WIRING DIAGRAM-AUTO FOR ADDITIONAL INFORMATION.
- 4 SEE MANUFACTURERS DIAGRAM FOR ADDITIONAL INFORMATION.
- 3 GROUNDS ARE SHOWN AS A SINGLE LINE FOR EASE IN TRACING. EACH GROUND CIRCUIT IS SEPERATE IN THE HARNESS.
- 2 NOT A SPLICE POINT. INDICATES ENTRY INTO WIRING HARNESS.
1. SPLICES ARE THEORETICAL AND MAY DIFFER IN THE HARNESS.

NOTES:

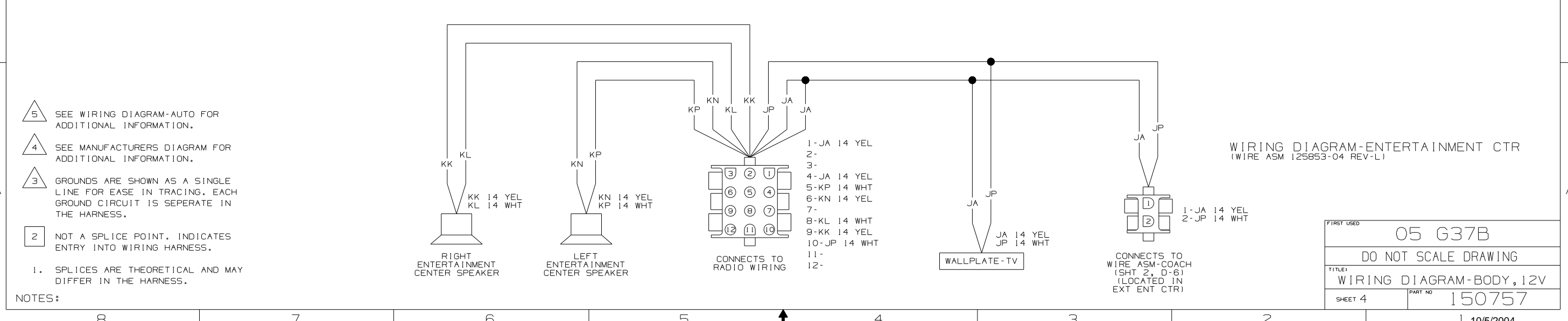
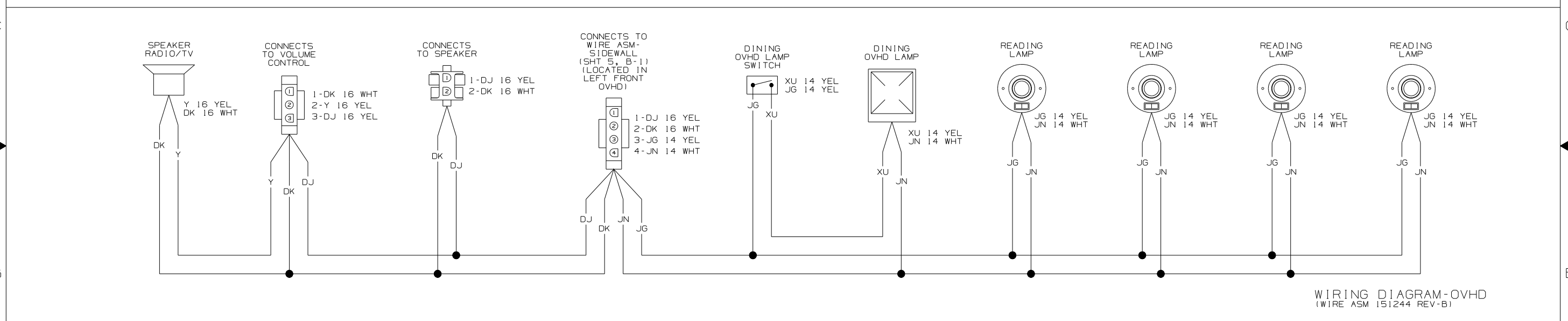
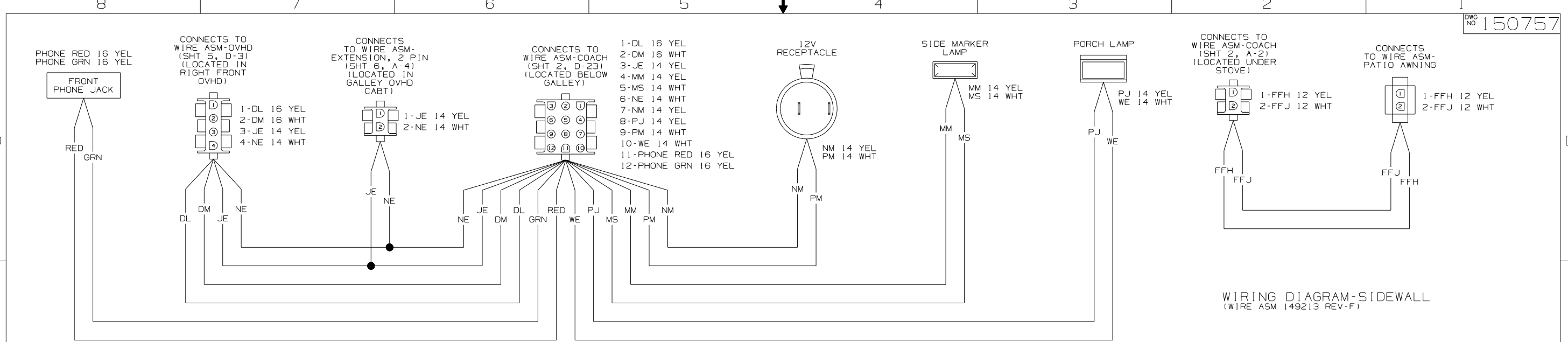

- NOTES:**
- 5 SEE WIRING DIAGRAM-AUTO FOR ADDITIONAL INFORMATION.
 - 4 SEE MANUFACTURERS DIAGRAM FOR ADDITIONAL INFORMATION.
 - 3 GROUNDS ARE SHOWN AS A SINGLE LINE FOR EASE IN TRACING. EACH GROUND CIRCUIT IS SEPERATE IN THE HARNESS.
 - 2 NOT A SPLICE POINT. INDICATES ENTRY INTO WIRING HARNESS.
 - 1. SPLICES ARE THEORETICAL AND MAY DIFFER IN THE HARNESS.

FIRST USED	05 G37B
DO NOT SCALE DRAWING	
TITLE:	WIRING DIAGRAM-BODY, 12V
SHEET 4	PART NO 150757

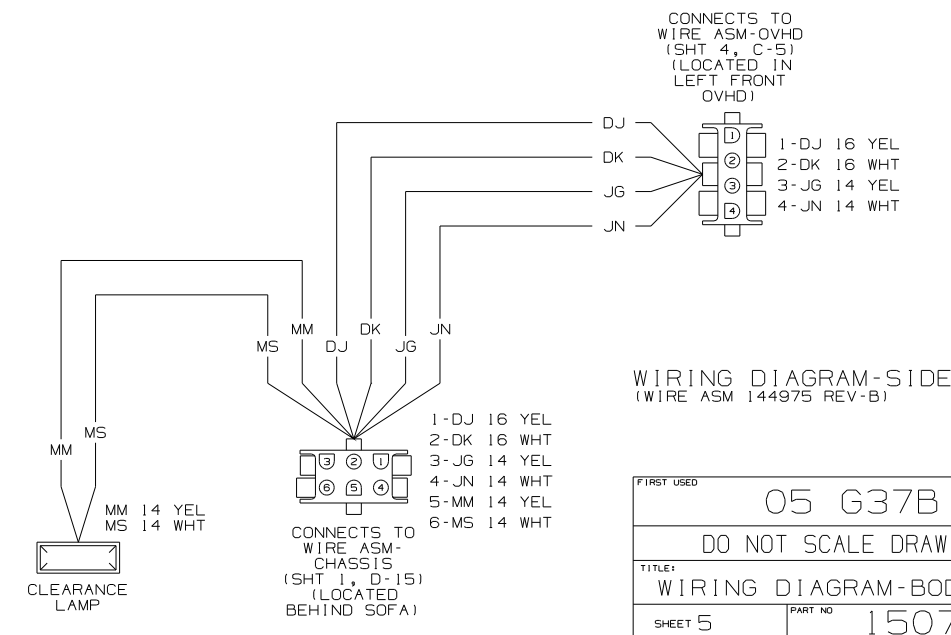
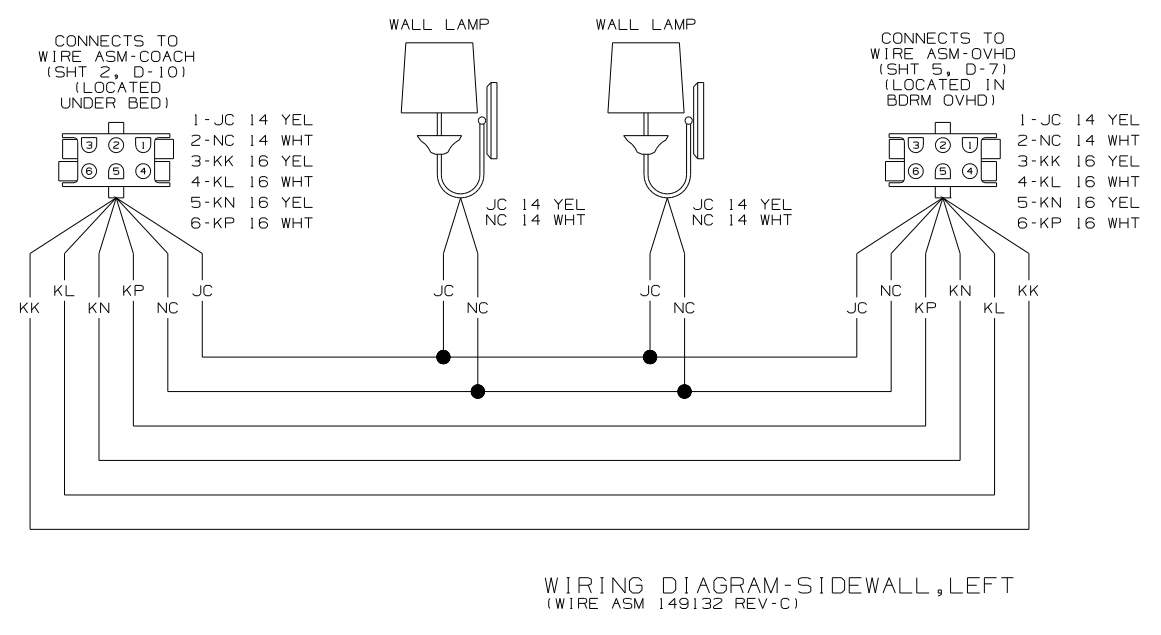
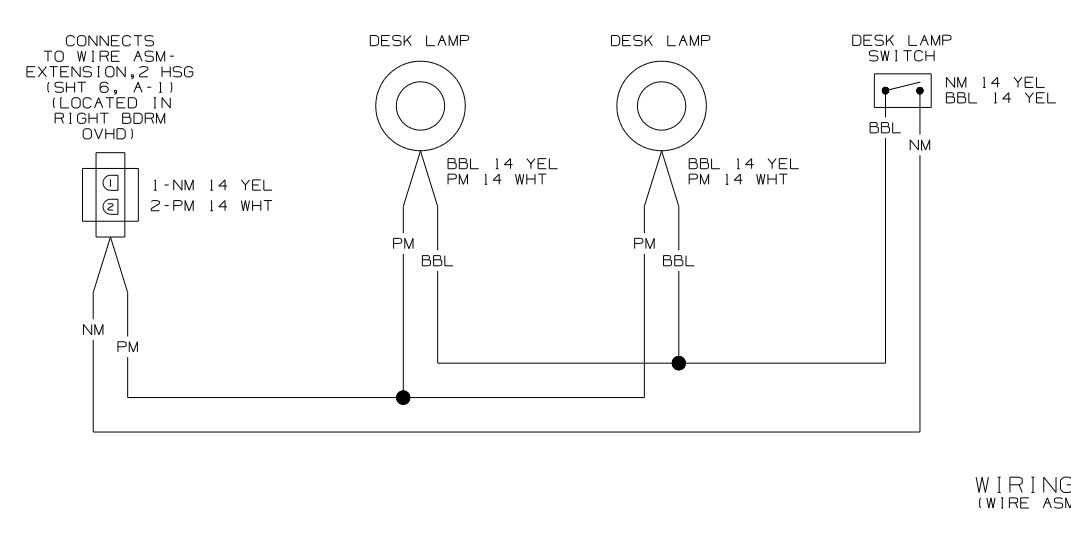
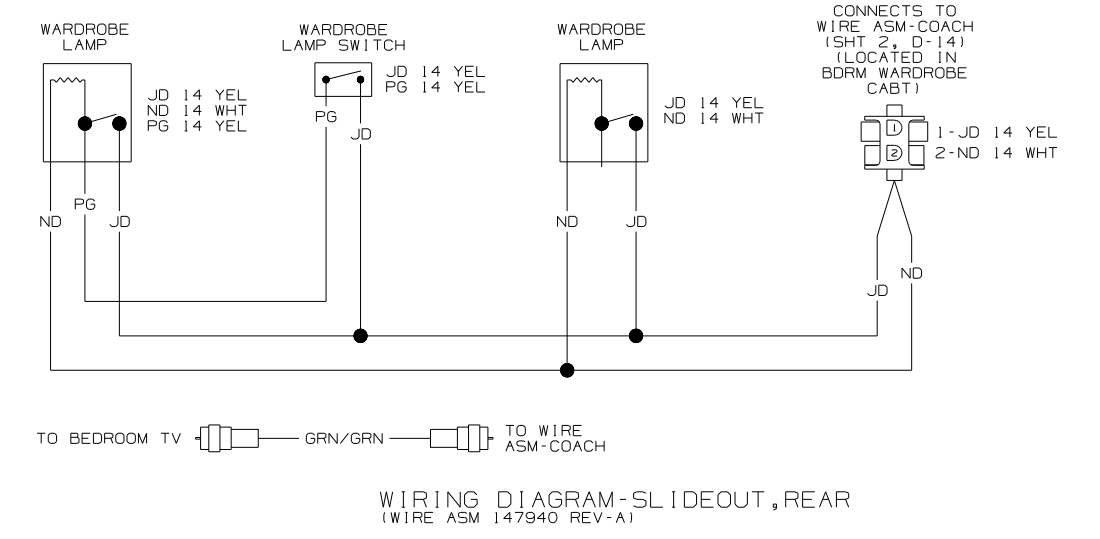
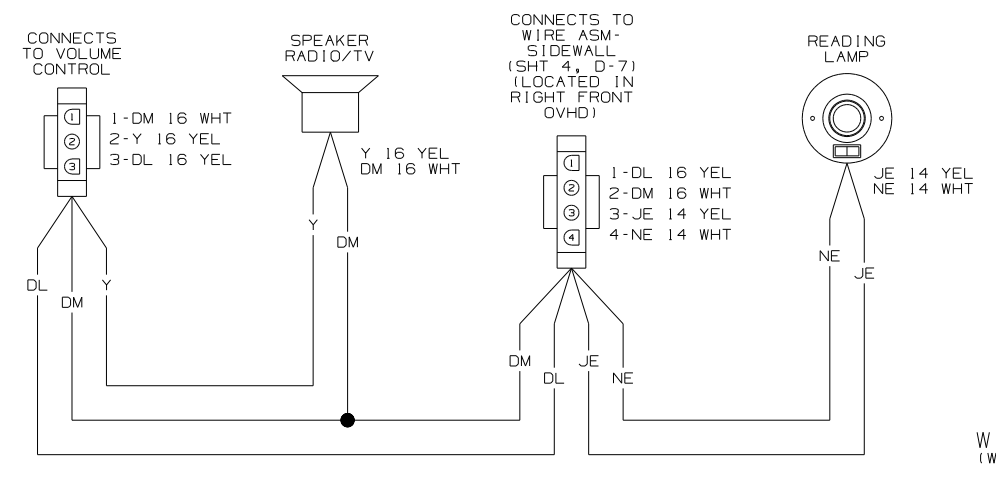
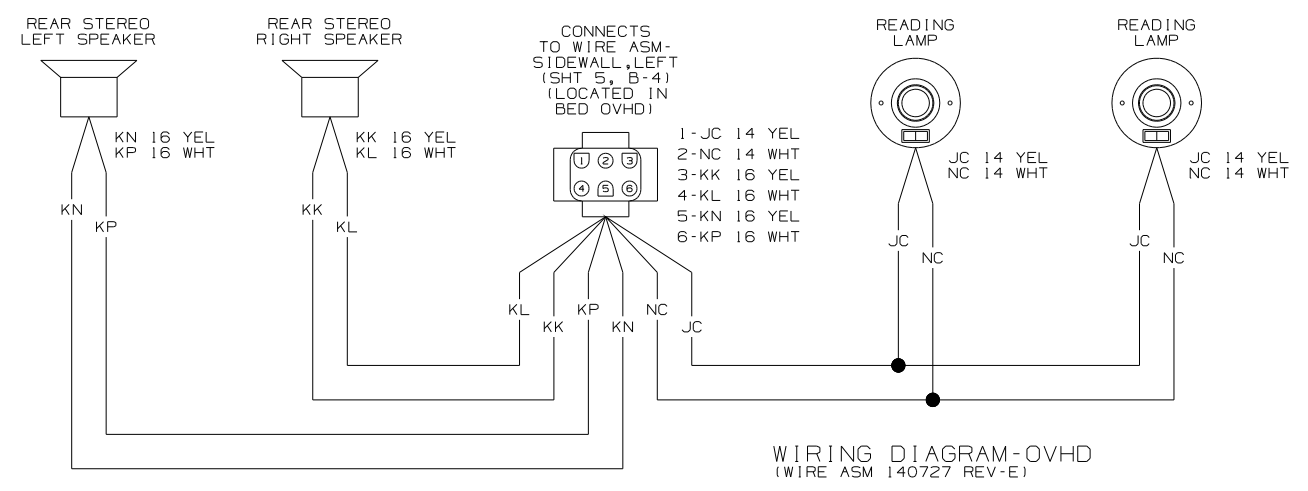

- NOTES:
- 5 SEE WIRING DIAGRAM-AUTO FOR ADDITIONAL INFORMATION.
 - 4 SEE MANUFACTURERS DIAGRAM FOR ADDITIONAL INFORMATION.
 - 3 GROUNDS ARE SHOWN AS A SINGLE LINE FOR EASE IN TRACING. EACH GROUND CIRCUIT IS SEPERATE IN THE HARNESS.
 - 2 NOT A SPLICE POINT. INDICATES ENTRY INTO WIRING HARNESS.
 - 1. SPLICES ARE THEORETICAL AND MAY DIFFER IN THE HARNESS.

FIRST USED	05 G37B
TITLE	DO NOT SCALE DRAWING
	WIRING DIAGRAM-BODY, 12V
SHEET 5	PART NO 150757

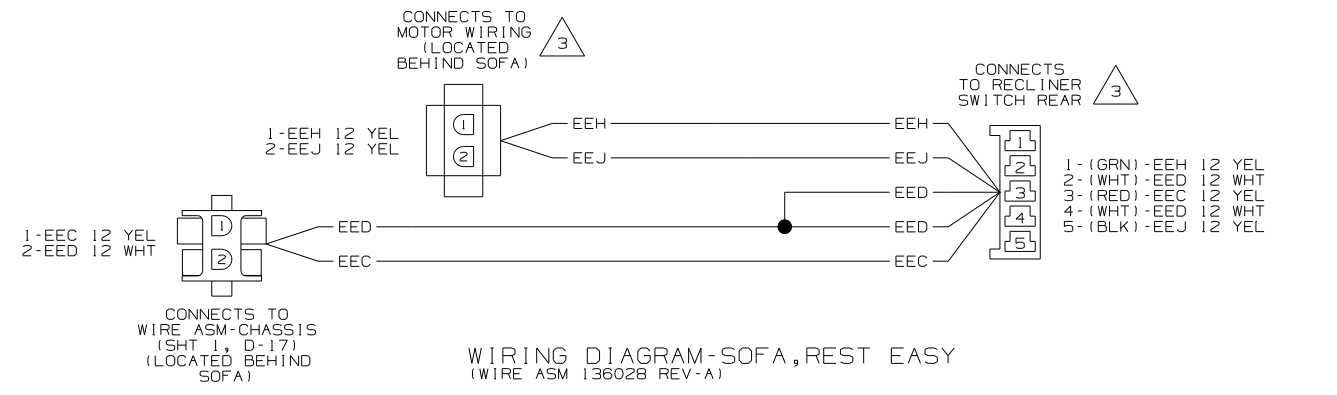
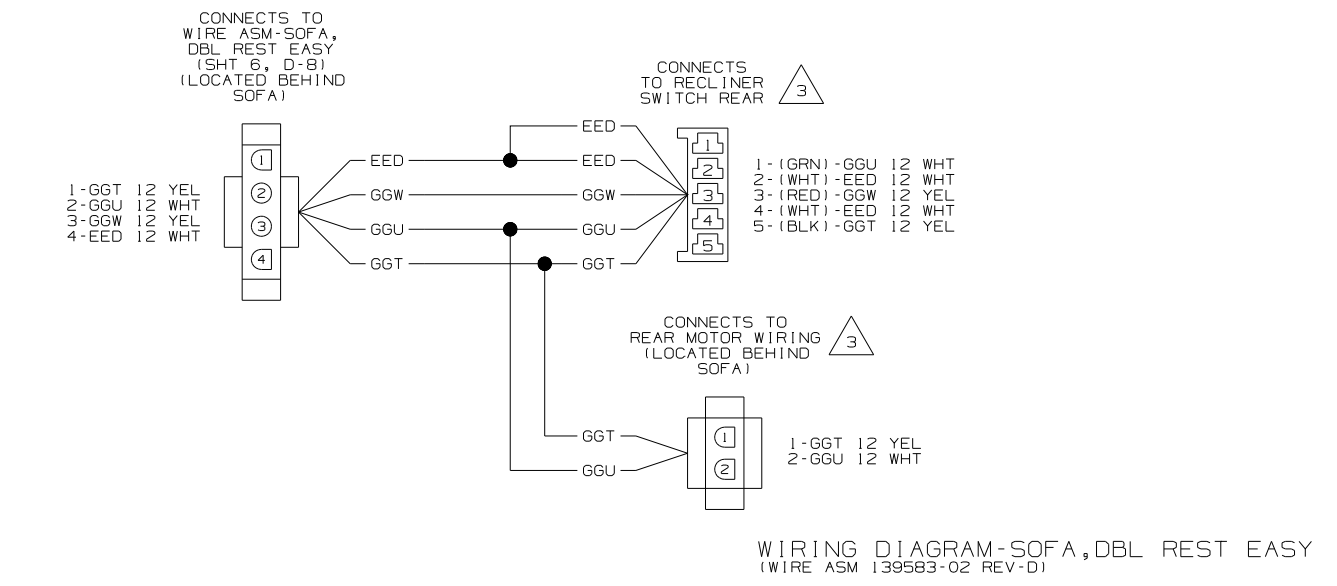
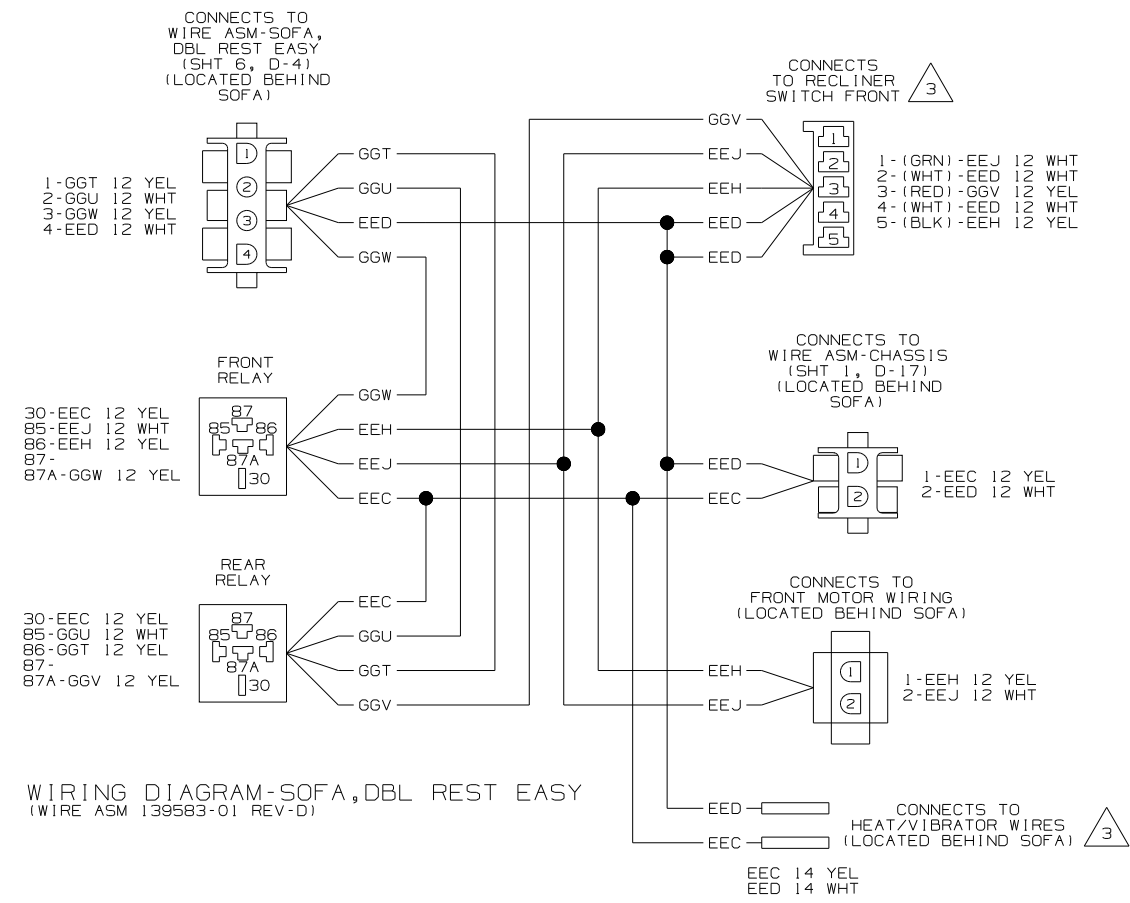

- NOTES:
- 5 SEE WIRING DIAGRAM-AUTO FOR ADDITIONAL INFORMATION.
 - 4 SEE MANUFACTURERS DIAGRAM FOR ADDITIONAL INFORMATION.
 - 3 GROUNDS ARE SHOWN AS A SINGLE LINE FOR EASE IN TRACING. EACH GROUND CIRCUIT IS SEPERATE IN THE HARNESS.
 - 2 NOT A SPLICE POINT. INDICATES ENTRY INTO WIRING HARNESS.
 - 1. SPLICES ARE THEORETICAL AND MAY DIFFER IN THE HARNESS.

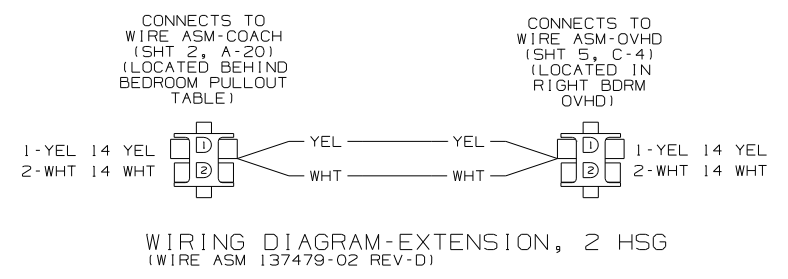
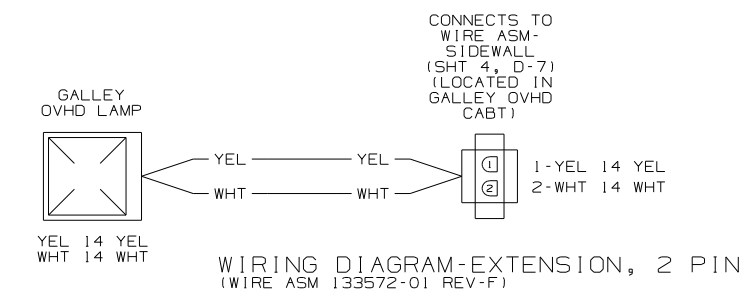
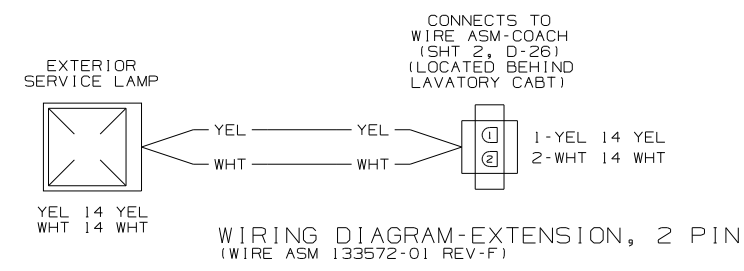

FIRST USED	05 G37B
TITLE	DO NOT SCALE DRAWING
	WIRING DIAGRAM-BODY, 12V
SHEET 6	PART NO 150757