



**DANGER**

**Danger of electrical shock, burns or death.** Always remove all power sources before attempting any repair, service or diagnostic work. Power can be present from shore power, generator, inverter or battery. All power sources must be disabled and secured before performing any service.



**CAUTION**

If you lack the skills, tools or equipment to perform diagnostic or repair work leave such work to an authorized Winnebago Industries dealer or other qualified shop.

SLIDEOUT SWITCH (TOP OF WARDROBE CABT.)



- 1-DR 16 YEL
- 2-DU 16 YEL
- 3-ER 16 YEL
- 4-
- 5-
- 6-
- 7-
- 8-

ER  
DU  
DR

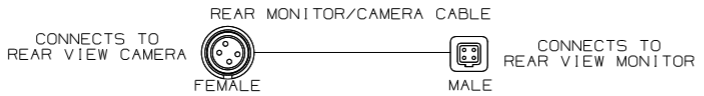

ER  
DU  
DR

GRND

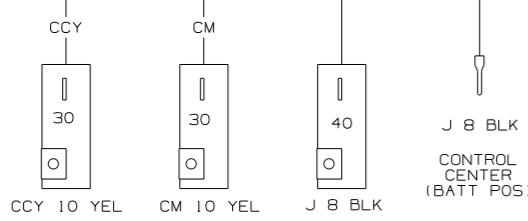

PART OF CHASSIS ELECTRICAL BOX (SHEET 1, D3-4)

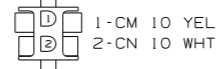

INVERTER 4

CP 12 WHT

INVERTER GROUND

WIRING DIAGRAM-CHASSIS, FORD (WIRE ASM 148361 REV-G)

CHASSIS ELECTRICAL BOX

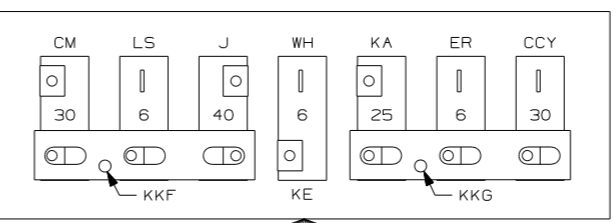

- CM 10 YEL
- LS 16 YEL
- J 8 BLK
- WH 16 YEL
- KA 12 YEL
- ER 16 YEL
- CCY 10 YEL
- KKF 6 BLK
- KE 14 YEL
- KKG 6 BLK

J CCY CM ER WH KE LS KA KKG KKF

SEE SHEET 1, ZONE A-7

IHS ER WH KE LS KA LR LH LG LJ FM

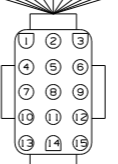

- 1-
- 2-
- 3-ER 16 YEL
- 4-
- 5-LG 16 YEL
- 6-FM 14 WHT
- 7-LR 14 YEL
- 8-IHS 16 YEL
- 9-WH 16 YEL
- 10-KE 14 YEL
- 11-LH 16 YEL
- 12-
- 13-LJ 16 YEL
- 14-LS 16 YEL
- 15-KA 12 YEL

CONNECTS TO WIRE ASM-CHASSIS (SHT 1, A-21) (LOCATED IN CHASSIS BREAKER PANEL)

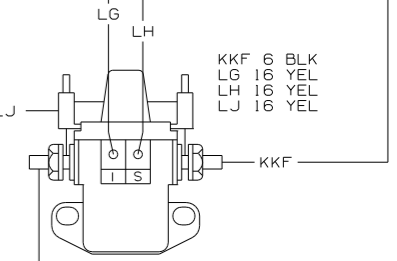

- KKF 6 BLK
- LG 16 YEL
- LH 16 YEL
- LJ 16 YEL

BATTERY DISCONNECT RELAY

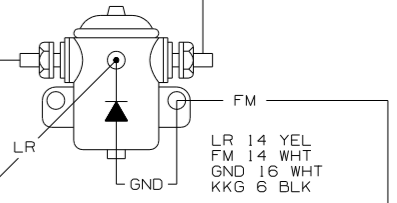

- LR 14 YEL
- FM 14 WHT
- GND 16 WHT
- KKG 6 BLK

BATTERY MODE SOLENOID

WIRING DIAGRAM-ELECTRICAL BOX (WIRE ASM 124125-04 REV-L)



DFTR	ORIG. DATE
CHNR	ALL DIMENSIONS ARE IN MILLIMETERS
P.E.	
M.E.	FIRST USED
DSNR	05 723D
UNSPECIFIED TOLERANCES ARE:	MATERIAL:
HOLE DIM (X)	:
ONE-PLACE (X.X)	:
TWO-PLACE (X.XX)	:
ANGLE	:
THIRD ANGLE PROJECTION	

DO NOT SCALE DRAWING

TITLE: WIRING DIAGRAM-BODY, 12V

SHEET 1 of 5 PART NO 148238

CONNECTS TO RADIO SWITCH

- 1-LD 14 YEL
- 2-WN 16 YEL
- 3-JF 14 YEL
- 4-MK 14 YEL
- 5-GT 16 YEL
- 6-JF 14 YEL
- 7-
- 8-

CONNECTS TO DASH RADIO ASM

- 1-MK 14 YEL
- 2-LD 14 YEL
- 3-GT 16 YEL
- 4-WN 16 YEL

CONNECTS TO WIRE ASM-RIGHT (SHT 3, D-4) (UNDER SOFA)

- 1-JM 14 WHT
- 2-XH 16 YEL
- 3-LA 16 YEL
- 4-JB 14 YEL
- 5-AB 16 WHT
- 6-LC 16 WHT
- 7-WB 16 YEL
- 8-UK 16 WHT
- 9-KR 16 WHT
- 10-
- 11-LB 16 WHT
- 12-KX 16 YEL
- 13-JF 14 YEL
- 14-NF 14 WHT
- 15-PJ 14 YEL

CONNECTS TO FORD WIRING (LOCATED BEHIND DRIVER DOOR)

- DK BLU/WHT-LA 16 YEL
- GRN/WHT-LC 16 WHT
- RED/WHT-KX 16 YEL
- YEL/RED-LB 16 WHT

CONNECTS TO WIRE ASM-LEFT (SHT 2, C-8) (IN WARDROBE BY LOAD CENTER)

- 1-JS 12 YEL
- 2-LP 16 YEL
- 3-LL 16 WHT
- 4-LM 16 WHT
- 5-LN 16 WHT
- 6-JD 14 YEL
- 7-GL 16 WHT
- 8-JX 14 WHT
- 9-WB 14 YEL
- 10-XH 16 YEL
- 11-JM 14 WHT
- 12-WN 16 YEL

CONNECTS TO GENERATOR 4

- A-LN 16 WHT
- B-LM 16 WHT
- C-LL 16 WHT
- D-
- E-
- F-LP 16 YEL
- G-
- H-

CONNECTS TO WIRE ASM-SIDEWALL (SHT 5, C-4) (UNDER FRONT DINETTE SEAT)

- 1-JD 14 YEL
- 2-ND 14 WHT

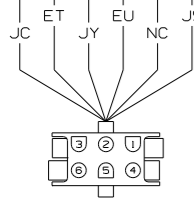
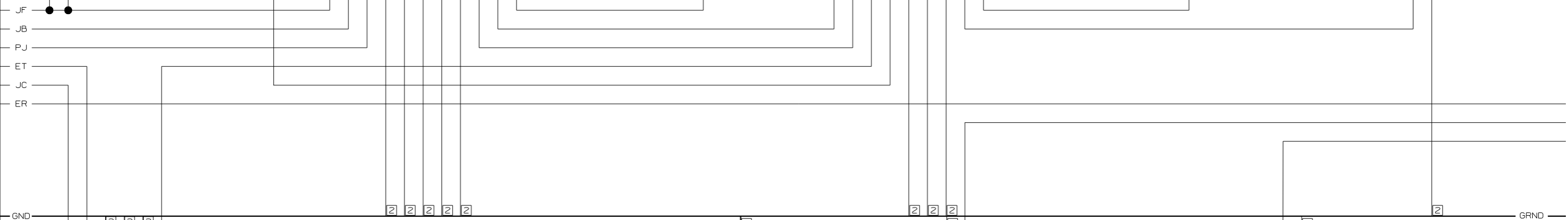

- 1-JC 14 YEL
- 2-NC 14 WHT
- 3-ET 16 YEL
- 4-EU 16 WHT
- 5-JS 12 YEL
- 6-JY 12 WHT

CONNECTS TO WIRE ASM-RIGHT (SHT 3, A-3) (LOCATED BELOW REFRIGERATOR)

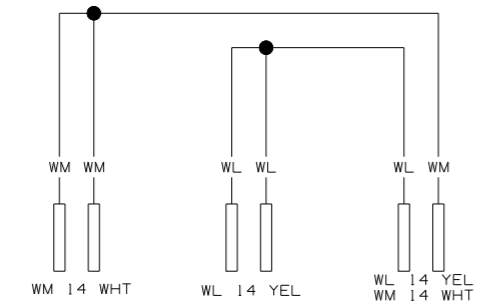

WM 14 WHT  
WL 14 YEL  
WL 14 YEL  
WM 14 WHT

FORD HOUSING CONNECTS TO RED/ORG  
FORD HOUSING CONNECTS TO PK/BLK  
ENTRANCE DOOR POWER DOOR LOCKS

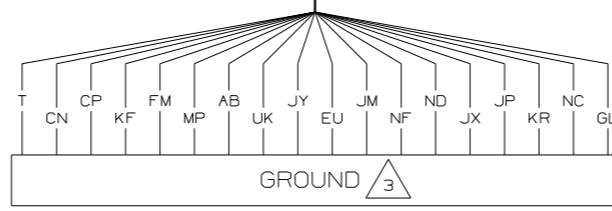

- T 10 WHT
- CN 12 WHT
- GL 16 WHT
- CP 12 WHT
- KF 16 WHT
- FM 14 WHT
- MP 16 WHT
- AB 16 WHT
- UK 14 WHT
- JY 12 WHT
- EU 16 WHT
- NF 14 WHT
- CP 12 WHT
- ND 14 WHT
- JX 14 WHT
- JP 14 WHT
- KR 14 WHT
- NC 12 WHT
- GL 16 WHT
- UK 16 WHT
- JY 12 WHT
- ND 14 WHT
- JX 14 WHT
- JP 14 WHT
- KR 14 WHT
- NC 12 WHT
- GL 16 WHT
- UK 16 WHT
- JY 12 WHT
- ND 14 WHT
- JX 14 WHT
- JP 14 WHT
- KR 14 WHT
- NC 12 WHT
- GL 16 WHT

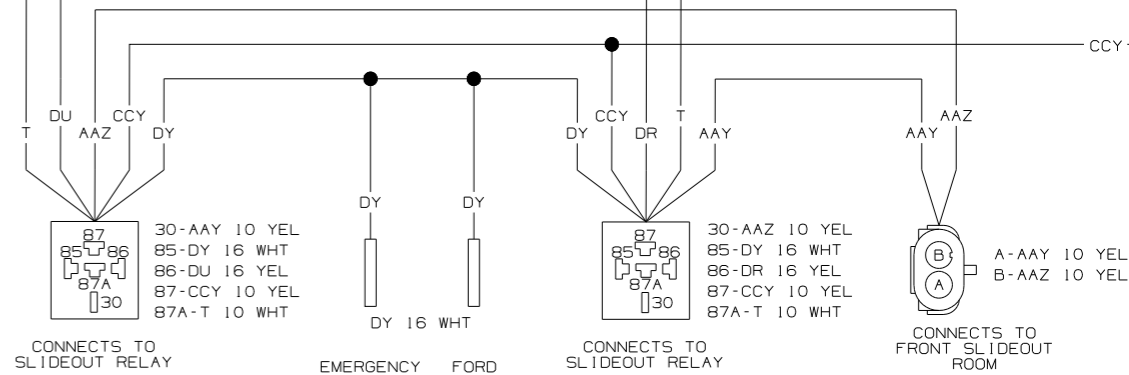

- 87 30-AAZ 10 YEL
- 85 85-DY 16 WHT
- 86 86-DU 16 YEL
- 87 87-CCY 10 YEL
- 87A 87A-T 10 WHT

- 87 30-AAZ 10 YEL
- 85 85-DY 16 WHT
- 86 86-DR 16 YEL
- 87 87-CCY 10 YEL
- 87A 87A-T 10 WHT

- A-AAZ 10 YEL
- B-AAZ 10 YEL

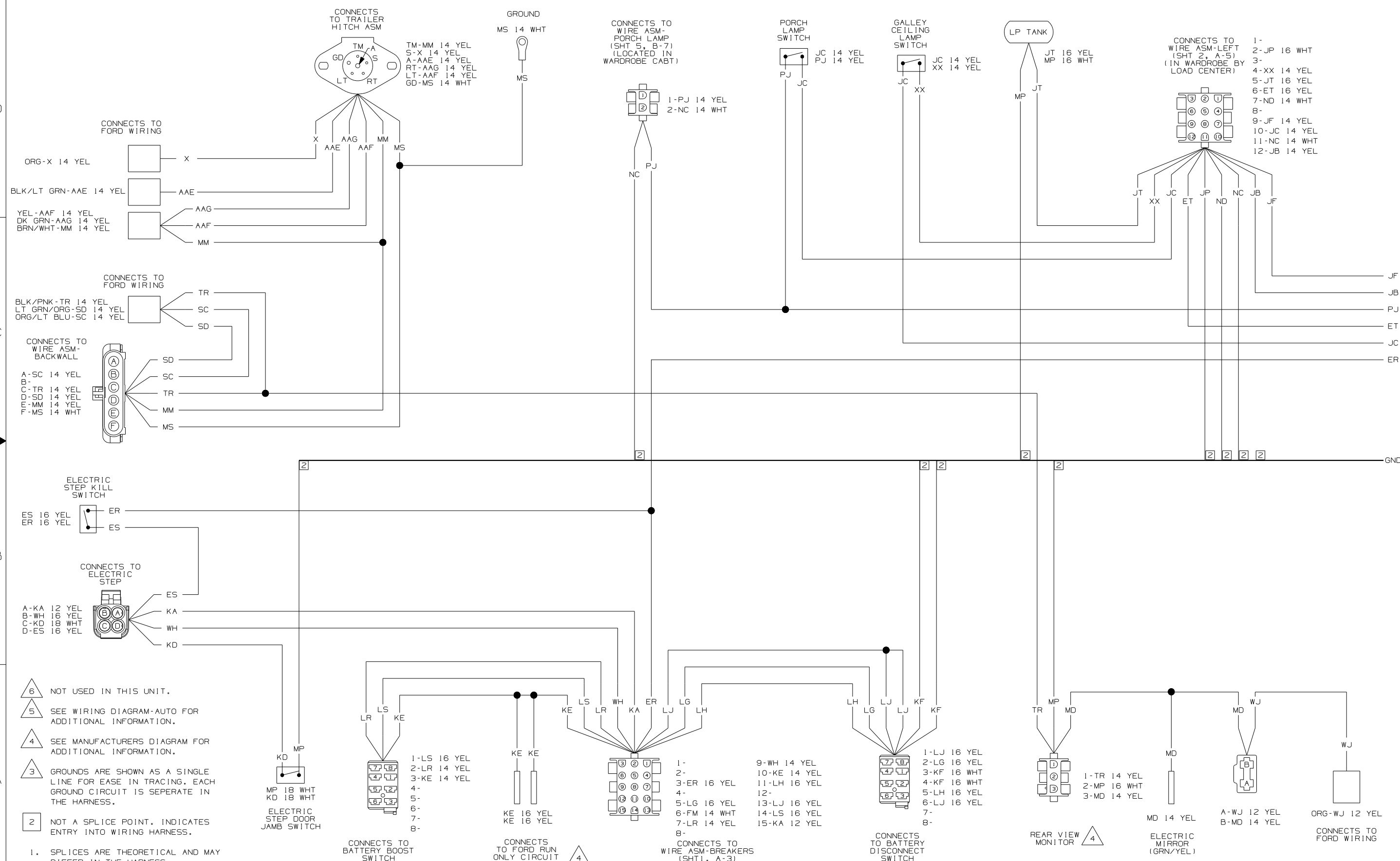

- NOTES:
- 1. SPLICES ARE THEORETICAL AND MAY DIFFER IN THE HARNESS.
  - 2. NOT A SPLICE POINT. INDICATES ENTRY INTO WIRING HARNESS.
  - 3. GROUNDS ARE SHOWN AS A SINGLE LINE FOR EASE IN TRACING. EACH GROUND CIRCUIT IS SEPERATE IN THE HARNESS.
  - 4. SEE MANUFACTURERS DIAGRAM FOR ADDITIONAL INFORMATION.
  - 5. SEE WIRING DIAGRAM-AUTO FOR ADDITIONAL INFORMATION.
  - 6. NOT USED IN THIS UNIT.

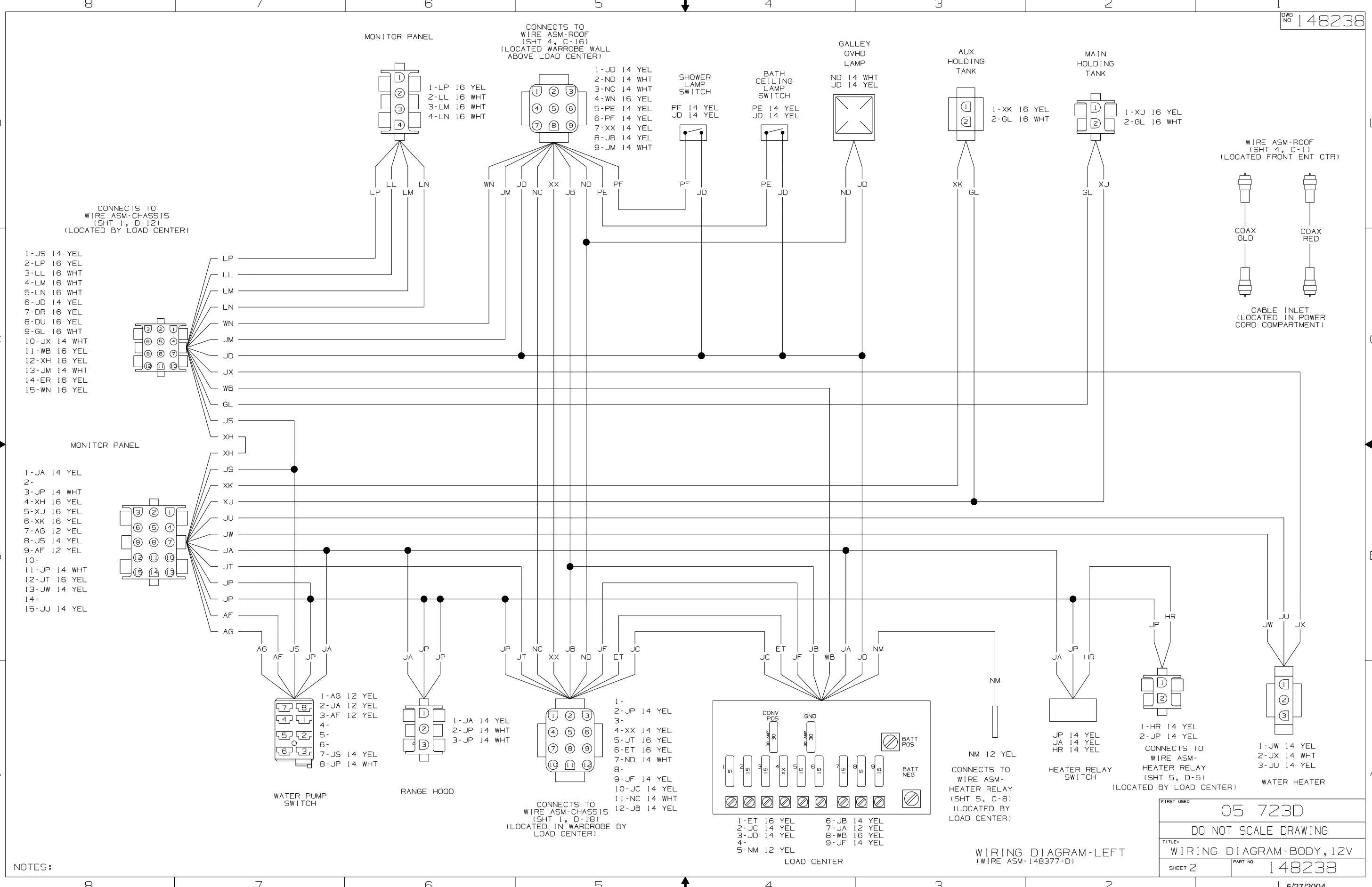

NOTES:

WIRING DIAGRAM-LEFT  
(WIRE ASM-148377-D)

FIRST USED	05 723D
DO NOT SCALE DRAWING	
TITLE	WIRING DIAGRAM-BODY, 12V
SHEET 2	PART NO 148238

CONNECTS TO WIRE ASM-EXT ENT CTR (SHT 6, C-6) (LOCATE BELOW COUCH)

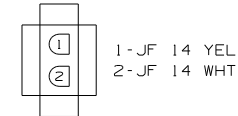

CONNECTS TO TWO-WAY RADIOS

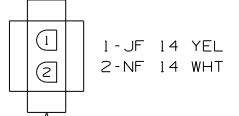

CONNECTS TO WIRE ASM-TANK, WATER

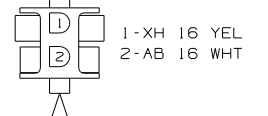

CONNECTS TO WIRE ASM-CHASSIS (SHT 2, D-14) (LOCATED BELOW SOFA)

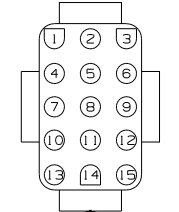

- 1-JM 14 WHT
- 2-XH 16 YEL
- 3-LA 16 YEL
- 4-JB 14 YEL
- 5-AB 16 WHT
- 6-LC 16 WHT
- 7-WB 16 YEL
- 8-UK 16 WHT
- 9-KR 16 WHT
- 10-
- 11-LB 16 WHT
- 12-KX 16 YEL
- 13-JF 14 YEL
- 14-NF 14 WHT
- 15-PJ 14 YEL

CONNECTS TO LP DETECTOR

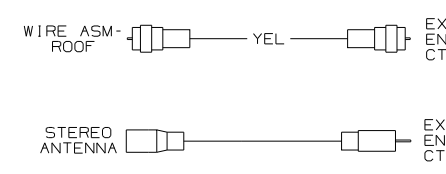
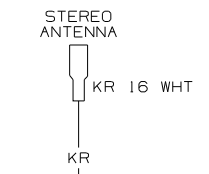
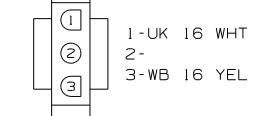

CONNECTS TO FURNACE

- 1-JM 14 WHT
- 2-JJ 14 YEL
- 3-JB 14 YEL
- 4-JH 14 YEL

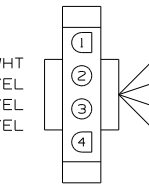

CONNECTS TO THERMOSTAT

- 1-XP 16 YEL
- 2-JH 14 YEL
- 3-JM 14 WHT
- 4-JJ 14 YEL

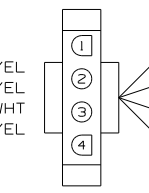

CONNECTS TO WIRE ASM-ROOF (SHT 4, D-15) (LOCATED IN SOFA OVHD CABT.)

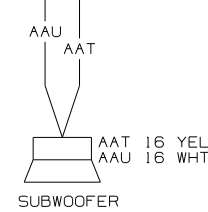
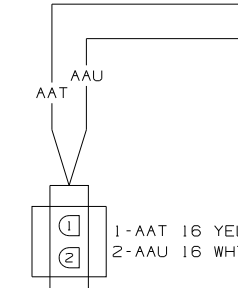

CONNECTS TO THERMOSTAT

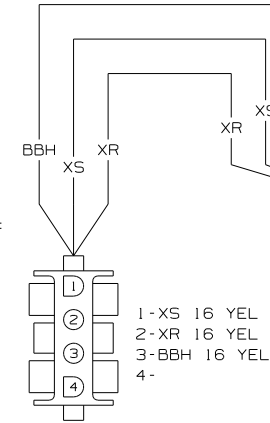

CONNECTS TO WIRE ASM-ROOF (SHT 4, B-6) (LOCATED IN SOFA OVHD CABT.)

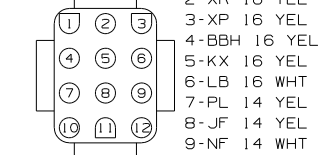

- 1-XS 16 YEL
- 2-XR 16 YEL
- 3-XP 16 YEL
- 4-BBH 16 YEL
- 5-KX 16 YEL
- 6-LB 16 WHT
- 7-PL 14 YEL
- 8-JF 14 YEL
- 9-NF 14 WHT
- 10-LA 16 YEL
- 11-LC 16 WHT
- 12-

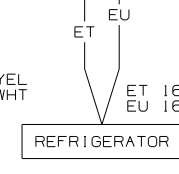
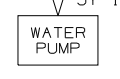
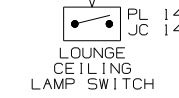

CONNECTS TO WIRE ASM-CHASSIS (SHT 2, A-16) (LOCATED BELOW REFRIGERATOR)

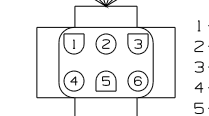

- 1-JC 14 YEL
- 2-NC 14 WHT
- 3-ET 16 YEL
- 4-EU 16 WHT
- 5-JS 12 YEL
- 6-JY 12 WHT

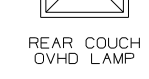

WIRING DIAGRAM-RIGHT (WIRE ASM 148376 REV-C)

FIRST USED	05 723D
DO NOT SCALE DRAWING	
TITLE:	WIRING DIAGRAM-BODY, 12V
SHEET 3	PART NO 148238

NOTES:  
2 SEE WIRING DIAGRAM-AUTO FOR ADDITIONAL INFORMATION.  
1 SEE MANUFACTURERS DIAGRAM FOR ADDITIONAL INFORMATION.

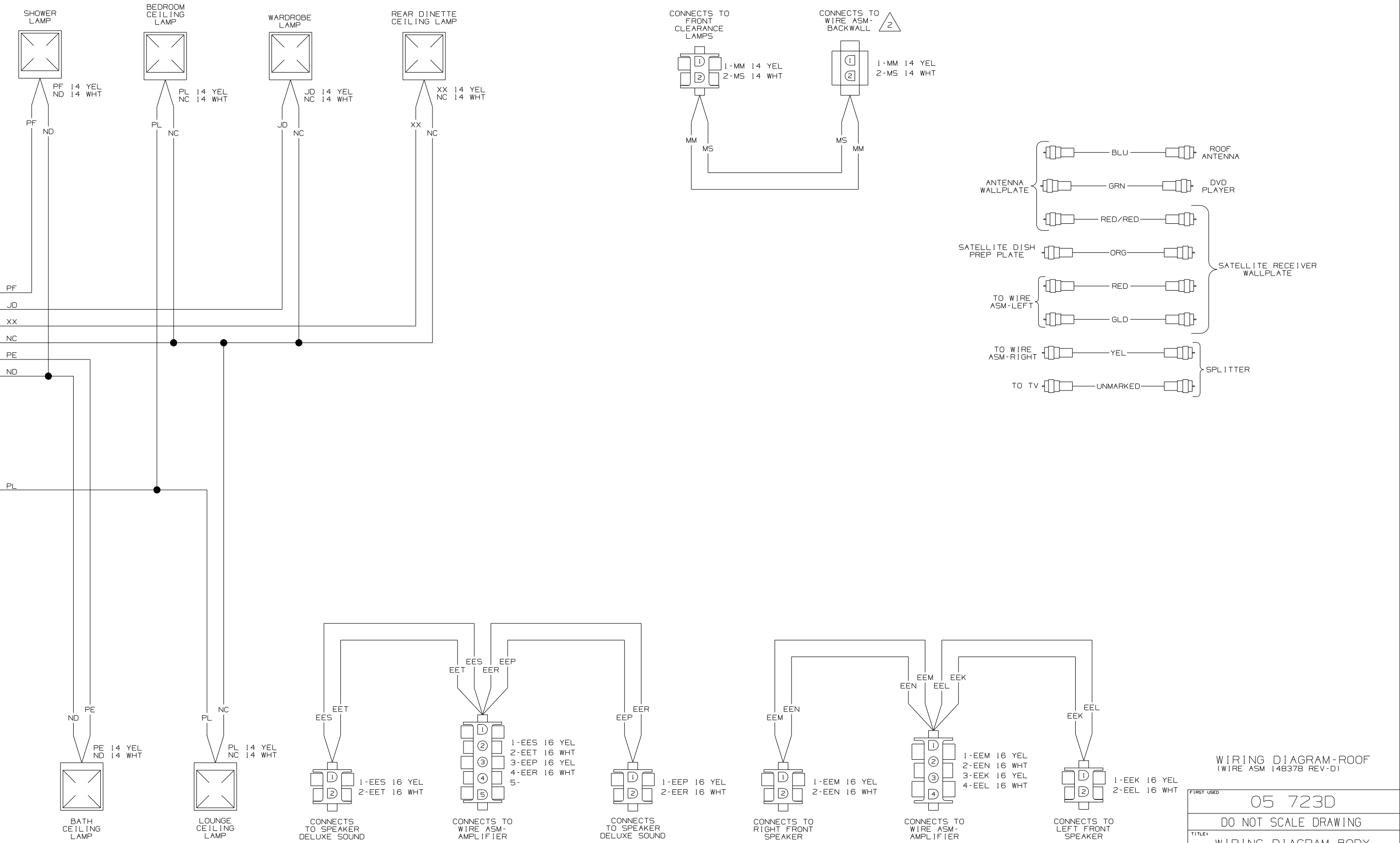

WIRING DIAGRAM-ROOF  
(WIRE ASM 149378 REV-D)

FIRST USED 05 723D

DO NOT SCALE DRAWING

TITLE: WIRING DIAGRAM-BODY

F1	SHEET 4	PART NO 148238
----	---------	----------------

CONNECTS TO WIRE ASM-RIGHT (SHT 3, X-X) (LOCATED IN SOFA OVHD CABT.)

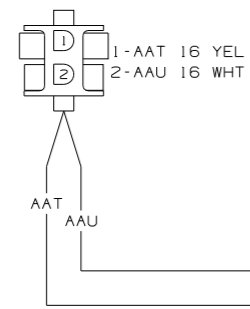

CONNECTS TO WIRE ASM-AMPLIFIER

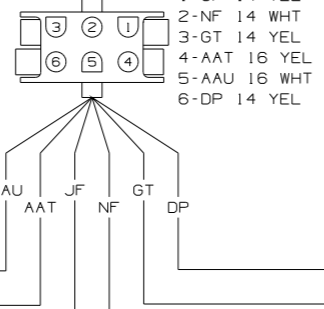

RADIO/TV POWER SWITCH

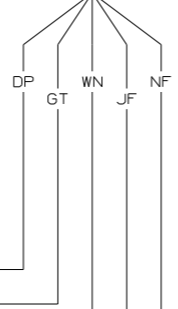

IN MOTION SATELLITE POWER SWITCH

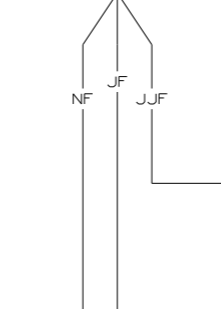

IN MOTION SATELLITE

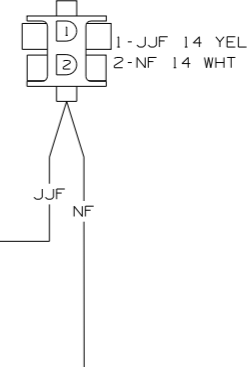

DIGITAL SATELLITE ELEVATION SENSOR

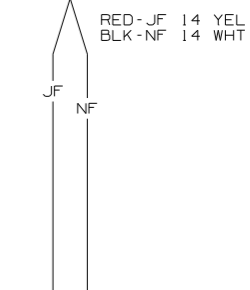

CONNECTS TO WIRE ASM-LEFT (SHT 2, D-5) (LOCATED IN WARDROBE WALL ABOVE LOAD CENTER)

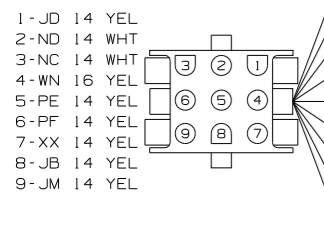

CONNECTS TO WIRE ASM-RIGHT (SHT 3, A-6) (LOCATED IN SOFA OVHD CABT.)

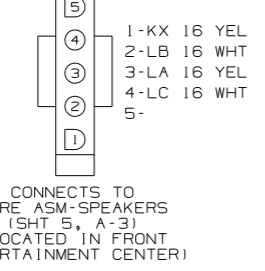
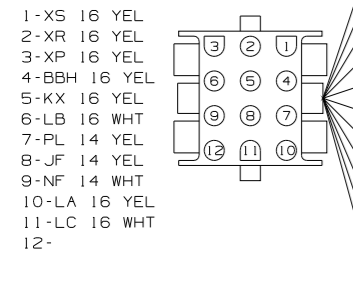

ROOF A/C

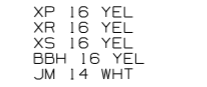

ANTENNA WALLPLATE



12V RCP DVD PLAYER



DVD PLAYER SWITCH



BATH VENT



GALLEY VENT



NOTES:  
 2 SEE WIRING DIAGRAM-AUTO FOR ADDITIONAL INFORMATION.  
 1 SEE MANUFACTURERS DIAGRAM FOR ADDITIONAL INFORMATION.



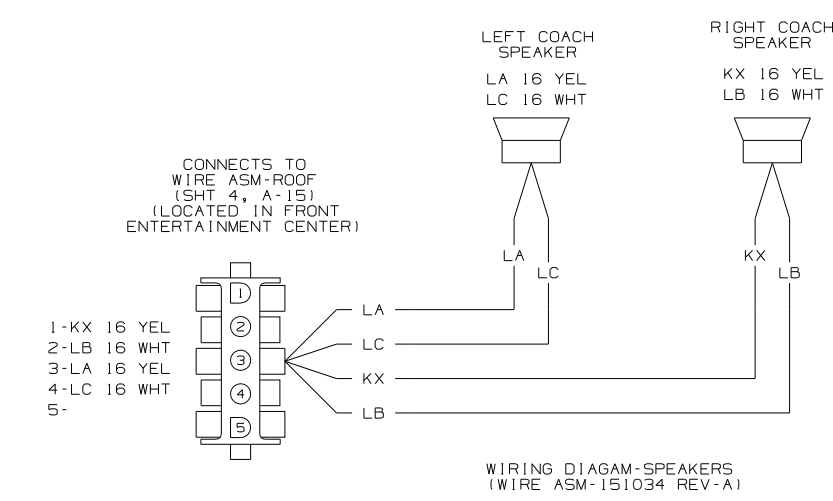
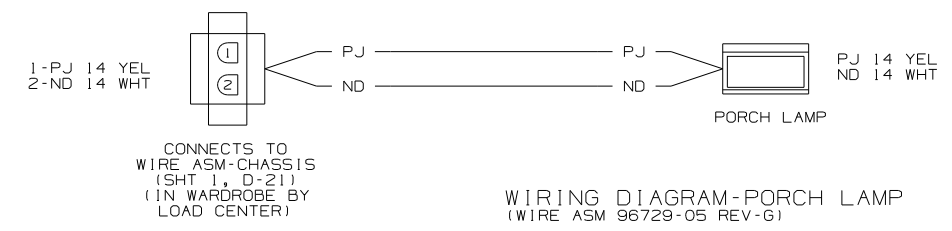
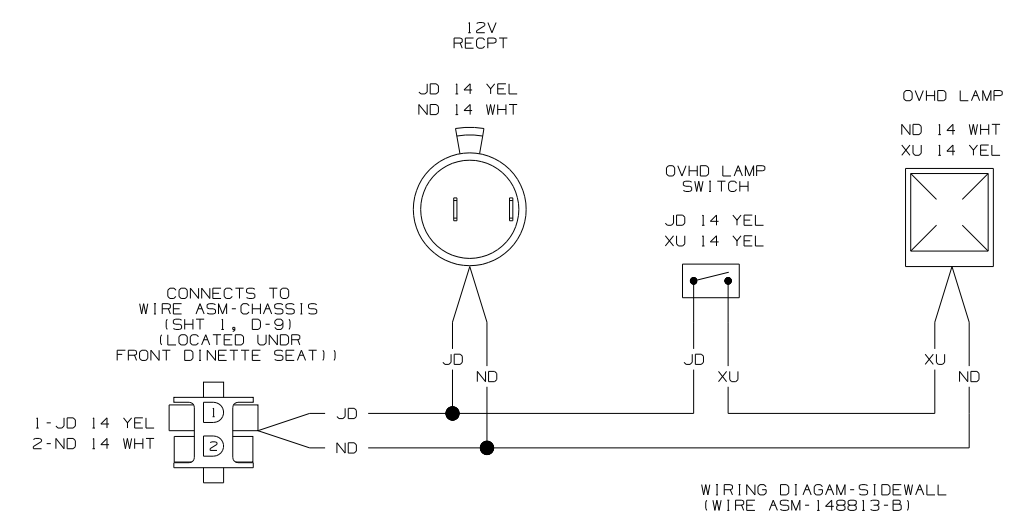
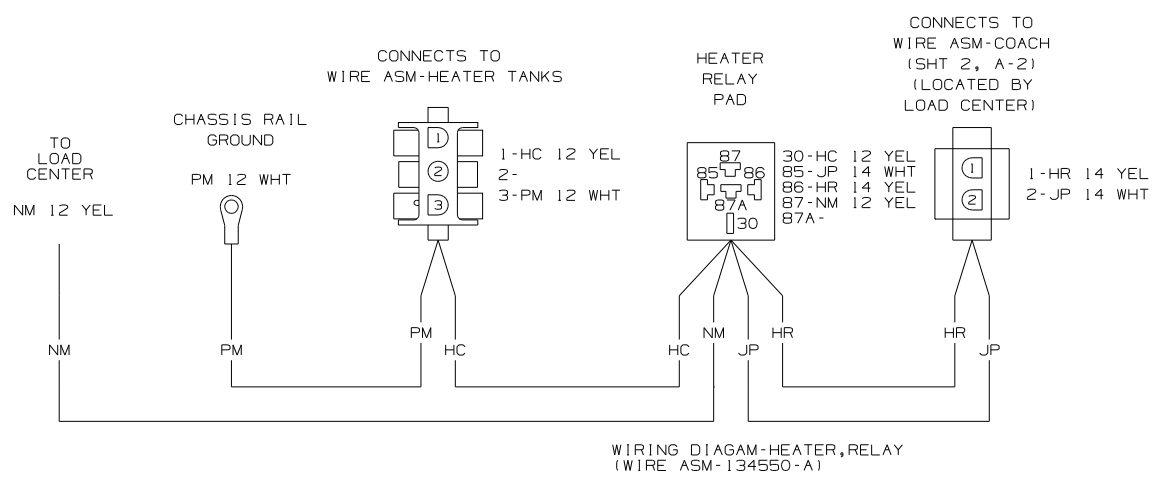

NOTES:

FIRST USED	05 723D
TITLE	DO NOT SCALE DRAWING
	WIRING DIAGRAM-BODY,12
SHEET 5	PART NO 148238